

**PECOL, 35 anos fixados em si!**



PT



GB



FR



ES





---

## **CATÁLOGO GERAL**

*/General Catalogue / Catalogue Général  
/ Catálogo General*

004	<b>APRESENTAÇÃO</b> <i>Presentation / Présentation / Presentación</i>
019	<b>ÍNDICE</b> <i>Index / Index / Índice</i>
031	<b>SEGMENTOS DE ATIVIDADE</b> <i>Market segment / Segments d'activité / Segmentos de Actividad</i>
057	<b>TABELA PCL'S E DIN'S</b> <i>PCL and DIN table / Tableau de PCL's et DIN's / Tabla de PCL's y DIN's</i>
061	<b>PARAFUSOS ROSCA MÉTRICA</b> <i>Metric thread screw / Vis filet métrique / Tornillos rosca métrica</i>
073	<b>PARAFUSOS AUTO-PERFORANTES E AUTO-ROSCANTES</b> <i>Drill and Tapping Screws / Vis autoperceuse et Vis à Tôle / Tornillo autotaladrar y Autoroscante</i>
089	<b>PARAFUSOS PARA MADEIRA</b> <i>Wood Screws / Vis pour Bois / Tornillos para Madera</i>
099	<b>REBITES</b> <i>Blind rivets / Rivets / Remaches</i>
111	<b>BUCHAS METÁLICAS</b> <i>Metal anchors / Chevilles métalliques / Anclajes Metálicos</i>
135	<b>BUCHAS QUÍMICAS</b> <i>Metal anchors / Chevilles métalliques / Anclajes Químicos</i>
143	<b>BUCHAS PLÁSTICAS</b> <i>Metal anchors / Chevilles métalliques / Anclajes Plásticos</i>
155	<b>ABRAÇADEIRAS POLIAMIDA</b> <i>Cable Ties / Colliers en Polyamide / Abrazaderas Poliamida</i>
161	<b>ABRAÇADEIRAS METÁLICAS</b> <i>Metallic Clamps / Colliers Métalliques / Abrazaderas Metálicas</i>
169	<b>INSTALADORES</b> <i>Framing Systems / Supportage / Soportacion</i>
173	<b>FITAS ADESIVAS</b> <i>Tapes / Ruban Adhésif / Cintas Adhesivas</i>
181	<b>VEDAÇÃO E COLAGEM</b> <i>Sealing and Bonding / Étanche et Collage / Sellado y Pegado</i>
243	<b>SPRAYS</b> <i>Sprays / Sprays / Sprays</i>
263	<b>CORTE</b> <i>Cut / Coupe / Corte</i>
285	<b>DISCOS ABRASIVOS E POLIMENTO</b> <i>Abrasive Discs and Polishing / Disques Abrasifs et Polissage / Discos Abrasivos y Pulidos</i>
299	<b>DISCOS DIAMANTADOS</b> <i>Diamond Wheels / Disques Diamant / Discos Diamantados</i>
307	<b>FERRAMENTA ELÉTRICA</b> <i>Power Tools / Outillage Électrique / Herramienta Eléctrica</i>
327	<b>SOLDADURA</b> <i>Welding / Soudure / Soldadura</i>
339	<b>PROTEÇÃO E SEGURANÇA</b> <i>Safety and Security / Protection et Sécurité / Protección y Seguridad</i>
349	<b>FERRAMENTA MANUAL</b> <i>Hand Tools / Outillage Manuel / Herramienta Manual</i>
381	<b>MANUTENÇÃO E ORGANIZAÇÃO</b> <i>Maintenance and Organization / Maintenance et Organisation / Mantenimiento y Organización</i>
391	<b>FERRAGENS</b> <i>Furniture Hardware / Quincaillerie du Meuble / Herrajes</i>
405	<b>GESO CARTONADO</b> <i>Drywall / Plaques de Plâtre / Yeso Laminado</i>
415	<b>CONDIÇÕES GERAIS DE VENDA E PRESTAÇÃO DE SERVIÇOS</b>

# PECOL GROUP INDUSTRIAL



O Grupo, no seu conjunto, conta com cerca de 600 colaboradores, tem a sua sede instalada na cidade de Águeda – Portugal numa área aproximada de 150.000 m<sup>2</sup>.

*The Pecol Group employs approximately 600 workers and the headquarters in Águeda has facilities with an area of 150.000 m<sup>2</sup>.*

*Le groupe Pecol est constitué par 600 collaborateurs et le siège social est basé à Águeda – Portugal dans une zone de 150.000 m<sup>2</sup>.*

*El grupo en su conjunto, tiene cerca de 600 empleados, y su sede está ubicada en la ciudad de Aveiro - Portugal, con una superficie aproximada de 150.000 m<sup>2</sup>.*

## PECOL GROUP INDUSTRIAL

O Grupo Pecol é constituído por diversas plataformas de negócio implantadas em Portugal, Espanha, Itália, Angola, Polónia e Marrocos.

*/ Pecol Group has complementary business platforms based in Portugal, Spain, Italy, Angola, Poland and Morocco.*

*/ Le Groupe Pecol est composé par plusieurs plates-formes commerciales notamment au Portugal, Espagne, Italie, Angola, Pologne et Maroc.*

*/ El Grupo Pecol se compone de varias plataformas de negocio desplegadas en Portugal, España, Italia, Angola, Polonia y Marruecos.*



## FILIAIS / Own Branches / Succursale / Filiales

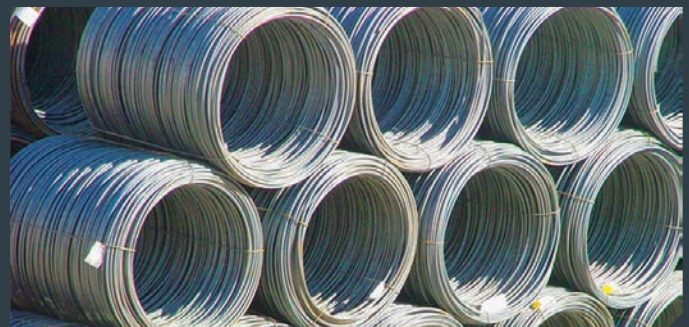

# GRUPO PECOL

**Pecol** é um grupo Português de origem industrial, fundado em Águeda, em 1983. Atualmente, ocupa um lugar de relevo a nível europeu, disponibilizando uma oferta global de produtos e serviços na área da fixação e montagem, para todo o tipo de indústrias, em conformidade com os mais rigorosos critérios de qualidade.

O Grupo Pecol é constituído por diversas plataformas de negócio implantadas em **Portugal, Espanha, Itália, Angola, Polónia e Marrocos.**

A Pecol – Sistemas de Fixação está integrada neste dinâmico, sólido e experiente grupo empresarial. O seu desenvolvimento sustentado assenta numa rigorosa gestão e política de qualidade, sendo certificada no âmbito da comercialização e distribuição de parafusaria (Norma ISO 9001/2008), aliada a uma forte aposta em investigação e desenvolvimento de novos produtos. A estes junta uma robusta dinâmica comercial, baseada na proximidade com os clientes, na utilização de modernas tecnologias e na competência dos seus profissionais, recrutados através de um rigoroso processo de seleção e alvo de formação contínua.

Nas suas instalações em Águeda, o grupo Pecol possui um armazém com capacidade para guardar em stock 45.000 paletes, uma fábrica para tratamentos térmicos (**RETSACOAT**), uma unidade de fabrico de ferramentas e peças especiais em metal duro (**SERMOCOL**) e a maior unidade da Península Ibérica de fabricação de peças por estampagem a frio (**PECOL AUTOMOTIVE**).



## PECOL GROUP

*Pecol is a Portuguese industrial group that was founded in the city of Águeda (Portugal) in 1983. Currently Pecol holds a relevant position in Europe, providing a global range of products and services in the areas of fixing and assembly systems, for all kinds of industry and trade, in compliance with the most strict quality criteria.*

*Pecol Group has complementary business platforms based in Portugal, Spain, Italy, Angola, Poland and Morocco.*

*Pecol – Sistemas de Fixação SA, is integrated into a dynamic, solid and experienced corporate group. Its sustained development is based on a rigorous management and quality policy, being certified with ISO 9001/2008 standard, as well as a strong emphasis on research and development of new products. Besides this, Pecol complements its business strategy with a solid and dynamic commercial approach, based on the proximity with its clients, using the most modern technologies and optimizing the skills of its professionals, which are recruited by a rigorous selection process and supported with a continuous training plan.*

*In its Águeda facilities, Pecol has a warehouse able to store 45.000 palletes, a surface metal coating and treatment plant (RETSACOAT), a plant specialized on manufacturing tools and technical parts in hard metal (SERMOCOL) and the largest unit for manufacturing parts by cold stamping (PECOL AUTOMOTIVE) in Iberia.*

## GRUPE PECOL

*Pecol est un groupe portugais d'origine industrielle, fondée en Águeda, en 1983. Il occupe actuellement une place importante au niveau européen, en fournissant une gamme complète de produits et services dans le domaine de la fixation et de montage pour tous les types d'industries, en conformité avec les critères les plus stricts de qualité.*

*Le Groupe Pecol est composé par plusieurs plates-formes commerciales notamment au Portugal, Espagne, Italie, Angola, Pologne et en Maroc. Pecol – Systèmes de fixation fait partie de ce groupe d'affaires reconnue par sa dynamique et expérience dans le secteur. Son développement durable est basée dans une gestion rigoureuse et d'une stricte politique de qualité. Pecol combine la recherche et développement de nouveaux produits aux certifications nécessaires à l'activité (ISO 9001/2008).*

*Notre dynamique commerciale, basée dans la proximité avec les clients, utilisation des nouvelles technologies et l'expérience de nos professionnels, recrutés par le biais d'un processus de sélection rigoureux et la formation cible vient compléter les caractéristiques de notre groupe.*

*Dans ses installations à Águeda, le groupe Pecol dispose d'un entrepôt capable de stocker 45.000 palettes, une usine pour les traitements thermiques (RETSACOAT), une unité de fabrication d'outils et de pièces spéciales en métal dur (SERMOCOL) et la plus grande unité de fabrication de pièces frappées à froid dans la péninsule ibérique (PECOL AUTOMOTIVE).*

## GRUPO PECOL

*Pecol es un grupo portugués de origen industrial, fundado en Águeda, en 1983. En la actualidad ocupa un lugar relevante en el ámbito europeo, proporcionando una gama completa de productos y servicios de fijación y montaje para todo tipo de industrias, de acuerdo con los más estrictos criterios de calidad.*

*El Grupo Pecol se compone de varias plataformas de negocio desplegadas en Portugal, España, Italia, Angola, Polonia y Marruecos. Pecol - Sistemas de fijación está integrado en este grupo empresarial dinámico, sólido y con experiencia. Su desarrollo está basado en una gestión rigurosa de la política de calidad, teniendo la certificación ISO 9001/2008 para la comercialización y distribución de los tornillos, combinado con un fuerte enfoque en la investigación y desarrollo de nuevos productos.*

*A esto se une un desempeño comercial robusto, basado en la proximidad a los clientes, el uso de tecnologías modernas y la experiencia de sus profesionales, reclutados a través de un riguroso proceso de selección y formación continua.*

*En sus instalaciones de Águeda, el grupo Pecol tiene un almacén con una capacidad para 45.000 palets en stock, una planta para el tratamiento térmico y superficial (RETSACOAT), una unidad de fabricación de herramientas y piezas especiales en metal duro (SERMOCOL) y la unidad más grande de la Península Ibérica para la fabricación de piezas de estampación en frío (PECOL AUTOMOTIVE).*

Sede / headquarters / Siège social / Sede



# PECOL<sup>®</sup> 35

Sistemas de Fixação

1983-2018

EMPRESA CERTIFICADA  
 APCER  
 CERTIFICAÇÃO Nº 99/02EP-976  
 SISTEMA PORTUGUESA  
 DA QUALIDADE  
 Nº ENISO 9002

**Certificação ISO 9002:1995**  
 ISO 9002:1995 Accreditation  
 / Certification ISO 9002:1995  
 / Certificación ISO 9002:1995



**Fundação por Eduardo Coelho**  
 Foundation by Eduardo Coelho  
 / Fondée par M. Eduardo COELHO  
 / Fundación por Eduardo Coelho



**Paulo Coelho assume a presidência da Pecol**  
 Paulo Coelho takes over the presidency of Pecol / M. Paulo COELHO prend la présidence de Pecol / Paulo Coelho assume la presidencia de la Pecol



**Aquisição da HERZA**  
 Acquisition of HERZA  
 / Acquisition de HERZA  
 / Adquisición de HERZA



**Início Diversificação da Gama**  
 Beginning of Diversification of the Range  
 / Début de la Diversification de la Gamme  
 / Inicio de la Diversificación de la Gama



**Construção da ETAR**  
 Construction of ETAR  
 / Construction de la Station d'Épuration / Construcción de ETAR



**Abertura Filial Alverca**  
 Opening of Alverca Subsidiary  
 / Ouverture de la Filiale d'Alverca  
 / Apertura de Sucursal de Alverca



**Campanha nos Estádios de Futebol**  
 Football Stadiums Campaign  
 / Campagne dans les stades de Football  
 / Campaña en los Estadios de Fútbol

**PecFix<sup>®</sup>**

**Criação da Marca Pecfix**  
 Creation of the Pecfix Brand  
 / Création de la Marque Pecfix  
 / Creación de la marca Pecfix



**Abertura da 1ª Filial em Lisboa (Belém)**  
 Opening of the 1st Subsidiary in Lisbon (Belém) / Ouverture de la 1ère Filiale à Lisbonne (Belém) / Apertura de la primera sucursal en Lisboa (Belém)



**Aquisição da Parinox**  
 Acquisition of Parinox  
 / Acquisition de Parinox  
 / Adquisición de Parinox



**1ª Máquina Zincagem Industrial**  
 1st Machine of Industrial Zinc Coating  
 / 1ere Machine Zincage Industriel  
 / 1ª Máquina de Zincado Industrial



**Criação Dep. de Qualidade**  
 Creation of Quality Department  
 / Création du Département de Qualité  
 / Creación Dep. De Calidad



**1ª Máquina de Estampagem a frio**  
 1st Cold Stamping Machine  
 / 1ere Machine d'Estampage à froid  
 / 1ª Máquina de Estampación en frío



**Aquisição do 1º Forno**  
 Acquisition of the 1st Oven  
 / Acquisition du 1er Four  
 / Adquisición del 1º Horno



**Ampliação do Armazém**  
 Warehouse Extension  
 / Agrandissement de l'Entrepôt  
 / Ampliación del almacén



**Investimento na Equipa LA Pecol. Vencedora da Volta a Portugal**  
 Investment in the LA Pecol Team. Winner of "Volta a Portugal" / Investissement dans l'Équipe LA Pecol. Equipe gagnante du Tour de Portugal / Inversión en el equipo LA Pecol. Ganador de la "Voiutta a Portugal"



**Instalação da Linha de Dacromet**  
 Dacromet Line Installation  
 / Installation de la Ligne de Dacromet  
 / Instalación de la Línea de Dacromet



**Separação das áreas de Negócio da Pecol**  
 Separation of the Business Areas of Pecol / Séparation des domaines d'Activité de Pecol / Separación de las áreas de Negocio de la Pecol



**Certificação ISO 9001:2000**  
 ISO 9001:2000 Accreditation  
 / Certification ISO 9001:2000  
 / Certificación ISO 9001:2000



**Forno - Tratamentos térmicos**  
 Oven - Thermal treatments  
 / Four - Traitements thermiques  
 / Horno - Tratamientos térmicos



**Compra da Empresa Navit e Criação da Euro Navit**  
 Purchase of the Navit Company and Creation of Euro Navit  
 / Achat de la Société Navit et Création de Euro Navit  
 / Compra de la Empresa Navit y Creación de Euro Navit

**1ª Convenção de Vendas**  
 1st Sales Convention  
 / 1ere Convention de Ventes  
 / 1ª Convención de Ventas



1986

1995

2000

**FIXART**

**Criação da Marca Fixart**  
Creation of the Fixart Brand  
/ Création de la Marque Fixart  
/ Creación de la marca Fixart



**Início da Pecol Itália**  
Beginning of Pecol Italy  
/ Lancement de Pecol Italie  
/ Inicio de la Pecol Italia

**LOCEP**  
Indústrias Metálicas, Lda

**Criação da Empresa LOCEP em Angola**  
Creation of the LOCEP Company in Angola  
/ Création de la Société LOCEP à Angola  
/ Creación de la empresa LOCEP en Angola



**Aquisição da INKATOR (Espanha)**  
Acquisition of INKATOR (Spain)  
/ Acquisition de INKATOR (Espagne)  
/ Adquisición de INKATOR (España)

**Parafusos Marcação CE**  
CE Marking Screws  
/ Vis Marquage CE  
/ Tornillos Marcado CE



**Ampliação da INKATOR (Espanha)**  
Enlargement of INKATOR (Spain)  
/ Agrandissement de INKATOR (Espagne)  
/ Ampliación de INKATOR (España)



**Compra da Loja "Casa dos Parafusos" (Lisboa)**  
Purchase of the Shop "Casa dos Parafusos" (Lisbon) / Achat du Magasin "Casa dos Parafusos" (Lisbonne) / Compra de tienda "Casa dos Parafusos" (Lisboa)

**Lançamento do ISIG**  
Launch of ISIG  
/ Lancement de ISIG  
/ Lanzamiento del ISIG



**Entrega de iPads aos vendedores**  
Delivery of iPads to sellers  
/ Livraison d'iPads aux vendeurs  
/ Entrega de iPads a los vendedores



**Início da Pecol Polónia**  
Beginning of Pecol Poland  
/ Lancement de Pecol Pologne  
/ Inicio de la Pecol Polonia



**Aquisição da Empresa SERMOCOL**  
Acquisition of the SERMOCOL Company  
/ Acquisition de la Société SERMOCOL  
/ Adquisición de la empresa SERMOCOL



**Abertura Filial de Braga**  
Opening of Braga Subsidiary  
/ Ouverture de la Filiale de Braga  
/ Apertura de Sucursal de Braga

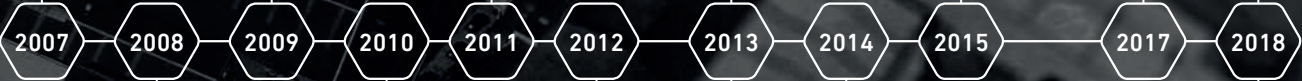

**25 ANOS**

**Aquisição da Torge (Espanha)**  
Acquisition of Torge (Spain)  
/ Acquisition de Torge (Espagne)  
/ Adquisición de Torge (España)



**Início da Pecol Brasil**  
Beginning of Pecol Brasil  
/ Lancement de Pecol Brasil  
/ Inicio de Pecol Brasil



**Criação Linha de Embalagem**  
Creation of Packaging Line  
/ Mise en place de la Ligne de Conditionnement  
/ Creación de Línea de Embalaje



**Pecol Fijaciones (Espanha)**  
Pecol Fijaciones (Spain)  
/ Pecol Fijaciones (Espagne)  
/ Pecol Fijaciones (España)

**Certificação AENOR para a Empresa Pecol 2**  
AENOR Certification for Pecol Company 2 / Certification AENOR pour la Société Pecol 2 / Certificación AENOR para la Empresa Pecol 2



**PECOL**  
automotive

**Criação da Marca Pecol Automotive em substituição da Pecol 2**  
Creation of the Pecol Automotive Brand in replace of Pecol 2 / Création de la Marque Pecol Automotive à la place de Pecol 2 / Creación de la marca Pecol Automotive en sustitución de Pecol 2

**PECOL GROUP 35**  
1983-2018

**Envio de encomendas de forma eletrónica**  
Sending orders electronically  
/ Envoi d'ordres par voie électronique / Envío de pedidos de forma electrónica



**30 anos**  
1983-2013



2009



2011



2018



No âmbito da comercialização e distribuição de Parafusaria

/ As part of the commercialisation and distribution of fasteners / Dans le contexte de la commercialisation et visserie de distribution  
/ Ámbito de comercialización y distribución de fijaciones y tornillería

## PRODUTOS DE QUALIDADE

Todos os produtos comercializados com a marca Pecol® respeitam os mais elevados parâmetros de qualidade e são regularmente testados nos nossos laboratórios.

A Certificação ISO 9001/2008 foi o resultado de uma atitude e um esforço de melhoria contínua determinada pela satisfação permanente das necessidades dos clientes.

A Pecol considera a sua política de Qualidade como uma prioridade do seu desenvolvimento sustentado, como um investimento seguro para a fidelização dos seus clientes e como fator de consolidação da visão empresarial e da sua filosofia de gestão.

Exemplo disso é o sistema de gestão ambiental da pecol que é certificado de acordo com a norma ISO 14001.

### QUALITY PRODUCTS

All products marketed under the Pecol® brand comply with the highest quality requirements and are regularly tested in our laboratories. The ISO 9001/2008 Standard Certification is the result of a continuous improvement effort and of an attitude determined by the permanent satisfaction of our clients needs. PECOL's quality policy is our priority and our strong investment.

An example is the environmental management system of Pecol that is certified according to ISO 14001.

### PRODUITS DE QUALITÉ

Tous les produits vendus sous la marque Pecol® respectent le plus hautes normes de qualité et sont régulièrement testés dans nos laboratoires.

L'ISO 9001/2008 a été le résultat de notre attitude et du effort d'amélioration continue que vise la satisfaction de besoins de notre clientèle.

Pecol considère sa politique de qualité une priorité de son développement continu, un investissement sûr que vise obtenir la fidélité de ses clients et comme un facteur de consolidation de la vision d'entreprise et sa philosophie de gestion. Un des exemples c'est le système de gestion d'environnement pour lequel Pecol est certifié en accord avec la norme ISO 14001.

### PRODUCTOS DE CALIDAD

Todos los productos comercializados bajo la marca Pecol® satisfacen los más altos parámetros de calidad y son testados periódicamente en nuestros laboratorios.

La norma ISO 9001/2008 fue el resultado de una actitud y un esfuerzo de mejora continua determinado por la satisfacción permanente de las necesidades del cliente. Pecol considera su Política de Calidad como una prioridad de su desarrollo sostenible, como una inversión segura para la fidelización de sus clientes y como factor de consolidación de la visión empresarial y su filosofía de gestión.

Un ejemplo de esto es el sistema de gestión ambiental de Pecol que está certificado según la norma ISO 14001.

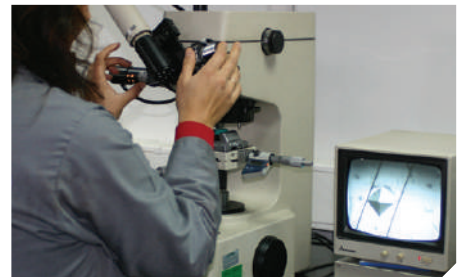
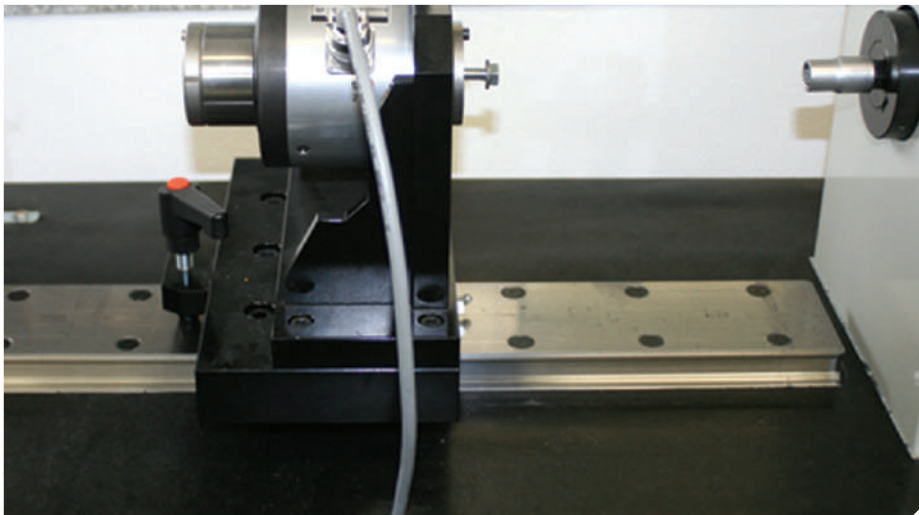



## FORMAÇÃO TÉCNICA



A aposta da Pecol na formação contínua dos seus colaboradores, nomeadamente na área comercial, é um dos grandes fatores diferenciadores e uma forte vantagem competitiva.

A capacidade técnica dos nossos vendedores e o

profundo conhecimento dos produtos, a par da sua permanente disponibilidade, fazem da Pecol o parceiro de eleição e uma reconhecida mais-valia no aconselhamento quanto aos produtos mais adequados para cada tipo de aplicação.

## A EQUIPA COMERCIAL

A nossa principal preocupação é disponibilizar um conjunto de produtos e soluções de fixação e montagem, que tornem mais fácil o trabalho dos nossos clientes, nas diversas áreas da indústria e da construção.

Para isso, dispomos de uma equipa de vendas com mais de 100 colaboradores, que todos os dias reforçam os laços de proximidade com os nossos 25.000 clientes, através de um apoio técnico e comercial competente e de uma partilha de experiências que visa o melhor entendimento profissional.

A nossa força de vendas está equipada com o mais moderno equipamento informático, que permite aceder e utilizar toda a informação relevante sobre o cliente e ao mesmo tempo, transmitir as encomendas e fazer outras consultas em tempo real para a sede da empresa.

### COMMERCIAL TEAM

*Our main goal is to provide a wide range of fixing and assembly products and solutions that allow our clients to work easier in the different kind of industry and construction areas. We have a sales team with more than 100 sales reps that maintain a strong partnership with our 25,000 clients through a competent technical and commercial support and experience sharing that aims at enhancing professional understanding. Our Sales force is equipped with the most modern IT equipment which allows them to access and use all relevant information on the client and simultaneously book the orders online and make other enquiries in real time to the company's head office.*

### L'ÉQUIPE COMMERCIAL

*Notre principale préoccupation est fournir un ensemble de solutions de fixation qui rendent plus facile le travail de nos clients dans les différents domaines de l'industrie et la construction. Pour cela, nous avons une équipe de vente avec plus de 100 employés, que tous les jours renforcent les liens avec nos 25,000 clients par le biais un support technique et commercial compétent et un partage d'expériences visant à meilleure compréhension professionnelle. Notre équipe de ventes est équipé d'équipements informatiques modernes, qui permettent accéder à toutes les informations pertinents pour le client et au même temps, transmettre les commandes en temps réel au siège.*

### EL EQUIPO COMERCIAL

*Nuestra principal preocupación es proporcionar un conjunto de productos y soluciones de fijación y montaje, por hagan más fácil el trabajo de nuestros clientes en las distintos áreas de la industria y la construcción. Para ello, disponemos de un equipo de ventas con más de 100 empleados, que todos los días refuerzan los estrechos vínculos de nuestros más de 25,000 clientes a través de un soporte técnico y comercial competente y un intercambio de experiencias que proporcionan una mejor comprensión profesional. Nuestro equipo de ventas está equipado con más modernos equipos informáticos, los cuales permiten el acceso y el uso de toda la información relevante para el cliente y, al mismo tiempo, realizar pedidos y hacer otras consultas en tiempo real a la sede de la empresa.*

### TECHNICAL TRAINING

*Pecol's focus on employee training, is a major differentiating factor and a strong competitive advantage.*

*The technical expertise of our salesmen and the deep knowledge of the products, along with their 24 hour/day availability, make PECOL a privileged partner for even the most demanding costumers which can count on the counselling of the most adequate products for each type of use, generating a real benefit for the costumers.*

### FORMATION TECHNIQUE

*Pecol mise dans la formation continue des ses employés, en particulier dans le département commercial, ceci est un des principaux facteurs de différenciation et une forte avantage compétitive.*

*Les compétences technique de nos commerciales, sa connaissance des produits, ainsi que sa disponibilité permanente, font de Pecol el socio idéal y de reconocido valor añadido en cuanto a la prescripción de los productos más adecuados para cada tipo de aplicación.*

### FORMACIÓN TÉCNICA

*La apuesta de Pecol en la formación continua de sus empleados, sobre todo en la zona comercial, es uno de los principales factores diferenciadores y una fuerte ventaja competitiva.*

*La capacidad técnica de nuestros proveedores y su profundo conocimiento de los productos, junto con su disponibilidad permanente, hacen de Pecol el socio ideal y de reconocido valor añadido en cuanto a la prescripción de los productos más adecuados para cada tipo de aplicación.*





## LOGÍSTICA

Cerca de 40.000 referências num único fornecedor, com uma variedade de produtos destinados a profissionais.

Expedição para qualquer ponto do País, segundo as condições gerais de venda.

Entregas sem surpresas, sem falhas e sem outros custos escondidos.

Delegações em vários pontos do País, o que permite o contacto direto com os produtos e garante a satisfação de uma necessidade urgente e uma maior proximidade.

Sistema de etiquetagem de produtos que disponibiliza na embalagem toda a informação necessária, incluindo número de lote e código de barras.

Estas são as razões que tornam a Pecol um parceiro fiável e de reconhecido valor pela maioria dos clientes profissionais.



### LOGISTICS

Availability of more than 40,000 references in a single supplier, with a wide range of products for professionals and trade. Deliveries to any region of the continental Country, according to General Sales Terms.

Deliveries with no surprises, zero defects and no hidden costs.

Subsidiaries throughout the Country, which allow a direct contact with the products and ensures greater proximity and reliability in case of urgent demands. The product labelling system provides all information required on the package, including batch number and barcode.

These are the several reasons that make Pecol a reliable and valuable partner, acknowledged by most professional clients.

### LOGISTIQUE

Environ 40.000 références dans une seule fournisseur, avec une grande variété de produits destinés aux professionnels.

Livraison dans tous les points du pays, selon les conditions générales de vente.

Livraison sans surprises, sans défaissances ou autres coûts cachés.

Bureaux dans diverses régions du pays, qui permettent un contact direct avec les produits et permet la satisfaction des besoins plus urgents.

Système d'étiquetage des produits qui fournit toutes les informations sur l'emballage nécessaires, y compris le numéro de lot et le code bars.

Ce sont les raisons qui font un Pecol un partenaire fiable et reconnu par la plupart des clients professionnels.

### LOGÍSTICA

Alrededor de 40.000 referencias en un único proveedor, con una variedad de productos destinados a los profesionales.

Expedición a cualquier punto del País, según las Condiciones Generales de Venta.

Entregas sin sorpresas, sin defectos ni costes ocultos.

Oficinas en varios puntos del país, lo que permite el contacto directo con los productos y garantiza la satisfacción de una necesidad urgente y mayor proximidad.

Sistema de etiquetado de los productos que Proporciona toda la información necesaria en el envase, incluyendo el número de lote y el código de barras.

Estas son las razones que hacen de Pecol un socio fiable y valioso para la mayoría de los clientes profesionales.

# SISTEMAS DE EMBALAGEM

## Segmento Profissional

Dispomos de linhas de embalagem de caixas de cartão totalmente automatizadas, adequadas às exigências dos profissionais da fixação. O sistema de etiquetagem dos produtos disponibiliza toda a informação necessária, incluindo número de lote e código de barras.

## Segmento Industrial

As linhas de embalagem em saco são especialmente dedicadas para clientes industriais e permitem uma grande flexibilidade e adaptação às necessidades de cada um dos clientes deste setor.

## Segmento Retalho

As linhas de embalagem em blister disponibilizam aos nossos clientes do retalho uma embalagem inovadora, atrativa, informativa e extremamente funcional para os seus espaços comerciais. Estas embalagens permitem criar espaços dentro da loja de forma organizada e extremamente atrativa para o consumidor final.

A Pecol tem a capacidade de disponibilizar diversos tipos de embalagem de acordo com as especificidades do segmento de cada cliente.

## PACKAGING SYSTEMS

### Professional Segment

We have full-automatic packing lines for carton boxes especially designed to fulfill the requirements of our professional clients. The product labeling system provides all the necessary information, including batch number and bar code.

### Industrial Segment

The polybag packing lines for industrial clients allow a great flexibility and adjustment to their needs. These lines are specially dedicated to provide a professional service of packaging kits of one or more items to integrate in the products of our clients.

### Retail Segment

The blister packing lines offers our retail clients an innovative, attractive, informative and extremely functional packaging for commercial areas. These packages allow the creation of organized areas in the store and are extremely attractive to the final DIY consumer.

Pecol is able to offer different types of packages, according to the specificities of each market segment.

## SYSTÈMES D'EMBALLAGE

### Segment Professionnel

Nous avons des lignes d'emballage en boîtes de carton entièrement automatisées, adaptées aux exigences des professionnelles de la fixation. Le système d'étiquetage des produits fournit toutes les informations nécessaires, y compris le numéro de lot et le code à barres.

### Segment industriel

Les lignes de conditionnement en sac sont particulièrement dédiés aux clients industriels et permettent une grande flexibilité et adaptation aux besoins de chaque client dans le secteur.

### Segment Bricolage

Les lignes d'emballage blister offrent à nos clients de détail un packaging innovant, attrayant, instructif et très fonctionnel pour ses espaces commerciaux. Ces emballages vous permettent de créer des espaces de façon organisée, extrêmement attractives pour le consommateur final.

Pecol a la capacité de fournir différents types d'emballage selon le segment spécifique de chaque client.

## SISTEMAS DE EMBALAGEM

### Segmento profesional

Tenemos líneas de envasado de cajas de cartón totalmente automáticas, adecuadas a las exigencias de los profesionales de la fijación. El sistema de etiquetado proporciona a los productos toda la información necesaria, incluyendo el número de lote y código de barras.

### Segmento Industrial

Las líneas de envasado en bolsa están dedicados especialmente a los clientes industriales y permiten gran flexibilidad y adaptación a las necesidades de cada cliente en este sector.

### Segmento Minorista

Las líneas de envasado en blister proporcionan a nuestros clientes el embalaje al por menor innovador, atractivo, informativo y extremadamente funcional para sus espacios comerciales. Estos embalajes permiten crear espacios dentro de la tienda muy organizados y atractivos para el consumidor final.

Pecol tiene la capacidad de proporcionar diversos tipos de embalaje de acuerdo con las características específicas del segmento de cada cliente.



# ROTULAGEM DE PRODUTOS

O rótulo de cada produto é aplicado sobre a caixa. É de leitura fácil e imediata.

- 1 - Código de Artigo
- 2 - Desenho
- 3 - Descrição
- 4 - Norma Internacional (DIN / PCL / ISO)
- 5 - Tratamento
- 6 - Diâmetro e comprimento da peça
- 7 - Quantidade por embalagem
- 8 - Matéria Prima
- 9 - Lote de produção
- 10 - Código de barras EAN13

## PRODUCT LABELLING / ÉTIQUETAGE DES PRODUITS / ETIQUETADO DE PRODUCTOS

The label of each product is applied on the box. It can be easily and quickly read / L'étiquette de chaque produit est appliqué sur la boîte. Lecture facile et immédiate / La etiqueta de cada producto se aplica sobre la caja. De lectura fácil e inmediata.

- 1 - Item code / Code d'article / Código de artículo
- 2 - Layout / Image / Diseño
- 3 - Description / Description / Descripción
- 4 - International Standard / Norme internationale / Norma Internacional (DIN/PCL/ISO)
- 5 - Treatment / Traitement / Tratamiento
- 6 - Part Diameter and length / Diamètre et longueur de la pièce / Diámetro y la longitud de la pieza
- 7 - Units per package / Quantité / Cantidad por embalaje
- 8 - Raw material / Matières premières / Materias Primas
- 9 - Manufacturing batch / Lot de production / Lote de Producción
- 10 - EAN13 bar code / Code de barres EAN13 / Código de barras EAN13

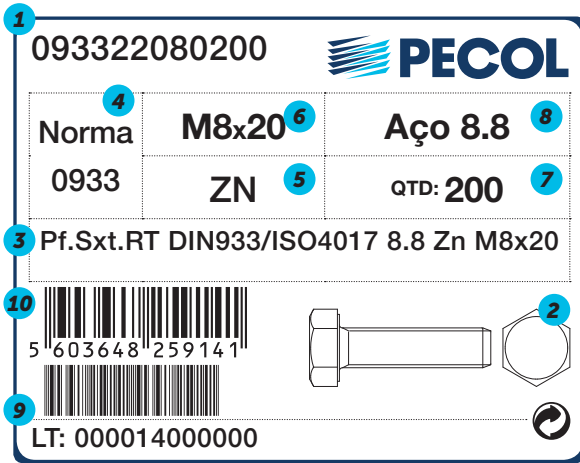

## 1 CÓDIGO DE ARTIGO

0965 1 1 030100

AAAA B C DDDDDD

NORMA (DIN/PCL/ISO)

MATÉRIA PRIMA /

1 - Ferro 3 - 10.9 5 - Latão 7 - Inox A4 9 - Cobre  
2 - 8.8 4 - 12.9 6 - Inox A2 8 - Alumínio

ACABAMENTO /

1 - SAG 3 - Passivado amarelo 5 - Niquelado 7 - Oxidado 9 - Geomet / Dacromet / G.Q.  
2 - Zincado 4 - Granalhado / selante 6 - Latonado 8 - Bronze

DIMENSÃO

### (1) ITEM CODE / CODE D'ARTICLE / CÓDIGO DEL ARTÍCULO

**A** - International Standard / Norme internationale / Norma (DIN/PCL/ISO)

**B** - Raw Material / Matières premières / Materia prima

**C** - Treatment / Traitement / Acabado

**D** - Dimensions / Dimensions / Dimensiones

- 1 - Iron / Fer / Hierro
- 2 - 8.8
- 3 - 10.9
- 4 - 12.9
- 5 - Brass / Laiton / Latón
- 6 - Stainless Steel A2 / Inox A2 / Inox A2
- 7 - Stainless Steel A4 / Inox A4 / Inox A4
- 8 - Aluminium / Aluminium / Aluminio
- 9 - Copper / Cuivre / Cobre

- 1 - Without surface coating / Sans traitement / Sin recubrimiento
- 2 - Zinc Plated / Zingué / Zn
- 3 - Yellow Zinc / PA / PA.
- 4 - Blasted | Sealant / grenailée | mastic / Granallado | sellado
- 5 - Nickel Plated / nickel / Niquelado
- 6 - Brass / Laiton / Latonado
- 7 - Oxidised / oxydée / Oxidado
- 8 - Bronze / Bronze / Bronze
- 9 - Geomet | Dacromet | Galvanised | Geomet | dacromet | Galvanisé a chaud / Geomet | Dacromet | G.Q.

# PEÇAS ESPECIAIS

O Grupo PECOL, nomeadamente as empresas de estampagem a frio em Portugal e Espanha, estão equipadas com meios produtivos modernos e dotadas da melhor tecnologia utilizada no setor. Essa tecnologia aliada a um departamento de Engenharia dotado de uma equipa altamente qualificada, com know-how adquirido através de formação constante e projetos cada vez mais complexos, proporcionam a produção de um alargado portfólio de peças especiais em diversos tipos de materiais (ex. aço, inox, latão, alumínio e cobre).

Grande percentagem deste portfólio é destinada à indústria automóvel com aplicação em diversos componentes dos veículos.

## SPECIAL PARTS

The Pecol Group, specifically the cold forming companies in Portugal and Spain are equipped with modern machines and the best technologies used in the sector. This technology coupled with the highly qualified team, with know-how acquired with constant training and high complexity projects, provides the production of an extended portfolio of special parts in different types of materials (example: steel, stainless steel, brass, aluminum and copper).

A large percentage of this production is supplied to the automotive industry with applications in different vehicle components.

## PIÈCES SPÉCIALES

Le Groupe PECOL, notamment les sociétés de frappe a froid au Portugal et Espagne, sont équipés d'installations de production modernes et équipées de la meilleure technologie utilisée dans l'industrie. Cette technologie combinée à un département d'ingénierie équipé d'une équipe hautement qualifiée avec savoir-faire acquis par la formation continu et projets de plus en plus complexes apportent à la production un grand portefeuille de pièces spéciales dans divers types de matériaux (par exemple, acier, acier inoxydable, laiton, aluminium et cuivre).

La grande pourcentage de ce portefeuille est conçu pour l'industrie automobile et appliqué dans divers composants du véhicule.

## PIEZAS ESPECIALES

El Grupo PECOL, incluidas las empresas de estampación en frío en Portugal y España, están equipadas con instalaciones de producción modernas y con la mejor tecnología utilizada en el sector. Esta tecnología se combina con un departamento de ingeniería equipado con un equipo altamente cualificado con un know-how adquirido a través de la formación constante y proyectos cada vez más complejos, que proporciona la producción de una cartera más amplia de piezas especiales en varios tipos de materiales (por ejemplo, acero, acero inoxidable, latón, aluminio y cobre).

Gran porcentaje de esta cartera está diseñada para la industria del automóvil con aplicación en diversos componentes del vehículo.

## SISTEMAS DE ROTAÇÃO

/ Rotation Systems / Systèmes de Rotation / Sistemas De Rotación



EXEMPLOS / Example / Exemples / Ejemplos

- Motor limpa vidro / Wiper system / Moteur d'essuie glaces / Motor de limpiaparabrisas
- Amortecedores de bagageira / Trunk shock absorbers / Amortisseurs de coffres / Amortiguadores de portones

## SISTEMAS ANTI-VIBRAÇÃO

/ Anti-Vibration Systems / Systèmes anti vibration / Sistemas Anti-Vibración

EXEMPLOS / Example / Exemples / Ejemplos

- Casquilhos de amortecedores / Shock absorbers / Douilles amortisseurs / Casquillos de amortiguadores
- Suspensão / Shock absorbers / Suspension / Suspensión
- Suporte de motor / Engine blocks / Support du moteur / Soporte del motor



## PORCAS

/ Nuts / Ecrus / Tuercas



## PF. SOLDAR E CRAVAR

/ Weld and clinching screws / Vis a souder / Soldadura Y Tornillos De Remache



EXEMPLOS / Example / Exemples / Ejemplos

- Utilizados na carroçaria e chassis automóvel / Chassis and metal applications / Utilisés dans la carrosserie / Se utiliza en el la carrocería

## ACESSÓRIOS AUTOMÓVEIS

/ Automotive Accessories / Accessoires de voitures / Accesorios De Automóviles



EXEMPLOS / Example / Exemples / Ejemplos

- Macacos / Jack / Cric / Gato para coche
- Ganchos de reboque / Wheel wrench / Boule de remorque / Ganchos de remotque
- Chave de rodas / Tow bar / Clés des roues / Llave de ruedas

## OUTRAS PEÇAS APLICADAS EM DIFERENTES COMPONENTES DO AUTOMÓVEL

/ Others / Autres pièces utilisés en différents composants automobiles / Otras Piezas Utilizadas En Distintos Componentes Del Automóvil





## TRATAMENTOS TÉRMICOS E DE SUPERFÍCIE

A empresa Pecol tem incorporado no seu processo de produção o tratamento térmico das peças fabricadas, assim como a aplicação de tratamentos de superfície anti corrosivos para todos os seus produtos.

Os tratamentos térmicos são um conjunto de operações de aquecimento a que são submetidas as peças metálicas, em condições controladas de temperatura e atmosfera, que permitem aumentar ou reduzir a dureza do material, incrementando a sua resistência mecânica e ao desgaste.

A nossa unidade de tratamentos térmicos funciona em regime contínuo e tem uma capacidade de produção de 2.000 kg/hora.

O equipamento está preparado para tratamentos de têmpera e revenido, cementação, carbonitruração e recozido a 650°C. A nossa unidade de tratamentos de superfície está preparada para fazer todo o tipo de tratamentos, tais como Geomet<sup>®</sup> (isento de crómio VI), Dacromet<sup>®</sup>, Zincados, (branco, azul, amarelo, iriscente, negro...), Zinco Níquel, Fosfatado e todo o tipo de recobrimentos decorativos como o Niquelado, Latonado e Oxidado.

### HEAT SURFACE TREATMENTS

Pecol company has been incorporating heat treatment of manufactured parts in its manufacturing process, as well as in the application of anti-corrosion surface treatments in all products it produces.

Heat treatments are a set of heating operations to which metal parts are subject, under controlled temperature and atmospheric conditions, which enable the increase or reduction of the material hardness, thereby increasing its mechanical strength and wear resistance.

Our heat treatment unit operated in continuous mode and has a production capacity of 2000 kilos/hour.

Equipment is prepared for quenching and tempering, carburizing, carbonitriding, and annealing at 650°C.

Our surface treatment unit is equipped for performing all types of treatment, such as Geomet<sup>®</sup> (chromium-6 free), Dacromet<sup>®</sup>, Zinc plated, (white, blue, yellow, iridescent, black...), Zinc nickel, phosphate treatment, and all kinds of decorative coatings such as nickel plating, metal embossing, oxidation.

### TRAITEMENT THERMIQUE ET SURFACE

Le traitement thermique de pièces produites chez Pecol est compris dans le processus de production, ainsi que l'application traitements anticorrosion pour tous ses produits.

Les traitements thermiques sont un ensemble des opérations de chauffage a lesquelles les pièces métalliques sont soumises. A une température et atmosphère contrôlé ce qui permet augmenter ou diminuer la dureté des matériaux, ce qui augmente sa résistance et retarde l'usure de la pièce.

Notre unité de traitement thermique travaille en continu et a une capacité de production de 2000 kg / heure.

L'équipement est préparé pour les traitements de température, revêtement, cémentation, carbonitruration et recuit à 650°C.

Notre unité de traitement de surface est prêt à faire toutes sortes de des traitements tels que GEOMET<sup>®</sup> (sans chrome VI), DACROMET<sup>®</sup>, Zingué (blanc, bleu, jaune, noir...), Zinc Nickel, Phosphaté et toutes sortes de revêtements décoratifs comme le nickel et Laiton Oxydé.

### TRATAMIENTOS TÉRMICOS Y SUPERFICIALES

Pecol ha incorporado en su proceso de producción un tratamiento térmico de las piezas fabricadas, así como la aplicación de tratamientos superficiales anticorrosivo para todos sus productos.

Los tratamientos térmicos son un conjunto operaciones de calentamiento a las que se son sometidas las piezas metálicas en condiciones de temperatura y atmósfera controladas, que permiten aumentar o reducir la dureza de materiales, aumentando su resistencia mecánica y al desgaste.

Nuestra unidad de tratamientos térmicos trabaja en continuo y tiene una capacidad de producción de 2.000 kg / hora.

El equipo está preparado para tratamientos de temple y revenido, cementación, carbonitruración y recocido a 650°C.

Nuestra unidad de tratamientos superficiales Está preparado para hacer todo tipo de tratamientos como GEOMET<sup>®</sup> (exento de cromo VI), DACROMET<sup>®</sup>, Zincados (blanco, azul, amarillo, iriscente, negro...), Zinc Níquel, Fosfatado y todo tipo de recubrimientos decorativos como Niquelado, Latonado y Oxidado.



# ACABAMENTOS

Os vários tipos de acabamentos disponíveis.

## SURFACE TREATMENT / TRAITEMENTS / ACABADOS

The various types of Surface Treatment available / Tipos de tratamentos disponíveis / Tipos de acabados disponíveis

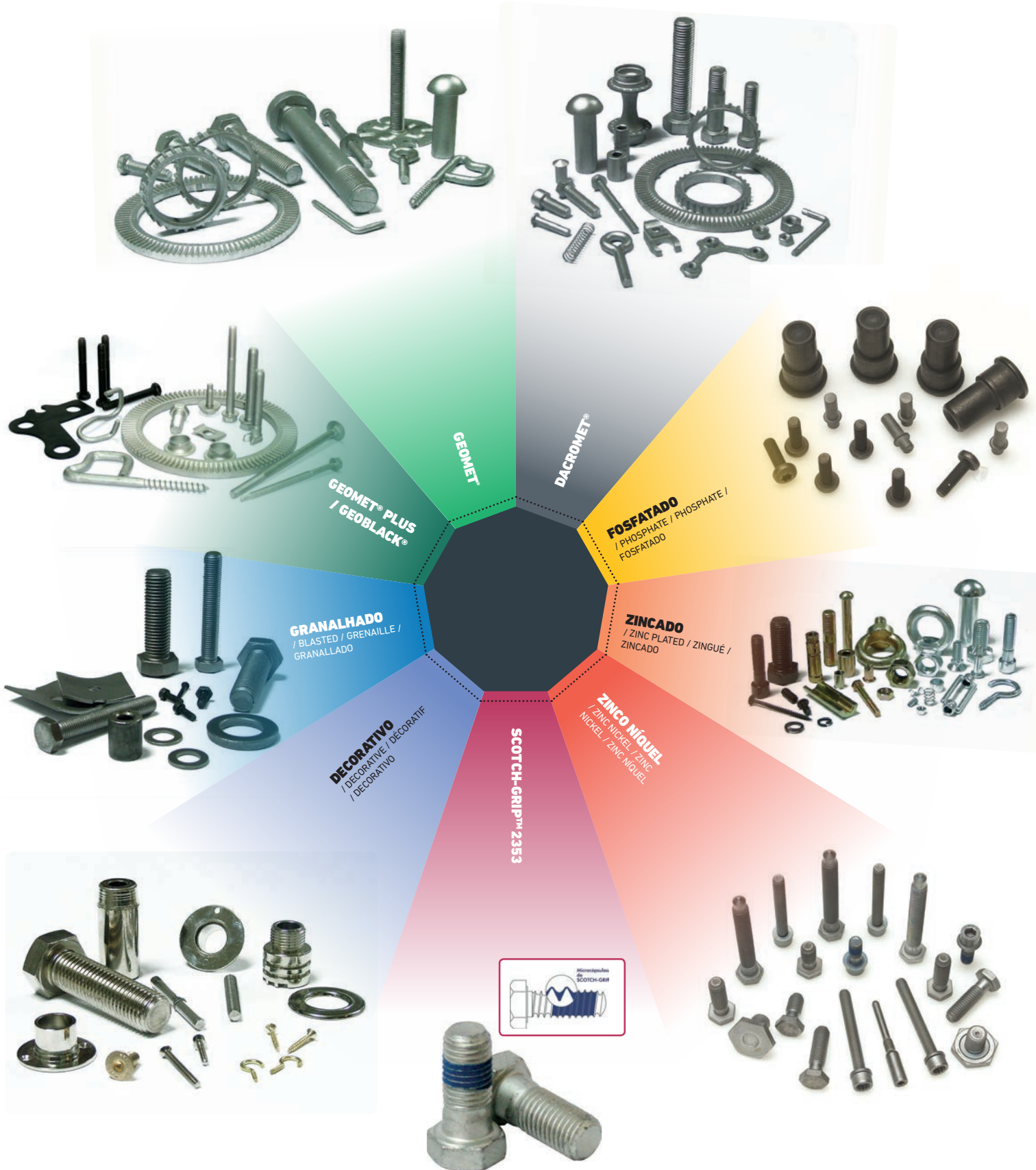

# GEOMET® vs Outros tratamentos

/ GEOMET® versus other treatments / GEOMET® vs Autres traitements / GEOMET® vs Otros tratamientos

## GEOMET PLUS / GEOBLACK

O **GEOMET PLUS** é composto por uma primeira camada de Geomet e uma camada de selante PLUS L, VL, M, ML, XL.

É especialmente indicado para peças de segurança e tem as seguintes características:

- Mantém o aspeto físico da peça com lubrificante integrado;
- Aumento da resistência à corrosão das peças durante a utilização e às agressões mecânicas;
- Melhora a proteção contra a corrosão de contacto;
- Boa resistência a solventes, carburantes e líquidos de travão;
- Preço de custo competitivo.

The **GEOMET PLUS** is composed of a first layer of Geomet and a layer of sealant PLUS L, VL, M, ML, XL.

It is particularly suitable for safety parts and has the following characteristics:

- Maintains the physical aspect of the piece with integrated lubricant;
- Increases the resistance to corrosion of parts during use and mechanical stress;
- Improves protection against contact corrosion;
- Good resistance to solvents, fuels and brake fluids;
- Competitive cost price.

Le **GEOMET PLUS** est composé d'une première couche de Geomet et une couche de mastic PLUS L, VL, M, ML, XL. Il est particulièrement indiqué pour pièces de sécurité et présente les caractéristiques suivantes:

- Maintient l'aspect physique de la pièce avec lubrifiant intégré;
- Augmentation de la résistance à la corrosion des pièces pendant l'utilisation et contraintes mécaniques;
- Améliore la protection contre la corrosion de contact;
- Bonne résistance aux solvants, carburants et les liquides de frein;
- Prix de coût compétitif.

**GEOMET PLUS** se compone de una primera capa de Geomet y una capa sellante PLUS L, VL, M, ML, XL. Es especialmente adecuado para piezas de seguridad y tiene las siguientes características:

- Mantiene el aspecto físico de la pieza con lubricante integrado;
- Aumento de la resistencia a la corrosión de las piezas y a las agresiones mecánicas durante el uso;
- Mejora la protección contra la corrosión por contacto;
- Buena resistencia a los solventes, combustibles y líquidos de frenos;
- precio de coste competitivo.

**GEOBLACK** é um revestimento negro não eletrolítico de baixa espessura composto por zinco e alumínio, dentro de uma matriz mineral sem cromo nem metais pesados para a proteção contra a corrosão de peças em aço, fundidas ou materiais metálicos ferrosos. A sua cor preta advém de uma composição de Geomet 321 e uma camada de selante plus black. Processo conseguido por imersão em frio ou pulverização.

**GEOBLACK** is a black non-electrolytic coating of small thickness composed of zinc and aluminum, inside a mineral matrix without chromium or heavy metals for protection against corrosion of steel parts, cast iron or ferrous metallic materials. Its black color comes from a composition of Geomet 321 and a layer of PLUS BLACK sealant. Process achieved by cold immersion or spraying.

**GEOBLACK** est un revêtement noir, non électrolytique de faible épaisseur composé de zinc et d'aluminium, dans une matrice minérale sans chrome ni métaux lourds pour la protection contre la corrosion de pièces en acier et matériaux métalliques non ferreux. Sa couleur noire provient d'une composition de Geomet 321 et une couche de mastic PLUS BLACK. Processus réalisé par immersion dans le froid ou pulvérisation.

**GEOBLACK** es un recubrimiento negro no electrolítico de bajo espesor compuesto de zinc y aluminio, dentro de una matriz mineral sin cromo ni metales pesados para la protección contra la corrosión de piezas de acero, hierro fundido o de materiales metálicos ferrosos. Su color negro proviene de una composición Geomet 321 y una capa de sellador PLUS BLACK. Proceso consigue por inmersión en frío o de pulverización.

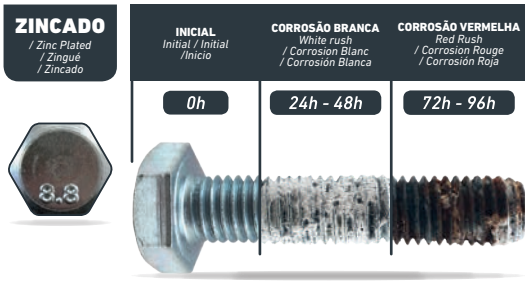
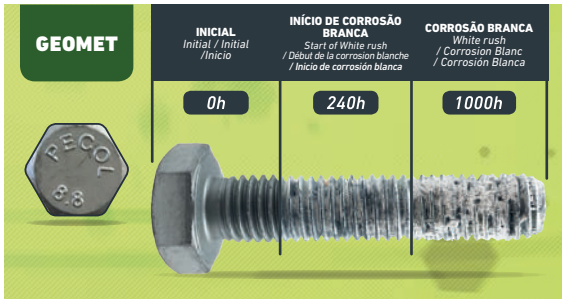

**ACABAMENTO / Surface Treatment / Traitements / Acabados**

# GEOMET®

**ISENTO DE CRÓMIO**  
Chromium free / Sans chrome / Exento de Cromo

**TRATAMENTOS DISPONÍVEIS EM:**  
Treatments available in: / Traitements disponibles en: / Tratamiento disponibles en:

**RETS COAT**  
PECOL GROUP

✓ **REVESTIMENTO ECOLÓGICO DE BASE AQUOSA COMPOSTO POR ZINCO E ALUMÍNIO**  
Ecological water-based coating consisting of zinc and aluminum / Revêtement écologique à base d'eau composé de zinc et d'aluminium / Revestimiento ecológico de base acuosa, compuesto por zinc y aluminio

✓ **ELEVADA RESISTÊNCIA À CORROSÃO GRAU AO CALOR E A PRODUTOS QUÍMICOS**  
High resistance to corrosion, heat and chemicals / Haute résistance à la corrosion, à la chaleur et aux produits chimiques / Elevada resistencia a la corrosión grado, al calor y a los productos químicos

✓ **LUBRIFICAÇÃO INTEGRADA, REDUZINDO O ATRITO DURANTE O APERTO**  
Integrated lubrication, reducing friction during tightening / Lubrification intégrée, réduisant les frottements lors du serrage / Lubricación integrada, reduciendo el fricción durante el apriete

✓ **AUSÊNCIA DE FRAGILIZAÇÃO POR HIDROGÉNIO**  
Good electrical conductivity / Bonne conductivité électrique / Ausencia de fragilización por hidrógeno

✓ **CONFORME NORMATIVA REACH**  
In accordance with REACH / Conforme à la normative REACH / Conforme a la normativa REACH

**TESTES EFETUADOS EM AMBIENTE CONTROLADO DE CAMARA DE NEVOEIRA SALINO**  
/ Tests carried out in the controlled environment of a saline mist chamber / Des essais effectués dans un environnement contrôlé de chambre de brouillard salin / Pruebas efectuadas en un ambiente controlado de cámara de niebla salina

Revestimento Coatings / Revêtement / Recubrimiento	Espessura / Thicknesses / Epaisseur / Espesor	Corrosão Branca / White rush / Corrosion Blanc / Corrosion Blanca	Corrosão Vermelha / Red Rush / Corrosion Rouge / Corrosion Roja	CoF
	µm	Horas / Hours	Horas / Hours	
Geomet 500 Grau A / Geomet 500 - Grade A / Geomet 500 Grade A / Geomet 500 Grado A	6	240	600	[0,12 - 0,18]
Geomet 500 Grau B / Geomet 500 - Grade B / Geomet 500 Grade B / Geomet 500 Grado B	8	240	1000	[0,12 - 0,18]
Geomet 321 - Grau A / Geomet 321 - Grade A / Geomet 321 - Grade A / Geomet 321 - Grado A	6	240	720	
Geomet 321 - Grau B / Geomet 321 - Grade B / Geomet 321 - Grade B / Geomet 321 - Grado B	8	240	1000	
Geomet 321 + PLUS M / Geomet 321 + PLUS M / Geomet 321 + PLUS M / Geomet 321 + PLUS M	8	240	720	[0,12 - 0,18]
Geomet 321 + PLUS ML (EU) / Geomet 321 + PLUS ML (EU) / Geomet 321 + PLUS ML (EU) / Geomet 321 + PLUS ML (EU)	8	240	720	[0,10 - 0,16]
Geomet 321 + PLUS ML (US) / Geomet 321 + PLUS ML (US) / Geomet 321 + PLUS ML (US) / Geomet 321 + PLUS ML (US)	8	240	720	[0,10 - 0,16]
Geomet 321 + PLUS VLH / Geomet 321 + PLUS VLH / Geomet 321 + PLUS VLH / Geomet 321 + PLUS VLH	8	240	720	[0,08 - 0,14]
Geomet 321 + PLUS VL / Geomet 321 + PLUS VL / Geomet 321 + PLUS VL / Geomet 321 + PLUS VL	8	240	720	[0,08 - 0,14]
Geomet 321 + PLUS L / Geomet 321 + PLUS L / Geomet 321 + PLUS L / Geomet 321 + PLUS L	8	240	720	[0,08 - 0,14]
Dacromet 500 - Grau A / Dacromet 500 - Grade A / Dacromet 500 - Grade A / Dacromet 500 - Grado A	6	240	600	[0,12 - 0,18]
Dacromet 500 - Grau B / Dacromet 500 - Grade B / Dacromet 500 - Grade B / Dacromet 500 - Grado B	8	240	1000	[0,12 - 0,18]
Geoblack ML / Geoblack ML / Geoblack ML / Geoblack ML	10	240	800	[0,10 - 0,16]
Geoblack 500 M / Geoblack 500 M / Geoblack 500 M / Geoblack 500 M	10	240	800	[0,11 - 0,17]
Zinco-Níquel Transparente / Translucid Zinc Nickel / Zinc-Nickel Transparent / Zinc-Nickel Transparente	8	120 - 144	480 - 720	
Zinco-Níquel Transparente + Selante / Translucid Zinc Nickel + Sealant / Zinc-Nickel Transparent + Mastic / Zinc-Nickel Transparente + Sellador	8	192 - 240	720	
Zinco-Níquel Transparente + TNT 11 / Translucid Zinc Nickel + TNT 11 / Zinc-Nickel Transparente + TNT 11 / Zinc-Nickel Transparente + TNT 11	8	193 - 240	720	[0,08 - 0,14]
Zinco-Níquel Transparente + TNT 15 / Translucid Zinc Nickel + TNT 15 / Zinc-Nickel Transparente + TNT 15 / Zinc-Nickel Transparente + TNT 15	8	194 - 240	720	[0,12 - 0,18]
Zinco-Níquel Negro / Black Zinc Nickel / Zinc-Nickel Noir / Zinc-Nickel Negro	8	48 - 72	480	
Zinco-Níquel Negro + Selante / Black Zinc Nickel + Sealant / Zinc-Nickel Noir + Mastic / Zinc-Nickel Negro + Sellador	8	144 - 192	720	
Zinco-Níquel Negro + TNT 11 / Black Zinc Nickel + TNT 11 / Zinc-Nickel Noir + TNT 11 / Zinc-Nickel Negro + TNT 11	8	120	720	[0,08 - 0,14]
Zinco-Níquel Negro + TNT 15 / Black Zinc Nickel + TNT 15 / Zinc-Nickel Noir + TNT 15 / Zinc-Nickel Negro + TNT 15	8	120	720	[0,12 - 0,18]
Zinco sem Passivação / Zinc without Passivation / Zingué sans passivation / Zinc sin Pasivado	8	NA	48 - 120	
Zincado Irisado / Iridescent Zinc Plated / Zingué Irisé / Zincado Irisado	8	96 - 120	240	
Zincado Irisado + Selante / Tint11 / Tint15 / Iridescent Zinc Plated + Sealant / Tint11 / Tint15 / Zingué Irisé + Mastic / TNT 11 / TNT15 / Zincado Irisado + Sellador / TNT11 / TNT15	8	144 - 168	480	[0,08 - 0,14] / [0,12 - 0,18]
Zincado Azul / Blue Zinc Plated / Zingué Bleu / Zincado Azul	8	24 - 48	72 - 96	
Zincado Azul + Selante / Tint11 / Tint15 / Blue Zinc Plated + Sealant / Tint11 / Tint15 / Zingué Bleu + Mastic / TNT 11 / TNT15	8	72 - 96	120 - 240	[0,08 - 0,14] / [0,12 - 0,18]
Zincado Preto / Black Zinc Plated / Zingué Noir / Zincado Negro	8	24 - 48	120	
Zincado Preto + Selante / Tint11 / Tint15 / Black Zinc Plated + Sealant / Tint11 / Tint15 / Zingué Noir + Mastic / TNT 11 / TNT15	8	96	240	[0,08 - 0,14] / [0,12 - 0,18]
Zincado Amarelo / Yellow Zinc Plated / Zingué Jaune / Zincado Amarillo	8	96	240	
Zincado Amarelo + Selante / Yellow Zinc Plated + Sealant / Zingué Jaune + Mastic / Zincado Amarillo + Sellador	8	120	400	
Fosfato Manganês / Manganese Phosphate / Phosphate de Manganèse / Fosfato Manganese	10 g/m²	NA	72	
Fosfato Zinco / Zinc Phosphate / Phosphate de Zinc / Fosfato Zinc	10 g/m²	NA	6	
Niquelado / Nickel Plated / Nickel / Niquelado	NA	NA	NA	
Latonado / Laton Brass / Laiton / Latonado	NA	NA	NA	

Nota: os valores são meramente orientativos, dependendo da configuração da peça  
Note: guidance values / Remarque: les valeurs sont purement à titre indicatif, ils varient en fonction de la configuration de la pièce / Nota: Los valores son meramente orientativos, dependiendo de la configuración de la pieza



# FRAGILIZAÇÃO POR HIDROGÉNIO

Durante todo o tipo de processos eletrolíticos (ou tratamentos superficiais), existe uma absorção natural de hidrogénio por parte dos elementos de fixação. Este fenómeno consiste na fragilização da sua resistência podendo chegar, por vezes, à sua rutura.

Infelizmente não é possível eliminar este fenómeno, mas pode-se reduzir o risco de se tornar num problema mais grave. Esta situação é associada a elementos de fixação com dureza superior a 30 HRC e produzidos em aço de carbono ou aço liga.

De forma a neutralizar este fenómeno, é necessário que todos os elementos, após o processo eletrolítico, sejam sujeitos a uma desidrogenação (introduzidos num forno a +200°C) no máximo até uma hora após esse processo eletrolítico.

Durante a cozedura no forno, o objetivo é retirar o hidrogénio através da camada protetora (zincagem).

Esta cozedura é efetuada antes da cromagem ou da aplicação de outro acabamento protetor. A duração desse processo de desidrogenação é variável, consoante as dimensões dos elementos, suas propriedades mecânicas, entre outros.

A eliminação total da fragilidade por absorção de hidrogénio não pode ser garantida. Desta forma, se for necessária uma probabilidade reduzida de fragilidade por absorção de hidrogénio, devem ser considerados procedimentos alternativos.

A PECOL não se responsabiliza por qualquer rutura dos seus produtos resultantes de desidrogenação. Esta situação é igualmente válida para os produtos que sejam por nós comercializados e efetuados tratamentos eletrolíticos posteriores noutros fornecedores.

Para mais informações, não hesite em consultar a norma ISO 4042.

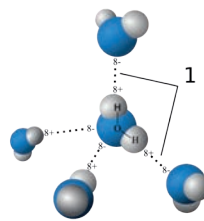

## **HYDROGEN EMBRITTEMENT**

*Throughout the type of electrolytic processes (or surface treatments), there is a natural absorption of hydrogen by the fasteners. This phenomenon consists on the weakening of their resistance, reaching sometimes to its rupture. Unfortunately it is not possible to eliminate this phenomenon, but can reduce the risk of becoming a serious problem. This situation is associated in fasteners with hardness greater than 30 HRC and produced with carbon or alloy steel.*

*In order to counteract this phenomenon, it is necessary that all elements after the electrolytic process, are subject to a dehydrogenation (at +200°C) no later than one hour after this electrolytic process.*

*During baking in the oven, the objective is to remove the hydrogen through the protective layer (zinc).*

*This baking is performed before plating or applying other protective finish. therefore if reduced probability to find the hydrogen embrittlement is required, alternative procedures should be evaluated. PECOL assumes no responsibility for any rupture of its products resulting from dehydrogenation. This is also valid for products that are sold by us and made subsequent electrolytic treatments in other suppliers.*

*Total elimination of brittleness by absorbing hydrogen can not be guaranteed, therefore if reduced probability to find the hydrogen embrittlement is required, alternative procedures should be evaluated. PECOL assumes no responsibility for any rupture of its products resulting from dehydrogenation. This is also valid for products that are sold by us and made subsequent electrolytic treatments in other suppliers.*

*For more information, please consult ISO 4042.*

## **FRAGILISATION A HYDROGENE**

*Au long du procès électrolytiques (Ou des traitements de superficielles), il existe un absorption naturelle de l'hydrogène par les éléments de fixation. Ce phénomène consiste dans l'affaiblissement de sa résistance atteignant parfois à sa rupture.*

*Malheureusement, il est impossible d'éliminer ce phénomène, mais le risque peut être réduit. Cette situation est lié aux éléments de fixation avec une dureté supérieure à 30 HRC et produit l'acier au carbone ou en acier allié.*

*Afin de combattre ce phénomène est nécessaire que tous les éléments après le procès électrolytique soient soumis a déshydrogénation (introduit dans un four à +200 ° C) au plus tard une heure après procès électrolytique.*

*Pendant la cuisson au four, le but est enlever l'hydrogène à travers de la couche protectrice (Galvanisation).*

*Cette cuisson est réalisée avant le chromage ou de l'application d'un autre revêtement protecteur.*

*La durée de ce processus de déshydrogénation est variable en fonction des dimensions des éléments, de leurs propriétés mécaniques, entre autres.*

*L'élimination total de la fragilité de la pièce par absorption d'hydrogène ne peut pas être garanti, donc, si nécessaire une probabilité réduite de fragilisation de la pièce par absorption d'hydrogène d'autres procédures doivent être utilisées. PECOL ne se responsabilise pas par la rupture de ces produits résultat de la déshydrogénation. Ceci est également valable pour les produit commercialisés par nous mais les traitements Electrolytiques sont faites plus tard auprès d'autres fournisseurs.*

*Por plus d'informations, vous pouvez consulter ISO 4042.*

## **FRAGILIZACIÓN POR HIDRÓGENO**

*A lo largo del tipo de procesos electrolíticos (o tratamientos superficiales), existe una absorción natural de hidrógeno por parte de los elementos de fijación. Este fenómeno consiste en el debilitamiento de su resistencia pudiendo llegar incluso a la rotura.*

*Por desgracia, no es posible eliminar este fenómeno, pero se puede reducir el riesgo de convertirse en un problema más serio.*

*Esta situación está asociada a elementos de fijación con dureza superior a 30 HRC y producido acero al carbono o acero de aleación.*

*Con el fin de contrarrestar este fenómeno se requiere que todos los elementos después de un proceso electrolítico, sean sometidos a una deshidrogenación (introducidos en un horno a +200°C) antes de una hora después de este proceso electrolítico.*

*Durante la cocción en el horno, el objetivo es eliminar el hidrógeno a través de la capa de protección (Zincado).*

*Esta cocción se lleva a cabo antes del cromado u otro tratamiento superficial.*

*La duración de este proceso de deshidrogenación es variable en función de las dimensiones de elementos y sus propiedades mecánicas, entre otros.*

*No puede garantizarse la eliminación total de la fragilidad por absorción de hidrógeno, es por ello que si se desea una probabilidad reducida de encontrarse con la fragilidad por absorción de hidrógeno, deberán evaluarse procedimientos alternativos.*

*PECOL no se responsabiliza de cualquier rotura de sus productos resultantes de deshidrogenación. Esto también es válido para los productos comercializados y a los que se apliquen tratamientos electrolíticos posteriores de otros proveedores.*

*Para obtener más información, no dude en consultar la norma ISO 4042.*





PRIMEIRA EMPRESA  
**PORTUGUESA**  
CERTIFICADA  
NO FABRICO DE CONJUNTOS  
DE PARAFUSARIA PARA  
CONSTRUÇÃO, DE ACORDO  
COM AS NORMAS

PECOL is the first portuguese manufacturer certified to produce non-preloading structural bolting assemblies, according to:

PECOL c'est la premier entreprise Portugaise certifiée dans la production de boulonnerie de construction selon les normes

Primera Empresa Portuguesa Certificada En La Fabricación De Los Conjuntos De Tornillería Para Construcción, De Acuerdo Con Las Normas



**EN 15048\***

- Elementos de ligação de construção não sujeitos a pré-esforços;  
/ Non-preloaded structural bolting assemblies;  
/ Boulonnerie de construction non-précontrainte;  
/ Elementos de conexión de construcción no sujetos a pre-esfuerzos;
- Também disponível em inox.  
/ Available for Stainless Steel Screws.  
/ Disponible aussi en acier inoxydable.  
/ También disponible en inox.

- 
- Elementos de ligação de construção de alta resistência sujeita a pré-esforços.  
/ High strength structural bolting assemblies for preloading.  
/ Boulonnerie de construction à haute résistance apte a la précontrainte  
/ Elementos de conexión de construcción de alta resistencia sujetos a pre-esfuerzos.



**EN 14399\***



# ÍNDICE DE PRODUCTOS

INDEX  
INDEX  
ÍNDICE



**PARAFUSOS ROSCA MÉTRICA**  
Metric thread screw / Vis filet métrique / Tornillos rosca métrica

DIN 931 ZN		62
DIN 933 ZN		63
DIN 912 ZN		64
DIN 7380 ZN		64
DIN 7991 ZN		65
DIN 965 ZN		65
DIN 7985 ZN		66
DIN 603 ZN		66
DIN 975 ZN		67
DIN 934 ZN		67
DIN 985 ZN		68
DIN 6923 ZN		68
DIN 127 ZN		68
DIN 125 ZN		69
DIN 9021 ZN		69

PCL 9762 + EPDM		79
DIN 7981 ZN		80
DIN 7981 ZN B		81
DIN 7981 A2		81
DIN 7982 ZN		82
DIN 7983 ZN		83
DIN 6928 ZN		84
PCL8975 + EPDM		85
PCL 8974 ZN		85
EPDM G		86
EPDM A2		86
EPDM AL		86
PF AUTO-ROSCANTE CABEÇA DE EMBEBER PHILLIPS ZN		86
PF AUTO-ROSCANTE CABEÇA DE EMBEBER PHILLIPS A2		87
PF AUTOPERFORANTE CABEÇA DE MENISCO PHILLIPS COM ANILHA ZN		87
PF AUTOPERFORANTE CABEÇA DE MENISCO PHILLIPS COM ANILHA B		87

	79
	80
	81
	81
	82
	83
	84
	85
	85
	86
	86
	86
	86
	87
	87
	87



**PARAFUSOS AUTO-PERFORANTES E AUTO-ROSCANTES**  
Drill and Tapping Screws / Vis autoperceuse et Vis à Tôle / Tornillo autotaladrar y Autoroscante

DIN 7504-K		74
DIN 7504-K PR		74
PCL 9761 - EPDM		75
PCL 9761 - EPDM PR		75
DIN 7504-N A2		76
DIN 7504-N ZN		77
DIN 7504-P ZN		78
BIMETAL		79
BIMETAL + EPDM		79
PCL 9762 PONTA N°5		79



**PARAFUSOS PARA MADEIRA**  
Wood Screws / Vis pour Bois / Tornillos para Madera

PCL 211 ZN		90
PCL 202 ZN Y		92
PCL 202 ZN		93
PCL 205 ZN Y		94
PCL 205 ZN		94
PCL 9830 ZN		95
PCL 232 ZN		95
DIN 571 ZN		96
DIN 571 A2		97
PCL 9800 ZN		97

	90
	92
	93
	94
	94
	95
	95
	96
	97
	97



**REBITES**

Blind rivets / Rivets / Remaches

DIN 7337 A		100
DIN 7337 Co		100
DIN 7337 Al		101
DIN 7337 Al LACADA A COR		102
DIN 7337 A2		103
PCL 7336 Al		103
PCL 7331 Al		104
PCL 7332 Al		104
PCL 7333 Al		104
PCL 7334 Al k10-k14		105
PCL 7335 Al k16		105
PCL 7338 ZN		106
PCL 7338 Co		107
PCL 7338 Co CABEÇA OVAL		107
PCL 7339 Fe		108
PCL 7339 ZN		108
PCL 990 A		109
PCL 909 A2		109
PCL 991 A		109
PCL 991 A2		109
PCL 992 A		110
PCL 992 A2		110
PCL 993 A		110
PCL 993 A2		110



**BUCHAS METÁLICAS**

Metal anchors / Chevilles métalliques / Anclajes Metálicos

PCL 752 ZN		113
PCL 752 A2		113
PCL 753 ETA ZN		116
PCL 753 ETA A4		117
PCL 753 ZN		118
PCL 753 A2		119
PCL 764 6.8 ZN		121
PCL 764 8.8 ZN		121
PCL 764 A2		121
PCL 764 10.9 ZN		122
PCL 764 ZN+A2		122
PCL 764 INOX+A2		122
PCL 764 CAM ZN		122
PCL 764 PIT ZN		123
PCL 782 PFG		123
PCL 783 ZK		124
PCL 784 ZN		126
PCL 784 A2		126
PCL 784 A4		126
PCL 785 6.8 ZN		126
PCL 786 ZN		127
PCL 787 ZN		127
PCL 788 ZN		127
PCL 790 ZN		128
PCL 700 L		129
PCL 325 ZN		129
PCL 755 ZN		129

PCL 650 SR
PCL 6929
PCL 6929 + EPDM
PITÃO P/ ANDAIMES / Scaffolding anchoring
PCL 500 C/ BORDO / PCL 500 Rimmed
PCL 500 S/ BORDO / PCL 500 Rimless
POLEIAS / Air Conditioner Brackets
CINOBLOCO / Rubber pads
PCL 941
CHUMBADORES (OLHAL COM FIEL MONTADO) / Hinge with Stud Mounted



130
131
131
132
132
132
133
133
133
133
133



## BUCHAS PLÁSTICAS

Nylon plug / Chevilles plastiques / Anclajes Plásticos

PCL 518	144
PCL 500 C/ BORDO / PCL 500 Rimmed	146
PCL 500 S/ BORDO / PCL 500 Rimless	146
PCL 502 C/ BORDO / PCL 502 Rimmed	147
PCL 502 S/ BORDO / PCL 502 Rimless	147
PCL 507	147
PCL 501	148
PCL 503	148
PCL 623	148
PCL 618	149
PCL 619	149
PCL 621 ZN+PA	151
PCL 621 ZN+PA	151
PCL 621 A2+PA	151
PCL 622.1 ZN+PA	151
PCL 622 A2+PA	152
PCL 627 ZN+PA	152
PCL 627 A2+PA	152
PCL 123	153
PCL 124	153



## BUCHAS QUÍMICAS

Chemical Anchors / Fixations Chimiques / Anclajes Químicos

VINÍLICA S/ ESTIRENO / Vinylester Styrene Free
EPOXI ACRILATO S/ ESTIRENO / Epoxy Acrylate Styrene Free
EPOXI ACRILATO / Epoxy Acrylate
POLIÉSTER S/ ESTIRENO / Polyester Styrene Free
POLIÉSTER / Polyester
PCL 784 ZN HASTE ROSCADA P/ FIXAÇÃO QUÍMICA (C/ PORCA E ANILHA) / Stud bolt for chemical anchor, with nut and washer
PISTOLA 300ML / Dispenser Gun 300 ml
PISTOLA 300/410ML / Dispenser Gun 300/410 ml
PONTA MISTURADORA / Mixing Nozzle
CAMISA METÁLICA / Internal Threaded Sockets
CAMISA DE NYLON / Plastic Sleeves
BOMBA DE AR / Cleaning Blow Pump
ESCOVILHÃO DE LIMPEZA / Cleaning Brush
MALA DE BUCHA QUÍMICA SPECIAL / Chemical Anchor KIT SPECIAL
MATELA DE BUCHA QUÍMICA CLASSIC / Chemical Anchor KIT CLASSIC



138
139
139
140
140
141
141
141
141
141
141
141
141
141
141
141
141
141
142
142



## ABRÇADEIRAS POLIAMIDA

Cable Ties / Colliers en Polyamide / Abrazaderas Poliamida

PCL 7000 PRETA, TRANSPARENTE E VERDE / Nylon Cable Tie - Black, Transparent and Green	156 - 157
PCL 7001 PRETA / Plug Cable Tie Support - Black	158
PCL 7001 BRANCA / Plug Cable Tie Support - White	158
PCL 118	159

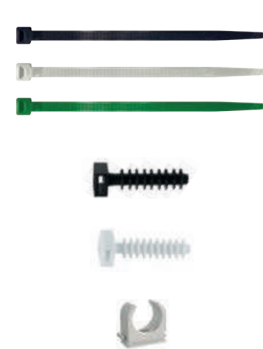

PCL 119
PCL 121
PCL 126
PCL 145 - 1
PCL 145 - 2



159
159
160
160
160

<b>PARAFUSOS PARA CALHA</b> / Channel Stud Nut
<b>PORCAS PARA CALHA PERFORADA</b> / Channel Nuts
<b>PORCA COM MOLLA PARA CALHAS</b> / Channel Spring Nut



172
172
172

**ABRÇADEIRAS METÁLICAS**  
Metallic Clamps / Colliers Métalliques / Abrazaderas Metálicas

PCL 3017 MEB 9 ZN
PCL 3017 MEB 9 A2
PCL 102
PCL 104
PCL 108
PCL 107
PCL 105
PCL 106
ABRÇADEIRA HÉRcules ZN / Robust Clamp ZN
ABRÇADEIRA ESCAPE / Auto Exhaust Clamp
ABRÇADEIRA GÁS / Gas Clamp
PCL 3018
PCL 3017 STRIPSTEEL
UNIBLOCK



162
162
163
163
164
164
164
165
165
166
166
166
167
167
167

<b>FITA DUPLA FACE HD</b> / Double Sided Foam Tape HD
<b>FITA DUPLA FACE LIGHT</b> / Double Sided Eva Foam Tape Light
<b>FITA AMERICANA</b> / Cloth Duct Tape
<b>FITA DE ALUMÍNIO</b> / Aluminium Foil Tape
<b>FITA ADESIVA DE EMBALAGEM</b> / BOPP Packaging Tape
<b>FITA DE PINTURA</b> / Masking Tape
<b>FILME E FITA DE PINTURA</b> / Film and Paper Masking Tape
<b>FITA ISOLADORAS</b> / PVC Insulating Tape
<b>FITA PTFE ÁGUA (TEFLON)</b> / PTFE (Teflon) Tapes - Water
<b>FITA PTFE GÁS (TEFLON)</b> / PTFE (Teflon) Tapes - Gas
<b>FITA DE MARCAÇÃO</b> / PE Warning Tape
<b>FITA DE SILICONE ULTRAFIX TAPE</b> / Silicone Tape UltraFix Tape
<b>FITA DE PAPEL PARA GESSO CARTONADO</b> / Drywall Joint Paper Tape
<b>FITA DE CANTOS PARA GESSO CARTONADO</b> / Metal Corner Drywall Tape
<b>FITA PARA FISSURAS</b> / Fibre Glass Mesh



174
174
174
175
175
176
176
176
176
177
177
177
178
180
180
180

**INSTALADORES**  
Framing Systems / Supportage / Soportacion

<b>SUPORTES PERFORADOS ZN (27 - 38)</b> / Channel Cantilever Arms ZN (27 - 38)
<b>SUPORTES PERFORADOS ZN (41)</b> / Channel Cantilever Arms ZN (41)
<b>ESQUADROS</b> / Channel Bracket
<b>CALHA PERFORADA ZN (20 - 25)</b> / Slotted Strut Channel ZN (20 - 25)
<b>CALHA PERFORADA G (27 - 28 - 38)</b> / Slotted Strut Channel G (27 - 28 - 38)
<b>CALHA PERFORADA G (41)</b> / Slotted Strut Channel G (41)



170
170
170
171
171
171

**VEDAÇÃO E COLAGEM**  
Sealing and Bonding / Étanche et Collage / Sellado y Pegado



<b>SILICONE NEUTRO AL</b> / Neutral Silicone AL
<b>SILICONE NEUTRO</b> / Neutral Silicone
<b>SILICONE NEUTRO SANITÁRIOS</b> / Neutral Sanitary Silicone
<b>SILICONE NEUTRO CONSTRUÇÃO</b> / Neutral Silicone Building Sealant



184 - 185
186 - 187
188
189



SILICONE NEUTRO ALTAS TEMPERATURAS <i>/ High Temperature Neutral Silicone Sealant</i>		190	PISTOLA PU TEFLON SPECIAL <i>/ Teflon Gun SPECIAL</i>		217
SILICONE NEUTRO ALTAS TEMPERATURAS AEROSOL <i>/ High Temperature Neutral Silicone Sealant Aerosol</i>		191			
SILICONE ACETATO <i>/ Acetoxy Silicone</i>		192 - 193	PISTOLA PU SPECIAL E CLASSIC <i>/ Gun SPECIAL and CLASSIC</i>		217
SILICONE ACETATO SANITÁRIOS <i>/ Acetoxy Sanitary Silicone</i>		194			
CORDÃO P/ JUNTAS DE DILATAÇÃO PE <i>/ Polyethylene (PE) Cord</i>		195	SPRAY LIMPEZA ESPUMA P110 <i>/ PU Cleaner P110</i>		217
COLA E VEDA <i>/ Cola &amp; Veda</i>		196 - 197	PEC 31243		220
COLA E VEDA NEUTRO <i>/ Cola &amp; Veda Neutral</i>		198	PEC 31270		220
POWER TACK PECOL		200	PEC 31572		220
MSP 70		201	PEC 31542		220
MSP 50		202	PEC 31577		221
MSP 30		203	PEC 31638		221
MSP CRISTAL <i>/ MSP Crystal</i>		204			
IMPERMEABILIZANTE LÍQUIDO <i>/ Waterproofing Liquid</i>		206	COLA P6 C/ ATIVADOR <i>/ Extra strong adhesive with Activator</i>		222
SELANTE ACRÍLICO <i>/ Acrylic Sealant</i>		207	COLA CIANOACRILATO P1 <i>/ Contact Cyanoacrilate Adhesive - P1 Pen-System</i>		223
SELANTE MADEIRA <i>/ Wood Sealant</i>		208			
COLA PARA SANCAS E MOLDURAS <i>/ Construction Adhesive Solvent-free</i>		209	COLA ESPECIAL P/ PVC P5 <i>/ PVC-U Special Adhesive P5</i>		224
COLA MONTAGEM <i>/ Adhesive Montage Glue</i>		210			
PREGO LÍQUIDO <i>/ Liquid Nail</i>		211	PRODUTO DE LIMPEZA P/ PVC P55 <i>/ PVC Cleaner P55</i>		224
COLA PU EXPRESS MULTIFIBRAS <i>/ Express PU Multifibre Structural Glue</i>		212	COLA POLIURETANO D4 <i>/ D4 PUR Fast Glue</i>		225
SELANTE REFRAATÁRIO <i>/ Fire Sealant</i>		213			
ESPUMA PU B2 MANUAL <i>/ PU Foam B2 Premium - Manual</i>		214	COLA P/ MADEIRA D3/D4 <i>/ Cold Wood Adhesive D3/D4 Fast</i>		226
ESPUMA PU B2 PISTOLÁVEL <i>/ PU Foam B2 Premium - Gun</i>		214			
ESPUMA PU B3 MANUAL <i>/ PU Foam B3 Premium - Manual</i>		215	COLA RÁPIDA P/ MADEIRA D2 <i>/ Cold Wood Adhesive D2 Fast</i>		227
ESPUMA PU B3 PISTOLÁVEL <i>/ PU Foam B3 Premium - Gun</i>		215			
PISTOLA SILICONE <i>/ Caulking Gun</i>		216	COLA DE CONTACTO TIXOTRÓPICA <i>/ Thixotropic Contact Adhesive Gel</i>		227
			CERAS P/ MADEIRA <i>/ Soft Wax in Sticks</i>		228
			BARRA DE COLA TERMOFUSÍVEL <i>/ Hot Melt Glue Stick</i>		229
PISTOLA P/ FOILS <i>/ Aluminium Foils Gun Applicator</i>		216	PISTOLA DE COLA TERMOFUSÍVEL SPECIAL <i>/ Hot Melt Glue Gun SPECIAL</i>		229
CARTUCHO REUTILIZÁVEL ECOSYSTEM <i>/ Reusable Cartridge ECOSYSTEM</i>		216	COLA TERMOFUSÍVEL GRANULADA <i>/ Thermosealing Granular Glue</i>		230 - 231



<b>PW10 EXTERIOR DECK</b> / PW10 Exterior Deck		232	<b>SPRAY LUBRIFICANTE SECO PTFE P 140</b> / PTFE Dry Lube Spray P 140		247
<b>PW10 EXTERIOR ACETINADO</b> / PW10 Exterior Satiny		232	<b>SPRAY ÓLEO CORTE E FURAR P220</b> / Cutting Oil Spray P 220		248
<b>PW10 RENOVADOR</b> / PW10 Renovator		233	<b>SPRAY DESENGORDURANTE INDUSTRIAL P340</b> / P340 Industrial Degreaser Spray		249
<b>PW10 DECAPANTE</b> / PW10 Pickling		233	<b>SPRAY SUPER DETERGENTE P210</b> / Super Cleaner Spray P 210		249
<b>PW10 ÓLEO TEKA</b> / PW10 Oil Teka		233	<b>SPRAY LIMPEZA DE VIDRO E ALUMÍNIO P120</b> / Glass and Aluminium Spray Cleaner P 120		250
<b>PW10 TRATAMENTO</b> / PW10 Treatment		233	<b>SPRAY SILICONE P90</b> / Silicone Spray P 90		250
<b>MASSA P/ JUNTAS DE ALUMÍNIO E PVC P250</b> / Aluminium and PVC Bonding and Sealing Glue		234	<b>SPRAY PROTEÇÃO E LIMPEZA DE AÇO INOX P70</b> / Stainless Steel Care Spray P 70		251
<b>VEDANTE PELÚCIA</b> / Weatherstrips		235	<b>SPRAY LIMPEZA TRAVÕES P290</b> / Brake Cleaner Spray P 290		251
<b>VEDANTE PELÚCIA - STOPFIN</b> / Weatherstrips - StopFin		235	<b>SPRAY REMOV. SILICONES, COLAS E TINTAS P130</b> / Sealant and Adhesive Remover P 130		252
<b>MASSA REPARADORA AQUA</b> / Aqua Epoxy Putty Sticks		236	<b>SPRAY DISSOLVENTE SILICONE P150</b> / Silicone Solvent P 150		252
<b>MASSA REPARADORA COBRE</b> / Copper Epoxy Putty Sticks		236	<b>SPRAY COCKPIT P330</b> / Cleaning and Care Cockpit Spray P 330		253
<b>MASSA REPARADORA AÇO</b> / Steel Epoxy Putty Sticks		236	<b>SPRAY LIMPEZA DE AR CONDICIONADO P350</b> / Air Conditioning Cleaner P 350		253
<b>MASSA REPARADORA PLÁSTICO</b> / Plastic Epoxy Putty Sticks		237	<b>SPRAY PROTETOR DE SOLDADURA P60</b> / Welding Protection Spray P 60		254
<b>MASSA REPARADORA ALUMÍNIO</b> / Aluminium Epoxy Putty Sticks		237	<b>SPRAY PROTETOR DE SOLDADURA P65</b> / Welding Protection Spray P 60		254
<b>MASSA REPARADORA MADEIRA</b> / Wood Epoxy Putty Sticks		237	<b>SPRAY DETETOR DE FUGAS P600</b> / Leak Detector P 600		255
<b>MASSA REPARADORA TITÂNIO</b> / Titanium Epoxy Putty Sticks		237	<b>SPRAY CONTATOS ELÉTRICOS P170</b> / P 170 Electrical Contacts Spray		255
<b>ÓLEO SOLÚVEL P225</b> / Cutting and Cooling Lubricant P225		238	<b>SPRAY COLA P900</b> / Adhesive Spray P 900		256
<b>MASSA CONSISTENTE</b> / Multi Purpose Grease		239	<b>SPRAY ZINCO CLARO P10</b> / Zinc Spray Coating Bright Colour P10		257
<b>PISTOLA DE APLICAÇÃO P/ MASSA DE RENDIMENTO</b> / Application gun for Multi Purpose Grease		239	<b>SPRAY ZINCO BRILHANTE P15</b> / Zinc Spray Coating Bright Colour P15		257
<b>GEL PASSA CABOS</b> / Gliss Gel		240	<b>SPRAY ZINCO ESCURO P20</b> / Zinc Spray Coating Dark Colour P20		258
<b>PELÍCULA PROTETORA INVISÍVEL PARA VIDRO</b> / Invisible Glass Protective Film		241	<b>SPRAY ZINCO MATE P25</b> / Zinc Spray Coating Dark Colour P25		258



**SPRAYS**  
Sprays / Sprays / Sprays

<b>SPRAY TURBO P50</b> / Spray Turbo P 50 PREMIUM		245	<b>SPRAY ALUMÍNIO P40</b> / Aluminium Spray P 40 PREMIUM		259
<b>SPRAY LUBRIFICANTE MULTIUSOS P240</b> / Penetrating Lubricant Spray P 240 SPECIAL		246	<b>SPRAY LACAGEM P500 E PINCEL DE RETOQUE</b> / Spray for Lacquered Aluminium P 500 And Touch Up Pencil		260
<b>SPRAY LUBRIFICANTE P230</b> / Spray on Grease P 230 PREMIUM		246	<b>SPRAY TINTA ACRÍLICA</b> / Acrylic Enamel Spray		261
<b>SPRAY LUBRIFICANTE CORRENTES P180</b> / Chain and Rope Lubricant Spray P 180		247	<b>SPRAY ALTAS TEMPERATURAS</b> / High Temperature Enamel Spray		262



**CORTE**

Cut / Coupe / Corte

SDS PLUS <i>/ SDS Plus</i>		266 - 267
GUILHO SDS PLUS <i>/ Chisels SDS Plus Shank</i>		267
SDS MAX PREMIUM <i>/ SDS Max PREMIUM</i>		269
BROCA CRANEANA SDS MAX <i>/ Hollow Core Bit - SDS Max Adapter</i>		269
BROCA PERFURADORA SDS MAX <i>/ SDS Max Breakthrough Core Cutter</i>		270
GUILHO SDS MAX <i>/ Chisels SDS Max Shank</i>		270
BROCA ENCAIXE CILÍNDRICO MULTI MATERIAIS PREMIUM <i>/ Multi Construction Multi-Purpose Drill Bit Premium</i>		271
BROCA ENCAIXE CILÍNDRICO PARA GRÉS E PORCELANATO <i>/ Rotary Drill Bit for Hard Building Materials</i>		271
BROCA HSS DIN 338 <i>/ Twist Drills HSS DIN 338</i>		272 - 273
BROCA ESCALONADA <i>/ Step Drill Bits</i>		275
BROCA CRANEANA HSS <i>/ Hole Saws</i>		276
BROCA CRANEANA HSS PARA COLUNA MAGNÉTICA <i>/ HSS Core Drills for Magnetic Drilling Machines</i>		277
MACHOS E CAÇONETES <i>/ TAP and Round Dies</i>		278
FRESAS EM HSS PARA ALUMÍNIO <i>/ HSS Hole Saws</i>		279
CORTA CÍRCULOS AJUSTÁVEL PARA GESSO <i>/ Adjustable Hole Cutter</i>		279
FOLHA DE SERRA BIMETÁLICA <i>/ Bi-Metal Hacksaw Blades</i>		279
FITA DE SERRA E TICO-TICO <i>/ Multi-purpose Band Saw Blade and Jig Saw Blades</i>		280 - 281
DISCOS TCT <i>/ TCT Saw Blades</i>		282 - 283
ESCOVAS (CATRABUCHAS) <i>/ Cup and Wheel Brushes</i>		284



**DISCOS ABRASIVOS E POLIMENTO**

Abrasive Discs and Polishing / Disques Abrasifs et Polissage / Discos Abrasivos y Pulido

DISCOS CORTE <i>/ Cutting Discs</i>		287 - 289
DISCOS LAMELAS <i>/ Flap Discs</i>		290 - 292
DISCOS LIXA <i>/ Abrasive Discs</i>		293
ROLOS ABRASIVOS <i>/ Roller Abrasives</i>		294
BANDAS E CINTAS ABRASIVAS <i>/ Polishing Sleeves and Polishing Belts</i>		295 - 296
FOLHAS, ROLOS, BANDAS E CINTAS DE ESFREGÃO ABRASIVO <i>/ Nylon Abrasive Fleece and Polishing Sleeves for Expansion Roller and Polishing Belts</i>		296
REBOLOS ABRASIVOS <i>/ Mounted Non-Woven Wheels Abrasives and Mounted Flap Wheels Abrasive</i>		297
DISCOS NYLON <i>/ Nylon Clean Discs</i>		298



**DISCOS DIAMANTADOS**

Diamond Wheels / Disques Diamant / Discos Diamantados

DISCOS DIAMANTADOS LINHA SEGMENTADOS <i>/ Diamond Wheels - Segmented Line</i>		301
DISCOS DIAMANTADOS LINHA TURBO <i>/ Diamond Wheels - Turbo Line</i>		302
DISCOS DIAMANTADOS LINHA CERÂMICA <i>/ Diamond Wheels - Ceramics Line</i>		303

**DISCOS DIAMANTADOS  
LINHA PEDRA**  
/ Diamond Wheels - Stone Line



303

**DISCOS DIAMANTADOS  
LINHA PECOL MASTERCUT**  
/ Diamond Wheels PECOL MASTERCUT



305

**DISCOS DIAMANTADOS  
LINHA BETÃO E ASFALTO**  
/ Diamond Wheels - Concrete and Asphalt Line



306



**FERRAMENTA ELÉTRICA**

Power Tools / Outilage Électrique / Herramienta Eléctrica

**BERBEQUINS E APARAFUSADORAS M12**  
/ Percussion Drill and Compact Drill Driver M12



308 - 310

**BERBEQUINS E APARAFUSADORAS M18**  
/ Percussion Drill and Compact Drill Driver M18



312 - 316

**ILUMINAÇÃO M18**  
/ Lighting M18



316

**MARTELOS M18**  
/ Hammers M18



314

**MARTELOS COMBINADOS**  
/ Drilling and Breaking Hammer



317

**MARTELOS DEMOLIDORES**  
/ Breaking Hammer



317

**MÁQUINAS ELÉTRICAS**  
/ Electric Machines



318 - 319

**SERRAS ELÉTRICAS**  
/ Electric Saw



320

**REBARBADORAS**  
/ Angle Grinder



321 - 322

**TICK**



323

**RASO**



324



**SOLDADURA**

Welding / Soudure / Soldadura

**ELÉTODOS**  
/ Electrode



328 - 329

**VARETAS TIG**  
/ Varillas TIG



329

**FIO DE SOLDA**  
/ Solid Wire



330

**INVERSORES**  
/ Inverter



331

**MIGMAG**



332

**PISTOLAS MIG/MAG, TOCHAS TIG E  
ACESSÓRIOS**  
/ MIG/MAG Welding Torches, Torches TIG and  
Accessories



333 - 334

**EQUIPAMENTO DE  
PROTEÇÃO INDIVIDUAL**  
/ Personal Protective Equipment



335

**MAÇARICOS**  
/ Blowtorches



336 - 338



**PROTEÇÃO E SEGURANÇA**

Safety and Security / Protection et Sécurité / Protección y Seguridad

**PROTEÇÃO DOS PÉS**  
/ Foot Protection



340 - 341

**PROTEÇÃO DAS MÃOS**  
/ Hand Protection



342 - 343

**PROTEÇÃO DO CORPO**  
/ Body Protection



344 - 345

**PROTEÇÃO DA CABEÇA**  
/ Head Protection



346

**CINTAS DE CARGA E  
ARNÊS DE SEGURANÇA**  
/ Slings and Ratchet and Safety Harness



346

**PRODUTOS DE LIMPEZA**  
/ Hand cleaners



347



Consulte a restante gama de  
**PROTEÇÃO E SEGURANÇA**

/ Check the entire collection / Vérifiez toute la collection  
/ Compruebe toda la colección



**FERRAMENTA MANUAL**  
Hand Tools / Outillage Manuel / Herramienta Manual

CHAVES DE APERTO <i>/ Wrenches</i>		350 - 355
MARTELOS <i>/ Hammers</i>		355
ALICATES <i>/ Pliers</i>		356 - 357
CARROS E MALAS DE FERRAMENTAS <i>/ Trolleys and Tool Cases</i>		358
BITS <i>/ Bits</i>		360 - 364
CHAVES MAGNÉTICAS <i>/ Magnetic Nut Setter</i>		365
MEDIÇÃO <i>/ Measuring</i>		366 - 368
ALICATES DE REBITAR <i>/ Riveting Pliers</i>		369
CORTE <i>/ Cut</i>		370
GRAMPOS <i>/ Clamps</i>		371
CAIXAS DE FERRAMENTAS <i>/ Tool Boxes</i>		372
MATERIAIS DE CONSTRUÇÃO <i>/ Construction Tools</i>		373 - 376
GAMA DE PINTURA <i>/ Painting Range</i>		376 - 380

**MALAS DE FERRAMENTA**  
*/ Tool Cases*



385

**ESCADAS E ESCADOTES DE ALUMÍNIO**  
*/ Aluminum Ladder*



386

**CORRENTES E CABOS DE AÇO**  
*/ Chains and Steel Cables*



387 - 388

**TERMINAIS**  
*/ Terminals*



389



**CADEADOS**  
*/ Padlocks*



390



**FERRAGENS**  
*Furniture Hardware / Quincaillerie du Meuble / Herrajes*

DOBRADIÇAS <i>/ Hinge</i>		392
CORREDIÇAS <i>/ Slides</i>		393 - 394
GAVETA E KIT GAVETA G-STARK SLIM <i>/ Drawer and Drawer KIT G-STARK SLIM</i>		395
NIVELADORES <i>/ Hanging Brackets</i>		396 - 397
AMORTECEDORES + FECHOS TIC-TAC <i>/ Buffers + Push to Open</i>		398
LAMELLO <i>/ Lamello</i>		399 - 400
CABINEO		400
MINIMAG <i>/ MINIMAG</i>		400
ROUPEIROS <i>/ Wardrobes</i>		401
ACESSÓRIOS <i>/ Accessories</i>		402 - 404



**MANUTENÇÃO E ORGANIZAÇÃO**  
Maintenance and Organization / Maintenance et Organisation / Mantenimiento y Organización

PROJETORES DE TRABALHO <i>/ Energy Saves Work Light</i>		382
EXTENSÕES ELÉTRICAS <i>/ Cable Reel</i>		383
ROLOS DE PAPEL E SUPORTES <i>/ Industrial Paper Rolls and Supports</i>		383
RASO		384



**GESSO CARTONADO**  
Drywall / Plaques de Plâtre / Yeso Laminado

PCL 750 ZN		406
ALICATE PCL750 / Installation Plier		406
PCL 504 ZK		407
PCL 504 PA		407
PCL 508 PA		407
PCL 623 PA		407
PCL 622 ZN+PA		408
PCL 518 PA		408
PCL 700 L		409
PCL 755 ZN		409
PCL 762 ZN		409 - 410
PCL 203 PH		410
DIN 7504-N ZN		410
DIN 6334 ZN		410
DIN 934 ZN		411
DIN 975 ZN		411
ABRACADEIRA CURVA - U E L / Fixing Clamp with M6 Nut - L and Fixing Clamp with M6 Nut - U		411
CORREDEIRA M6 C/ FURO / Slide M6 with hole		412
EMENDA PARA PERFIL / Amendment to profile		412
PIVOT PARA PERFIL / Pivot for profile		412

**ESPÁTULAS DE CONSTRUÇÃO**  
/ Construction Spatulas

PCL 3018		412
DISCOS CORTE FINO AÇO INOX PREMIUM / Flat Cutting Thin Wheels Premium - Stainless Steel		413
SELANTE ACRÍLICO / Acrylic Sealant		413
ARAME / Padlocks		413
FITA PARA FISSURA / Fiber Glass Mesh		414
FITA PARA GESSO CARTONADO / Drywall Joint Paper Tape		414
FITA REFORCADA PARA CANTOS / Metal Corner Drywall Tape		414



MATERIAIS DO PRODUTO | Materiales de producto | Materiales de producto | Materiales de Producto

<b>A</b> Aço Steel Acier Acero	<b>A2 INOX</b> Bi-metal Bimetal Bimétal Bimetal	<b>A2 INOX</b> Aço Inox A2 Stainless steel A2 Inoxydable A2 Inoxidable A2	<b>A4 INOX</b> Aço Inox A4 Stainless steel A4 Inoxydable A4 Inoxidable A4	<b>Fe</b> Ferro Iron Fer Hierro	<b>Ni</b> Niquelado Nickel Plated Nickel Niquelado
<b>Zk</b> Zamak Zamak Zamak Zamak	<b>L</b> Latão Brass Laiton Latón	<b>PA</b> Poliamida Polyamide Polyamide Polyamide	<b>PP</b> Polipropileno Polypropylene Polypropylène Polipropileno	<b>PE</b> Polietileno Polyethylene Polyéthylène Polietileno	<b>GEO</b> Geomat Geomat Geomat Geomat
<b>PA YELLOW</b> Passivado Amarelo Yellow zinc-plated Bichromaté Bicromatado	<b>Cr</b> Cromado Chromed Chromé Cromado	<b>SR</b> Silver Ruspert Silver Ruspert Silver Ruspert Silver Ruspert	<b>BR</b> Blue Ruspert Blue Ruspert Blue Ruspert Blue Ruspert	<b>Z ZINC</b> Zincado Zinc-plated Zingué Zincado	<b>DAC</b> Dacromet Dacromet Dacromet Dacromet
<b>Z ZINC</b> Zincado negro Black zinc-plated Zingué noir Zincado negro	<b>AZ</b> Aço + Zinco Sherardizing Sherardizing Sherardizing	<b>PVC</b> PVC PVC PVC PVC	<b>PH</b> Fosfatado Phosphated Fosfaté Fosfatado	<b>G</b> Galvanizado Galvanized Galvanisé Galvanizado	<b>Ox</b> Oxidado Oxidized Rouillé Oxidado
<b>Cu</b> Cobre Copper Cuivre Cobre	<b>Al</b> Alumínio Aluminium Aluminium Aluminio	<b>P BLACK</b> Plástico Preto Plastic Black Plastique Noir Plastificado Negro	<b>Co Ti</b> Cobalto e Titânio (Co+Ti) Cobalt and Titanium Cobalt et Titane Cobalto y Titanio	<b>SAG</b> SAG SAG SAG SAG	

CARGAS | Loads | Charges | Cargas

<b>Cargas ligeiras</b> Light loads Charges faibles Cargas ligeras	<b>Cargas médias</b> Medium loads Charges moyennes Cargas medias	<b>Cargas Médias-altas</b> Medium-Heavy loads Charges moyennes-élevés Cargas Medias-altas	<b>Cargas pesadas</b> Heavy loads Charges élevés Cargas altas	<b>Cargas extra pesadas</b> Extra-heavy loads Charges lourdes Cargas grandes
--	---	--	--	---

MATERIAIS DE USO | Use materials | Matériaux d'utilisation | Materiales de uso

<b>Aço</b> Steel Acier Acero	<b>Aço Ligado</b> Alloy Steel Acier Allié Acero Aleado	<b>Aço não Ligado</b> Non-Alloy Steel Acier Non Allié Acero no Aleado	<b>Alumínio Lacado</b> Laquered Aluminium Aluminium Laqué Aluminio Lacado	<b>Azulejo</b> Tile Tuile Azulejo
<b>Cabos</b> Cable Câble Cable	<b>Carpintaria Alumínio</b> Aluminium Frames Menuiserie Aluminium Carpintería Alumínio	<b>Cerâmica</b> Ceramics Céramique Cerámica	<b>Cerâmica Sanitária</b> Sanitary Ceramics Céramique Sanitaire Cerámica Sanitária	<b>Chapa</b> Sheet Tôle Chapa
<b>Chapa Fina</b> Thin Sheet Feuille Tôle Chapa Fina	<b>Chapa Inox</b> Stainless Steel Sheet Inoxydable Tôle Chapa Inoxidable	<b>Cromado</b> Chrome Chromé Cromado	<b>Cobre</b> Cooper Cuivre Cobre	<b>Estuque</b> Plaster Plâtre Escayola
<b>Ferro/ Aço</b> Iron/ Steel Fer/ Acier Hierro/ Acero	<b>Fibrocimento</b> Fibrement Fibre-ciment Fibrocemento	<b>Ferro Fundido Cinzento</b> Gray Cast Iron Fonte Grise Fundición Gris	<b>Fundição Maleável</b> Malleable Cast Irons Fonte Malléable Fundición Maleable	<b>Betão Reforçado</b> Reinforced Concrete Béton Armé Hormigón Armado
<b>Betão Areado</b> Areated Concrete Béton Cellulaire Hormigón Celular	<b>Betão Fissurado</b> Cracked Concrete Béton Fissuré Hormigón Fisurado	<b>Betão não Fissurado</b> Uncracked Concrete Béton non Fissuré Hormigón no Fisurado	<b>Betão Oco</b> Hollow Concrete Béton Creuse Hormigón Hueco	<b>Tubo Aço Inoxidável</b> Stainless Steel Pipe Tube Acier Inoxydable Tubo Inoxidable
<b>Aço Inoxidável</b> Stainless Steel Acier Inoxydable Inoxidable	<b>Lacado</b> Lacquered Laqué Lacado	<b>Tijolo Oco</b> Hollow Brick Brique Creuse Ladrillo Hueco	<b>Tijolo Maciço</b> Solid Brick Brique Pleine Ladrillo Macizo	<b>Madeira</b> Wood Bois Madera
<b>Metal Sinterizado</b> Sintered metal Métal fritté Metal Sinterizado	<b>Metais não Ferrosos</b> Non-ferrous metal Métaux non ferreux Metal no Ferroso	<b>Painel Sandwich</b> Sandwich Panel Panneau Sandwich Panel Sandwich	<b>Plástico</b> Plastic Plastique Plástico	<b>Perfis &gt; 6mm</b> Profiles Profils Perfiles
<b>Pedra</b> Stone Pierre Piedra	<b>Gesso Laminado</b> Plasterboard Placo-Prâtre Placa Yeso Laminado	<b>Plástico</b> Plastic Plastique Plástico	<b>Poliestireno Expandido</b> Expanded Polystyrene Polystyrène Expansé Poliestireno Expandido	<b>PVC</b> PVC PVC PVC
<b>Argila Areada</b> Honeycomb Clay Block Briques de Terre Cuite Termaorcilla	<b>Tubo Flexível</b> Flexible Pipe Tube Flexible Tubo Flexible	<b>Tubo Gás</b> Gas Pipe Tube Ggaz Tubo Gas	<b>Tubo PVC</b> PVC Pipe Tube PVC Tubo PVC	<b>Tubo Incêndios</b> Fire Fighting Pipe Tuyaus Incendies Tubo de Incendios
<b>Tubos Escape</b> Exhausts Échappement Tubo Escape	<b>Tubos de Ventilação</b> Ventilation Ventilation Tubos Ventilación	<b>Telha</b> Tile Tuile Teja	<b>Vidro</b> Glass Verre Vidrio	

OUTROS | Other | Autre | Otros

<b>Resistente aos raios U.V.</b> Resistant to U.V. Résistant aux rayons U.V. Resistente los rayos U.V.	<b>Fortes propriedades anti fungos</b> High fungal resistant Fortes propriétés antifongiques Fuerte acción fungicida	<b>Agarre inicial forte</b> Strong initial grabin Prise initiale fort Agarre inicial fuerte	<b>Rendimento aproximado de 45 litros</b> Yield approx to 45 liters Rendement approximatif de 45 litres Rendimiento aproximado a 45 litros	<b>Fibras</b> Fibers Fibres Fibras
<b>Pode ser pintado</b> Can be painted Peut être peint Puede ser pintado	<b>Resistente a temperaturas</b> Flexible at temperatures Flexible a températures Flexible a temperaturas	<b>Secagem rápida</b> Fast drying Séchage rapide Secado rápido	<b>Resistente à humidade</b> Resistant to humidity Résistant à l'humidité Resistente a la humedad	<b>Fixação extra forte</b> Extra strong grab Fixation extra fort Extra fuerte
<b>Inodoro</b> Odorless Inodore Inodoro	<b>Interiores e exteriores</b> Indoors and outdoors Intérieures en extérieurs Exterior en interior	<b>Interiores</b> Indoors Intérieures Interior	<b>Testado para uso em betão fissurado</b> Tested for use in cracked concrete Testé pour dans le béton fissuré Probado para uso en hormigón fissurado	
<b>Boa resistência à água</b> Good resistance to water Bonne résistance à l'eau Buena resistencia al agua	<b>Excelente adesão</b> Very good adhesion Excellente adhesion Excelente adhesión	<b>Sem pregos</b> No nails Sans clous Sin clavos	<b>Testado p/ uso condições sísmicas - C1</b> Tested for use in seismic conditions - C1 Testé pour utilization en sismiques conditions - C1 Probado para uso en condiciones sísmicas C1	
<b>Libre de Solventes</b> Solvent-free Sans Solvants Libre de Solventes	<b>Grande poder de adesão</b> Very good adhesion Grand pouvoir de accession Gran poder de adhesión	<b>Flexível</b> Flexible Flexible Flexible	<b>Pode ser aplicado em superfícies húmidas</b> Can be applied to damp surfaces Peut être appliqué sur des surfaces humides Puede ser aplicado en superficies húmedas	

The background of the advertisement is a dark, textured surface. Scattered across it are various tools and hardware: a blue adjustable wrench at the top, a grey power drill bit, a long metal bolt with a hex nut, a shorter metal bolt with a hex nut, a grey power drill, and a grey hex nut. The text is overlaid on this background.

# SEGMENTOS DE ATIVIDADE

MARKET SEGMENT  
SEGMENTS D'ACTIVITÉ  
SEGMENTOS DE ACTIVIDAD



# SOLUÇÕES GLOBAIS DE FIXAÇÃO

Global Fixing Solutions / Solutions de Fixation / Soluciones Globales de Fijación

003000500012



006005000000



00210...



002700...



001903050150



002602000000



002000000...



00720002...



0030000...



0303210...

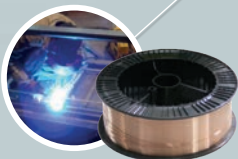

009126...



0000113255...



003000500001



001001000000

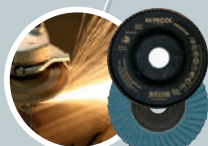

0075141...



00100800000...



005904000000



002402000000



002803000000



0020000000...







006003000000



976022...



00300002200...



0040010...



0030005000...



00350...



0753231...



001020000000



001029000000



034150...



001050000000



003200000042

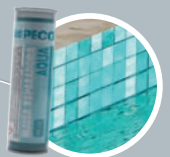

00301150000...



002109...

00290...



0042011...



001006000000



005804000001



00580100000...



00830505...



020222...

# SERRALHARIA DE ALUMÍNIO

Aluminium Frame Industry / Serrurerie d'Aluminium / Carpintería de Aluminio

**PECOL®**  
Sistemas de Fixação



## ESPUMA POLIURETANO B2/B3

PU Foam B2/B3 Premium / Mousse  
Polyuréthane B2/B3 / Espuma Poliuretano  
B2/B3

## BROCAS SDS PLUS

SDS Plus Hammer Drill  
/ Foret à Marteau SDS Plus  
/ Brocas SDS Plus



## PARAFUSOS AGL

Chipboard screws  
/ Vis pour aggloméré  
/ Tirafundo

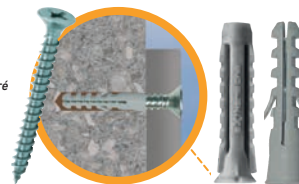

## BUCHA NYLON PCL500 E PCL518

Nylon plug PCL500 and PCL518  
/ Chevilles plastiques PCL500 et  
PCL518 / Anclajes Plásticos PCL500  
y PCL518



## PARAFUSOS AUTO-ROSCANTES

Self Tapping Screws / Vis à Tôle / Tornillos  
Autorroscantes

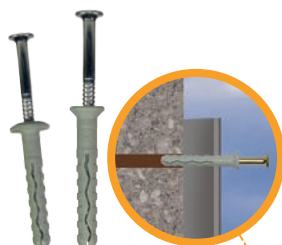

## BUCHA TAP-TIP

Hammer in Polyamide Plug / Cheville à  
Frapper / Taco Clavable TAP-TIP



## FRESA HSS ALUMÍNIO

HSS Hole Saws / Trépan HSS M2  
/ Broca Corona HSS M2 metal

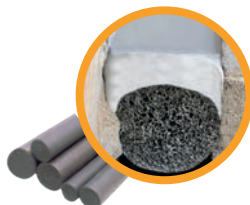

## CORDÃO P/ JUNTAS DE DILATAÇÃO PE

Polyethylene (PE) Cord / Cordon p/ Joints de  
Dilatation PE / Cordón p/ Juntas de Dilatación PE



## SILICONE NEUTRO E ACETATO

Neutral and Acetoxysilicone / Silicone Neutre  
et Acétique / Silicona Neutra y Acetato



## FERRAMENTA MANUAL

Hand Tools / Outillage Manuel / Herramienta Manual



## BROCAS HSS DIN 338

Twist Drills HSS DIN 338 / Forets  
HSS DIN 338 / Brocas HSS DIN 338



## PARAFUSOS AUTOPERFORANTES

Self Drilling Screws / Vis  
Autoperceuse / Tornillos  
Autotaladrantes

## EQUIPAMENTO DE PROTEÇÃO INDIVIDUAL

Personal protective equipment / Équipement de protection individuelle / Equipos de protección individual



### COLA CIANOACRILATO PECOL P1 PEN-SYSTEM

Contact Cyanoacrylate Adhesive Pecol - P1 Pen-System / Colle Cyanoacrylate Pecol P1 Pen-System / Adhesivo Cianocrilato Pecol P1 Pen-System

### MASSA PARA JUNTAS DE ALUMÍNIO E PVC P250

Aluminium and PVC Bonding and Sealing Glue / Pâte à Joints pour Aluminium et PVC P 250 / Masilla para Juntas de Aluminio y PVC P 250

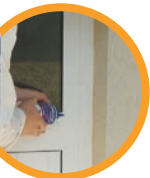

### PELÍCULA PROTETORA INVISÍVEL PARA VIDRO

Invisible Glass Protective Film / Film de Protection Invisible pour le Verre / Película Protectora Invisible para Vidrio



### SPRAY LACAGEM P 500 E PINCEL DE RETOQUE

Spray for Lacquered Aluminium P 500 And Touch Up Pencil / Spray Laquage P 500 et Pinceau de Retouche / Spray Lacado P 500 y Pincel de Retoque



### DISCOS CORTE FINO

Flat Cutting Thin Wheels / Meules à Tronçonner fines / Discos Corte Fino

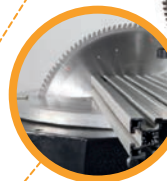

### DISCOS TCT ALUMÍNIO E PLÁSTICO

TCT Saw Blades (Aluminium and Plastic) / Lames de Scie Circulaire (Aluminium et Plastique) / Discos Widia (Aluminio y Plástico)



### IMPERMEABILIZANTE LÍQUIDO

Waterproofing Liquid / Produit d'étanchéité liquide / Impermeabilizante Líquido



### DISCOS DIAMANTADOS

Diamond Wheels / Disques Diamant / Discos Diamantados



### REBARBADORA

Angle Grinder / Meuleuse / Amoladora Angular

### PARAFUSOS PVC PCL 225 E 226

PCL 225 and PCL 226 PVC Screws / PCL 225 et PCL 226 Vis PVC / PCL255 y PCL 226 Tornillos de PVC



### SPRAY ALUMÍNIO P 40 PREMIUM

Aluminium Spray P 40 Premium / Spray Aluminium P 40 Premium / Spray Aluminio P40 Premium



VEDANTE MSP E COLA E VEDA  
MSP sealant and Polyurethane sealant Cola & Veda / Mastic MSP et Mastic PU / Sellador MSP y Pega y sella



SPRAY TURBO P 50 PREMIUM  
Spray Turbo P 50 Premium / Spray Turbo P 50 Premium / Spray Turbo P 50 Premium



### SPRAY LIMPEZA DE VIDRO E ALUMÍNIO P120

Glass and Aluminium Spray Cleaner P 120 / Spray Nettoyant de Vitre et Aluminium P 120 / Spray Limpieza de Vidrio y Aluminio P 120



### VEDANTE PELÚCIA

Weatherstrips / Joint Brosse / Burtete de Felpa



# SERRALHARIA DE FERRO

Metal Industry / Serrurerie – Ferronnerie d'art / Carpintería de Hierro

**PECOL®**  
Sistemas de Fixação

## MASSA REPARADORA AÇO

Steel Epoxy Putty Sticks / Pâte Réparatrice Epoxy en Tube / Masilla Reparadora Acero



## BUCHA PCL 784 E PCL 764

Metal anchors PCL784 and PCL764 / Chevilles métalliques PCL784 et PCL764 / Anclajes metálicos PCL784 y PCL764

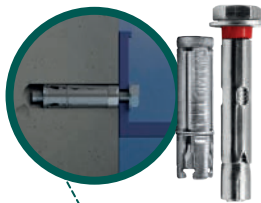

## SPRAY ZINCO

Zinc Spray / Spray Zinc / Spray Zinc



## PARAFUSOS AUTOPERFORANTES

Self Drilling Screws / Vis Auto-perceuse / Tornillos Autotadrantes



## DISCOS DE LAMELAS TORNADO

Flap Disc Tornado Premium / Disque à Lamelles Tornado Premium / Discos de Láminas Tornado Premium



1KG  
20 min



## REBARBADORA

Angle Grinder / Meuleuse / Amoladora Angular



## DISCOS DIAMANTADOS

Diamond Wheels / Disques Diamant / Discos Diamantados



## DISCOS CORTE FINO E REBARBAR

Flat Cutting Thin Wheels and Grinding Wheels / Meules à Tronçonner fines et Meule à Ébarber / Discos Corte Fino y Discos de Desbaste

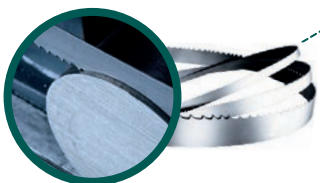

## FITA DE SERRA BIMETÁLICA M42

Multi-purpose Band Saw Blade M42 / Lame de Scie à Ruban Bimétallique M42 / Hoja de Sierra Bimetálica M42



## FERRAMENTA MANUAL

Hand Tools / Outillage Manuel / Herramienta Manual

## BUCHA NYLON PCL500

Nylon plug PCL500 / Chevilles plastiques PCL500 / Anclajes Plásticos PCL500

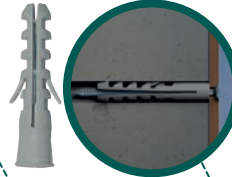

## DISCOS DE LIXA ÓXIDO ALUMÍNIO

Flexible Fibre Discs Aluminium Oxide / Disque Abrasif Oxide d'Aluminium / Disco de Lija Óxido Alumínio



## BROCAS SDS PLUS

SDS Plus Hammer Drill / Foret à Marteau SDS Plus / Brocas SDS Plus



## SPRAY TINTA ACRÍLICA

Acrylic Enamel Spray / Spray Peinture Acrylique / Spray Pintura Acrílica



## CHUMBADORES (OLHAL COM FIEL MONTADO)

Hinge with Stud Mounted / Paumelle (Oeillet avec Tige en Fer Montée) / Bisagra c/ Pasador de Hierro Montado

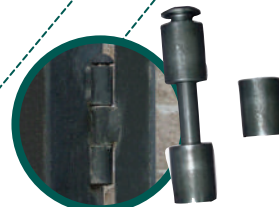

## SPRAY LUBRIFICANTE P 230 PREMIUM

Spray on Grease P 230 Premium / Spray Lubrifiant P 230 Premium / Spray Lubricante P 230 Premium



## EQUIPAMENTO DE PROTEÇÃO INDIVIDUAL

Personal protective equipment / Équipement de protection individuelle / Equipos de protección individual

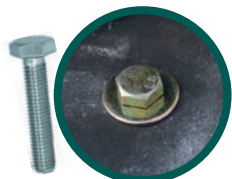

**PARAFUSOS SEXTAVADOS**  
Hexagonal Bolts / Vis a Tête Hexagonal / Tornillos Cabeza Hexagonal



**FOLHA DE SERRA BIMETÁLICA**  
Bi-Metal Hacksaw Blades / Lame de Scie Bimétallique / Hoja de Sierra Bimetálica

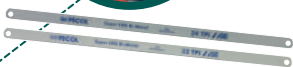

**SILICONE**  
Silicone / Silicone / Silicona



**GRAMPO DE APERTO**  
Quick Clamp / Serre-Joint / Sargento de Apriete

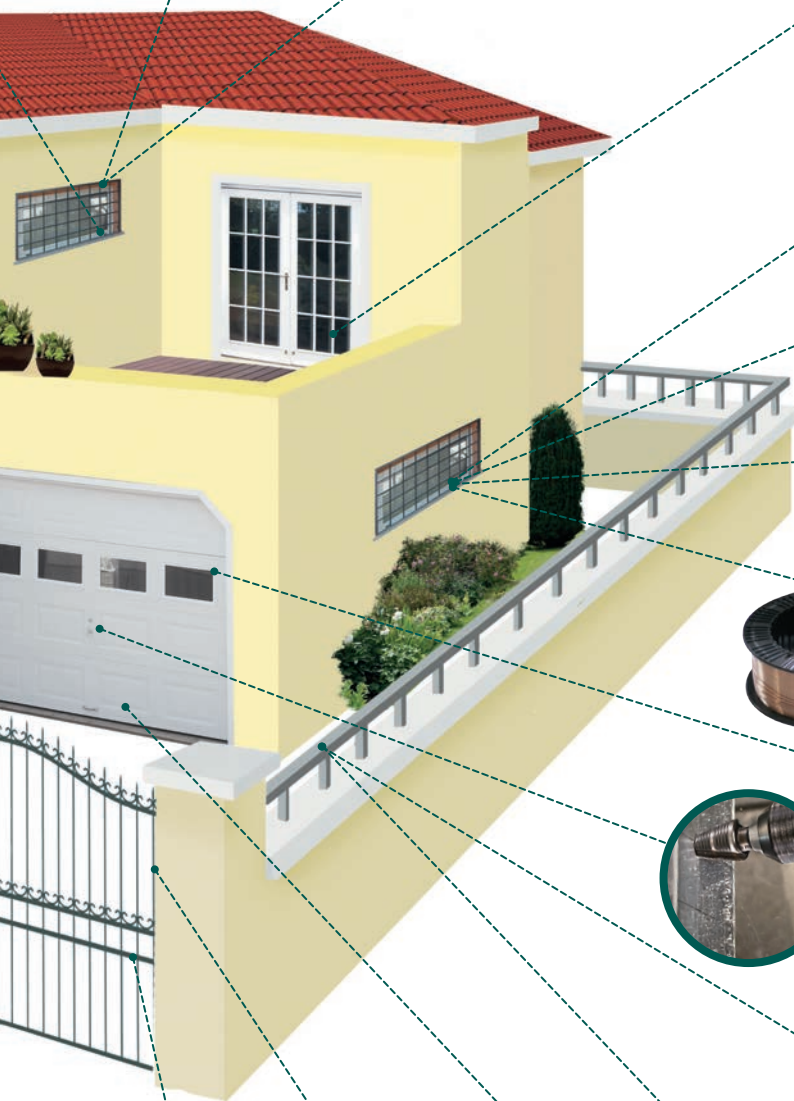
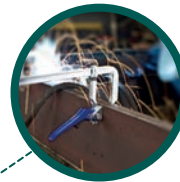

**SPRAY PROTETOR DE SOLDADURA P60**  
Welding Protection Spray P 60 / Spray Protecteur de Soudure P60 / Spray Protetor de Soldadura P60



**INVERSOR**  
Inverter / Inverseur / Inversor

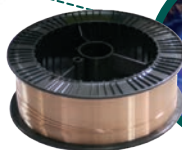

**SOLDADURA**  
Welding / Soudure / Soldadura

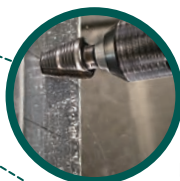

**BROCA ESCALONADA**  
Step Drill Bits / Fraises Étagées / Brocas Escalonadas



**VEDANTE MSP E COLA E VEDA**  
MSP sealant and Polyurethane sealant Cola & Veda / Mastic MSP et Mastic PU / Sellador MSP y Pega y sella

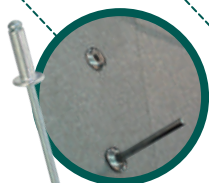

**REBITES**  
Blind rivets / Rivets / Remaches



**SPRAY TURBO P 50 PREMIUM**  
Spray Turbo P 50 Premium / Spray Turbo P 50 Premium / Spray Turbo P 50 Premium



**BUCHA QUÍMICA VINÍLICA**  
Chemical Anchor / Mortier de Scellement Chimique / Taco Químico



**BROCAS HSS DIN 338**  
Twist Drills HSS DIN 338 / Forets HSS DIN 338 / Brocas HSS DIN 338



**SPRAY ÓLEO CORTE E FURAR P220**  
Cutting Oil Spray P 220 / Spray Huile Couper et Percer P 220 / Spray Aceite Corte y Perforado P 220

# SERRALHARIA DE INOX

Stainless Steel Industry / Serrurerie Inox / Carpintería de Inoxidable

## SPRAY PROTEÇÃO E LIMPEZA DE AÇO INOX P 70

Stainless Steel Care Spray P 70 / Spray de Protection et Nettoyage d'Acier Inox P 70 / Spray Protección y Limpieza de Acero Inox P 70



## VEDANTE MSP E COLA E VEDA

MSP sealant and Polyurethane sealant Cola e Veda / Mastic MSP et Mastic PU / Sellador MSP y Pega y sella



## SILICONE NEUTRO E ACETATO

Neutral and Acetoxy Silicone / Silicone Neutre et Acétique / Silicona Neutra y Acetato

## SPRAY INOX P 30 PREMIUM

Stainless Steel Spray P 30 Premium / Spray Inox P 30 Premium / Spray Inox P 30 Premium



## SPRAY LUBRIFICANTE SECO PTFE P 140

PTFE Dry Lube Spray P 140 / Spray Lubrifiant sec PTFE P 140 / Spray Lubrificante seco PTFE P 140



A2  
308 AISI  
A4  
316 AISI  
2h

## DISCOS DE LAMELAS LONG LIFE PREMIUM

Flap Disc Long Life Premium / Disque à Lamelles Long Life Premium / Discos De Láminas Long Life Premium

## REBARBADORA

Angle Grinder / Meuleuse / Amoladora Angular

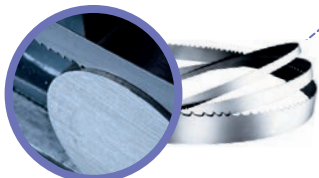

## FITA DE SERRA BIMETÁLICA M42

Multi-purpose Band Saw Blade M42 / Lame de Scie à Ruban Bimétallique M42 / Hoja de Sierra Bimetallica M42



## DISCOS CORTE FINO

Flat Cutting Thin Wheels / Meules à Tronçonner fines / Discos Corte Fino



## DISCOS DE LIXA ZIRCÓNIO

Flexible Fibre Discs Alumina Zirconia / Disque Abrasif Zircone / disco DE LIJA Zirconio

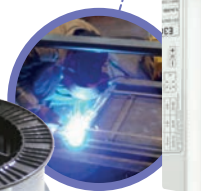
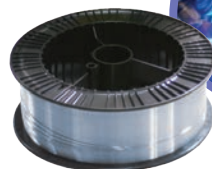

## SOLDADURA

Welding / Soudure / Soldadura



## VARETAS TIG PARA SOLDADURA EM AÇO INOX

TIG Rods for Stainless Steel TIG Welding / Baguettes TIG pour soudure en Acier Inox / Varillas TIG para soldadura en Acero Inox

## EQUIPAMENTO DE PROTEÇÃO INDIVIDUAL

Personal protective equipment / Équipement de protection individuelle / Equipos de protección individual



### POLIDORA DE ROLOS

Polishing Grinding Machine / Polisseuse à bandes / Pulidora de Rodillos



### ROLOS E CINTAS DE LIXA

Roller and Abrasive Belt / Roues et Bande Abrasive / Rodillos y Cintas de Lija

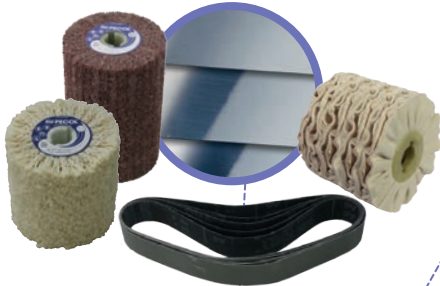

### POLIDORA DE CINTAS

Pipe Sniper / Ponceuse à Bandes / Pulidora de Cintas



### FERRAMENTA MANUAL

Hand Tools / Outillage Manuel / Herramienta Manual



### REBITE CABEÇA BOLEADA

Blind rivet / Rivet aveugle à tête plate / Ciego con cabeza alomada



### PARAFUSO AUTOPERFORANTE

Self Drilling Screws / Vis Autoperceuse / Tornillos Autotaladrantes



### BROCA ESCALONADA

Step Drill Bits / Fraises Étagées / Brocas Escalonadas

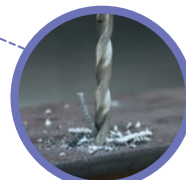

### BROCAS DE COBALTO 5% E 8%

Twist Drills HSS 5% and 8% Co / Forets HSS 5% et 8% Co / Brocas HSS 5% y 8% Co



### SPRAY PROTETOR DE SOLDADURA P60

Welding Protection Spray P 60 / Spray Protecteur de Soudure P60 / Spray Protetor de Soldadura P60



### SPRAY ÓLEO CORTE E FURAR P220

Cutting Oil Spray P 220 / Spray Huile Couper et Percer P 220 / Spray Aceite Corte y Perforado P 220



### INVERSOR T40.20 PAH

Inverter T40.20 PAH / Inverseur T40.20 PAH / Inversor T40.20 PAH



### SERRA CRANEANA BIMETÁLICA AISI M42 (HSS - CO 8%)

Bi-Metal Variable Pitch Hole Saw AISI M42 (HSS - Co 8%) / Scie Trépan Bimétallique AISI M42 (HSS - Co 8%) / Sierra Corona Bimetalica AISI M42 (HSS - Co 8%)

## FITA DE SERRA BIMETÁLICA M42

Multi-purpose Band Saw Blade M42  
/ Lame de Scie à Ruban Bimétallique M42  
/ Hoja de Sierra Bimetálica M42

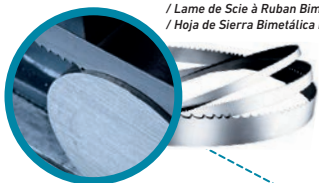

## DISCOS CORTE FINO

Flat Cutting Thin Wheels / Meutes à Tronçonner fines / Discos Corte Fino



## CHAVE DINAMOMÉTRICA

Torque Wrench  
/ Clé Dynamométrique  
/ Llave Dinamométrica



## PARAFUSOS SEXTAVADOS DIN 931 E 933

Hexagon head bolts DIN 931 and 933  
/ Vis à tête hexagonale 931 et 933  
/ Tornillería hexagonal 931 y 933



## REBARBADORA

Angle Grinder / Meuleuse  
/ Amoladora Angular



## DISCOS DE LAMELAS TORNADO

Flap Disc Tornado Premium  
/ Disque à Lamelles Tornado Premium  
/ Discos de Láminas Tornado Premium



1KG  
20 min

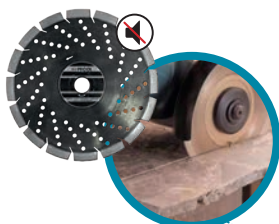

## DISCOS DIAMANTADOS

Diamond Wheels / Disques Diamant  
/ Discos Diamantados

## DISCOS DE LIXA ÓXIDO ALUMÍNIO

Flexible Fibre Discs Aluminium Oxide  
/ Disque Abrasif Oxyde d'Aluminium  
/ Disco de Lija Óxido Aluminio

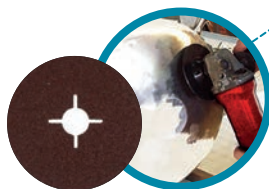

## FIO DE SOLDA SG2 E ELÉTRÓDOS RUTILO/BÁSICO

MIG MAG Solid Wire - SG2 and Rutile/Basic Coated Electrode  
/ Fil de Soudure SG2 et Electrodes Rutile/Basique  
/ Hilo de Soldadura SG2 y Electrodes Rutilo/Básico

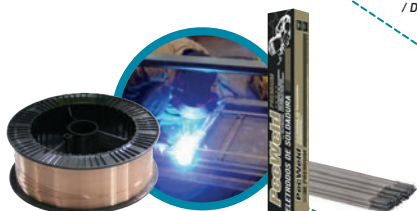

## SPRAY PROTETOR DE SOLDADURA P 60

Welding Protection Spray P 60  
/ Spray Protecteur de Soudure P60  
/ Spray Protector de Soldadura P60



## SPRAY ZINCO ESCURO P20

Zinc Spray Coating Dark Colour P20 / Spray Zinc Foncé P20 / Spray Zinc Oscuro P20



## BUCHA METÁLICA PCL753 E PCL764

Metal anchors PCL753 and PCL764  
/ Chevilles métalliques PCL753 et PCL764  
/ Anclajes metálicos PCL753 y PCL764

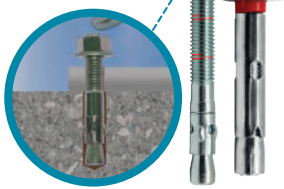

## BUCHA QUÍMICA

Chemical Anchor  
/ Mortier de Scellement Chimique / Taco Químico



## GUILHOS

Chisels / Burins / Cinceles





## EQUIPAMENTO DE PROTEÇÃO INDIVIDUAL

Personal protective equipment / Équipement de protection individuelle / Equipos de protección individual



### BROCA CRANEANA HSS P/ COLUNA MAGNÉTICA

HSS Core Drills for Magnetic Drilling Machines / Trépan Marteau HSS pour Colonne Magnétique / Broca Corona HSS para Columna Magnética



### COLUNA MAGNÉTICA

Magnetic Drilling Press / Colonne Magnétique / Soporte de Taladrar Magnético

### PARAFUSOS DE COBERTURA PCL 8972/8971

Screws For Decking PCL 8972/8971 / Vis Pour Toitures PCL 8972/8971 / Tornillos P/ Cubiertas PCL 8972/8971

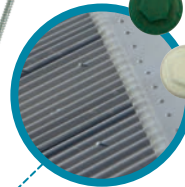

### CAPUCHON DE NYLON

Nylon Screw Cover / Capuchons en Nylon / Tapones de Nylon



### SPRAY ÓLEO CORTE E FURAR P220

Cutting Oil Spray P 220 / Spray Huile Couper et Percer P 220 / Spray Aceite Corte y Perforado P 220



### BROCA HSS DIN 338

Twist Drills HSS DIN 338 / Forets HSS DIN 338 / Brocas HSS DIN 338



### VEDANTE MSP E COLA E VEDA

MSP sealant and Polyurethane sealant Cola & Veda / Mastic MSP et Mastic PU / Sellador MSP y Pega y sella



### SPRAY TURBO P 50 PREMIUM

Spray Turbo P 50 Premium / Spray Turbo P 50 Premium / Spray Turbo P 50 Premium



### REBITE CABEÇA BOLEADA

Blind rivet / Rivet aveugle à tête plate / Ciego con cabeza alomada



### BROCAS SDS MAX

SDS Max Hammer Drill / Foret à Marteau SDS Max / Brocas SDS Max



### ESPUMA POLIURETANO B2/B3

PU Foam B2/B3 Premium / Mousse Polyuréthane B2/B3 / Espuma Poliuretano B2/B3

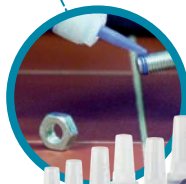

### PECLOCKS

Anaerobic Adhesives / Anaerobic Adhesives / PECLOCKS

### VARÃO DIN 975 E HASTE ROSCADA DIN 976

Threaded rod DIN 975 and Stud bolt DIN 976 / Tige filetée DIN 975 et Bouts Filetés DIN 976 / Varrilla roscado DIN 975 y Esparrago totalmente roscado DIN 976

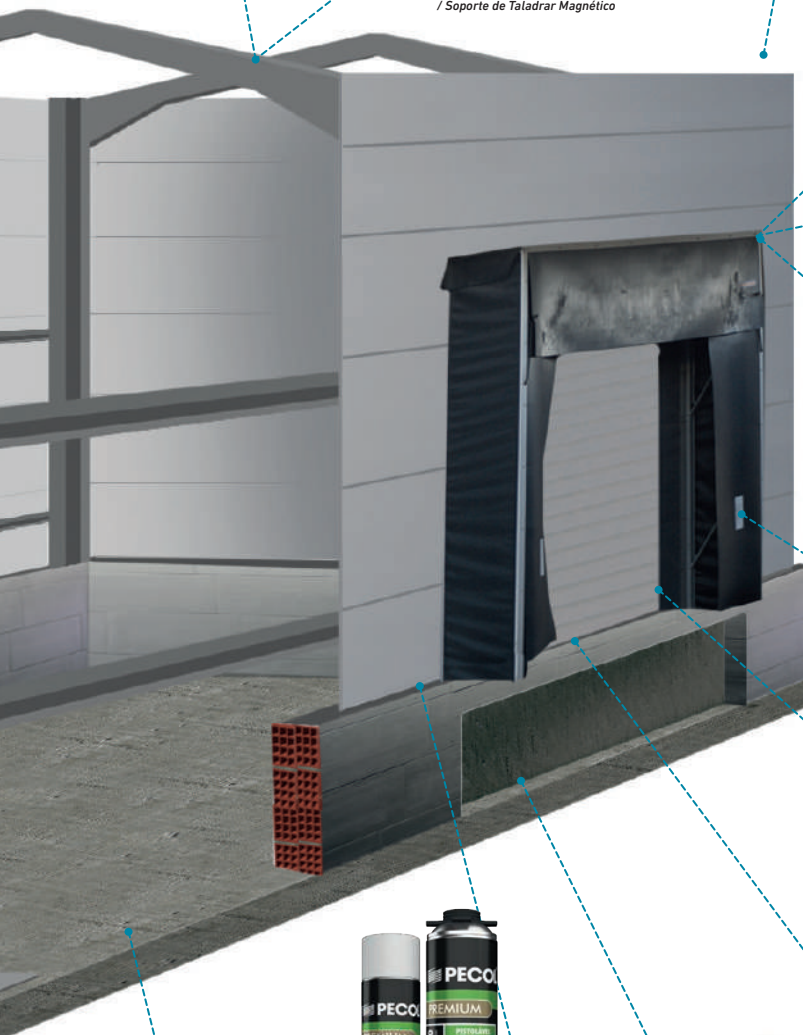

# GESSO E TETOS FALSOS

Drywall / Plaques de Plâtre / Yeso Laminado

**PECOL®**  
Sistemas de Fixação

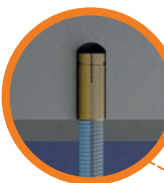

## BUCHA DE LATÃO PCL700

Brass Anchor  
/ Cheville en Laiton  
/ Taco de Latón



## BROCAS SDS PLUS

SDS Plus Hammer Drill  
/ Foret à Marteau SDS Plus  
/ Brocas SDS Plus

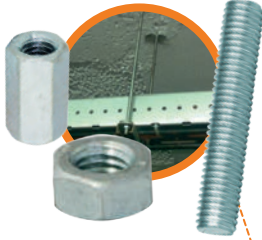

## VARÃO ROSCADO DIN 975

Threaded rod / Tige filetée / Varilla rosada

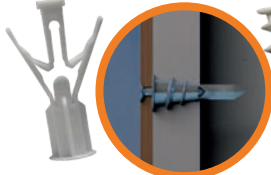

## BUCHA PARA GESSO PCL504/ PCL508

Self Drilling Dry Wall Plug PCL504/ PCL508  
/ Cheville pour Plâtre PCL504 / PC508  
/ Bucha para Gesso PCL504 / PCL508



## CORREDIÇA M6 COM FURO

Slide M6 with hole  
/ Slide M6 avec trou  
/ Slide M6 con agujero

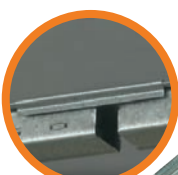

## EMENDA PARA PERFIL

Amendment to profile  
/ Amendement au profil  
/ Enmienda para perfil

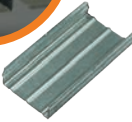

## ARAME

Wire / Fil / Alambre



## MÁSCARA COM FILTRO

Mask with Valve / Masque avec Valve  
/ Mascarilla c/ Válvula

## MISTURADOR + HASTE

Mixer / Électrique  
Mélangeur / Mezcladores

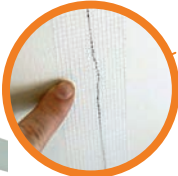

## FITA PARA FISSURAS

Fiber glass mesh / Bande à fissures  
/ Cinta para fissuras



## ESPÁTULAS

Spatulas / Spatules  
/ Espátulas



## BANDA DE GESSO

Drywall joint paper tape / Ruban de papier  
/ Cinta de papel



## FITA DE PINTURA + FILME E FITA DE PINTURA

Masking Tape + Film and Paper Masking Tape / Ruban de Peinture + Filme  
et Ruban de Peinture / Cinta de Pintor + Film y Cinta de Pintor



## BUCHA POLIAMIDA P/ GESSO PCL 623

Concrete Polyamide Nail-it Anchor PCL 623  
/ Cheville Polyamide p/ Plâtre PCL 623  
/ Taco Poliámidida p/ Yeso PCL 623



## FATO DESCARTÁVEL

Disposable Overall /  
Combinaison / Ropa  
desechable



## EQUIPAMENTO DE PROTEÇÃO INDIVIDUAL

Personal protective equipment / Équipement de protection individuelle / Equipos de protección individual



### ALICATE DE REBITAR BUCHAS 750

Installation plier / Pince à riveter cheville 750 / Alicata de remachar tacos 750

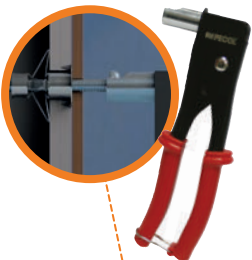

### BUCHA METÁLICA PCL750

Steel Anchor For Thin Hollow Walls PCL 750 / Cheville Métallique PCL 750 / Taco Metálico PCL 750

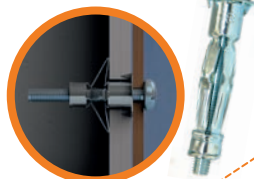

### MOLA BASCULANTE PCL 762 E 772

Spring Toggles PCL 762 and 772 / Cheville à Ressort PCL 762 et 772 / Anclaje Palomilla PCL 762 y 772



### CORTA CÍRCULOS AJUSTÁVEL P/ GESSO

Adjustable Hole Cutter / Scie cloche ajustable / Cortacirculos ajustable con recogepotvo



### SELANTE ACRÍLICO

Acrylic Sealant / Mastic Acrylique / Sellante Acrílico



### NÍVEL LASER DE LINHAS XL2

Line Lasers XL2 / Niveau Laser Lignes XL2 / Nivel Láser de Líneas XL2

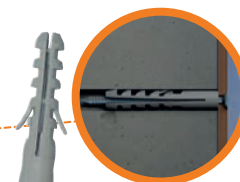

### BUCHA NYLON PCL500

Nylon plug PCL500 / Chevilles plastiques PCL500 / Anclajes Plásticos PCL500

### PARAFUSOS AUTOPERFORANTES CABEÇA SEXTAVADA PCL 9760

Hexagon flange head self drilling screw / Vis autoperceuse tête hexagonale à embase cylindrique / Tornillo autotaladrar de cabeza hexagonal con collarin

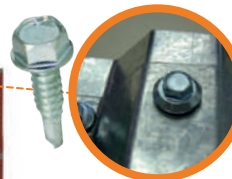

### PARAFUSOS AUTOPERFORANTES CABEÇA DE QUEIJO, PHILLIPS PCL 9810

Self-drilling screw with panhead, Phillips recess / Vis autoperceuse, pointe foreuse, tête cylindrique bombée, Phillips / Tornillo autotaladrante de cabeza alomada y huella Phillips



### PARAFUSOS AUTOPERFORANTES CABEÇA DE QUEIJO, PHILLIPS PCL 9810

Self-drilling screw with panhead, Phillips recess / Vis autoperceuse, pointe foreuse, tête cylindrique bombée, Phillips / Tornillo autotaladrante de cabeza alomada y huella Phillips



### DISCOS CORTE FINO

Flat Cutting Thin Wheels / Meules à Tronçonner fines / Discos Corte Fino



### FITA REFORÇADA PARA CANTOS

Metal corner drywall tape / Bandes de coins / Cinta de esquinas y rincones



### LIXADORA VIBRATÓRIA SPS140

Sheet Palm Sander SPS140 / Ponceuse Vibratoire SPS140 / Lijadora Orbital de Acabado SPS140



### APARAFUSADORA AFSE 500

Cordless Screwdriver AFSE500 / Visseuse p/ Phosphatés AFSE 500 / Atornillador para Tornillos fosfatados AFSE 500



### APARAFUSADORA P/ GESSO CARTONADO M18 FSGC

Drywall Screw Gun M18 FSGC / Visseuse plaquiste sans fil M18 FSGC / Atornillador cartón yeso M18 FSGC

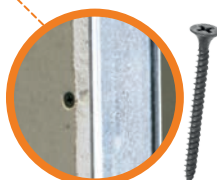

### PARAFUSO CABEÇA DE EMBEBER PHILLIPS FOSFATADO PCL203

Drywall screw for plasterboard, with bugle head, twinfast thread / Vis pour plaques de plâtre, tête trompette, double filet / Tornillo para placas de yeso laminado con cabeza trompeta, rosca doble hilo

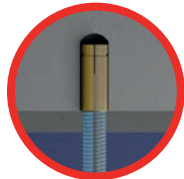

**BUCHA DE LATÃO PCL700**  
Brass Anchor / Cheville en Laiton  
/ Taco de Latón

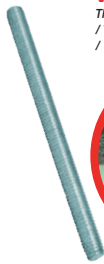

**VARÃO DIN 975**  
Threaded rod DIN 975  
/ Tige fileté DIN 975  
/ Varrilla rosado DIN 975



**BUCHA NYLON PCL500**  
Nylon plug PCL500  
/ Chevilles plastiques PCL500 / Anclajes Plásticos PCL500



**PARAFUSOS AGL**  
Chipboard screws  
/ Vis pour aggloméré  
/ Tirafondo



**COLA ESPECIAL PARA PVC P5**  
PVC-U Special Adhesive P5 / Colle Spéciale pour PVC P5 / Adhesivo Especial para PVC P5

**BROCA ENCAIXE CILÍNDRICO MULTIMATERIAIS PREMIUM**  
Multi Construction Multi-Purpose Drill Bit Premium / Foret Polyvalent Multi Construction Premium / Broca de Encaixe Cilíndrico Múltiplos Materiales Premium

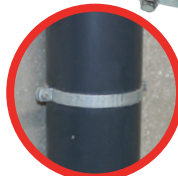

**ABRACADEIRA DE ESPÍGÃO COM PARAFUSO SOLDADO**  
Drain pipe clamp with welded screw  
/ Colliers à pointe a/ vis soudée  
/ Abrazadera de Espigón c/ Tornillo Soldado

**PECLOCKS**  
Anaerobic Adhesives / Anaerobic Adhesives / PECLOCKS



**FITAS PTFE (TEFLON) GÁS (AMARELO) E ÁGUA (AZUL)**  
PTFE (Teflon) Tapes Gas (Yellow) and Water (Blue) / Rubans PTFE (Téflon) Gaz (Jaune) et Eau (Bleu) / Cintas PTFE (Teflón) Gas (Amarillo) y Agua (Azul)



**DISCOS CORTE FINO**  
Flat Cutting Thin Wheels / Meules à Tronçonner fines / Discos Corte Fino

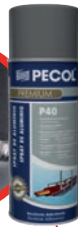

**SPRAY ALUMÍNIO P 40 PREMIUM**  
Aluminium Spray P 40 Premium / Spray Aluminium P 40 Premium / Spray Aluminio P 40 Premium



**ROLO DE FITA PERFURADA**  
Steel fixing band / Rouleau de Bande Perforée / Rollo Cinta Perforada



**GEL PASSA CABOS**  
Gliss Gel / Gel Passe Câbles  
/ Gel Pasa Cables

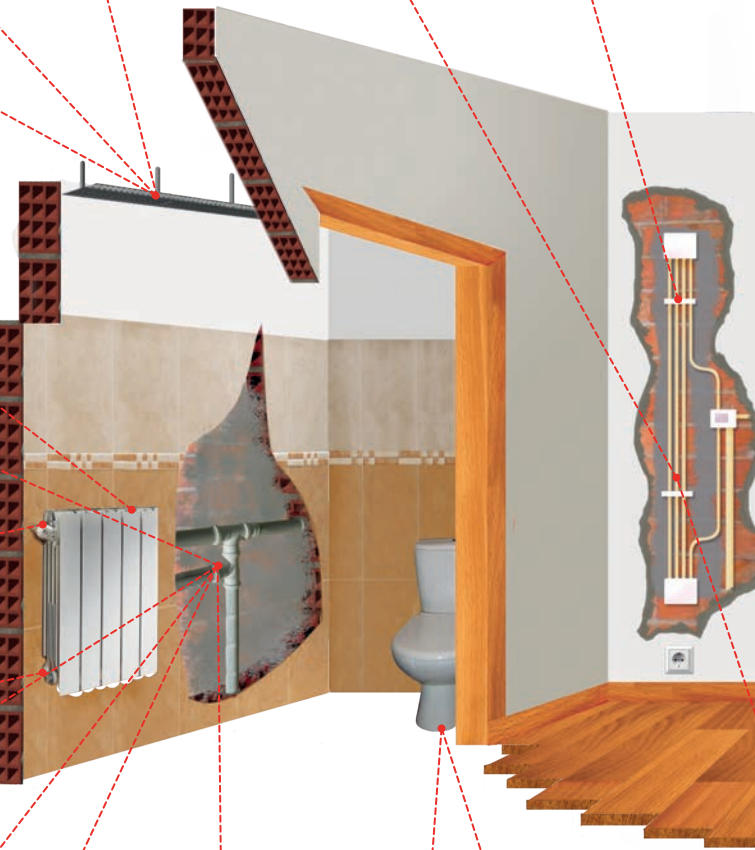

**FITA DE SILICONE "ULTRAFIX TAPE"**  
Silicone Tape "Ultrafix Tape" / Ruban de Silicone "UltraFix Tape" / Cinta de Silicona "UltraFix Tape"



**SILICONE NEUTRO SANITÁRIOS**  
Neutral Sanitary Silicone / Silicone Neutre Sanitaires / Silicona Neutra Sanitarios



**KIT FIXAÇÃO SANITÁRIOS**  
Mounting Kit Toilets / Kit de fixation sanitaires  
/ Kit Fijación de Sanitarios

## EQUIPAMENTO DE PROTEÇÃO INDIVIDUAL

Personal protective equipment / Équipement de protection individuelle / Equipos de protección individual



### FITA DE ALUMÍNIO

Aluminium Foil Tape / Ruban Aluminium / Cinta de Aluminio

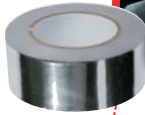

### BROCA ESCALONADA

Step Drill Bits / Fraises Étagées / Brocas Escalonadas



### SELANTE ACRÍLICO

Acrylic Sealant / Mastic Acrylique / Sellante Acrílico



### PARAFUSOS SEXTAVADOS DIN 931

Hexagon head bolts DIN 931 / Vis à tête hexagonale 931 / Tornillería hexagonal 931



### BROCAS SDS PLUS

SDS Plus Hammer Drill / Foret à Marteau SDS Plus / Brocas SDS Plus

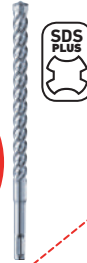

### POLEIAS PARA AR CONDICIONADO

Air Conditioner Brackets / Équerres pour Climatisation / Soportes para Aire Acondicionado



### CALHAS PERFORADAS

Slotted strut channel / Rail perforé / Guia Perforada

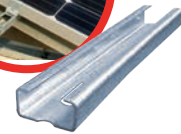

### SPRAY LIMPEZA DE AR CONDICIONADO P 350

Air Conditioning Cleaner P 350 / Spray Nettoyage de Climatisation P 350 / Spray Limpieza de Aire Acondicionado P 350



### BUCHA QUÍMICA VINÍLICA

Chemical Anchor / Mortier de Scellement Chimique / Taco Químico



### BUCHA METÁLICA

PCL752, 783, 784

Metal anchors PCL752, 783, 784 / Chevilles métalliques PCL752, 783, 784 / Anclajes metálicos PCL752, 783, 784

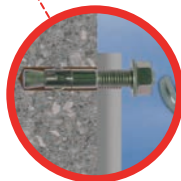

### COLA TERMOFUSÍVEL

Hot Melt Glue / Colle Thermofusible / Cola Termofusible



### COLA DE MONTAGEM PREMIUM

Adhesive Montage Glue Premium / Colle Montage Premium / Adhesivo Montaje Premium



### ABRACADEIRA DE POLIAMIDA

Nylon Cable Tie / Collier de Serrage / Bridas de Nylon



### ESPUMA POLIURETANO B2/B3

PU Foam B2/B3 Premium / Mousse Polyuréthane B2/B3 / Espuma Poliuretano B2/B3



### FERRAMENTA MANUAL

Hand Tools / Outillage Manuel / Herramienta Manual



**PARAFUSOS EXPRESS PLUS PCL211**  
Express Plus Screw PCL211  
/ Vis Express Plus PCL211  
/ Tornillo Express Plus PCL211



**BUCHAS DE POLIAMIDA**  
Nylon plug / Chevilles plastiques  
/ Anclajes Plásticos

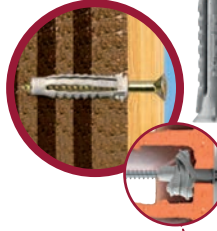

**BUCHA PCL 784 E PCL 764**  
Metal anchors PCL784 and PCL764  
/ Chevilles métalliques PCL784 et PCL764  
/ Anclajes metálicos PCL784 y PCL764

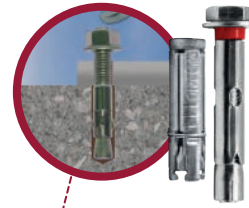

**BROCAS SDS PLUS**  
SDS Plus Hammer Drill  
/ Foret à Marteau SDS Plus  
/ Brocas SDS Plus

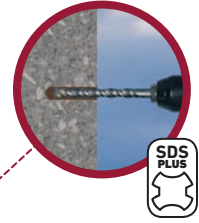

**DISCOS TCT MADEIRA E MELAMINA**

TCT Saw Blades (Wood and Melamine)  
/ Lames de Scie Circulaire (Bois et Mélamine)  
/ Discos Widia (Madera y Melamina)



**CINTAS DE LIXA**  
Roller and Abrasive Belt  
/ Roues et Bande Abrasive  
/ Rodillos y Cintas de Lija



**ESPUMA POLIURETANO B2/B3**  
PU Foam B2/B3 Premium / Mousse Polyuréthane  
B2/B3 / Espuma Poliuretano B2/B3



**PISTOLA PARA PU TEFLON SPECIAL**  
Teflon Gun Special  
/ Pistolet à PU Téflon  
Special / Pistola para PU  
Teflon Special



**COLA PARA MADEIRA D3/D4**  
Cold Wood Adhesive D3/D4 Fast  
/ Colle pour Bois D3/D4 / Cola para Madera D3/D4



**IMPREGNANTES MADEIRA PW10**  
Impregnations for wooden PW10 / Imprégnant pour bois  
PW10 / Impregnante de madera PW10



**DECKPECK SISTEMA DE FIXAÇÃO DE DECKS**  
DeckPec - Deck Fixing system  
/ DeckPec - Système de Fixation de Decks  
/ DeckPec - Sistema de Fijación de Decks

**PREGO PONTA PARIS PCL625**  
Nail PCL625 / Nail PCL625  
/ Clavo PCL625



**COLA DE MONTAGEM PREMIUM**  
Adhesive Montage Glue Premium  
/ Colle Montage Premium  
/ Adhesivo Montaje Premium



**FERRAMENTA MANUAL**  
Hand Tools / Outils Manuel  
/ Herramienta Manual



**IMPERMEABILIZANTE LÍQUIDO**  
Waterproofing Liquid / Produit  
d'étanchéité liquide  
/ Impermeabilizante Líquido



**BUCHA QUÍMICA**  
Chemical Anchor / Mortier de Scellement  
Chimique / Taco Químico



**COLA DE CONTACTO TIXOTRÓPICA**  
Thixotropic Contact Adhesive Gel / Colle de Contact  
Thixotropique / Adhesivo de Contacto Tixotrópico



## EQUIPAMENTO DE PROTEÇÃO INDIVIDUAL

Personal protective equipment / Équipement de protection individuelle / Equipos de protección individual



### SILICONE

Silicone / Silicone / Silicona



### DOBRADIÇAS

Hinge / Charnières / Bisagra



### PARAFUSO AGL PCL 202 E 232

Chipboard screws PCL202 and PCL232 / Vis pour aggloméré PCL202 et PCL232 / Tirafundo PCL202 y PCL232



### TAMPAS DE NYLON

Nylon Screw Cover / Capuchons en Nylon / Tapones de Nylon para tornillos

### BROCA ENCAIXE CILÍNDRICO MULTIMATERIAIS PREMIUM

Multi Construction Multi-Purpose Drill Bit Premium / Foret Polyvalent Multi Construction Premium / Broca de Encaixe Cilíndrica Múltiplos Materiales Premium

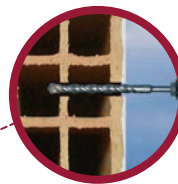

### VARÃO DE ROUPEIRO

Wardrobe Rod / Tringle de Penderie / Barra de Ropero

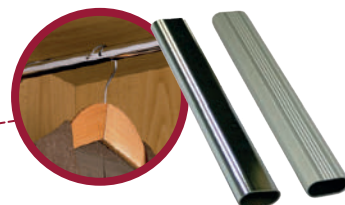

### SELANTE MADEIRA

Wood Sealant / Mastic Bois / Sellante Madera



### ESCAPULAS E CAMARÕES

Cup hook and Square hook / Crochet d'armoire et Gond a vis / Hembrilla abierta y Alcayata con rosca



### COLA POLIURETANO D4

D4 PUR Fast Glue / Colle Polyuréthane D4 / Adhesivo Poliuretano D4



### COLA PU ESTRUTURAL EXPRESS MULTIFIBRAS

Express PU Multifibre Structural Glue / Colle de PU structurel multifibres Express / Cola de PU Estructural Express Multifibras



### COLA P6 COM ATIVADOR

Extra strong adhesive with Activator / Adhésif extra fort avec activateur / Adhesivo extra fuerte con Activador

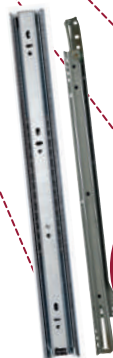

### CORREDIÇAS

Slides / Coulisses / Correderas



### KIT MONTAGEM DE DEGRAUS E BALAUSTRÉS

Mounting KIT for steps and balustrés / KIT de montage pour marches et balustrades / KIT de montaje de balcones y barandillas

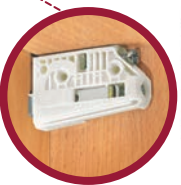

### NIVELADORES

Hanging Brackets / Suspension Réglable / Niveladores

**GCAMAR®**

### SISTEMAS DE UNIÃO

Joint System / Système d'Assemblage / Sistema de Unión

Lamello



### SPRAY LUBRIFICANTE SECO

PTFE P140 / TRANSPARENTE / PTFE Dry Lube Spray P140 / Spray Lubrifiant sec PTFE P140 / Spray Lubrificante seco PTFE P140



### CALHAS PARA PORTAS DE CORRER

Rails for sliding doors / Rails pour portes coulissantes / Rieles para puertas correderas





### SPRAY PROTEÇÃO E LIMPEZA DE AÇO INOX P 70

Stainless Steel Care Spray P 70  
/ Spray de Protection et Nettoyage d'Acier Inox P 70  
/ Spray Protección y Limpieza de Acero Inox P 70

### DOBRADIÇAS SOFT-CLOSE

Soft-closing Hinge / Charnières a/ Soft-Close  
/ Bisagra c/ Soft-Close



### SUPORTES PRATELEIRA

Support Shelf / Supports d'Étagères  
/ Soportes Estanterías



### PUXADORES

Handles / Poignées / Tiradores

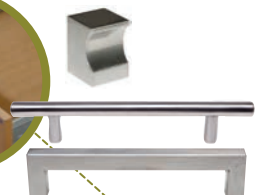

### BATENTES AUTOCOLANTES

Buffer Pads / Butée Autocollante  
/ Batiente Autopegable

### TAMPAS AUTOCOLANTES

Cover Caps / Caches Autocollants  
/ Tapas Autopegables



### PORTA TALHERES

Flatware tray / Range-couverts  
/ Bandeja para cubiertos



### PARAFUSOS AGL

Chipboard screws / Vis pour aggloméré  
/ Tornillo rosca aglomerado



### SILICONE NEUTRO SANITÁRIOS

Neutral Sanitary Silicone /  
Silicone Neutre Sanitaires /  
Silicona Neutra Sanitarios



### DOBRADIÇAS ESPECIAIS

135°, 175°, ...  
Special hinges (135°, 175°, ...)  
/ Charnières spéciales (135°, 175°, ...)  
/ Bisagras especiales (135°, 175°, ...)



### FERRAMENTA MANUAL

Hand Tools / Outillage Manuel / Herramienta Manual



## EQUIPAMENTO DE PROTEÇÃO INDIVIDUAL

Personal protective equipment / Équipement de protection individuelle / Equipos de protección individual



### PERFIL DE ALMÍNIO

Aluminum profile / Profil d'aluminium / Perfil de aluminio

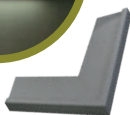

### COMPASSOS A GÁS

Gas Compass / Compas à Gaz / Compás a Gas



### NIVELADORES

Hanging Brackets / Suspension Réglable / Niveladores

**GAMAR®**

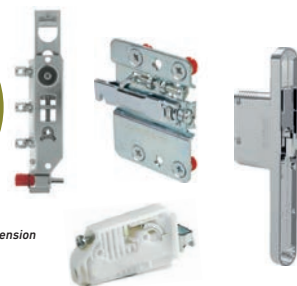

### DOBRADIÇAS APARAFUSAR E CLIP-ON

Slide-on Hinge and Clip-on Hinge / Charnière à Visser et Charnières Clip-On / Bisagra Atornillar y Bisagra Clip-On

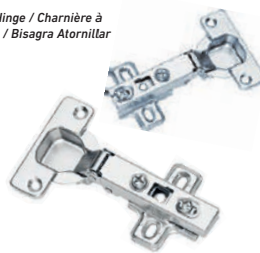

### GAVETA

Drawer / Tiroir / Cajón **G-STARK**

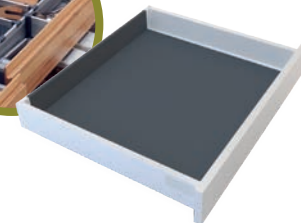

### KIT GAVETÃO

Mid Drawer KIT / Haut Tiroir Set / Set Cajón Alto **G-STARK**

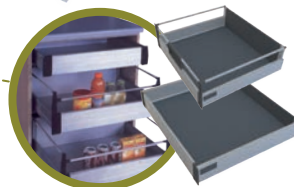
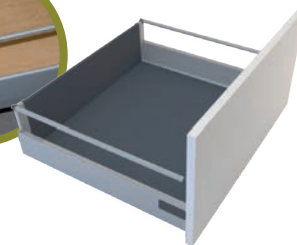
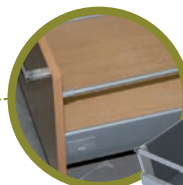

### KIT GAVETA E GAVETÃO INTERIOR

Internal drawer and trundle Kit / Tiroir et tiroir intérieur / Set Cajón interior y Cajón Alto interior **G-STARK**



### FUNDOS, PÉS E RODAPÉS PARA MÓVEIS DE COZINHA

Plastic feet, plinth and others for kitchen furniture / Protection sous évier, pieds et plinthes pour des meubles de cuisine / Fondos, pies y rodapiés para muebles de cocina

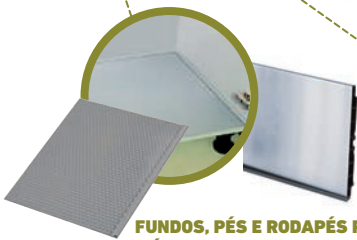

### BALDES DO LIXO

Trash Bucket / Poubelle / Cubo de Basura

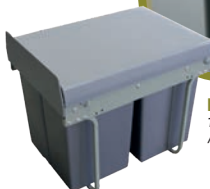

### AMORTECEDOR + TIC-TAC E FECHOS TIC-TAC

Buffer + Push to Open and Push to Open / Amortisseur + Tic-Tac et Fermetures Tic-Tac / Amortiguador + Tic Tac y Cierres Tic Tac





**POLIDORA**  
Polishers / Polisseuse / Pulidora



**MÁSCARA C/ E S/ FILTRO**  
Mask with and without Valve / Masque avec et sans valve / Mascarilla con y sin válvula



**FATO DESCARTÁVEL**  
Disposable Overall / Combinaison jetable / Ropa desechable



**VEDANTE MSP E COLA E VEDA**  
MSP sealant and Polyurethane sealant Cola & Veda / Mastic MSP et Mastic PU / Sellador MSP y Pega y sella

**MASSA REPARADORA AÇO**  
Steel Epoxy Putty Sticks / Pâte Réparatrice Epoxy en Tube / Masilla Reparadora Acero



**FITA DE PINTURA**  
Masking Tape / Ruban de Peinture / Cinta de Pintor



**LUVAS NITRILÓ 376**  
Nitrile Glove 376 / Gants Nitrile 376 / Guante Nitrilo 376



**LUVAS DESCARTÁVEIS PRETAS**  
Disposable Fine Gloves / Gant Jetable / Guantes Desechables



**CARRO DE FERRAMENTAS**  
Tool trolleys / Servantes / Carros



**FERRAMENTA MANUAL**  
Hand Tools / Outillage Manuel / Herramienta Manual



**LIMPEZA DE MOTORES 5LT**  
5LT Engine Cleaning / Nettoyage du Moteur 5LT / Limpieza de Motores 5LT

**SPRAY ÓLEO CORTE E FURAR P220**  
Cutting Oil Spray P 220 / Spray Huile Couper et Percer P 220 / Spray Aceite Corte y Perforado P 220



**MASSA LAVA MÃOS + ROLO PAPEL**  
Hand cleaner + Industrial Paper Rolls / Pâte Nettoyante Mains + Rouleaux de Papier / Masa Lavamanos + Rollos de Papel



**MASSA CONSISTENTE + PISTOLA APLICAÇÃO**  
Multi Purpose Grease + Application gun / Graisse Multifonction + Pistolet d'application / Masilla Consistente + Pistola de aplicación



**PARAFUSO AUTOPERFORANTE CHAPA MATRÍCULA**  
Self Drilling Screws / Vis Autoperceuse / Tornillos Autotaldrantes



**SILICONE ALTAS TEMPERATURAS AEROSOL**  
High Temperature Silicone Sealant Aerosol / Silicone Hautes Températures Aérosol / Silicona Altas Temperaturas Aerosol



**ABRAÇADEIRA POLIAMIDA**  
Nylon Cable Tie / Collier de Serrage / Bridas de Nylon

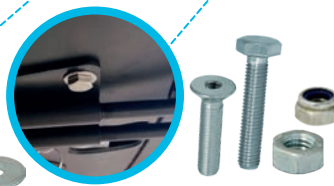

**PARAFUSOS (DIN931, DIN933, DIN7991, DIN912), PORCAS (DIN934, DIN985) E ANILHAS (DIN9021, PCL1126, DIN125)**  
Screws, Nuts and Washers / Vis, Nuts et Rondelles / Tornillos, Tuercas y Arandelas



**REMOVEDOR DE GORDURAS E ÓLEOS**  
Oil and Grass Remover / Nettoyant de Graisses et Huiles / Limpiador de Grasas y Aceites

## EQUIPAMENTO DE PROTEÇÃO INDIVIDUAL

Personal protective equipment / Équipement de protection individuelle / Equipos de protección individual



### LIMPA VIDROS AUTO

Window Car Cleaner / Nettoyant vitres voiture / Limpiador vidrios Auto

### BROCA HSS DIN 338

Twist Drills HSS DIN 338 / Forets HSS DIN 338 / Brocas HSS DIN 338



### REPELENTE ÁGUA PÁRA-BRISAS 500ML

Windshield Water Repellent 500ML / Produit Répulsant l'Eau Pare-brise 500ML / Repelente Agua Parabrisas 500ML



### SHAMPÔ AUTO

Car Shampoo / Shampooing Voiture / Champô Auto



### LIMPA ESTOFOS

Upholstery Car Cleaner / Nettoyant pour textiles / Limpiador tapicería

### CARREGADOR DE BATERIAS

Battery Charger / Chargeur de batterie pour voiture / Cargador de baterias de coche



### SPRAY SILICONE P90

Silicone Spray P90 / Spray Silicone P90 / Spray Silicona P90



### LIMPA TABLIERS

Cockpit Cleaner / Nettoyant de Cockpits / Limpiador salpicaderos



### SPRAY COCKPIT P330

Cleaning and Care Cockpit Spray P330 / Spray Cockpit P330 / Spray Cockpit P330



### DILUENTE

Diluent / Diluant / Diluente



### SPRAY SUPER DETERGENTE P 210

Super Cleaner Spray P 210 / Spray Super Detergent P 210 / Spray Super Detergente P 210



### SPRAY ALUMÍNIO P40 PREMIUM

Aluminium Spray P40 Premium / Spray Aluminium P40 Premium / Spray Aluminio P40 Premium



### INVERSOR M40.20

Inverter M40.20 / Inverseur M40.20 / Inversor M40.20



### FIO DE SOLDA

Solid Wire / Fil de Soudure / Hilo de Soldadura



### SPRAY TURBO P 50 PREMIUM

Spray Turbo P 50 Premium / Spray Turbo P 50 Premium / Spray Turbo P 50 Premium



### SPRAY LIMPEZA DE TRAVÕES P 290

Brake Cleaner Spray P 290 / Spray Nettoyant de Freins P 290 / Spray Limpieza de Frenos P 290



### LIMPA JANTES

Wheels Cleaner / Nettoyant Jantes / Limpiador Llantas



### LIMPA VIDROS CONCENTRADO 32ML

Concentrate Glass Cleansing 32ml / Nettoyant à Vitres Concentré 32ml / Limpia Cristales Concentrados 32ml



### SPRAY LUBRIFICANTE CORRENTES P 180

Chain and Rope Lubricant Spray P 180 / Spray Lubrifiant Chaîne P 180 / Spray Lubrificante Cadenas P 180

**FITA DE SILICONE "ULTRAFIX TAPE"**  
Silicone Tape "UltraFix Tape" / Ruban de Silicone "UltraFix Tape" / Cinta de Silicona "UltraFix Tape"



### ABRILHANTADOR DE PNEUS

Brightener Tires / Brillanteur Pneus / Abrillantador de Neumáticos



### TRAPO

Wiper / Chiffon / Trapo



# REDE ELÉTRICA | TELEFÓNICA | AUTOESTRADAS

Electric | Telephonic Installations | Highway / Réseau électrique | Téléphonique | Autoroutes / Red Eléctrica | Telefónica | Autopistas

## Parafuso Fusível

Aço 5.8/8.8 HDG

Fuse screw - Steel 5.8/8.8 HDG

Vis Fuse - Acier 5.8/8.8 HDG

Tornillo Fusible - Acero 5.8/8.8 HDG



## Parafuso DIN 931/933

Aço 6.8/8.8 HDG

Screw DIN 931/933 - Steel 6.8/8.8 HDG

Vis DIN 931/933 - Acier 6.8/8.8 HDG

Tornillo DIN 931/933 - Acero 6.8/8.8 HDG



## Parafuso DIN 603

Aço 5.8/8.8 HDG

Screw DIN 603 - Steel 5.8/8.8 HDG

Vis DIN 603 - Acier 5.8/8.8 HDG

Tornillo DIN 603 - Acero 5.8/8.8 HDG



## Parafuso DIN 571

Aço 4.8 HDG

Screw DIN 571 - Steel 4.8 HDG

Vis DIN 571 - Acier 4.8 HDG

Tornillo DIN 571 - Acero 4.8 HDG



## Abarcone

Aço 4.8/5.8/8.8 HDG

Ubolt - Steel 4.8/5.8/8.8 HDG

Boulon en U - Acier 4.8/5.8/8.8 HDG

Abarcón - Acero 4.8/5.8/8.8 HDG



## Rebite Maciço Cabeça Oval

Aço 4.8/5.8/8.8 HDG

Solid rivet with oval head - Steel 4.8/5.8/8.8 HDG

Rivet plein à tête ronde - Acier 4.8/5.8/8.8 HDG

Remache Maciço Cabeça Ovalada - Acero 4.8/5.8/8.8 HDG



## Parafuso Cabeça Hexagonal c/ Furo

Aço 6.8/8.8 HDG

Hexagonal screw with hole - Steel 6.8/8.8 HDG

Vis tête Hexagonal avec trou de guidage - Acier 6.8/8.8 HDG

Tornillo Hexagonal Cabeça c/ Agujero - Acero 6.8/8.8 HDG



## Parafuso Autoestrada

Aço 5.8 HDG (16x30 mm, 16x40 mm)

Highway screw - Steel 5.8 HDG

Vis TRCO - Acier 5.8 HDG

Tornillo de Carretera - Acero 5.8 HDG



## Conjunto DIN 7990/934/125/127

Aço 5.6/6.8/8.8 HDG

Set DIN 7990/934/125/127 - Steel 5.6/6.8/8.8 HDG

Set DIN 7990/934/125/127 - Acier 5.6/6.8/8.8 HDG

Conjunto DIN 7990/934/125/127 - Acero 5.6/6.8/8.8 HDG



## Anilha Redonda

ST37 HDG (17x35x4 mm)

Round washer - ST37 HDG

Rondelle plat - ST37 HDG

Arandela Redonda - ST37 HDG



## Conjunto DIN 7990/934/7989

Aço 5.6/6.8/8.8 HDG

Set DIN 7990/934/7989 - Steel 5.6/6.8/8.8 HDG

Set DIN 7990/934/7989 - Acier 5.6/6.8/8.8 HDG

Conjunto DIN 7990/934/7989 - Acero 5.6/6.8/8.8 HDG



## Anilha Quadrada

ST37 HDG (40x33x5 mm)

Square washer - ST37 HDG

Rondelle carré - ST37 HDG

Arandela Cuadrada - ST37 HDG

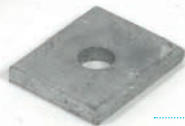

## Parafuso Autoestrada c/ Fusível

Aço 5.8 HDG (16x30 mm, 16x40 mm)

Highway screw with fuse - Steel 5.8 HDG

Vis TRCO avec Fuse - Acier 5.8 HDG

Tornillo de la Carretera c/ Fusible - Acero 5.8 HDG

## Anilha Retangular

ST37 HDG (55x40x5 mm (ø int. 18x30 mm))

Rectangular washer - ST37 HDG

Rondelle rectangulaire - ST37 HDG

Arandela Rectangular - ST37 HDG



## Anilha Quadrada

ST37 HDG (40x40x5 mm)

Square washer - ST37 HDG

Rondelle carré - ST37 HDG

Arandela Cuadrada - ST37 HDG

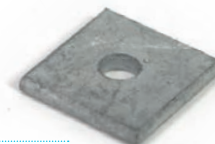

# COBERTURAS

Coverage Fasteners / Toiture / Recubrimientos

## PCL 613 Prego para Estrutura

PCL 613 Nail for structures  
PCL 613 clou pour structure  
PCL 613 Clavo para Estrutura



## Parafuso DIN 7504 K

Screw DIN 7504 K  
Vis DIN 7504 K  
Tornillo DIN 7504 K



## Parafuso PCL 9761

Screw PCL 9761  
Vis PCL 9761  
Tornillo PCL 9761



## Parafuso PCL 9762

Screw PCL 9762  
Vis PCL 9762  
Tornillo PCL 9762



## Grampo PCL 977

Clip PCL 977  
Clip PCL 977  
Presilla PCL 977



## Parafuso PCL 8970

Screw PCL 8970  
Vis PCL 8970  
Tornillo PCL 8970



## Parafuso PCL 8971

Screw PCL 8971  
Vis PCL 8971  
Tornillo PCL 8971



# AGRICULTURA

Agriculture Fasteners / Agriculture / Agricultura

## Parafuso Arr. Quad. Cab. Emb. DIN 608

Flat Countersunk, Square Neck, Screw DIN 608  
Vis a tête fraisée empreinte et collé carre DIN 608  
Tornillo Cab. Cuad. Plana Cuello Cuad. Norma DIN 608



## Parafuso Arr. Quad. Cab. Oval DIN 603

Mushroom Head, Square Neck, Screw DIN 603  
Vis a tête ronde et collé carre DIN 603  
Tornillo Cab. Oval. Plana Cuello Cuad. Norma DIN 603



## Parafuso DIN 960 Passo Fino R.P.

Hexagon Screw DIN 960, Fine Pitch Thread  
VIS DIN 960 pas fin  
Tornillo DIN 960 Paso Fino



## Parafuso DIN 961 Passo Fino R.T.

Hexagon Screw DIN 961, Fine Pitch Thread  
VIS DIN 961 pas fin  
Tornillo DIN 961 Paso Fino



## Parafuso PCL 1933 UNC

Screw PCL 1933 UNC  
VIS PCL 1933 UNC  
Tornillo PCL 1933 UNC



## Parafuso PCL 2933 UNF

Screw PCL 2933 UNF  
VIS PCL 2933 UNF  
Tornillo PCL 2933 UNF



## Parafuso Cabeça Cônica c/Porca

Conical Screw with Nut  
Vis tête fraisée avec écrou  
Tornillo Cabeça Cônica c/Tuerca



## Parafuso Cabeça Cônica Quad. especial

Conical Square, Head Screw  
Vis tête fraisée collet carré spécial  
Tornillo Cabeça Cônica Cuad. Especial



## Parafuso Cabeça Sextavada Rosca Parcial Especial

Special Hexagon Screw with Partial Thread  
Vis tête Hexagonal filetage partiel spécial  
Tornillo Cabeça Hexagonal Rosca Parcial Especial



## Parafuso Cabeça Oval Quad. c/porca

Square Oval Screw with Nut  
Vis tête ronde collet carré avec écrou  
Tornillo Cabeça Oval Cuad. c/Tuerca



## Parafuso Cabeça Xata Oval c/porca

Flat Screw with Nut  
Vis tête fraisée Bombée avec écrou  
Tornillo Cabeça Plana Oval c/Tuerca



## Parafuso Cabeça Cônica Rosca Total c/Porca

Conical Screw with Total Thread and Nut  
Vis tête fraisée filetage complet avec écrou  
Tornillo Cabeça Cônica Rosca Total c/Tuerca



## Parafuso Cabeça Embeber Quad. c/ Porca

Countersunk Screw with Nut  
Vis tête fraisée collet carré avec écrou  
Tornillo Cabeça Avellanada Cuello Cuad. c/Tuerca



## Parafuso cabeça xata quad. UNF

Square Flat Hexagon Screw UNF  
vis tête fraisée collet UNF  
Tornillo Cabeça Plana Cuad. UNF



## Parafuso Cabeça Cônica Quad.

Conical Square Screw  
Vis tête fraisée carré  
Tornillo Cabeça Cônica Cuad.



# FIXAÇÃO DE ALTA RESISTÊNCIA

High-tensile Fasteners / Fixation Haute Résistance / Fijación de Alta Resistencia

## PARAFUSO SEXTAVADO INTERIOR

SOCKET HEAD SCREW / SIX PANS CREUX / TORNILLERIA ALLEN

### PARAFUSO CABEÇA CILÍNDRICA COM SEXTAVADO INTERIOR

Hexagon socket head cap screws / Vis à tête cylindrique à 6 pans creux / Tornillo de cabeça cilíndrica com hueco hexagonal



M1.6 ~ M64

12.9

DIN 912

ISO 4762

### PARAFUSO CABEÇA DE EMBEBER COM SEXTAVADO INTERIOR

Hexagon socket countersunk head cap screws / Vis à tête fraisée à 6 pans creux / Tornillo de cabeça avellanada com hueco hexagonal



M3 ~ M20

10.9

DIN 7991

ISO 10642

### PARAFUSO CABEÇA OVAL COM SEXTAVADO INTERIOR

Hexagon socket head cap screws / Vis à tête bombée à six pans creux / Tornillo de cabeça abombada com hueco hexagonal



M3 ~ M12

10.9

DIN 7380

ISO 7380

### PERNO DE ROSCA MÉTRICA COM PONTA CÔNICA E SEXTAVADO INTERIOR

Hexagon socket set screw cone point / Vis sans tête à six pans creux bout pointeau / Espárrago roscado con hexágono interior y extremo cónico



M3 ~ M24

C45H

DIN 914

ISO 4027

### PERNO DE ROSCA MÉTRICA COM PONTA BISELADA E SEXTAVADO INTERIOR

Hexagon socket set screw with dog point / Vis sans tête à six pans creux bout téton / Tornillo sin cabeza con hueco hexagonal y pivote



M3 ~ M24

C45H

DIN 915

ISO 4028

### PERNO DE ROSCA MÉTRICA COM PONTA LISA E SEXTAVADO INTERIOR

Hexagon socket set screw plain cup point / Vis sans tête à six pans creux bout cuvette / Tornillo sin cabeza con hueco hexagonal y extremo biselado hueco



M3 ~ M24

C45H

DIN 916

ISO 4029





**PARAFUSO SEXTAVADO**  
 HEXAGON HEAD BOLTS / VIS À TÊTE HEXAGONALE / TORNILLERIA HEXAGONAL

**ANILHA**  
 WASHER / RONDELLE / ARANDELA

**ACESSÓRIO**  
 ACCESSORY / ACCESSOIRE / ACCESORIO

**PARAFUSO CABEÇA SEXTAVADA ROSCA MÉTRICA PARCIAL, PASSO FINO**  
*Hexagon bolt metric, fine pitch thread / Vis à tête hexagonale filetage métrique partiel, pas fin / Tornillo de cabeza hexagonal, rosca metrica fina parcial*

**PARAFUSO CABEÇA SEXTAVADA ROSCA MÉTRICA TOTAL, PASSO FINO**  
*Hexagon screws metric, fine pitch thread / Vis à tête hexagonale filetage métrique total, pas fin / Tornillo de cabeza hexagonal, rosca metrica fina total*

**PARAFUSO CABEÇA SEXTAVADA COM FALSA ANILHA**  
*Hexagon flange head bolt / Vis à tête hexagonale à embase / Tornillo de cabeza hexagonal con brida sin estrías*

**PARAFUSO CABEÇA SEXTAVADA COM FALSA ANILHA C/ RECARTILHA**  
*Hexagon flange head bolt with knurl / Vis à tête hexagonale à embase avec rondelle moletée / Tornillo de cabeza hexagonal con brida*

**ANILHA NORD-LOCK**  
*Nord-Lock washer / Rondelle Nord-Lock / Arandela Nord-Lock*

**CHAVE SEXTAVADA**  
*Hexagon socket screw key / Clé mâle coudée pour vis à six pans creux / Llave hexagonal para tornillos con hueco hexagonal*

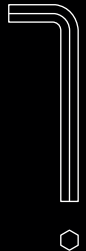
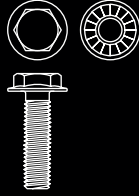

<b>M8 ~ M24</b>
8.8   10.9
DIN 960
ISO 8765

<b>M8 ~ M24</b>
8.8   10.9
DIN 961
ISO 8676

<b>M5 ~ M20</b>
8.8   10.9
DIN 6921
ISO 4162

<b>M5 ~ M20</b>
8.8   10.9
DIN 6921
ISO 4162

<b>M6 ~ M42</b>
8.8   10.9   12.9   INOX
-
-

<b>2 ~ 36 mm</b>
10.9
DIN 911
ISO 2936



# NOVO SISTEMA DE ORGANIZAÇÃO DE STOCK

NEW STOCK ORGANIZATION SYSTEM / NOUVEAU SYSTÈME D'ORGANISATION DES STOCKS / NUEVO SISTEMA DE ORGANIZACIÓN DE STOCK



**SIMPLES**, você decide qual o stock que pretende por referência  
 SIMPLE, you decide which stock you want by reference / SIMPLE, vous décidez quel stock vous voulez par référence / SIMPLE, usted decide cuál es el stock que desea por referencia



**TRANSPARENTE**, antes de enviarmos a mercadoria receberá um email para confirmar as quantidades e referências encomendadas  
 TRANSPARENT, before sending the Merchandise you will receive an email to confirm the quantities and references ordered / TRANSPARENT, avant d'envoyer la marchandise vous recevrez un email pour confirmer les quantités et références commandées / TRANSPARENTE, antes de enviar la mercancía recibirá un email para confirmar las cantidades y referencias encomendadas



**SEGURO**, não corre o risco de ficar sem stock e ficar com a produção parada  
 RELIABLE, you are not at risk of running out of stock and having production downtime / SECURITÉ, vous ne courez pas le risque de manquer de stock et d'arrêter la production / SEGURO, no corre el riesgo de quedarse sin stock y con una parada de producción



**POUPANÇA**, não necessita de perder tempo a separar as várias encomendas dos vários fornecedores  
 SAVINGS, no need to waste time separating the several orders from various suppliers / ÉCONOMIES, pas besoin de perdre du temps à séparer les différentes commandes des plusieurs fournisseurs / AHORRO, no necesita perder tiempo separando los diversos pedidos de los distintos proveedores



**ORGANIZADO**, o seu stock sempre organizado pelo nosso comercial  
 ORGANISED, your stock always organised by our commercial / ORGANISÉ, votre stock est toujours organisé par notre commercial / ORGANIZADO, su stock siempre organizado por nuestro comercial

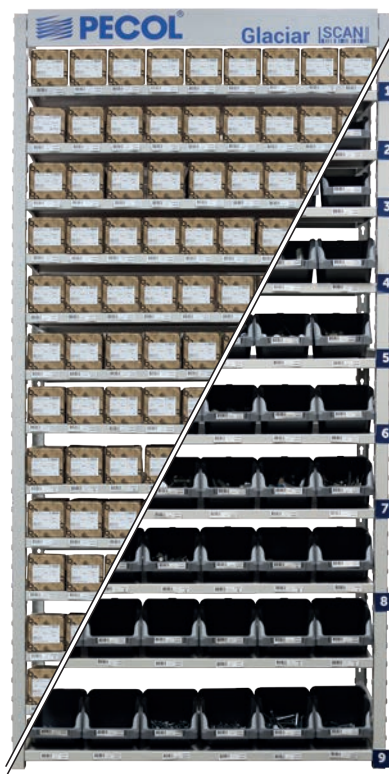

## UMA VASTA GAMA AO SEU DISPOR

A wide range at your disposal / Une large gamme à votre disposition / Una amplia gama a su disposición

**PARAFUSOS, PORCAS E ANILHAS - BUCHAS NYLON E METÁLICAS - SILICONES E SELANTES - SPRAYS**  
**BROCAS HSS E SDS-PLUS - DISCOS ABRASIVOS E DIAMANTADOS - ELÉTRODOS**

Bolts, Nuts and Rings - Nylon Plugs and Metallic Anchors - Silicones and Sealants - Sprays - HSS and SDS-Plus Drills - Abrasive Discs and Diamond Wheel - Electrodes  
 / Vis, Écrous et Anneaux - Chevilles Métalliques et Plastiques - Étanches et Mastics - Sprays - Forets HSS et SDS-Plus - Disques Abrasifs et Diamant - Électrodes  
 / Tornillos, Tuercas y Arandelas - Anclajes Metálicos e Plásticos - Siliconas y Sellantes - Sprays - Brocas HSS y SDS-Plus - Discos Abrasivos y Diamantados - Electrodo





# TABELA PCL E DIN'S

PCL AND DIN TABLE  
TABLEAU DE PCL'S ET DIN'S  
TABLA DE PCL'S Y DIN'S

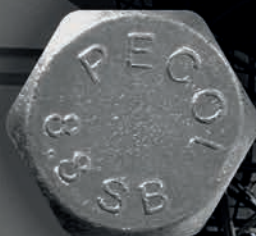

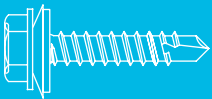

# TABELA PCL'S E DIN'S

PCL and DIN table / Tableau de PCL's et DIN's / Tabla de PCL's y DIN's

## DIN / PCL

### PARAFUSOS CABEÇA HEXAGONAL / HEXAGONAL BOLTS / VIS A TÊTE HEXAGONAL / TORNILLOS CABEÇA HEXAGONAL



### PF. ROSCA MADEIRA E AGLOMERADO / WOOD AND CHIPBOARD SCREWS / VIS À BOIS/ VIS AGLO / TORNILLOS ROSCA MADERA Y AGLOMERADO

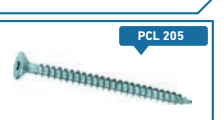

### PARAFUSOS AUTO-ROSCANTES / SELF TAPPING SCREWS / VIS À TÔLE / TORNILLOS AUTORROSCANTES

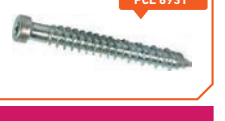

### PARAFUSOS ROSCA PVC / PVC SCREWS / VIS POUR MENUISERIE PVC / TORNILLOS ROSCA PVC



### PARAFUSOS ALLEN / ALLEN BOLTS / SIX PANS CREUX / TORNILLOS ALLEN



 PCL 7509	 DIN 412	 DIN 660	 DIN 980 V	 PCL 934 FENOX	 DIN 6797 J
 PCL 8974	 DIN 420	 DIN 661	 DIN 982	 PCL 941	 DIN 6798 A
 PCL 9800	 PCL 421	 DIN 741	 DIN 985	 PCL 935	 DIN 6798 J
 PCL 9761	 PCL 422	 DIN 1478	 DIN 986	 PCL 6919	 DIN 6799
 PCL 9762	 PCL 430	 DIN 1480	 DIN 1587	<b>ANILHAS</b> / WASHERS / RONDELLES / ARANDELAS	 EN 14399-6
 PCL 8971	 PCL 450	 DIN 1481	 UNI 5587		 DIN 125 ISO 7980
 PCL 0007227949	 PCL 610	 DIN 911	 DIN 6923	 DIN 127	 DIN 7989
 PCL 8970	 PCL 620	<b>PORCAS</b> / NUT / ECROU / TUERCAS	 DIN 6331	 DIN 137 A	 DIN 9021 ISO 7093
<b>OUTROS</b> / OTHERS / AUTRES / OTROS	 PCL 610 Rosca Madeira		 DIN 557	 DIN 6334	 DIN 433
	 DIN 94	 PCL 620 Rosca Madeira	 DIN 562	 EN 14399-4	 DIN 434
 PCL 95	 PCL 630 Rosca Madeira	 DIN 917	 DIN 7967	 DIN 440 R	 PCL 0001
 PCL 96	 PCL 665	 DIN 928	 PCL 1934 UNC	 DIN 471	 PCL 0002
 PCL 90	 DIN 124	 DIN 929	 PCL 1934	 DIN 472	 PCL 0002
 DIN 316	 DIN 444	 DIN 934	 PCL 2934 UNF	 DIN 2093	 <b>CATÁLOGO TÉCNICO</b> FIXING CATALOGUE / CATALOGUE TECHNIQUE / CATÁLOGO TÉCNICO
 DIN 411	 DIN 582	 DIN 935	 PCL 315	 DIN 6796	
 DIN 1411	 DIN 580	 DIN 936	 PCL 934 Sextavado Interior	 DIN 6796 A	





**O SEU FORNECEDOR DE SEMPRE,  
ONDE ESTIVER!**

*/ Your ever-ready supplier, wherever you are! / Votre fournisseur de  
toujours, où que vous soyez! / Su proveedor de siempre, donde esté!*

[HTTP://STORE.PECOL.PT/](http://store.pecol.pt/)

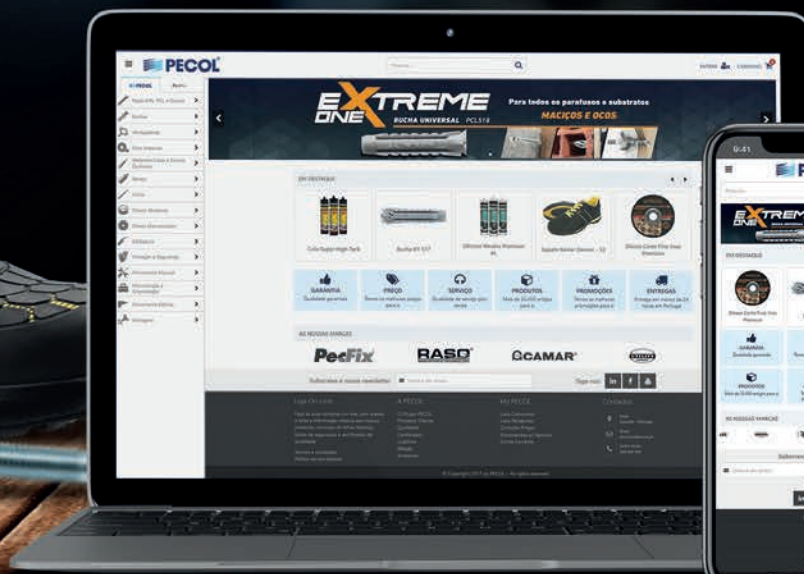



# **PARAFUSOS ROSCA MÉTRICA**

*METRIC THREAD SCREW*

*VIS FILET MÉTRIQUE*

*TORNILLOS ROSCA MÉTRICA*

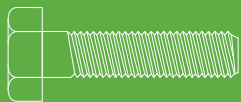

# PARAFUSOS ROSCA MÉTRICA

Metric thread screw / Vis filet métrique / Tornillos rosca métrica

## DIN 931

### Parafuso Cabeça Sextavada Rosca Métrica Parcial

Hexagon bolt metric coarse pitch thread / Vis à tête hexagonale pas large, filetage métrique partiel / Tornillos de cabeza hexagonal, parcialmente roscados

DIN 931

Zincado / Zinc Plated / Zingué / Zincado



#### MATÉRIAS PRIMAS

RAW MATERIALS / CLASSE DE RÉSISTANCE / CLASE DE RESISTENCIA



#### ACABAMENTOS

FINISHES / FINITIONS / ACABADOS



#### MAIS MEDIDAS

##### DISPONÍVEIS EM GAMA

MORE MEASUREMENTS AVAILABLE IN RANGE / PLUS DE MESURES DISPONIBLES DANS LA GAMME / MÁS MEDIDAS DISPONIBLES EN GAMA

CÓDIGO CODE / CODE / CÓDIGO	DIMENSÕES SIZE / DIMENSIONS MEDIDA	EMBALAGEM QUANTITY / EMBALLAGE / EMBALAJE	CÓDIGO CODE / CODE / CÓDIGO	DIMENSÕES SIZE / DIMENSIONS MEDIDA	EMBALAGEM QUANTITY / EMBALLAGE / EMBALAJE
093122080400	M8X40	200	093122140800D	M14X80	25
093122080450	M8X45	200	093122141000D	M14X100	25
093122080500	M8X50	100	093122141100D	M14X110	25
093122080600	M8X60	100	093122160500	M16X50	50
093122080650	M8X65	100	093122160550	M16X55	50
093122080700	M8X70	100	093122160600	M16X60	25
093122080800	M8X80	100	093122160650	M16X65	25
093122080850	M8X85	100	093122160700	M16X70	25
093122080900	M8X90	100	093122160800	M16X80	25
093122081000	M8X100	100	093122160900	M16X90	25
093122081100	M8X110	50	093122161000	M16X100	25
093122081200	M8X120	50	093122161100	M16X110	25
093122081300	M8X130	50	093122161200	M16X120	25
093122100400D	M10X40	100	093122161300	M16X130	25
093122100500D	M10X50	100	093122161400	M16X140	25
093122100600D	M10X60	100	093122161500	M16X150	25
093122100650D	M10X65	100	093122161600	M16X160	25
093122100700D	M10X70	50	093122161700	M16X170	25
093122100800D	M10X80	50	093122180600	M18X60	25
093122100900D	M10X90	50	093122180650	M18X65	25
093122101000D	M10X100	50	093122180700	M18X70	25
093122101100D	M10X110	50	093122180750	M18X75	25
093122101200D	M10X120	50	093122180800	M18X80	25
093122101300D	M10X130	50	093122180900	M18X90	25
093122101400D	M10X140	50	093122181000	M18X100	25
093122101600D	M10X160	50	093122181200	M18X120	25
093122101800D	M10X180	25	093122200600	M20X60	25
093122120350D	M12X35	100	093122200650	M20X65	25
093122120400D	M12X40	100	093122200700	M20X70	25
093122120450D	M12X45	100	093122200750	M20X75	25
093122120500D	M12X50	100	093122200800	M20X80	25
093122120550D	M12X55	100	093122200900	M20X90	15
093122120600D	M12X60	50	093122201000	M20X100	15
093122120700D	M12X70	50	093122201100	M20X110	15
093122120800D	M12X80	50	093122201200	M20X120	15
093122120900D	M12X90	50	093122201300	M20X130	15
093122121000D	M12X100	25	093122201400	M20X140	15
093122121100D	M12X110	25	093122201500	M20X150	15
093122121200D	M12X120	25	093122201600	M20X160	10
093122121300D	M12X130	25	093122201800	M20X180	10
093122121400D	M12X140	25	093122202000	M20X200	10
093122121500D	M12X150	25	093122220700D	M22X70	25
093122122000D	M12X200	25	093122221500D	M22X150	15
093122122200D	M12X220	25	093122240800	M24X80	10
093122140600D	M14X60	50	093122241000	M24X100	10

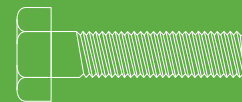

## Parafuso Cabeça Sextavada Rosca Métrica e Total

Hexagon bolt metric coarse, pitch thread / Vis à tête hexagonale filetage métrique total, pas large / Tornillos de cabeza hexagonal, totalmente roscados

# DIN 933

Zincado / Zingué / Zinc Plated / Zincado

DIN 933



CÓDIGO CODE / CODE / CÓDIGO	DIMENSÕES SIZE / DIMENSIONS MEDIDA	EMBALAGEM QUANTITY / EMBALLAGE / EMBALAJE
093322050200	M5X20	500
093322050250	M5X25	500
093322050300	M5X30	500
093322060100	M6X10	500
093322060120	M6X12	500
093322060160	M6X16	500
093322060200	M6X20	500
093322060250	M6X25	500
093322060300	M6X30	200
093322060350	M6X35	200
093322060400	M6X40	200
093322060500	M6X50	200
093322060600	M6X60	200
093322060700	M6X70	200
093322060800	M6X80	100
093322060900	M6X90	100
093322061000	M6X100	100
093322080120	M8X12	200
093322080160	M8X16	200
093322080200	M8X20	200
093322080250	M8X25	200
093322080300	M8X30	200
093322080350	M8X35	200
093322080400	M8X40	200
093322080450	M8X45	200
093322080500	M8X50	100
093322080550	M8X55	100
093322080600	M8X60	100
093322080650	M8X65	100
093322080700	M8X70	100
093322080800	M8X80	100
093322080900	M8X90	100
093322081000	M8X100	100
093322100200D	M10X20	200
093322100250D	M10X25	200
093322100300D	M10X30	200
093322100350D	M10X35	100
093322100400D	M10X40	100
093322100450D	M10X45	100
093322100500D	M10X50	100
093322100600D	M10X60	100
093322100700D	M10X70	50
093322100800D	M10X80	100
093322100900D	M10X90	50
093322101000D	M10X100	50

CÓDIGO CODE / CODE / CÓDIGO	DIMENSÕES SIZE / DIMENSIONS MEDIDA	EMBALAGEM QUANTITY / EMBALLAGE / EMBALAJE
093322101200D	M10X120	25
093322120200D	M12X20	100
093322120250D	M12X25	100
093322120300D	M12X30	100
093322120350D	M12X35	100
093322120400D	M12X40	100
093322120450D	M12X45	100
093322120500D	M12X50	100
093322120600D	M12X60	50
093322120700D	M12X70	50
093322120800D	M12X80	50
093322120900D	M12X90	50
093322121000D	M12X100	50
093322140250D	M14X25	100
093322140300D	M14X30	100
093322140350D	M14X35	50
093322140400D	M14X40	50
093322140450D	M14X45	50
093322140500D	M14X50	50
093322140600D	M14X60	50
093322140800D	M14X80	25
093322160300	M16X30	50
093322160350	M16X35	50
093322160400	M16X40	50
093322160450	M16X45	50
093322160500	M16X50	50
093322160550	M16X55	50
093322160600	M16X60	25
093322160650	M16X65	25
093322160700	M16X70	25
093322160750	M16X75	25
093322160800	M16X80	25
093322160900	M16X90	25
093322161000	M16X100	25
093322180500	M18X50	50
093322180600	M18X60	25
093322200500	M20X50	25
093322200550	M20X55	25
093322200600	M20X60	25
093322200650	M20X65	25
093322200700	M20X70	25
093322200750	M20X75	25
093322200800	M20X80	25
093322200900	M20X90	15
093322201000	M20X100	15



**MATÉRIAS PRIMAS**  
RAW MATERIALS / CLASSE DE RESISTANCE /  
CLASE DE RESISTENCIA



**ACABAMENTOS**  
FINISHES / FINITIONS / ACABADOS



**MAIS MEDIDAS**  
**DISPONÍVEIS EM GAMA**  
MORE MEASUREMENTS AVAILABLE IN RANGE  
/ PLUS DE MESURES DISPONIBLES DANS LA GAMME  
/ MÁS MEDIDAS DISPONIBLES EN GAMA

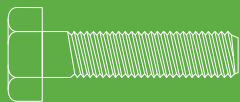

# PARAFUSOS ROSCA MÉTRICA

Metric thread screw / Vis filet métrique / Tornillos rosca métrica

## DIN 912 Parafuso Cabeça Cilíndrica com Sextavado Interior

Hexagon socket head cap screws / Vis à tête cylindrique à 6 pans creux / Tornillo de cabeza cilíndrica con hueco hexagonal

DIN 912

Zincado / Zinc Plated / Zingué / Zincado

A 8.8 Z ZINC



CÓDIGO CODE / CODE / CÓDIGO	DIMENSÕES SIZE / DIMENSIONS MEDIDA	EMBALAGEM QUANTITY / EMBALLAGE / EMBALAJE
091222040100	M4X10	1000
091222040160	M4X16	1000
091222040200	M4X20	500
091222050100	M5X10	1000
091222050120	M5X12	1000
091222050160	M5X16	500
091222050180	M5X18	500
091222050200	M5X20	500
091222050250	M5X25	500
091222050300	M5X30	500
091222060100	M6X10	500
091222060120	M6X12	500
091222060140	M6X14	500
091222060160	M6X16	500
091222060200	M6X20	500
091222060250	M6X25	500
091222060300	M6X30	200
091222060350	M6X35	200
091222060400	M6X40	200
091222060450	M6X45	200
091222060600	M6X60	200
091222060650	M6X65	200
091222080100	M8X10	200

CÓDIGO CODE / CODE / CÓDIGO	DIMENSÕES SIZE / DIMENSIONS MEDIDA	EMBALAGEM QUANTITY / EMBALLAGE / EMBALAJE
091222080160	M8X16	200
091222080200	M8X20	200
091222080250	M8X25	200
091222080300	M8X30	200
091222080350	M8X35	200
091222080400	M8X40	200
091222080450	M8X45	200
091222080500	M8X50	100
091222080550	M8X55	100
091222080600	M8X60	100
091222080800	M8X80	100
091222100200	M10X20	200
091222100250	M10X25	200
091222100300	M10X30	200
091222100400	M10X40	100
091222100500	M10X50	100
091222100600	M10X60	100
091222100700	M10X70	50
091222120300	M12X30	100
091222120350	M12X35	100
091222120400	M12X40	100
091222120500	M12X50	100
091222121000	M12X100	25

### ACABAMENTOS FINISHES / FINITIONS / ACABADOS



### MAIS MEDIDAS DISPONÍVEIS EM GAMA

MORE MEASUREMENTS AVAILABLE IN RANGE  
/ PLUS DE MESURES DISPONIBLES DANS LA GAMME  
/ MÁS MEDIDAS DISPONIBLES EN GAMA

## DIN 7380 Parafuso Cabeça Oval com Sextavado Interior

Hexagon socket head cap screws / Vis à tête bombée à six pans creux / Tornillo de cabeza abombada con hueco hexagonal

DIN 7380

Zincado / Zinc Plated / Zingué / Zincado

A 10.9 Z ZINC



CÓDIGO CODE / CODE / CÓDIGO	DIMENSÕES SIZE / DIMENSIONS MEDIDA	EMBALAGEM QUANTITY / EMBALLAGE / EMBALAJE
738032040100	M4x10	1000
738032040120	M4x12	1000
738032050100	M5X10	1000
738032050120	M5X12	1000
738032050160	M5X16	500
738032050200	M5X20	500
738032050250	M5X25	500
738032060100	M6X10	500
738032060120	M6X12	500
738032060160	M6X16	500
738032060200	M6X20	500
738032060250	M6X25	500
738032060300	M6X30	200
738032060350	M6X35	200
738032060400	M6X40	200
738032060450	M6X45	200
738032060500	M6X50	200
738032060600	M6X60	200
738032080120	M8X12	200
738032080160	M8X16	200

CÓDIGO CODE / CODE / CÓDIGO	DIMENSÕES SIZE / DIMENSIONS MEDIDA	EMBALAGEM QUANTITY / EMBALLAGE / EMBALAJE
738032080200	M8X20	200
738032080250	M8X25	200
738032080300	M8X30	200
738032080350	M8X35	200
738032080400	M8X40	200
738032080450	M8X45	200
738032080500	M8X50	100
738032080600	M8X60	100
738032080700	M8X70	100
738032080800	M8X80	50
738032100160	M10X16	200
738032100200	M10X20	200
738032100250	M10X25	200
738032100350	M10X35	100
738032100400	M10X40	100
738032100500	M10X50	100
738032100700	M10X70	100
738032120250	M12X25	100
738032120300	M12X30	100
738032120350	M12X35	100

### ACABAMENTOS FINISHES / FINITIONS / ACABADOS



### MAIS MEDIDAS DISPONÍVEIS EM GAMA

MORE MEASUREMENTS AVAILABLE IN RANGE  
/ PLUS DE MESURES DISPONIBLES DANS LA GAMME  
/ MÁS MEDIDAS DISPONIBLES EN GAMA



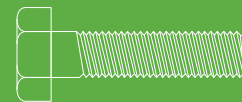

## Parafuso Cabeça de Embeber com Sextavado Interior

Hexagon socket countersunk head cap screws / Vis à tête fraisée à 6 pans creux  
/ Tornillo de cabeza avellanada con hueco hexagonal

# DIN 7991

Zincado / Zingué / Zinc Plated / Zincado

DIN 7991



CÓDIGO CODE / CODE / CÓDIGO	DIMENSÕES SIZE / DIMENSIONS MEDIDA	EMBALAGEM QUANTITY / EMBALLAGE / EMBALAJE
799132040080	M4X8	1000
799132040100	M4X10	1000
799132040160	M4X16	1000
799132040200	M4X20	500
799132050120	M5X12	1000
799132050160	M5X16	500
799132050200	M5X20	500
799132050300	M5X30	500
799132060120	M6X12	500
799132060160	M6X16	500
799132060200	M6X20	500
799132060250	M6X25	500
799132060300	M6X30	200
799132060350	M6X35	200
799132060450	M6X45	200
799132060500	M6X50	200
799132060600	M6X60	200
799132060700	M6X70	200
799132080200	M8X20	200
799132080250	M8X25	200

CÓDIGO CODE / CODE / CÓDIGO	DIMENSÕES SIZE / DIMENSIONS MEDIDA	EMBALAGEM QUANTITY / EMBALLAGE / EMBALAJE
799132080300	M8X30	200
799132080350	M8X35	200
799132080400	M8X40	200
799132080450	M8X45	200
799132080500	M8X50	100
799132080550	M8X55	100
799132080600	M8X60	100
799132080800	M8X80	100
799132080900	M8X90	100
799132081000	M8X100	100
799132100250	M10X25	200
799132100300	M10X30	200
799132100350	M10X35	100
799132100400	M10X40	100
799132100500	M10X50	100
799132100600	M10X60	100
799132100700	M10X70	50
799132120300	M12X30	100
799132120400	M12X40	100
799132120500	M12X50	100



ACABAMENTOS  
FINISHES / FINITIONS / ACABADOS



MAIS MEDIDAS  
DISPONÍVEIS EM GAMA  
MORE MEASUREMENTS AVAILABLE IN RANGE  
/ PLUS DE MESURES DISPONIBLES DANS LA GAMME  
/ MÁS MEDIDAS DISPONIBLES EN GAMA

## Parafuso Rosca de Metais Cabeça Embeber Phillips

Cross recessed countersunk head screw, zinc plated / Vis à métaux tête fraisée à empreinte cruciforme, zingué  
/ Tornillo cabeza avellanada con hueco cruciforme, zincado

# DIN 965

Zincado / Zingué / Zinc Plated / Zincado

DIN 965



CÓDIGO CODE / CODE / CÓDIGO	DIMENSÕES SIZE / DIMENSIONS MEDIDA	EMBALAGEM QUANTITY / EMBALLAGE / EMBALAJE
096512030080	M3X8	1000
096512030100	M3X10	1000
096512030160	M3X16	1000
096512030250	M3X25	1000
096512040080	M4X8	1000
096512040100	M4X10	1000
096512040120	M4X12	1000
096512040140	M4X14	1000
096512040160	M4X16	1000
096512040200	M4X20	500
096512040250	M4X25	500
096512040300	M4X30	500
096512040400	M4X40	500
096512040500	M4X50	500
096512040550	M4X55	500
096512050100	M5X10	1000
096512050120	M5X12	1000
096512050160	M5X16	500
096512050200	M5X20	500
096512050250	M5X25	500
096512050300	M5X30	500
096512050350	M5X35	200

CÓDIGO CODE / CODE / CÓDIGO	DIMENSÕES SIZE / DIMENSIONS MEDIDA	EMBALAGEM QUANTITY / EMBALLAGE / EMBALAJE
096512050400	M5X40	200
096512050450	M5X45	200
096512050500	M5X50	200
096512050600	M5X60	200
096512050700	M5X70	200
096512050750	M5X75	200
096512050850	M5X85	100
096512060100	M6X10	500
096512060160	M6X16	500
096512060200	M6X20	500
096512060250	M6X25	500
096512060300	M6X30	200
096512060350	M6X35	200
096512060400	M6X40	200
096512060450	M6X45	200
096512060500	M6X50	200
096512060600	M6X60	200
096512080160	M8X16	200
096512080200	M8X20	200
096512080350	M8X35	200
096512080400	M8X40	200
096512080500	M8X50	100



ACABAMENTOS  
FINISHES / FINITIONS / ACABADOS



MAIS MEDIDAS  
DISPONÍVEIS EM GAMA  
MORE MEASUREMENTS AVAILABLE IN RANGE  
/ PLUS DE MESURES DISPONIBLES DANS LA GAMME  
/ MÁS MEDIDAS DISPONIBLES EN GAMA

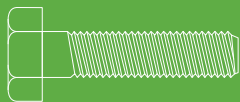

# PARAFUSOS ROSCA MÉTRICA

Metric thread screw / Vis filet métrique / Tornillos rosca métrica

## DIN 7985

### Parafuso Rosca de Metais Cabeça de Queijo Phillips

Phillips pan head machine screw / Vis à tête cylindrique bombée empreite cruciforme / Tornillo de cabeza cilíndrica abombada con hueco cruciforme

DIN 7985

Zincado / Zinc Plated / Zingué / Zincado



#### ACABAMENTOS FINISHES / FINITIONS / ACABADOS



**MAIS MEDIDAS  
DISPONÍVEIS EM GAMA**  
MORE MEASUREMENTS AVAILABLE IN RANGE  
/ PLUS DE MESURES DISPONIBLES DANS LA GAMME  
/ MÁS MEDIDAS DISPONIBLES EN GAMA

CÓDIGO CODE / CODE / CÓDIGO	DIMENSÕES SIZE / DIMENSIONS MEDIDA	EMBALAGEM QUANTITY / EMBALLAGE / EMBALAJE
798512030050	M3X5	1000
798512030060	M3X6	1000
798512030080	M3X8	1000
798512030100	M3X10	1000
798512030120	M3X12	1000
798512030160	M3X16	1000
798512040060	M4X6	1000
798512040080	M4X8	1000
798512040100	M4X10	1000
798512040120	M4X12	1000
798512040160	M4X16	1000
798512040200	M4X20	500
798512040400	M4X40	500
798512040450	M4X45	500
798512050060	M5X6	1000
798512050080	M5X8	1000
798512050100	M5X10	1000
798512050120	M5X12	1000
798512050160	M5X16	500
798512050200	M5X20	500

CÓDIGO CODE / CODE / CÓDIGO	DIMENSÕES SIZE / DIMENSIONS MEDIDA	EMBALAGEM QUANTITY / EMBALLAGE / EMBALAJE
798512050300	M5X30	500
798512050450	M5X45	200
798512050550	M5X55	200
798512060080	M6X8	500
798512060100	M6X10	500
798512060120	M6X12	500
798512060160	M6X16	500
798512060200	M6X20	500
798512060250	M6X25	500
798512060300	M6X30	200
798512060350	M6X35	200
798512060400	M6X40	200
798512060450	M6X45	200
798512060500	M6X50	200
798512060600	M6X60	200
798512080120	M8X12	200
798512080160	M8X16	200
798512080350	M8X35	200
798512080450	M8X45	200
798512080500	M8X50	100

## DIN 603

### Parafuso Arreigada Quadrada Cabeça Oval

Mushroom head square neck bolt / Vis à métaux tête ronde collet carré / Tornillos de cabeza abombada y cuello cuadrado

DIN 603

Zincado / Zinc Plated / Zingué / Zincado



#### ACABAMENTOS FINISHES / FINITIONS / ACABADOS



**MAIS MEDIDAS  
DISPONÍVEIS EM GAMA**  
MORE MEASUREMENTS AVAILABLE IN RANGE  
/ PLUS DE MESURES DISPONIBLES DANS LA GAMME  
/ MÁS MEDIDAS DISPONIBLES EN GAMA

CÓDIGO CODE / CODE / CÓDIGO	DIMENSÕES SIZE / DIMENSIONS MEDIDA	EMBALAGEM QUANTITY / EMBALLAGE / EMBALAJE
060312050160	M5X16	500
060312050300	M5X30	500
060312050350	M5X35	200
060312050400	M5X40	200
060312050500	M5X50	200
060312060120	M6X12	500
060312060160	M6X16	500
060312060200	M6X20	500
060312060250	M6X25	500
060312060300	M6X30	200
060312060350	M6X35	200
060312060400	M6X40	200
060312060450	M6X45	200
060312060500	M6X50	200
060312060550	M6X55	200
060312060600	M6X60	200
060312060700	M6X70	100
060312060800	M6X80	100
060312060900	M6X90	100
060312080160	M8X16	200
060312080200	M8X20	200
060312080250	M8X25	200
060312080300	M8X30	200
060312080350	M8X35	200

CÓDIGO CODE / CODE / CÓDIGO	DIMENSÕES SIZE / DIMENSIONS MEDIDA	EMBALAGEM QUANTITY / EMBALLAGE / EMBALAJE
060312080400	M8X40	200
060312080450	M8X45	200
060312080500	M8X50	100
060312080600	M8X60	100
060312080700	M8X70	100
060312080800	M8X80	100
060312080850	M8X85	100
060312080900	M8X90	100
060312081000	M8X100	100
060312081100	M8X110	50
060312081200	M8X120	50
060312100250	M10X25	200
060312100300	M10X30	100
060312100350	M10X35	100
060312100400	M10X40	100
060312100600	M10X60	100
060312100650	M10X65	100
060312100800	M10X80	50
060312100900	M10X90	50
060312101000	M10X100	50
060312101200	M10X120	50
060312101300	M10X130	50
060312101400	M10X140	50

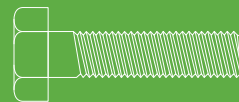

## Varão Roscado **DIN 975**

Threaded rod / Tige filetée / Varrila roscado

Zincado / Zingué / Zinc Plated / **Zincado** **DIN 975**



CÓDIGO CODE / CODE / CÓDIGO	DIMENSÕES SIZE / DIMENSIONS MEDIDA	EMBALAGEM QUANTITY / EMBALLAGE / EMBALAJE
097512031000	M3x1000	1
097512041000	M4x1000	1
097512051000	M5x1000	1
097512061000	M6x1000	1
097512062000	M6x2000	1
097512063000	M6x3000	1
097512081000	M8x1000	1
097512082000	M8x2000	1
097512083000	M8x3000	1
097512101000	M10x1000	1
097512102000	M10x2000	1
097512103000	M10x3000	1
097512121000	M12x1000	1
097512122000	M12x2000	1
097512123000	M12x3000	1
097512141000	M14x1000	1

CÓDIGO CODE / CODE / CÓDIGO	DIMENSÕES SIZE / DIMENSIONS MEDIDA	EMBALAGEM QUANTITY / EMBALLAGE / EMBALAJE
097512161000	M16x1000	1
097512162000	M16x2000	1
097512163000	M16x3000	1
097512181000	M18x1000	1
097512201000	M20x1000	1
097512221000	M22x1000	1
097512223000	M22x3000	1
097512241000	M24x1000	1
097512271000	M27x1000	1
097512301000	M30x1000	1
097512331000	M33x1000	1
097512361000	M36x1000	1
097512391000	M39x1000	1
097512421000	M42x1000	1
097512451000	M45x1000	1
097512481000	M48x1000	1



**ACABAMENTOS**  
FINISHES / FINITIONS / ACABADOS

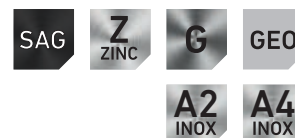

**MAIS MEDIDAS**  
**DISPONÍVEIS EM GAMA**  
MORE MEASUREMENTS AVAILABLE IN RANGE  
/ PLUS DE MESURES DISPONIBLES DANS LA GAMME  
/ MÁS MEDIDAS DISPONIBLES EN GAMA

## Porca Sextavada de Rosca Métrica **DIN 934**

Hexagon nuts metric thread / Écrou hexagonal à filetage métrique / Tuerca hexagonal rosca métrica

Zincado / Zingué / Zinc Plated / **Zincado** **DIN 965**



CÓDIGO CODE / CODE / CÓDIGO	DIMENSÕES SIZE / DIMENSIONS MEDIDA	EMBALAGEM QUANTITY / EMBALLAGE / EMBALAJE
093422030000D	M3	1000
093422040000D	M4	1000
093422050000D	M5	1000
093422060000D	M6	1000
093422070000D	M7	1000
093422080000D	M8	500
093422100000D	M10	200
093422120000D	M12	200
093422140000D	M14	100
093422160000D	M16	100
093422180000D	M18	100
093422200000D	M20	50
093422220000D	M22	50

CÓDIGO CODE / CODE / CÓDIGO	DIMENSÕES SIZE / DIMENSIONS MEDIDA	EMBALAGEM QUANTITY / EMBALLAGE / EMBALAJE
093422240000D	M24	50
093422270000D	M27	25
093422300000D	M30	25
093422330000D	M33	20
093422360000D	M36	10
093422390000D	M39	10
093422420000D	M42	10
093422450000D	M45	5
093422480000D	M48	5
093422520000D	M52	5
093422560000D	M56	5
093422600000D	M60	5



**ACABAMENTOS**  
FINISHES / FINITIONS / ACABADOS



**MAIS MEDIDAS**  
**DISPONÍVEIS EM GAMA**  
MORE MEASUREMENTS AVAILABLE IN RANGE  
/ PLUS DE MESURES DISPONIBLES DANS LA GAMME  
/ MÁS MEDIDAS DISPONIBLES EN GAMA

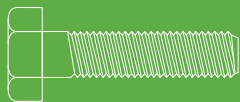

# PARAFUSOS ROSCA MÉTRICA

Metric thread screw / Vis filet métrique / Tornillos rosca métrica

## DIN 985

### Porca Sextavada Nyloc

Prevailing torque type hexagon nut with non-metallic insert / Écrou à frein hexagonal bague nylon bas / Tuerca hexagonal de seguridad con arandella plástica

DIN 985

Zincado / Zinc Plated / Zingué / Zincado



CÓDIGO CODE / CODE / CÓDIGO	DIMENSÕES SIZE / DIMENSIONS MEDIDA	EMBALAGEM QUANTITY / EMBALLAGE / EMBALAJE	CÓDIGO CODE / CODE / CÓDIGO	DIMENSÕES SIZE / DIMENSIONS MEDIDA	EMBALAGEM QUANTITY / EMBALLAGE / EMBALAJE
098522030000	M3	1000	098522220000	M22	50
098522040000	M4	1000	098522240000	M24	25
098522060000	M6	1000	098522270000	M27	25
098522070000	M7	500	098522300000	M30	25
098522080000	M8	500	098522330000	M33	20
098522100000	M10	200	098522360000	M36	10
098522120000	M12	200	098522390000	M39	10
098522140000	M14	100	098522420000	M42	10
098522160000	M16	100	098522450000	M45	5
098522180000	M18	100	098522520000	M52	5
098522200000	M20	50			

ACABAMENTOS  
FINISHES / FINITIONS / ACABADOS



MAIS MEDIDAS DISPONÍVEIS EM GAMA

MORE MEASUREMENTS AVAILABLE IN RANGE / PLUS DE MESURES DISPONIBLES DANS LA GAMME / MÁS MEDIDAS DISPONIBLES EN GAMA

## DIN 6923

### Porca Sextavada com False Anilha e Recartilha

Hexagon flange knurled nut / Écrou hexagonal à embase cylindrique / Tuerca hexagonal con collar biselado

DIN 6923

Zincado / Zinc Plated / Zingué / Zincado



CÓDIGO CODE / CODE / CÓDIGO	DIMENSÕES SIZE / DIMENSIONS MEDIDA	EMBALAGEM QUANTITY / EMBALLAGE / EMBALAJE	CÓDIGO CODE / CODE / CÓDIGO	DIMENSÕES SIZE / DIMENSIONS MEDIDA	EMBALAGEM QUANTITY / EMBALLAGE / EMBALAJE
692312030000	M3	1000	692312080000	M8	500
692312040000	M4	1000	692312100000	M10	200
692312050000	M5	1000	692312120000	M12	200
692312060000	M6	1000	692312160000	M16	100

ACABAMENTOS  
FINISHES / FINITIONS / ACABADOS



MAIS MEDIDAS DISPONÍVEIS EM GAMA

MORE MEASUREMENTS AVAILABLE IN RANGE / PLUS DE MESURES DISPONIBLES DANS LA GAMME / MÁS MEDIDAS DISPONIBLES EN GAMA

## DIN 127

### Anilha de Mola

Spring lock washers with square ends / Rondelle élastique / Arandela helicoidal de presion

DIN 127

Zincado / Zinc Plated / Zingué / Zincado



CÓDIGO CODE / CODE / CÓDIGO	DIMENSÕES SIZE / DIMENSIONS MEDIDA	EMBALAGEM QUANTITY / EMBALLAGE / EMBALAJE	CÓDIGO CODE / CODE / CÓDIGO	DIMENSÕES SIZE / DIMENSIONS MEDIDA	EMBALAGEM QUANTITY / EMBALLAGE / EMBALAJE
012722030000	M3	1000	012722180000	M18	100
012722040000	M4	1000	012722200000	M20	100
012722050000	M5	1000	012722220000	M22	50
012722060000	M6	1000	012722240000	M24	50
012722070000	M7	1000	012722270000	M27	25
012722080000	M8	1000	012722300000	M30	25
012722100000	M10	500	012722330000	M33	25
012722120000	M12	500	012722360000	M36	25
012722140000	M14	200	012722390000	M39	25
012722160000	M16	200	012722420000	M42	10

ACABAMENTOS  
FINISHES / FINITIONS / ACABADOS



MAIS MEDIDAS DISPONÍVEIS EM GAMA

MORE MEASUREMENTS AVAILABLE IN RANGE / PLUS DE MESURES DISPONIBLES DANS LA GAMME / MÁS MEDIDAS DISPONIBLES EN GAMA

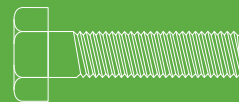

## Anilha de Chapa **DIN 125**

Flat washer / Rondelle plate / Arandela plana

Zincado / Zingú / Zinc Plated / Zincado **DIN 125**



CÓDIGO CODE / CODE / CÓDIGO	DIMENSÕES SIZE / DIMENSIONS MEDIDA	EMBALAGEM QUANTITY / EMBALLAGE / EMBALAJE
012512020000	M2	1000
012512030000	M3	1000
012512040000	M4	1000
012512050000	M5	1000
012512060000	M6	1000
012512070000	M7	1000
012512080000	M8	1000
012512100000	M10	500
012512120000	M12	250
012512140000	M14	250
012512160000	M16	200
012512180000	M18	200
012512200000	M20	200

CÓDIGO CODE / CODE / CÓDIGO	DIMENSÕES SIZE / DIMENSIONS MEDIDA	EMBALAGEM QUANTITY / EMBALLAGE / EMBALAJE
012512220000	M22	100
012512240000	M24	50
012512270000	M27	50
012512300000	M30	50
012512330000	M33	25
012512360000	M36	25
012512390000	M39	25
012512420000	M42	10
012512450000	M45	10
012512480000	M48	10
012512520000	M52	10
012512560000	M56	10

**MAIS MEDIDAS DISPONÍVEIS EM GAMA**  
MORE MEASUREMENTS AVAILABLE IN RANGE / PLUS DE MESURES  
DISPONIBLES DANS LA GAMME/ MÁS MEDIDAS DISPONIBLES EN GAMA



**ACABAMENTOS**  
FINISHES / FINITIONS / ACABADOS

## Anilha Aba Larga **DIN 9021**

Flat washer / Rondelle plate large / Arandela plana ala ancha

Zincado / Zingú / Zinc Plated / Zincado **DIN 9021**



CÓDIGO CODE / CODE / CÓDIGO	DIMENSÕES SIZE / DIMENSIONS MEDIDA	EMBALAGEM QUANTITY / EMBALLAGE / EMBALAJE
902112030000	M3	1000
902112040000	M4	1000
902112050000	M5	1000
902112060000	M6	500
902112080000	M8	500
902112100000	M10	250
902112120000	M12	200
902112140000	M14	100

CÓDIGO CODE / CODE / CÓDIGO	DIMENSÕES SIZE / DIMENSIONS MEDIDA	EMBALAGEM QUANTITY / EMBALLAGE / EMBALAJE
902112160000	M16	100
902112180000	M18	50
902112200000	M20	50
902112220000	M22	25
902112240000	M24	25
902112270000	M27	25
902112300000	M30	25

**MAIS MEDIDAS DISPONÍVEIS EM GAMA**  
MORE MEASUREMENTS AVAILABLE IN RANGE / PLUS DE MESURES  
DISPONIBLES DANS LA GAMME/ MÁS MEDIDAS DISPONIBLES EN GAMA



**ACABAMENTOS**  
FINISHES / FINITIONS / ACABADOS



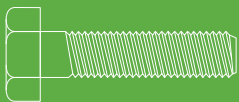

# PARAFUSOS ROSCA MÉTRICA

Metric thread screw / Vis filet métrique / Tornillos rosca métrica

## GAMA DISPONÍVEL

/ Available range / Gamme disponible / Gama disponible

### PARAFUSOS CABEÇA HEXAGONAL

/ HEXAGONAL BOLTS  
/ VIS A TÊTE HEXAGONAL  
/ TORNILLOS CABEÇA HEXAGONAL



### PORCAS

NUT  
/ ÉCROU  
/ TUERCAS



### PARAFUSOS ROSCA METAIS

/ SELF THREADING SCREWS  
/ VIS POUR METAUX  
/ TORNILLOS ROSCA METAL



### PARAFUSOS ALLEN

/ ALLEN BOLTS  
/ SIX PANS CREUX  
/ TORNILLOS ALLEN













### VARÃO ROSCADO

/ THREADED ROD  
/ TIGE FILETÉE  
/ VARILLA ROSCADA





**GAMA DISPONÍVEL** / Available range / Gamme disponible / Gama disponible

 DIN 936	 DIN 6334	 PCL 934 <small>Sentavado Interior</small>	 DIN 137 A	 DIN 6796 A	 DIN 9021 <small>ISO 7093</small>
 DIN 980 V	 EN 14399-4	 PCL 934 <small>FENDA</small>	 DIN 433	 DIN 6797 J	 PCL 125 <small>NFE 25-511</small>
 DIN 985	 DIN 7967	 PCL 941	 DIN 434	 DIN 6798 A	 PCL 0001
 DIN 986	 DIN 982	 PCL 935	 DIN 440 R	 DIN 6798 J	 PCL 0001
 DIN 1587	 PCL 1934 UNC	 PCL 6919	 DIN 471	 DIN 6799	 PCL 0002
 UNI 5587	 PCL 1934	<b>ANILHAS</b> / WASHERS / RONDELLES / ARANDELAS		 DIN 472	 EN 14399-6
 DIN 6923	 PCL 2934 UNF	 DIN 125 <small>ISO 7980</small>	 DIN 2093	 DIN 7980	<p><b>CATÁLOGO TÉCNICO</b> FIXING CATALOGUE / CATALOGUE TECHNIQUE / CATALOGO TÉCNICO</p>  
 DIN 6331	 PCL 315	 DIN 127	 DIN 6796	 DIN 7989	

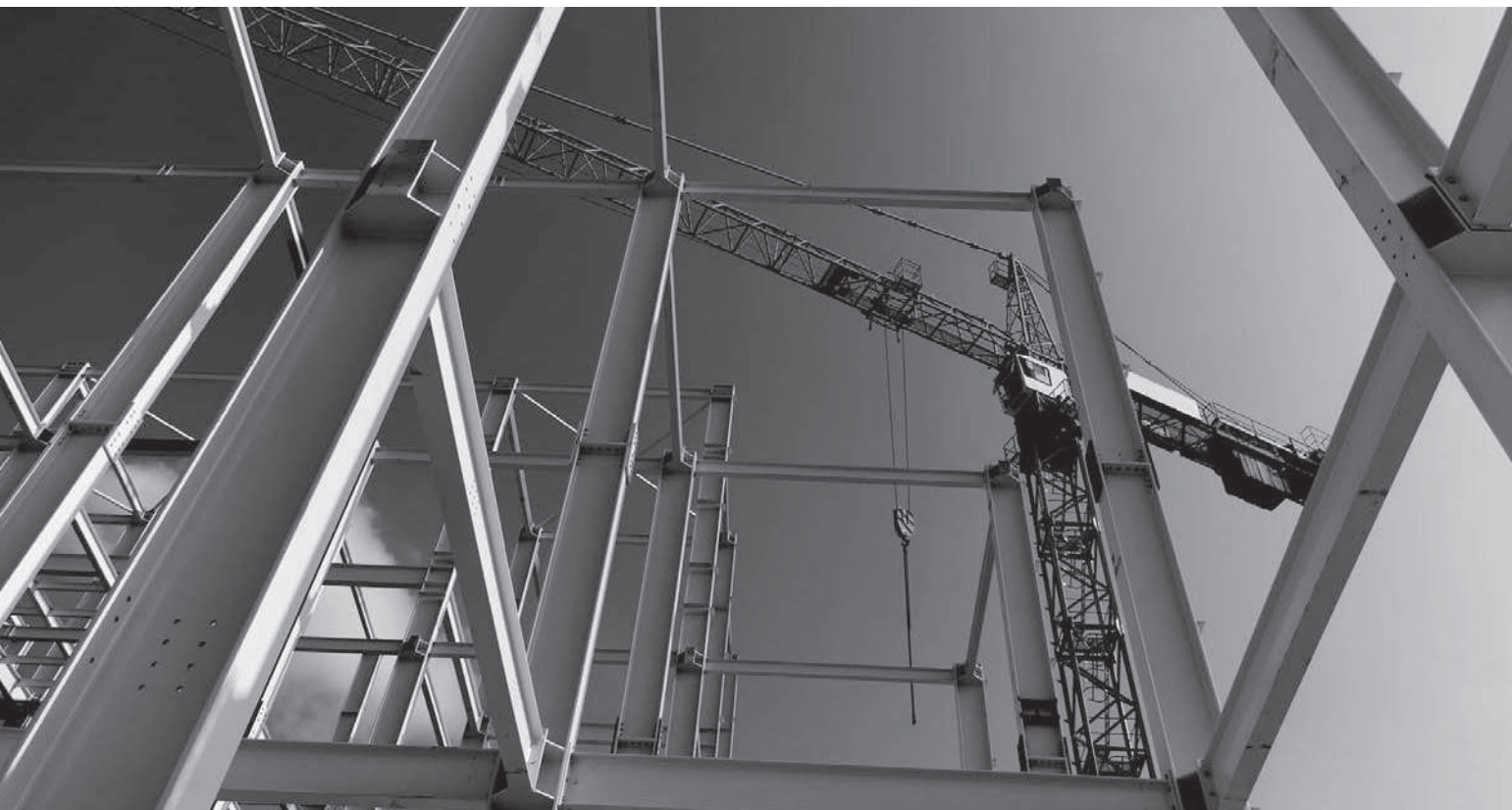



**O SEU FORNECEDOR DE SEMPRE,  
ONDE ESTIVER!**

*/ Your ever-ready supplier, wherever you are! / Votre fournisseur de  
toujours, où que vous soyez! / Su proveedor de siempre, donde esté!*

[HTTP://STORE.PECOL.PT/](http://store.pecol.pt/)

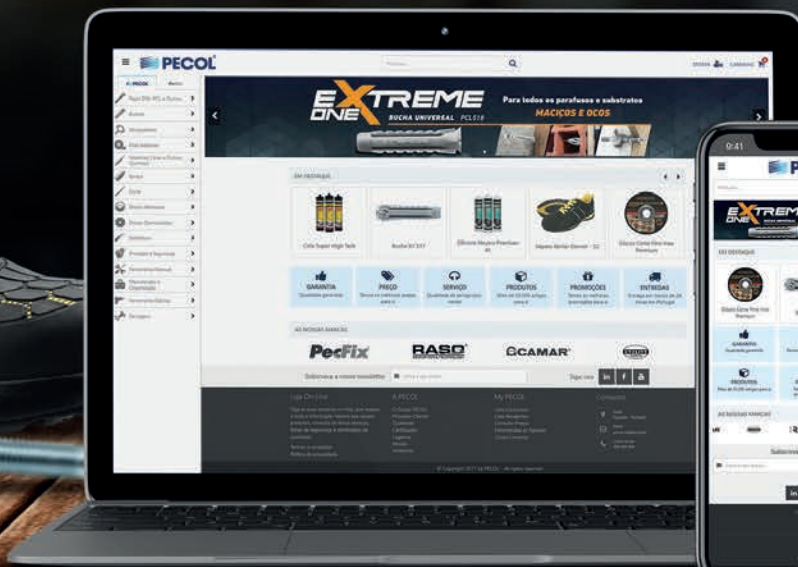





# **PARAFUSOS AUTO-PERFURANTES E AUTO-ROSCANTES**

*DRILL AND TAPPING SCREWS*

*VIS AUTOPERCEUSE ET VIS À TÔLE*

*TORNILLO AUTOTALADRAR Y AUTOROSCANTE*

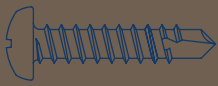

# PARAFUSOS AUTO-PERFURANTES E AUTO-ROSCANTES

Drill and Tapping Screws / Vis autoperceuse et Vis à Tôle / Tornillo autotaladrar y Autoroscante

## DIN 7504-K

### Parafuso Auto-Perfurante Cabeça Sextavada

Self-drilling screw with hexagon washer head / Vis autoperceuse, tête hexagonale avec collerette estampée / Tornillo autotaladrante de cabeça hexagonal con arandela estampada

DIN 7504-K

Parafuso / Screw / Vis / Tornillo





CÓDIGO CODE / CODE / CÓDIGO	DIMENSÕES SIZE / DIMENSIONS MEDIDA		EMBALAGEM QUANTITY / EMBALLAGE / EMBALAJE	CÓDIGO CODE / CODE / CÓDIGO	DIMENSÕES SIZE / DIMENSIONS MEDIDA		EMBALAGEM QUANTITY / EMBALLAGE / EMBALAJE
976022060100	3,5 x 9,5	6	1000	976022550500	5,5 x 50	8	500
976022060130	3,5 x 13	6	1000	976022550600	5,5 x 60	8	500
976022420130	4,2 x 13	7	1000	976022630160	6,3 x 16	10	500
976022420160	4,2 x 16	7	1000	976022630200	6,3 x 20	10	500
976022420190	4,2 x 19	7	1000	976022630250	6,3 x 25	10	500
976022420250	4,2 x 25	7	1000	976022630320	6,3 x 32	10	500
976022420320	4,2 x 32	7	1000	976022630400	6,3 x 40	10	250
976022480130	4,8 x 13	8	1000	976022630500	6,3 x 50	10	250
976022480160	4,8 x 16	8	1000	976022630600	6,3 x 60	10	200
976022480190	4,8 x 19	8	1000	976022630700	6,3 x 70	10	200
976022480250	4,8 x 25	8	1000	976022630760	6,3 x 76	10	200
976022480320	4,8 x 32	8	1000	976022630900	6,3 x 90	10	100
976022480380	4,8 x 38	8	500	976022631000	6,3 x 100	10	100
976022550190	5,5 x 19	8	1000	976022631100	6,3 x 110	10	100
976022550220	5,5 x 22	8	500	976022631200	6,3 x 120	10	100
976022550250	5,5 x 25	8	500	976022631300	6,3 x 130	10	100
976022550320	5,5 x 32	8	500	976022631400	6,3 x 140	10	100
976022550380	5,5 x 38	8	500				

Mais medidas, matérias primas e acabamentos disponíveis em gama / More measurements, raw materials and finishes available in range / Plus de mesures, de matières premières et de finitions disponibles dans la gamme / Más medidas, materias primas y acabados disponibles en gama

DIN 7504-K

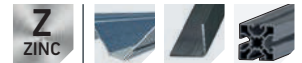
Broca Fina / Reduced drill point / Pointe foreuse / Punta reducida



CÓDIGO CODE / CODE / CÓDIGO	DIMENSÕES SIZE / DIMENSIONS MEDIDA		EMBALAGEM QUANTITY / EMBALLAGE / EMBALAJE
976022480191	4,8 x 19	8	500
976022630251	6,3 x 25	10	500

Mais medidas, matérias primas e acabamentos disponíveis em gama / More measurements, raw materials and finishes available in range / Plus de mesures, de matières premières et de finitions disponibles dans la gamme / Más medidas, materias primas y acabados disponibles en gama

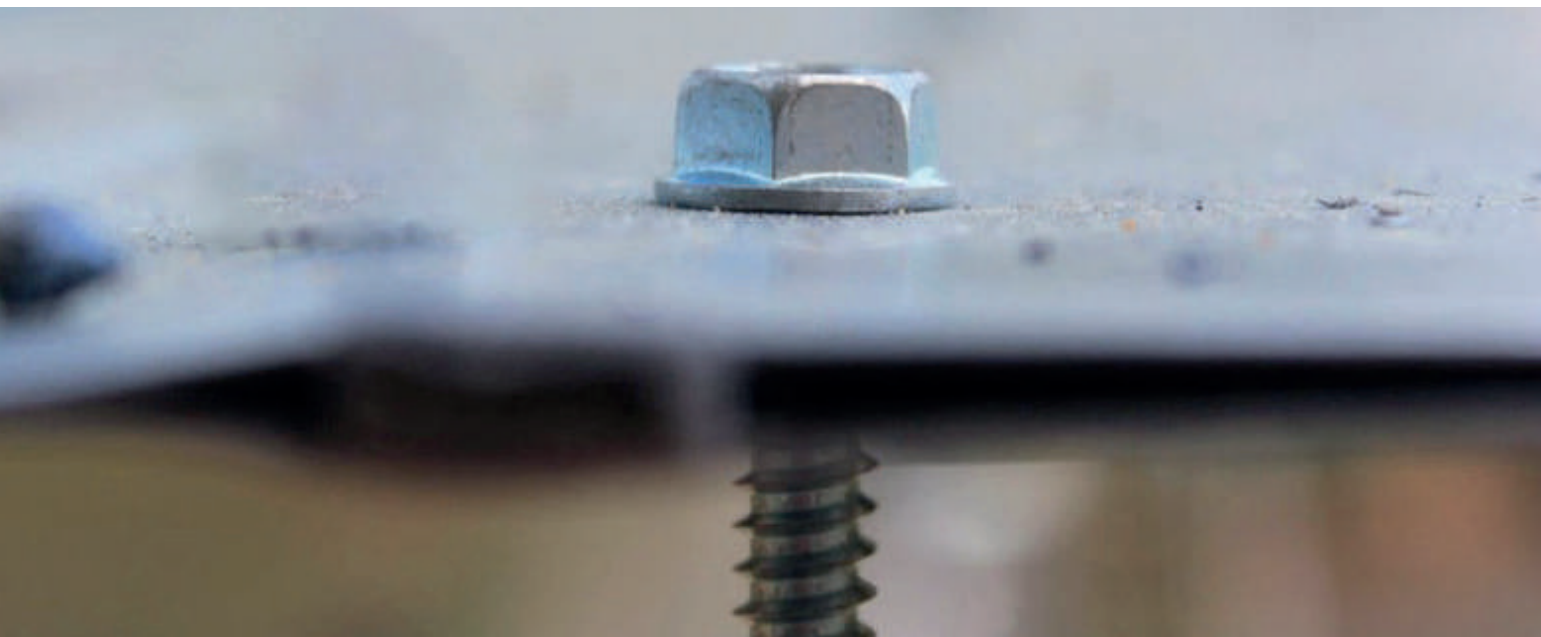

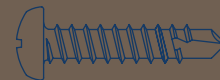



Tornillo con Arandela EPDM / Vis avec Rondelle EPDM / Screw with EPDM Washer / Parafuso com Anilha EPDM

PCL9761



CÓDIGO CODE / CODE / CÓDIGO	DIMENSÕES SIZE / DIMENSIONS MEDIDA		EMBALAGEM QUANTITY / EMBALLAGE / EMBALAJE	CÓDIGO CODE / CODE / CÓDIGO	DIMENSÕES SIZE / DIMENSIONS MEDIDA		EMBALAGEM QUANTITY / EMBALLAGE / EMBALAJE
976122480160	4,8 x 16 P14	8	500	976122550221	6,3 x 130 P18	10	100
976122480190	4,8 x 19 P14	8	500	976122550251	6,3 x 140 P18	10	100
976122480250	4,8 x 25 P14	8	500	976122550381	6,3 x 160 P18	10	50
976122480320	4,8 x 32 P14	8	500	976122550501	5,5 x 20 P25	8	250
976122480380	4,8 x 38 P14	8	500	976122550601	5,5 x 22 P25	8	250
976122550200	5,5 x 20 P16	8	500	976122630201	5,5 x 25 P25	8	250
976122550220	5,5 x 22 P16	8	500	976122630251	5,5 x 38 P25	8	250
976122550250	5,5 x 25 P16	8	500	976122630321	5,5 x 50 P25	8	250
976122550320	5,5 x 32 P16	8	500	976122630401	5,5 x 60 P25	8	200
976122550380	5,5 x 38 P16	8	500	976122630501	6,3 x 20 P25	10	250
976122550500	5,5 x 50 P16	8	250	976122630601	6,3 x 25 P25	10	250
976122550600	5,5 x 60 P16	8	250	976122630701	6,3 x 32 P25	10	250
976122630200	6,3 x 20 P18	10	250	976122630761	6,3 x 40 P25	10	250
976122630220	6,3 x 22 P18	10	250	976122630901	6,3 x 50 P25	10	200
976122630250	6,3 x 25 P18	10	250	976122631001	6,3 x 60 P25	10	200
976122630320	6,3 x 32 P18	10	250	976122631101	6,3 x 70 P25	10	100
976122630400	6,3 x 40 P18	10	250	976122631201	6,3 x 76 P25	10	100
976122630500	6,3 x 50 P18	10	250	976122631301	6,3 x 90 P25	10	100
976122630600	6,3 x 60 P18	10	200	976122631401	6,3 x 100 P25	10	100
976122630700	6,3 x 70 P18	10	200	976122631601	6,3 x 110 P25	10	100
976122630760	6,3 x 76 P18	10	100	976122631201	6,3 x 120 P25	10	50
976122631300	6,3 x 90 P18	10	100	976122631301	6,3 x 130 P25	10	50
976122631400	6,3 x 100 P18	10	100	976122631401	6,3 x 140 P25	10	50
976122631600	6,3 x 110 P18	10	100	976122631601	6,3 x 160 P25	10	50
976122550201	6,3 x 120 P18	10	100				



Mais medidas, matérias primas e acabamentos disponíveis em gama / More measurements, raw materials and finishes available in range / Plus de mesures, de matières premières et de finitions disponibles dans la gamme / Más medidas, materias primas y acabados disponibles en gama

Punta reducida con arandela EPDM / Pointe foreuse avec rondelle EPDM / Reduced drill point with EPDM washer / Broca Fina com Anilha EPDM

PCL9761

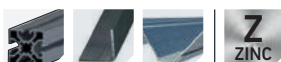

CÓDIGO CODE / CODE / CÓDIGO	DIMENSÕES SIZE / DIMENSIONS MEDIDA		EMBALAGEM QUANTITY / EMBALLAGE / EMBALAJE
976122480192	4,8 x 19 P14	8	500
976122630252	6,3 x 25 P18	10	250



Mais medidas, matérias primas e acabamentos disponíveis em gama / More measurements, raw materials and finishes available in range / Plus de mesures, de matières premières et de finitions disponibles dans la gamme / Más medidas, materias primas y acabados disponibles en gama

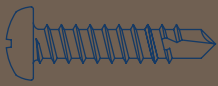

# PARAFUSOS AUTO-PERFURANTES E AUTO-ROSCANTES

Drill and Tapping Screws / Vis autoperceuse et Vis à Tôle / Tornillo autotaladrar y Autoroscante

## DIN 7504-N

### Parafuso Auto-Perfurante Cabeça de Queijo Phillips

Self-drilling screw with panhead, Phillips recess / Vis autoperceuse, pointe foreuse, tête cylindrique bombée, Phillips / Tornillo autotaladrante de cabeza alomada y huella Phillips

DIN 7504-N

Aço Inox A2 / Stainless Steel A2 / Inoxydable A2 / Inoxidable A2

A2  
INOX

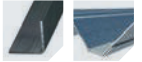

CÓDIGO CODE / CODE / CÓDIGO	DIMENSÕES SIZE / DIMENSIONS MEDIDA		ESP. MAX A FIXAR MAX FIXTURE THICKNESS / ÉPAISSEUR MAX À FIXER/ ESP. MÁX A FIJAR	CAPACIDADE DE PERFURAÇÃO DRILL CAPACITY / CAPACITÉ DE PERÇADE / CAPACIDAD DE TALADRADO	EMBALAGEM QUANTITY / EMBALLAGE / EMBALAJE
981061060130	3,5 x 13	PH2	6,85	2,25	1000
981061060160	3,5 x 16	PH2	9,85	2,25	1000
981061070130	3,9 x 13	PH2	6,69	2,4	500
981061070190	3,9 x 19	PH2	12,70	2,4	1000
981061070250	3,9 x 25	PH2	18,70	2,4	1000
981061080130	4,2 x 13	PH2	5,80	3	1000
981061080160	4,2 x 16	PH2	8,80	3	1000
981061080190	4,2 x 19	PH2	11,8	3	1000
981061080250	4,2 x 25	PH2	17,8	3	500
981061080380	4,2 x 38	PH2	30,8	3	500
981061100130	4,8 x 13	PH2	5,80	3	1000
981061100190	4,8 x 19	PH2	9,79	4,40	1000
981061100250	4,8 x 25	PH2	15,8	4,40	500
981061100380	4,8 x 38	PH2	28,8	4,40	500
981061100450	4,8 x 45	PH2	35,79	4,40	500
981061100500	4,8 x 50	PH2	40,79	4,40	500
981061100630	4,8 x 63	PH2	53,79	4,40	200

Mais medidas, matérias primas e acabamentos disponíveis em gama / More measurements, raw materials and finishes available in range / Plus de mesures, de matières premières et de finitions disponibles dans la gamme / Más medidas, materias primas y acabados disponibles en gama



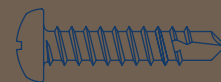

**Z**  
ZINC



CÓDIGO CODE / CODE / CÓDIGO	DIMENSÕES SIZE / DIMENSIONS MEDIDA		ESP. MAX A FIXAR MAX FIXTURE THICKNESS / ÉPAISSEUR MAX À FIXER/ ESP. MAX A FIJAR	CAPACIDADE DE PERFURAÇÃO DRILL CAPACITY / CAPACITÉ DE PERÇADE / CAPACIDAD DE TALADRADO	EMBALAGEM QUANTITY / EMBALLAGE / EMBALAJE
981022040100	2,9 x 9,5	PH1	4,10	2	1000
981022040130	2,9 x 13	PH1	7,10	2	1000
981022040160	2,9 x 16	PH1	10,10	2	1000
981022040190	2,9 x 19	PH1	13,10	2	1000
981022060100	3,5 x 9,5	PH2	3,85	2,25	1000
981022060130	3,5 x 13	PH2	6,85	2,25	1000
981022060160	3,5 x 16	PH2	9,85	2,25	1000
981022060190	3,5 x 19	PH2	12,85	2,25	1000
981022060220	3,5 x 22	PH2	15,85	2,25	1000
981022060250	3,5 x 25	PH2	18,85	2,25	1000
981022070130	3,9 x 13	PH2	6,69	2,4	1000
981022070160	3,9 x 16	PH2	9,69	2,4	1000
981022070190	3,9 x 19	PH2	12,70	2,4	1000
981022070220	3,9 x 22	PH2	15,70	2,4	1000
981022070250	3,9 x 25	PH2	18,70	2,4	1000
981022070320	3,9 x 32	PH2	25,70	2,4	1000
981022080130	4,2 x 13	PH2	5,80	3	1000
981022080160	4,2 x 16	PH2	8,80	3	1000
981022080190	4,2 x 19	PH2	11,8	3	1000
981022080220	4,2 x 22	PH2	14,8	3	1000
981022080250	4,2 x 25	PH2	17,8	3	1000
981022080320	4,2 x 32	PH2	24,8	3	1000
981022080380	4,2 x 38	PH2	30,8	3	1000
981022100130	4,8 x 13	PH2	5,80	3	1000
981022100160	4,8 x 16	PH2	6,79	4,40	1000
981022100190	4,8 x 19	PH2	9,79	4,40	1000
981022100250	4,8 x 25	PH2	15,8	4,40	1000
981022100320	4,8 x 32	PH2	22,8	4,40	500
981022100380	4,8 x 38	PH2	28,8	4,40	500
981022100450	4,8 x 45	PH2	35,8	4,40	500
981022100500	4,8 x 50	PH2	40,79	4,40	500
981022100630	4,8 x 63	PH2	53,79	4,40	250
981022100750	4,8 x 75	PH2	65,79	4,40	250
981022120190	5,5 x 19	PH3	8,35	5,25	1000
981022120250	5,5 x 25	PH3	14,35	5,25	1000
981022120320	5,5 x 32	PH3	21,35	5,25	500
981022120380	5,5 x 38	PH3	27,35	5,25	500
981022120450	5,5 x 45	PH3	34,35	5,25	500
981022120500	5,5 x 50	PH3	39,35	5,25	250
981022140190	6,3 x 19	PH3	7,60	6	500
981022140250	6,3 x 25	PH3	13,60	6	500
981022140320	6,3 x 32	PH3	20,60	6	500
981022140380	6,3 x 38	PH3	26,60	6	250
981022140450	6,3 x 45	PH3	33,60	6	250
981022140500	6,3 x 50	PH3	38,60	6	250
981022140630	6,3 x 63	PH3	51,60	6	250

Mais medidas, matérias primas e acabamentos disponíveis em gama / More measurements, raw materials and finishes available in range / Plus de mesures, de matières premières et de finitions disponibles dans la gamme / Más medidas, materias primas y acabados disponibles en gama

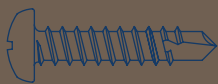

# PARAFUSOS AUTO-PERFURANTES E AUTO-ROSCANTES

Drill and Tapping Screws / Vis autoperceuse et Vis à Tôle / Tornillo autotaladrar y Autoroscante

## DIN 7504-P

### Parafuso Auto-Perfurante Cabeça Embeber Phillips

Self-drilling screw with countersunk head, Phillips recess / Vis autoperceuse, pointe foreuse, tête fraisée Phillips / Tornillo autotaladrante con cabeza avellanada y huella Phillips

DIN 7504-P

Zincado / Zinc Plated / Zingué / Zincado



CÓDIGO CODE / CODE / CÓDIGO	DIMENSÕES SIZE / DIMENSIONS MEDIDA		ESP. MAX A FIXAR MAX FIXTURE THICKNESS / ÉPAISSEUR MAX À FIXER/ ESP. MÁX A FIJAR	CAPACIDADE DE PERFURAÇÃO DRILL CAPACITY / CAPACITÉ DE PERÇADE / CAPACIDAD DE TALADRADO	EMBALAGEM QUANTITY / EMBALLAGE / EMBALAJE
982022060100	3,5 x 9,5	PH2	3,85	2,25	1000
982022060130	3,5 x 13	PH2	6,85	2,25	1000
982022060160	3,5 x 16	PH2	9,85	2,25	1000
982022060190	3,5 x 19	PH2	12,85	2,25	1000
982022060220	3,5 x 9,5	PH2	15,85	2,25	1000
982022060250	3,5 x 25	PH2	18,85	2,25	1000
982022070130	3,9 x 13	PH2	6,69	2,4	1000
982022070160	3,9 x 16	PH2	9,69	2,4	1000
982022070190	3,9 x 19	PH2	12,70	2,4	1000
982022070220	3,9 x 22	PH2	15,70	2,4	1000
982022070250	3,9 x 25	PH2	18,70	2,4	1000
982022070320	3,9 x 32	PH2	25,70	2,4	1000
982022080130	4,2 x 13	PH2	5,80	3	1000
982022080160	4,2 x 16	PH2	8,80	3	1000
982022080190	4,2 x 19	PH2	11,8	3	1000
982022080220	4,2 x 22	PH2	14,8	3	1000
982022080250	4,2 x 25	PH2	17,8	3	1000
982022080320	4,2 x 32	PH2	24,8	3	1000
982022080380	4,2 x 38	PH2	30,8	3	1000
982022100130	4,8 x 13	PH2	3,79	4,40	1000
982022100160	4,8 x 16	PH2	6,79	4,40	1000
982022100190	4,8 x 19	PH2	9,79	4,40	1000
982022100220	4,8 x 22	PH2	-	-	1000
982022100250	4,8 x 25	PH2	15,8	4,40	1000
982022100320	4,8 x 32	PH2	22,8	4,40	500
982022100380	4,8 x 38	PH2	28,8	4,40	500
982022100450	4,8 x 45	PH2	35,8	4,40	500

Mais medidas, matérias primas e acabamentos disponíveis em gama / More measurements, raw materials and finishes available in range / Plus de mesures, de matières premières et de finitions disponibles dans la gamme / Más medidas, materias primas y acabados disponibles en gama



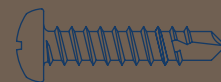



## Parafuso Auto-Perfurante Cabeça Sextavada

Bimetal, stainless-steel, self-drilling screw. Hexagon washer head / Vis autoperceuse, tête hexagonale avec collerette estampée. Inoxydable bimétal. / Tornillo autotaladrante inoxidable bimetal con cabeza hexagonal y arandela estampada

Parafuso / Vis / Screw / Tornillo

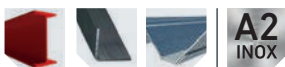
**BIMETAL**



CÓDIGO CODE / CODE / CÓDIGO	DIMENSÕES SIZE / DIMENSIONS MEDIDA		EMBALAGEM QUANTITY / EMBALLAGE / EMBALAJE
976362550250	5,5 x 25	8	500
976362550650	5,5 x 65	8	250
976362551000	5,5 x 100	8	100



Mais medidas, matérias primas e acabamentos disponíveis em gama / More measurements, raw materials and finishes available in range / Plus de mesures, de matières premières et de finitions disponibles dans la gamme / Más medidas, materias primas y acabados disponibles en gama

Tornillo con Arandela EPDM / Vis avec rondelle EPDM / Screw with EPDM Washer / Parafuso com anilha EPDM

**BIMETAL + EPDM**

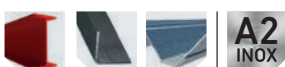

CÓDIGO CODE / CODE / CÓDIGO	DIMENSÕES SIZE / DIMENSIONS MEDIDA		EMBALAGEM QUANTITY / EMBALLAGE / EMBALAJE
976362550252	5,5 x 25 P16	8	500
976362550651	5,5 x 65 P16	8	250
976362550251	5,5 x 25 P25	8	500
976362550652	5,5 x 65 P25	8	250



Mais medidas, matérias primas e acabamentos disponíveis em gama / More measurements, raw materials and finishes available in range / Plus de mesures, de matières premières et de finitions disponibles dans la gamme / Más medidas, materias primas y acabados disponibles en gama

## Parafuso Auto-Perfurante Cabeça Sextavada

Self-drilling screw with panhead, Phillips recess / Vis autoperceuse, pointe foreuse, tête cylindrique bombée, Phillips / Tornillo autotaladrante de cabeza alomada y huella Phillips

# PCL 9762

Punta n.º 5 / Point foreuse n.º 5 / Drill point no. 5 / Ponta n.º 5

**PCL 9762**

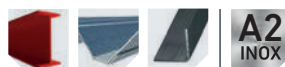

CÓDIGO CODE / CODE / CÓDIGO	DIMENSÕES SIZE / DIMENSIONS MEDIDA		EMBALAGEM QUANTITY / EMBALLAGE / EMBALAJE
976222550320	5,5 x 32	8	500
976222550601	5,5 x 60	8	250



Mais medidas, matérias primas e acabamentos disponíveis em gama / More measurements, raw materials and finishes available in range / Plus de mesures, de matières premières et de finitions disponibles dans la gamme / Más medidas, materias primas y acabados disponibles en gama

Con arandela EPDM / Avec rondelle EPDM / With EPDM washer / Com anilha EPDM

**PCL 9762**



CÓDIGO CODE / CODE / CÓDIGO	DIMENSÕES SIZE / DIMENSIONS MEDIDA		EMBALAGEM QUANTITY / EMBALLAGE / EMBALAJE
976222550322	5,5 x 32 P16	8	500
976222550602	5,5 x 60 P16	8	500



Mais medidas, matérias primas e acabamentos disponíveis em gama / More measurements, raw materials and finishes available in range / Plus de mesures, de matières premières et de finitions disponibles dans la gamme / Más medidas, materias primas y acabados disponibles en gama

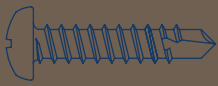

# PARAFUSOS AUTO-PERFURANTES E AUTO-ROSCANTES

Drill and Tapping Screws / Vis autopercuse et Vis à Tôle / Tornillo autotaladrar y Autoroscante

## DIN 7981

### Parafuso Auto-Roscante Cabeça Queijo Phillips

Cross recessed pan head tapping screw / Vis à tôle tête cylindrique bombée à empreinte cruciforme / Tornillo autoroscante de cabeza cil. abombada con hueco cruciforme

DIN 7981

Zincado / Zinc Plated / Zingué / Zincado

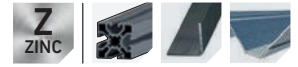

CÓDIGO CODE / CODE / CÓDIGO	DIMENSÕES SIZE / DIMENSIONS MEDIDA		EMBALAGEM QUANTITY / EMBALLAGE / EMBALAJE
798122020060	2 x 6	PH1	1000
798122020100	2 x 9,5	PH1	1000
798122020130	2 x 13	PH1	1000
798122020160	2 x 16	PH1	1000
798122020190	2 x 19	PH1	1000
798122040060	2,9 x 6	PH1	1000
798122040100	2,9 x 9,5	PH1	1000
798122040130	2,9 x 13	PH1	1000
798122040160	2,9 x 16	PH1	1000
798122040190	2,9 x 19	PH1	1000
798122040220	2,9 x 22	PH1	1000
798122040250	2,9 x 25	PH1	1000
798122060060	3,5 x 6	PH2	1000
798122060100	3,5 x 10	PH2	1000
798122060130	3,5 x 13	PH2	1000
798122060190	3,5 x 19	PH2	1000
798122060220	3,5 x 22	PH2	1000
798122060250	3,5 x 25	PH2	1000
798122060320	3,5 x 32	PH2	1000
798122060380	3,5 x 38	PH2	1000
798122070060	3,9 x 6	PH2	1000
798122070100	3,9 x 9,5	PH2	1000
798122070130	3,9 x 13	PH2	1000
798122070160	3,9 x 16	PH2	1000
798122070190	3,9 x 19	PH2	1000
798122070220	3,9 x 22	PH2	1000
798122070250	3,9 x 25	PH2	1000
798122070320	3,9 x 32	PH2	1000
798122070380	3,9 x 38	PH2	1000
798122070450	3,9 x 45	PH2	500
798122080100	4,2 x 9,5	PH2	1000
798122080130	4,2 x 13	PH2	1000
798122080160	4,2 x 16	PH2	1000
798122080190	4,2 x 19	PH2	1000
798122080220	4,2 x 22	PH2	1000

CÓDIGO CODE / CODE / CÓDIGO	DIMENSÕES SIZE / DIMENSIONS MEDIDA		EMBALAGEM QUANTITY / EMBALLAGE / EMBALAJE
798122080250	4,2 x 25	PH2	1000
798122080320	4,2 x 32	PH2	1000
798122080380	4,2 x 38	PH2	500
798122080450	4,2 x 45	PH2	500
798122080500	4,2 x 50	PH2	500
798122100100	4,8 x 9,5	PH2	1000
798122100130	4,8 x 13	PH2	1000
798122100160	4,8 x 16	PH2	1000
798122100190	4,8 x 19	PH2	1000
798122100220	4,8 x 22	PH2	1000
798122100250	4,8 x 25	PH2	1000
798122100320	4,8 x 32	PH2	500
798122100380	4,8 x 38	PH2	500
798122100450	4,8 x 45	PH2	500
798122100500	4,8 x 50	PH2	500
798122100630	4,8 x 63	PH2	500
798122100750	4,8 x 75	PH2	250
798122120130	5,5 x 13	PH3	200
798122120190	5,5 x 19	PH3	1000
798122120220	5,5 x 22	PH3	1000
798122120250	5,5 x 25	PH3	1000
798122120320	5,5 x 32	PH3	1000
798122120380	5,5 x 38	PH3	500
798122120450	5,5 x 45	PH3	500
798122120500	5,5 x 50	PH3	500
798122120630	5,5 x 63	PH3	250
798122140160	6,3 x 16	PH3	250
798122140190	6,3 x 19	PH3	500
798122140220	6,3 x 22	PH3	500
798122140250	6,3 x 25	PH3	500
798122140320	6,3 x 32	PH3	500
798122140380	6,3 x 38	PH3	500
798122140450	6,3 x 45	PH3	500
798122140500	6,3 x 50	PH3	250
798122140630	6,3 x 30	PH3	250

Mais medidas, matérias primas e acabamentos disponíveis em gama / More measurements, raw materials and finishes available in range / Plus de mesures, de matières premières et de finitions disponibles dans la gamme / Más medidas, materias primas y acabados disponibles en gama



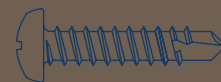



Negro / Noir / Black / Preto

DIN 7981



CÓDIGO CODE / CODE / CÓDIGO	DIMENSÕES SIZE / DIMENSIONS MEDIDA		EMBALAGEM QUANTITY / EMBALLAGE / EMBALAJE
798127060130	3,5 x 13	PH2	500
798127060160	3,5 x 16	PH2	500
798127060190	3,5 x 19	PH2	500
798127060250	3,5 x 25	PH2	250
798127080160	4,2 x 16	PH2	500
798127080190	4,2 x 19	PH2	500
798127080250	4,2 x 25	PH2	250
798127080320	4,2 x 32	PH2	250
798127080380	4,2 x 38	PH2	250

CÓDIGO CODE / CODE / CÓDIGO	DIMENSÕES SIZE / DIMENSIONS MEDIDA		EMBALAGEM QUANTITY / EMBALLAGE / EMBALAJE
798127100160	4,8 x 16	PH2	250
798127100190	4,8 x 19	PH2	250
798127100220	4,8 x 22	PH2	250
798127100250	4,8 x 25	PH2	250
798127100320	4,8 x 32	PH2	250
798127100380	4,8 x 38	PH2	250
798127100500	4,8 x 50	PH2	250
798127100630	4,8 x 60	PH2	250
798127100750	4,8 x 70	PH2	100





Mais medidas, matérias primas e acabamentos disponíveis em gama / More measurements, raw materials and finishes available in range / Plus de mesures, de matières premières et de finitions disponibles dans la gamme / Más medidas, materias primas y acabados disponibles en gama

Inoxidável A2 / Inoxydable A2 / Stainless Steel A2 / Aço Inox A2

DIN 7981



CÓDIGO CODE / CODE / CÓDIGO	DIMENSÕES SIZE / DIMENSIONS MEDIDA		EMBALAGEM QUANTITY / EMBALLAGE / EMBALAJE
798161040060	2,9 x 6	PH1	1000
798161040100	2,9 x 9,5	PH1	1000
798161040130	2,9 x 13	PH1	1000
798161040160	2,9 x 16	PH1	1000
798161040190	2,9 x 19	PH1	1000
798161040220	2,9 x 22	PH1	1000
798161040250	2,9 x 25	PH1	1000
798161060060	3,5 x 6	PH2	1000
798161060100	3,5 x 9,5	PH2	1000
798161060130	3,5 x 13	PH2	1000
798161060160	3,5 x 16	PH2	1000
798161060190	3,5 x 19	PH2	1000
798161060220	3,5 x 22	PH2	1000
798161060250	3,5 x 25	PH2	1000
798161060320	3,5 x 32	PH2	1000
798161060380	3,5 x 38	PH2	1000
798161070060	3,9 x 6	PH2	1000
798161070100	3,9 x 9,5	PH2	1000
798161070130	3,9 x 13	PH2	1000
798161070160	3,9 x 16	PH2	1000
798161070190	3,9 x 19	PH2	1000
798161070220	3,9 x 22	PH2	1000
798161070250	3,9 x 25	PH2	1000
798161070320	3,9 x 32	PH2	1000
798161070380	3,9 x 38	PH2	1000
798161080100	4,2 x 9,5	PH2	1000
798161080130	4,2 x 13	PH2	1000
798161080160	4,2 x 16	PH2	1000
798161080190	4,2 x 19	PH2	1000
798161080220	4,2 x 22	PH2	1000
798161080250	4,2 x 25	PH2	1000
798161080320	4,2 x 32	PH2	1000
798161080380	4,2 x 38	PH2	1000
798161080450	4,2 x 45	PH2	1000

CÓDIGO CODE / CODE / CÓDIGO	DIMENSÕES SIZE / DIMENSIONS MEDIDA		EMBALAGEM QUANTITY / EMBALLAGE / EMBALAJE
798161080500	4,2 x 50	PH2	1000
798161100100	4,8 x 9,5	PH2	1000
798161100130	4,8 x 13	PH2	1000
798161100160	4,8 x 16	PH2	1000
798161100190	4,8 x 19	PH2	1000
798161100220	4,8 x 22	PH2	1000
798161100250	4,8 x 25	PH2	1000
798161100320	4,8 x 32	PH2	1000
798161100380	4,8 x 38	PH2	250
798161100450	4,8 x 45	PH2	250
798161100500	4,8 x 50	PH2	1000
798161100630	4,8 x 63	PH2	1000
798161100750	4,8 x 75	PH2	1000
798161120130	5,5 x 13	PH3	1000
798161120160	5,5 x 16	PH3	1000
798161120190	5,5 x 19	PH3	1000
798161120220	5,5 x 22	PH3	1000
798161120250	5,5 x 25	PH3	1000
798161120320	5,5 x 32	PH3	250
798161120380	5,5 x 38	PH3	200
798161120450	5,5 x 45	PH3	100
798161120500	5,5 x 50	PH3	250
798161120630	5,5 x 63	PH3	1000
798161120750	5,5 x 75	PH3	200
798161140160	6,3 x 16	PH3	200
798161140190	6,3 x 19	PH3	200
798161140220	6,3 x 22	PH3	100
798161140250	6,3 x 25	PH3	100
798161140320	6,3 x 32	PH3	100
798161140380	6,3 x 38	PH3	100
798161140450	6,3 x 45	PH3	100
798161140500	6,3 x 50	PH3	100
798161140630	6,3 x 63	PH3	100
798161140750	6,3 x 75	PH3	100



Mais medidas, matérias primas e acabamentos disponíveis em gama / More measurements, raw materials and finishes available in range / Plus de mesures, de matières premières et de finitions disponibles dans la gamme / Más medidas, materias primas y acabados disponibles en gama

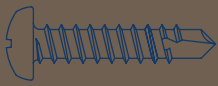

# PARAFUSOS AUTO-PERFURANTES E AUTO-ROSCANTES

Drill and Tapping Screws / Vis autoperceuse et Vis à Tôle / Tornillo autotaladrar y Autoroscante

## DIN 7982

### Parafuso Auto-Roscante Cabeça Embeber Phillips

Cross recessed countersunk head tapping screw / Vis à tête fraisée à empreinte cruciforme / Tornillo autoroscante de cabeça avellanada con hueco cruciforme

DIN 7982

Zincado / Zinc Plated / Zingué / Zincado



CÓDIGO CODE / CODE / CÓDIGO	DIMENSÕES SIZE / DIMENSIONS MEDIDA		EMBALAGEM QUANTITY / EMBALLAGE / EMBALAJE	CÓDIGO CODE / CODE / CÓDIGO	DIMENSÕES SIZE / DIMENSIONS MEDIDA		EMBALAGEM QUANTITY / EMBALLAGE / EMBALAJE
798222020160	2 x 16	PH1	1000	798222080450	4,2 x 45	PH2	1000
798222040060	2,9 x 6	PH1	1000	798222080500	4,2 x 50	PH2	1000
798222040100	2,9 x 9,5	PH1	1000	798222080630	4,2 x 63	PH2	250
798222040130	2,9 x 13	PH1	1000	798222100100	4,8 x 9,5	PH2	1000
798222040160	2,9 x 16	PH1	1000	798222100130	4,8 x 13	PH2	1000
798222040190	2,9 x 19	PH1	1000	798222100160	4,8 x 16	PH2	1000
798222040220	2,9 x 22	PH1	1000	798222100190	4,8 x 19	PH2	1000
798222040250	2,9 x 25	PH1	1000	798222100220	4,8 x 22	PH2	1000
798222040320	2,9 x 32	PH1	1000	798222100250	4,8 x 25	PH2	1000
798222060060	3,5 x 6	PH2	1000	798222100320	4,8 x 32	PH2	1000
798222060100	3,5 x 9,5	PH2	1000	798222100380	4,8 x 38	PH2	1000
798222060130	3,5 x 13	PH2	1000	798222100450	4,8 x 45	PH2	1000
798222060160	3,5 x 16	PH2	1000	798222100500	4,8 x 50	PH2	1000
798222060190	3,5 x 19	PH2	1000	798222100630	4,8 x 63	PH2	250
798222060220	3,5 x 22	PH2	1000	798222120130	5,5 x 13	PH3	1000
798222060250	3,5 x 25	PH2	1000	798222120100	5,5 x 9,5	PH3	1000
798222060320	3,5 x 32	PH2	1000	798222120160	5,5 x 16	PH3	1000
798222060380	3,5 x 38	PH2	1000	798222120190	5,5 x 19	PH3	1000
798222070060	3,9 x 6	PH2	1000	798222120220	5,5 x 22	PH3	1000
798222070100	3,9 x 9,5	PH2	1000	798222120250	5,5 x 25	PH3	1000
798222070130	3,9 x 13	PH2	1000	798222120320	5,5 x 32	PH3	1000
798222070160	3,9 x 16	PH2	1000	798222120380	5,5 x 38	PH3	1000
798222070190	3,9 x 19	PH2	1000	798222120450	5,5 x 45	PH3	1000
798222070220	3,9 x 22	PH2	1000	798222120500	5,5 x 50	PH3	250
798222070250	3,9 x 25	PH2	1000	798222120570	5,5 x 57	PH3	250
798222070320	3,9 x 32	PH2	1000	798222120630	5,5 x 63	PH3	250
798222070380	3,9 x 38	PH2	1000	798222140160	6,3 x 16	PH3	1000
798222070450	3,9 x 45	PH2	500	798222140190	6,3 x 19	PH3	1000
798222080100	4,2 x 9,5	PH2	1000	798222140220	6,3 x 22	PH3	1000
798222080130	4,2 x 13	PH2	1000	798222140250	6,3 x 25	PH3	1000
798222080160	4,2 x 16	PH2	1000	798222140320	6,3 x 32	PH3	1000
798222080190	4,2 x 19	PH2	1000	798222140380	6,3 x 38	PH3	250
798222080220	4,2 x 22	PH2	1000	798222140450	6,3 x 45	PH3	250
798222080250	4,2 x 25	PH2	1000	798222140500	6,3 x 50	PH3	250
798222080320	4,2 x 32	PH2	1000	798222140630	6,3 x 63	PH3	250
798222080380	4,2 x 38	PH2	1000				

Mais medidas, matérias primas e acabamentos disponíveis em gama / More measurements, raw materials and finishes available in range / Plus de mesures, de matières premières et de finitions disponibles dans la gamme / Más medidas, materias primas y acabados disponibles en gama

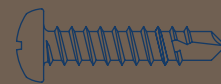

## Parafuso Auto-Roscante Cabeça Lentilha Phillips

Cross recessed raised countersunk head tapping screw / Vis à tête fraisée bombée à empreinte cruciforme  
/ Tornillo autoroscante de cabeza avellanada con hueco cruciforme

# DIN 7983

Zincado / Zingué / Zinc Plated / **Zincado**

**DIN 7983**

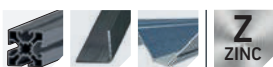

CÓDIGO CODE / CODE / CÓDIGO	DIMENSÕES SIZE / DIMENSIONS MEDIDA		EMBALAGEM QUANTITY / EMBALLAGE / EMBALAJE
798322040060	2,9 x 6	PH1	1000
798322040100	2,9 x 9,5	PH1	1000
798322040160	2,9 x 16	PH1	1000
798322040190	2,9 x 19	PH1	1000
798322040220	2,9 x 22	PH1	1000
798322040250	2,9 x 25	PH1	1000
798322060060	3,5 x 6	PH2	1000
798322060100	3,5 x 9,5	PH2	1000
798322060160	3,5 x 16	PH2	1000
798322060190	3,5 x 19	PH2	1000
798322060220	3,5 x 22	PH2	1000
798322060250	3,5 x 25	PH2	1000
798322060320	3,5 x 32	PH2	1000
798322060380	3,5 x 38	PH2	1000
798322060500	3,5 x 50	PH2	500
798322070100	3,9 x 9,5	PH2	1000
798322070130	3,9 x 13	PH2	1000
798322070160	3,9 x 16	PH2	1000
798322070190	3,9 x 19	PH2	1000
798322070220	3,9 x 22	PH2	1000
798322070250	3,9 x 25	PH2	1000
798322070320	3,9 x 32	PH2	1000
798322070380	3,9 x 38	PH2	1000
798322070450	3,9 x 45	PH2	500
798322080100	4,2 x 9,5	PH2	1000
798322080130	4,2 x 13	PH2	1000
798322080160	4,2 x 16	PH2	1000
798322080190	4,2 x 19	PH2	1000
798322080220	4,2 x 22	PH2	1000
798322080250	4,2 x 25	PH2	1000
798322080320	4,2 x 32	PH2	1000
798322080380	4,2 x 38	PH2	1000
798322080450	4,2 x 45	PH2	500
798322080500	4,2 x 50	PH2	500
798322100100	4,8 x 9,5	PH2	1000
798322100130	4,8 x 13	PH2	1000
798322100160	4,8 x 16	PH2	1000
798322100190	4,8 x 19	PH2	1000
798322100220	4,8 x 22	PH2	1000
798322100250	4,8 x 25	PH2	1000
798322100320	4,8 x 32	PH2	500
798322100380	4,8 x 38	PH2	500
798322100450	4,8 x 45	PH2	500

Mais medidas, matérias primas e acabamentos disponíveis em gama / More measurements, raw materials and finishes available in range / Plus de mesures, de matières premières et de finitions disponibles dans la gamme / Más medidas, materias primas y acabados disponibles en gama

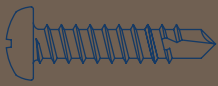

# PARAFUSOS AUTO-PERFURANTES E AUTO-ROSCANTES

Drill and Tapping Screws / Vis autoperceuse et Vis à Tôle / Tornillo autotaldrar y Autoroscante

## DIN 6928

### Parafuso Auto-Roscante Cabeça Sextavada com Falsa Anilha

Hexagon washer head tapping screws / Vis à tôle tête hexagonale à embase cylindrique avec rondelle / Tornillo autoroscante con cabeza hexagonal con collarin

DIN 6928

Zincado / Zinc Plated / Zingué / Zincado

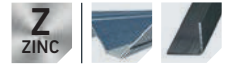

CÓDIGO CODE / CODE / CÓDIGO	DIMENSÕES SIZE / DIMENSIONS MEDIDA		EMBALAGEM QUANTITY / EMBALLAGE / EMBALAJE
692822630160	6,3 x 16	10	500
692822630200	6,3 x 20	10	500
692822630250	6,3 x 25	10	500
692822630320	6,3 x 32	10	500
692822630350	6,3 x 35	10	500
692822630400	6,3 x 40	10	250
692822630500	6,3 x 50	10	250
692822630600	6,3 x 60	10	250
692822630750	6,3 x 75	10	250
692822630900	6,3 x 90	10	250
692822631000	6,3 x 100	10	250
692822631100	6,3 x 110	10	250
692822631200	6,3 x 120	10	250
692822631300	6,3 x 130	10	250
692822631400	6,3 x 140	10	250
692822631500	6,3 x 150	10	250

Mais medidas, matérias primas e acabamentos disponíveis em gama / More measurements, raw materials and finishes available in range / Plus de mesures, de matières premières et de finitions disponibles dans la gamme / Más medidas, materias primas y acabados disponibles en gama



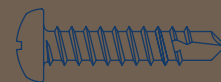

## Parafuso Auto-Roscante com Anilha EPDM

Hexagon head self tapping screw, zinc plated / Vis a tête hexagonale avec rondelle en néoprène / Tornillo autoroscante con cabeza hexagonal y arandella, zincado

# PCL 8975

Zincado / Zingué / Zinc Plated / Zincado

PCL8975 + EPDM



CÓDIGO CODE / CODE / CÓDIGO	DIMENSÕES SIZE / DIMENSIONS MEDIDA		EMBALAGEM QUANTITY / EMBALLAGE / EMBALAJE
897522480190	4,8 x 19 P18	10	1000
897522630200	6,3 x 20 P18	10	250
897522630250	6,3 x 25 P18	10	250
897522630350	6,3 x 35 P18	10	250
897522630400	6,3 x 40 P18	10	250
897522630500	6,3 x 50 P18	10	250
897522630600	6,3 x 60 P18	10	200
897522630750	6,3 x 75 P18	10	200
897522630760	6,3 x 76 P18	10	200
897522630900	6,3 x 90 P18	10	100
897522631000	6,3 x 100 P18	10	100
897522631100	6,3 x 110 P18	10	100
897522631200	6,3 x 120 P18	10	100
897522631400	6,3 x 140 P18	10	50
897522631500	6,3 x 150 P18	10	50
897522550200	5,5 x 20 P25	10	250
897522630201	6,3 x 20 P25	10	250
897522630251	6,3 x 25 P25	10	250
897522630401	6,3 x 40 P25	10	250
897522630501	6,3 x 50 P25	10	200
897522630601	6,3 x 60 P25	10	200
897522630901	6,3 x 90 P25	10	100
897522631001	6,3 x 100 P25	10	100
897522631101	6,3 x 110 P25	10	100
897522631201	6,3 x 120 P25	10	100



Mais medidas, matérias primas e acabamentos disponíveis em gama / More measurements, raw materials and finishes available in range / Plus de mesures, de matières premières et de finitions disponibles dans la gamme / Más medidas, materias primas y acabados disponibles en gama

## Parafuso para Fibrocimento com Anilha

Self-drilling screw for fibre cement, assembled with umbrella water / Vis autoperceuse pointe foreuse pour fibrociment / Tornillo autotaladrante para fibrocimento, montado con arandela paraguas

# PCL 8974

Zincado / Zingué / Zinc Plated / Zincado

PCL 8974



CÓDIGO CODE / CODE / CÓDIGO	DIMENSÕES SIZE / DIMENSIONS MEDIDA		ESP. MÁX A FIXAR MAX FIXTURE THICKNESS / ÉPAISSEUR MÁX À FIXER/ ESP. MÁX A FIJAR	CAPACIDADE DE PERFURAÇÃO DRILL CAPACITY / CAPACITÉ DE PERÇADE / CAPACIDAD DE TALADRADO	EMBALAGEM QUANTITY / EMBALLAGE / EMBALAJE
897422631150	6,3 x 115	8	85	6	100
897422631250	6,3 x 125	8	95	6	100
897422631300	6,3 x 130	8	95	12	100
897422631500	6,3 x 150	8	115	12	50
897422631600	6,3 x 160	8	125	12	50



Mais medidas, matérias primas e acabamentos disponíveis em gama / More measurements, raw materials and finishes available in range / Plus de mesures, de matières premières et de finitions disponibles dans la gamme / Más medidas, materias primas y acabados disponibles en gama

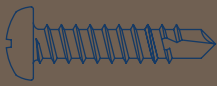

# PARAFUSOS AUTO-PERFURANTES E AUTO-ROSCANTES

Drill and Tapping Screws / Vis autoperceuse et Vis à Tôle / Tornillo autotaladrar y Autoroscante

## Anilha Neoprene

Vulcanized EPDM-steel washer / Rondelle vulcanisée d'étanchéité, acier-EPDM / Arandela vulcanizada de acero-EPDM

EPDM

Pregalvanizada / Pregalvanized / Pregalvanisée / Pregalvanizada



CÓDIGO CODE / CODE / CÓDIGO	DIMENSÕES SIZE / DIMENSIONS MEDIDA	INTERIOR ANILHA WASHER INNER / INTÉRIEUR RONDELLE/ INTERIOR ARANDELA	EMBALAGEM QUANTITY / EMBALLAGE / EMBALAJE
000102480000	P14	4,8	1000
000102550000	P16	5,5	1000
000102550001	P25	5,5	500
000102630000	P18	6,3	1000
000102630001	P25	6,3	500

Mais medidas, matérias primas e acabamentos disponíveis em gama / More measurements, raw materials and finishes available in range / Plus de mesures, de matières premières et de finitions disponibles dans la gamme / Más medidas, materias primas y acabados disponibles en gama

EPDM

Aço Inox A2 / Stainless Steel A2 / Inoxydable A2 / Inoxidable A2



CÓDIGO CODE / CODE / CÓDIGO	DIMENSÕES SIZE / DIMENSIONS MEDIDA	INTERIOR ANILHA WASHER INNER / INTÉRIEUR RONDELLE/ INTERIOR ARANDELA	EMBALAGEM QUANTITY / EMBALLAGE / EMBALAJE
000261550000	P14	4,8	1000
000261550001	P16	5,5	1000
000261550001	P25	5,5	500
000261630000	P18	6,3	1000
000261630001	P25	6,3	500

Mais medidas, matérias primas e acabamentos disponíveis em gama / More measurements, raw materials and finishes available in range / Plus de mesures, de matières premières et de finitions disponibles dans la gamme / Más medidas, materias primas y acabados disponibles en gama

EPDM

Alumínio / Aluminum / Aluminium / Aluminio



CÓDIGO CODE / CODE / CÓDIGO	DIMENSÕES SIZE / DIMENSIONS MEDIDA	INTERIOR ANILHA WASHER INNER / INTÉRIEUR RONDELLE/ INTERIOR ARANDELA	EMBALAGEM QUANTITY / EMBALLAGE / EMBALAJE
000281630000	P18	6,3	1000
000281630001	P25	6,3	500

## Parafuso Auto-Roscante Cabeça de Embeber Phillips

Extra low head self-tapping screw, Phillips recess / Vis à tôle, avec tête extraplate, empreinte Phillips / Tornillo rosca chapa con cabeza extraplana y huella Phillips

Zincado / Zinc Plated / Zingú / Zincado



CÓDIGO CODE / CODE / CÓDIGO	DIMENSÕES SIZE / DIMENSIONS MEDIDA		ESP. MÁX A FIXAR MAX FIXTURE THICKNESS / ÉPAISSEUR MAX À FIXER/ ESP. MÁX A FIJAR	EMBALAGEM QUANTITY / EMBALLAGE / EMBALAJE
000722012510	4,2 x 14	PH2	8	1000

Mais medidas, matérias primas e acabamentos disponíveis em gama / More measurements, raw materials and finishes available in range / Plus de mesures, de matières premières et de finitions disponibles dans la gamme / Más medidas, materias primas y acabados disponibles en gama

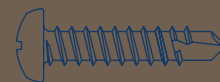

Inoxidável A2 / Inoxydable A2 / Stainless Steel A2 / Aço Inox A2

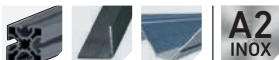

CÓDIGO CODE / CODE / CÓDIGO	DIMENSÕES SIZE / DIMENSIONS MEDIDA		ESP. MAX A FIXAR MAX FIXTURE THICKNESS / ÉPAISSEUR MAX À FIXER/ ESP. MÁX A FIJAR	EMBALAGEM QUANTITY / EMBALLAGE / EMBALAJE
000761012510	4,2 x 14	PH2	8	1000





Mais medidas, matérias primas e acabamentos disponíveis em gama / More measurements, raw materials and finishes available in range / Plus de mesures, de matières premières et de finitions disponibles dans la gamme / Más medidas, materias primas y acabados disponibles en gama

## Parafuso Auto-Perfurante Cabeça de Menisco Phillips com Anilha

Self-drilling extra low panhead screw, Phillip recess / Vis autoperceuse, pointe foreuse, tête bombée Phillips, avec rondelle estampée / Tornillo autotaladrante de cabeza alomada baja, huella Phillips y arandela estampada

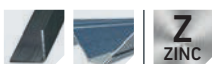
Zincado / Zinguê / Zinc Plated / Zincado



CÓDIGO CODE / CODE / CÓDIGO	DIMENSÕES SIZE / DIMENSIONS MEDIDA		ESP. MAX A FIXAR MAX FIXTURE THICKNESS / ÉPAISSEUR MAX À FIXER/ ESP. MÁX A FIJAR	EMBALAGEM QUANTITY / EMBALLAGE / EMBALAJE
000722794901	4,2 x 13	PH2	8	1000
000722012510	4,2 x 25	PH2	8	1000



Mais medidas, matérias primas e acabamentos disponíveis em gama / More measurements, raw materials and finishes available in range / Plus de mesures, de matières premières et de finitions disponibles dans la gamme / Más medidas, materias primas y acabados disponibles en gama

Negro / Noir / Black / Preto



CÓDIGO CODE / CODE / CÓDIGO	DIMENSÕES SIZE / DIMENSIONS MEDIDA		ESP. MAX A FIXAR MAX FIXTURE THICKNESS / ÉPAISSEUR MAX À FIXER/ ESP. MÁX A FIJAR	CAPACIDADE DE PERFURAÇÃO DRILL CAPACITY / CAPACITÉ DE PERÇADE / CAPACIDAD DE TALADRADO	EMBALAGEM QUANTITY / EMBALLAGE / EMBALAJE
000727794901	4,2 x 13	PH2	4,3	0,75 - 2,5	1000
000727794902	4,2 x 25	PH2	16,3	0,75 - 2,5	1000



Mais medidas, matérias primas e acabamentos disponíveis em gama / More measurements, raw materials and finishes available in range / Plus de mesures, de matières premières et de finitions disponibles dans la gamme / Más medidas, materias primas y acabados disponibles en gama

# PARAFUSOS AUTO-PERFORANTES E AUTO-ROSCANTES

Drill and Tapping Screws / Vis autoperceuse et Vis à Tôle / Tornillo autotaladrar y Autoroscante

## GAMA DISPONÍVEL / Available range / Gamme disponible / Gama disponibile

<b>PARAFUSOS AUTO-ROSCANTES</b> / SELF TAPPING SCREWS / VIS À TÔLE / TORNILLOS AUTORROSCANTES	 <p>DIN 7506</p>	<b>PARAFUSOS ROSCA PVC</b> / PVC SCREWS / VIS POUR MENUISERIE PVC / TORNILLOS ROSCA PVC	 <p>PCL 226 C91</p>	 <p>PCL 7507</p>	 <p>PCL 8971</p>
 <p>DIN 7971 ISO 1481</p>	 <p>DIN 7508</p>	 <p>PCL 225</p>	 <p>PCL 225 ATP métrico</p>	 <p>PCL 7508</p>	 <p>PCL 8970</p>
 <p>DIN 7972 ISO 1482</p>	 <p>DIN 7976 ISO 1479</p>	 <p>PCL 226</p>	<b>PARAFUSOS AUTO-PERFORANTES</b> / SELF DRILLING SCREWS / VIS AUTOPERCEUSE / TORNILLOS AUTOTALADRANTES	 <p>PCL 7509</p>	
 <p>DIN 7973 ISO 1483</p>	 <p>PCL 6930</p>	 <p>PCL 226 C74</p>	 <p>PCL 9810 ISO 7584 M (M)</p>	 <p>PCL 9800</p>	<p><b>CATÁLOGO TÉCNICO</b>          FIXING CATALOGUE          / CATALOGUE TECHNIQUE          / CATÁLOGO TÉCNICO</p>
 <p>PCL 6929</p>	 <p>PCL 6931</p>	 <p>PCL 226 C86</p>	 <p>PCL 9820 ISO 7584 O (P)</p>	 <p>PCL 9762</p>	







# PARAFUSOS DE MADEIRA

WOOD SCREWS  
VIS POUR BOIS  
TORNILLOS PARA MADERA



# PARAFUSOS PARA MADEIRA

Wood Screws / Vis pour Bois / Tornillos para Madera

## PCL 211

### Parafuso alto rendimento aglomerado cabeça embeber

High-performance chipboard screw / Vis à bois à haut rendement / Tirafondo de alto rendimiento

PCL 211

Zincado / Zinc Plated / Zingué / Zincado



CÓDIGO CODE / CODE / CÓDIGO	DIMENSÕES SIZE / DIMENSIONS MEDIDA		EMBALAGEM QUANTITY / EMBALLAGE / EMBALAJE
021122040250	4 x 25	T20	200
021122040300	4 x 30	T20	200
021122040350	4 x 35	T20	200
021122040450	4 x 45	T20	200
021122040500	4 x 50	T20	200
021122040550	4 x 55	T20	200
021122050250	5 x 25	T20	200
021122050300	5 x 30	T25	200
021122050350	5 x 35	T25	200
021122050400	5 x 40	T25	200
021122050450	5 x 45	T25	200
021122050500	5 x 50	T25	200
021122050600	5 x 60	T25	100
021122050700	5 x 70	T25	100
021122050800	5 x 80	T25	100
021122050900	5 x 90	T25	100
021122051000	5 x 100	T25	200
021122060400	6 x 40	T25	200
021122060450	6 x 45	T25	100
021122060500	6 x 50	T25	100
021122060600	6 x 60	T25	100
021122060700	6 x 70	T25	100
021122060800	6 x 80	T25	100
021122060900	6 x 90	T25	100
021122061000	6 x 100	T25	100

CÓDIGO CODE / CODE / CÓDIGO	DIMENSÕES SIZE / DIMENSIONS MEDIDA		EMBALAGEM QUANTITY / EMBALLAGE / EMBALAJE
021122061100	6 x 110	T25	100
021122061200	6 x 120	T25	100
021122061300	6 x 130	T25	100
021122061400	6 x 140	T25	100
021122061500	6 x 150	T25	100
021122061600	6 x 160	T25	100
021122061800	6 x 180	T25	100
021122062000	6 x 200	T25	100
021122062200	6 x 220	T25	100
021122062400	6 x 240	T25	50
021122062600	6 x 260	T25	50
021122062800	6 x 280	T25	50
021122063000	6 x 300	T25	50
021122080800	8 x 80	T40	50
021122081000	8 x 100	T40	50
021122081200	8 x 120	T40	50
021122081400	8 x 140	T40	50
021122081600	8 x 160	T40	50
021122081800	8 x 180	T40	50
021122082000	8 x 200	T40	200
021122082200	8 x 220	T40	200
021122082400	8 x 240	T40	100
021122082600	8 x 260	T40	100
021122082800	8 x 280	T40	100
021122083000	8 x 300	T40	100

Mais medidas, matérias primas e acabamentos disponíveis em gama / More measurements, raw materials and finishes available in range / Plus de mesures, de matières premières et de finitions disponibles dans la gamme / Más medidas, materias primas y acabados disponibles en gama

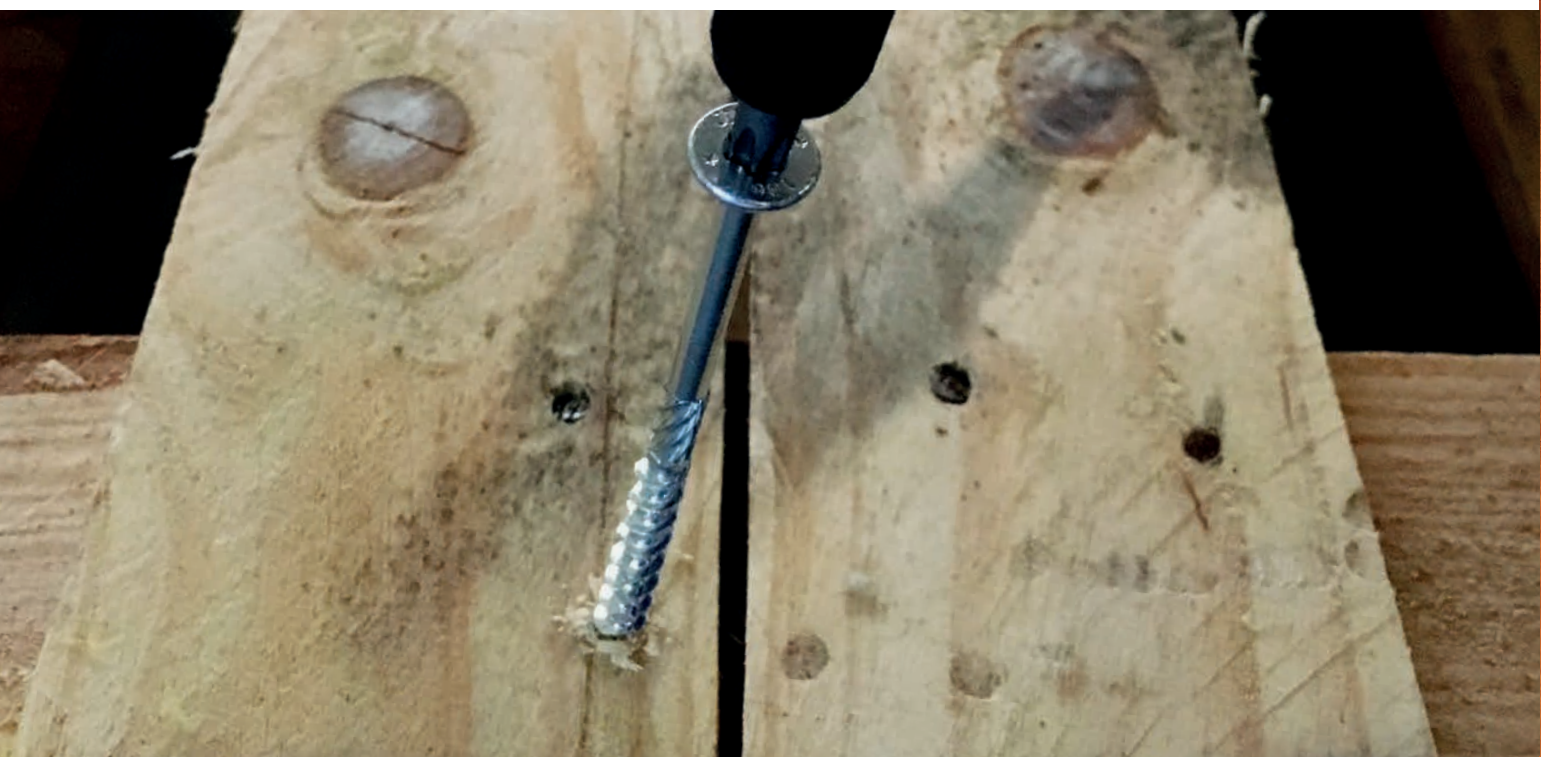

# express PLUS

**PCL211**

**Parafuso alto rendimento aglomerado  
cabeça embeber**

High-performance chipboard screw / Vis à bois à haut rendement  
/ Tirafundo de alto rendimento



**Z**  
ZINC

O Express Plus é um parafuso de elevadas prestações devido ao seu desenho único e inovador. As suas características técnicas distinguem-nos como a melhor opção para trabalhos que requerem alto rendimento.

Express Plus is a high performance screw due to its unique and innovative design. Its technical characteristics stand out as the best option for works requiring high performances.

La vis Express PLUS est une vis de haute performance en raison de son design unique et innovant. Ses caractéristiques techniques distinguent comme la meilleure option pour des travaux qui nécessitent des performances élevées.

El Express Plus es un tornillo de alto rendimiento debido a su diseño único e innovador. Sus características lo distinguen como la mejor opción para trabajos que requieren alto rendimiento.

**1) ESCAREADORES NA PARTE INFERIOR DA CABEÇA (8 A 14 - CONSOANTE A MEDIDA).**

1) REAMERS AT THE BOTTOM OF THE HEAD (8 TO 14 - DEPENDING ON SIZE).

1) NERVURES AUTOFRAISANTES SOUS LA TÊTE (DE 8 À 14 - EN FONCTION DE LA MESURE DE LA VIS).

1) ESCARIADORES EN LA PARTE INFERIOR DE LA CABEZA (8 A 14 - EN FUNCIÓN DE LA MEDIDA).

**2) LUBRIFICAÇÃO ANTI-FRICÇÃO.**

2) ANTI-FRICTION LUBRICATION.

2) LUBRIFICATION ANTI FRICTION.

2) LUBIFICACIÓN ANTIFRICCIÓN

**3) ROSCA INOVADORA. MAIOR PODER DE PENETRAÇÃO NOS VÁRIOS MATERIAIS.**

3) INNOVATIVE THREAD. LARGER PENETRATION POWER IN VARIOUS MATERIALS.

3) PROFIL DU FILET INNOVANT. MEILLEUR PÉNÉTRATION DANS LES DIVERS MATÉRIAUX.

3) ROSCA INNOVADORA. MÁS PODER DE PENETRACIÓN EN MATERIALES DIVERSOS.

**4) ROSCA GWSR FRIZADA PARA FACILITAR O "ATAQUE" A MADEIRAS DURAS.**

4) GWSR CURLY THREAD FOR FAST SCREWING WITH MINIMAL EFFORT.

4) FILETAGE GWSR FRISÉE POUR UNE VISSAGE RAPIDE AVEC UN MINIMUM D'EFFORT.

4) ROSCA GWSR SERRADA PARA FACILITAR LA PENETRACIÓN EN MADERAS DURAS.

**5) PONTA CENTRADORA DE 25° PARA FACILITAR O POSICIONAMENTO DO PARAFUSO E PENETRAÇÃO NO SUBSTRATO.**

5) POINT 25° TO HELP POSITIONING OF THE SCREW AND A GRADUAL PENETRATION.

5) FILETAGE GWSR FRISÉE POUR UNE VISSAGE RAPIDE AVEC UN MINIMUM D'EFFORT/POINTE DE 25° POUR FACILITER LE POSITIONNEMENT DE LA VIS ET UNE PÉNÉTRATION PROGRESSIVE.

5) PUNTA CENTRADORA DE 25° PARA FACILITAR LA COLOCACIÓN DEL TORNILLO Y LA PENETRACIÓN EN EL MATERIAL.

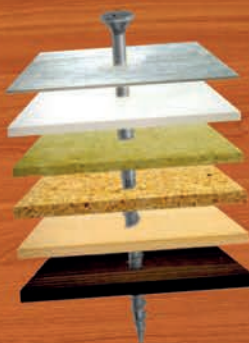

**CHAPAS FINAS / THIN SHEETS / TÔLES FINES / CHAPAS FINAS**

**PVC / PVC / PVC / PVC**

**MDF / MDF / MDF / DM**

**AGLOMERADO / CHIPBOARD / PANNEAUX AGGLOMÉRÉS / AGLOMERADO**

**MADEIRA / WOOD / BOIS / MADERA**



# PARAFUSOS PARA MADEIRA

Wood Screws / Vis pour Bois / Tornillos para Madera

## PCL 202

### Parafuso Aglomerado Cabeça Embeber. Pozidrive

Chipboard screw with countersunk 90° head, 40° thread, special coating. Pozidriv / Vis à bois. Tête fraisée 90°. Lubrifiée. Pozidriv / Tirafo de cabeça avellanada 90°, filete 40°, lubrificado. Pozidriv

PCL 202



Passivado Amarelo / Yellow Zinc Plated / Bichomaté / Bicromatado

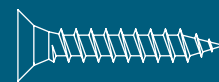

CÓDIGO CODE / CODE / CÓDIGO	DIMENSÕES SIZE / DIMENSIONS MEDIDA		EMBALAGEM QUANTITY / EMBALLAGE / EMBALAJE	CÓDIGO CODE / CODE / CÓDIGO	DIMENSÕES SIZE / DIMENSIONS MEDIDA		EMBALAGEM QUANTITY / EMBALLAGE / EMBALAJE
020223240120	2,4 x 12	PZ1	1000	020223450160	4,5 x 16	PZ2	1000
020223260120	2,6 x 12	PZ1	1000	020223450200	4,5 x 20	PZ2	1000
020223260160	2,6 x 16	PZ1	1000	020223450250	4,5 x 25	PZ2	1000
020223260180	2,6 x 18	PZ1	1000	020223450300	4,5 x 30	PZ2	1000
020223260200	2,6 x 20	PZ1	1000	020223450350	4,5 x 35	PZ2	500
020223260250	2,6 x 25	PZ1	1000	020223450400	4,5 x 40	PZ2	500
020223260300	2,6 x 30	PZ1	1000	020223450450	4,5 x 45	PZ2	500
020223030100	3 x 10	PZ1	1000	020223450500	4,5 x 50	PZ2	500
020223030120	3 x 12	PZ1	1000	020223450550	4,5 x 55	PZ2	500
020223030160	3 x 16	PZ1	1000	020223450600	4,5 x 60	PZ2	250
020223030180	3 x 18	PZ1	1000	020223450650	4,5 x 65	PZ2	200
020223030200	3 x 20	PZ1	1000	020223450700	4,5 x 70	PZ2	200
020223030250	3 x 25	PZ1	1000	020223450800	4,5 x 80	PZ2	200
020223030300	3 x 30	PZ1	1000	020223050160	5 x 16	PZ2	1000
020223030350	3 x 35	PZ1	1000	020223050200	5 x 20	PZ2	1000
020223030400	3 x 40	PZ1	1000	020223050250	5 x 25	PZ2	1000
020223030450	3 x 45	PZ1	500	020223050300	5 x 30	PZ2	1000
020223030500	3 x 50	PZ1	500	020223050350	5 x 35	PZ2	500
020223350120	3,5 x 12	PZ2	1000	020223050400	5 x 40	PZ2	500
020223350140	3,5 x 14	PZ2	1000	020223050450	5 x 45	PZ2	500
020223350160	3,5 x 16	PZ2	1000	020223050500	5 x 50	PZ2	500
020223350180	3,5 x 18	PZ2	1000	020223050600	5 x 60	PZ2	250
020223350200	3,5 x 20	PZ2	1000	020223050700	5 x 70	PZ2	250
020223350250	3,5 x 25	PZ2	1000	020223050800	5 x 80	PZ2	200
020223350300	3,5 x 30	PZ2	1000	020223050900	5 x 90	PZ2	200
020223350350	3,5 x 35	PZ2	1000	020223051000	5 x 100	PZ2	200
020223350400	3,5 x 40	PZ2	1000	020223060300	6 x 30	PZ3	500
020223350450	3,5 x 45	PZ2	500	020223060400	6 x 40	PZ3	500
020223350500	3,5 x 50	PZ2	500	020223060450	6 x 45	PZ3	500
020223040100	4 x 10	PZ2	1000	020223060500	6 x 50	PZ3	250
020223040120	4 x 12	PZ2	1000	020223060600	6 x 60	PZ3	250
020223040160	4 x 16	PZ2	1000	020223060700	6 x 70	PZ3	200
020223040180	4 x 18	PZ2	1000	020223060800	6 x 80	PZ3	100
020223040200	4 x 20	PZ2	1000	020223060900	6 x 90	PZ2	100
020223040250	4 x 25	PZ2	1000	020223061000	6 x 100	PZ3	100
020223040300	4 x 30	PZ2	1000	020223061100	6 x 110	PZ3	100
020223040350	4 x 35	PZ2	1000	020223061200	6 x 120	PZ3	100
020223040400	4 x 40	PZ2	1000	020223061300	6 x 130	PZ3	100
020223040450	4 x 45	PZ2	500	020223061400	6 x 140	PZ3	100
020223040500	4 x 50	PZ2	500	020223061500	6 x 150	PZ3	100
020223040550	4 x 55	PZ2	500	020223061600	6 x 160	PZ3	100
020223040600	4 x 60	PZ2	500	020223061800	6 x 180	PZ3	100
020223450120	4,5 x 12	PZ2	1000	020223062000	6 x 200	PZ3	100

Mais medidas, matérias primas e acabamentos disponíveis em gama / More measurements, raw materials and finishes available in range / Plus de mesures, de matières premières et de finitions disponibles dans la gamme / Más medidas, materias primas y acabados disponibles en gama



CÓDIGO CODE / CODE / CÓDIGO	DIMENSÕES SIZE / DIMENSIONS MEDIDA		EMBALAGEM QUANTITY / EMBALLAGE / EMBALAJE	CÓDIGO CODE / CODE / CÓDIGO	DIMENSÕES SIZE / DIMENSIONS MEDIDA		EMBALAGEM QUANTITY / EMBALLAGE / EMBALAJE
020222260120	2,6 x 12	PZ1	1000	020222450160	4,5 x 16	PZ2	1000
020222260160	2,6 x 16	PZ1	1000	020222450180	4,5 x 18	PZ2	1000
020222260180	2,6 x 18	PZ1	1000	020222450200	4,5 x 20	PZ2	1000
020222260200	2,6 x 20	PZ1	1000	020222450250	4,5 x 25	PZ2	1000
020222260250	2,6 x 25	PZ1	1000	020222450300	4,5 x 30	PZ2	1000
020222030100	3 x 10	PZ1	1000	020222450350	4,5 x 35	PZ2	500
020222030120	3 x 12	PZ1	1000	020222450400	4,5 x 40	PZ2	500
020222030160	3 x 16	PZ1	1000	020222450450	4,5 x 45	PZ2	500
020222030180	3 x 18	PZ1	1000	020222450500	4,5 x 50	PZ2	500
020222030200	3 x 20	PZ1	1000	020222450550	4,5 x 55	PZ2	500
020222030250	3 x 25	PZ1	1000	020222450600	4,5 x 60	PZ2	250
020222030300	3 x 30	PZ1	1000	020222450700	4,5 x 70	PZ2	200
020222030350	3 x 35	PZ1	1000	020222450800	4,5 x 80	PZ2	200
020222030400	3 x 40	PZ1	1000	020222050160	5 x 16	PZ2	1000
020222030450	3 x 45	PZ1	500	020222050200	5 x 20	PZ2	1000
020222030500	3 x 50	PZ1	500	020222050250	5 x 25	PZ2	1000
020222350100	3,5 x 10	PZ2	1000	020222050300	5 x 30	PZ2	1000
020222350120	3,5 x 12	PZ2	1000	020222050350	5 x 35	PZ2	500
020222350160	3,5 x 16	PZ2	1000	020222050400	5 x 40	PZ2	500
020222350180	3,5 x 18	PZ2	1000	020222050450	5 x 45	PZ2	500
020222350200	3,5 x 20	PZ2	1000	020222050500	5 x 50	PZ2	500
020222350250	3,5 x 25	PZ2	1000	020222050600	5 x 60	PZ2	250
020222350300	3,5 x 30	PZ2	1000	020222050700	5 x 70	PZ2	250
020222350350	3,5 x 35	PZ2	1000	020222050800	5 x 80	PZ2	200
020222350400	3,5 x 40	PZ2	1000	020222050900	5 x 90	PZ2	200
020222350450	3,5 x 45	PZ2	500	020222051000	5 x 100	PZ2	200
020222350500	3,5 x 50	PZ2	500	020222060300	6 x 30	PZ3	500
020222040100	4 x 10	PZ2	1000	020222060350	6 x 35	PZ3	500
020222040120	4 x 12	PZ2	1000	020222060400	6 x 40	PZ3	500
020222040160	4 x 16	PZ2	1000	020222060450	6 x 45	PZ3	500
020222040180	4 x 18	PZ2	1000	020222060500	6 x 50	PZ3	250
020222040200	4 x 20	PZ2	1000	020222060600	6 x 60	PZ3	250
020222040250	4 x 25	PZ2	1000	020222060700	6 x 70	PZ3	200
020222040300	4 x 30	PZ2	1000	020222060800	6 x 80	PZ3	100
020222040350	4 x 35	PZ2	1000	020222060900	6 x 90	PZ3	100
020222040400	4 x 40	PZ2	1000	020222061000	6 x 100	PZ3	100
020222040450	4 x 45	PZ2	500	020222061100	6 x 110	PZ3	100
020222040500	4 x 50	PZ2	500	020222061200	6 x 120	PZ3	100
020222040550	4 x 55	PZ2	500	020222061300	6 x 130	PZ3	100
020222040600	4 x 60	PZ2	500	020222061400	6 x 140	PZ3	100
020222040700	4 x 70	PZ2	250	020222061500	6 x 150	PZ3	100
020222450120	4,5 x 12	PZ2	1000	020222061600	6 x 160	PZ3	100



Mais medidas, matérias primas e acabamentos disponíveis em gama / More measurements, raw materials and finishes available in range / Plus de mesures, de matières premières et de finitions disponibles dans la gamme / Más medidas, materias primas y acabados disponibles en gama

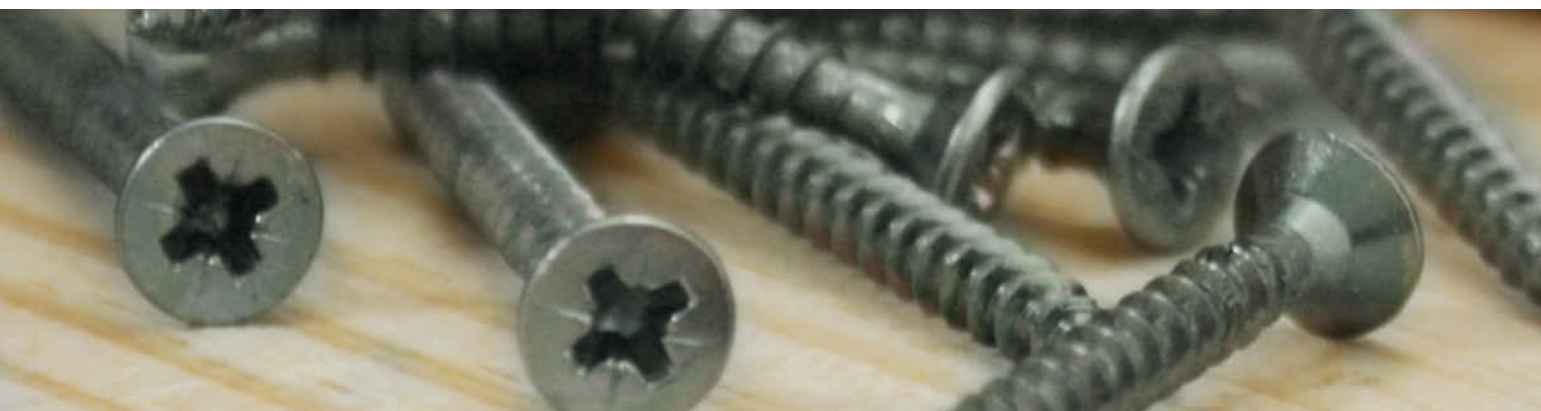



# PARAFUSOS PARA MADEIRA

Wood Screws / Vis pour Bois / Tornillos para Madera

## PCL 205

### Parafuso Aglomerado Cabeça Embeber. TORX

Chipboard screw with countersunk 90° head, 40° thread, special coating, TORX / Vis à bois. Tête fraiséé 90°. Lubrifiée. TORX / Tirafofudo de cabeça avellanada 90°, filete 40°, lubrificado. TORX

PCL 205

Passivado Amarelo / Yellow Zinc Plated / Bichomaté / Bicromatado



CÓDIGO CODE / CODE / CÓDIGO	DIMENSÕES SIZE / DIMENSIONS MEDIDA		EMBALAGEM QUANTITY / EMBALLAGE / EMBALAJE
020523030120	3 x 12	T10	1000
020523030160	3 x 16	T10	1000
020523030200	3 x 20	T10	1000
020523030250	3 x 25	T10	1000
020523030300	3 x 30	T10	1000
020523030350	3 x 35	T10	1000
020523030400	3 x 40	T10	1000
020523030450	3 x 45	T10	1000
020523350160	3,5 x 16	T15	1000
020523350200	3,5 x 20	T15	1000
020523350250	3,5 x 25	T15	1000
020523350300	3,5 x 30	T15	1000
020523350400	3,5 x 40	T15	1000
020523350450	3,5 x 45	T15	1000
020523350500	3,5 x 50	T15	1000
020523040160	4 x 16	T20	1000
020523040180	4 x 18	T20	1000
020523040200	4 x 20	T20	1000
020523040250	4 x 25	T20	1000
020523040300	4 x 30	T20	1000
020523040350	4 x 35	T20	1000
020523040400	4 x 40	T20	1000
020523040450	4 x 45	T20	500
020523040500	4 x 50	T20	500
020523040600	4 x 60	T20	500
020523450200	4,5 x 20	T20	1000
020523450250	4,5 x 25	T20	1000
020523450300	4,5 x 30	T20	1000

CÓDIGO CODE / CODE / CÓDIGO	DIMENSÕES SIZE / DIMENSIONS MEDIDA		EMBALAGEM QUANTITY / EMBALLAGE / EMBALAJE
020523450350	4,5 x 35	T20	500
020523450400	4,5 x 40	T20	1000
020523450450	4,5 x 45	T20	500
020523450500	4,5 x 50	T20	500
020523450600	4,5 x 60	T20	250
020523450700	4,5 x 70	T20	200
020523450800	4,5 x 80	T20	200
020523050250	5 x 25	T25	1000
020523050300	5 x 30	T25	1000
020523050350	5 x 35	T25	500
020523050400	5 x 40	T25	500
020523050450	5 x 45	T25	500
020523050500	5 x 50	T25	500
020523050600	5 x 60	T25	250
020523050700	5 x 70	T25	250
020523050800	5 x 80	T25	200
020523051200	5 x 120	T25	100
020523060400	6 x 40	T30	500
020523060500	6 x 50	T30	250
020523060600	6 x 60	T30	250
020523060700	6 x 70	T30	200
020523060800	6 x 80	T30	100
020523060900	6 x 90	T30	100
020523061000	6 x 100	T30	100
020523061100	6 x 110	T30	100
020523061200	6 x 120	T30	100
020523061600	6 x 160	T30	100

Mais medidas, matérias primas e acabamentos disponíveis em gama / More measurements, raw materials and finishes available in range / Plus de mesures, de matières premières et de finitions disponibles dans la gamme / Más medidas, materias primas y acabados disponibles en gama

PCL 205

Zincado / Zinc Plated / Zingué / Zincado



CÓDIGO CODE / CODE / CÓDIGO	DIMENSÕES SIZE / DIMENSIONS MEDIDA		EMBALAGEM QUANTITY / EMBALLAGE / EMBALAJE
020522030160	3 x 16	T10	1000
020522030200	3 x 20	T10	1000
020522030250	3 x 25	T10	1000
020522030300	3 x 30	T10	1000
020522350160	3,5 x 16	T15	1000
020522350200	3,5 x 20	T15	1000
020522350300	3,5 x 30	T15	1000
020522040160	4 x 16	T20	1000
020522040200	4 x 20	T20	1000
020522040250	4 x 25	T20	1000
020522040300	4 x 30	T20	1000
020522040350	4 x 35	T20	1000
020522040400	4 x 40	T20	1000
020522040450	4 x 45	T20	1000
020522040500	4 x 50	T20	1000
020522040600	4 x 60	T20	1000
020522450200	4,5 x 20	T20	1000
020522450250	4,5 x 25	T20	1000
020522450300	4,5 x 30	T20	1000
020522450350	4,5 x 35	T20	500

CÓDIGO CODE / CODE / CÓDIGO	DIMENSÕES SIZE / DIMENSIONS MEDIDA		EMBALAGEM QUANTITY / EMBALLAGE / EMBALAJE
020522450400	4,5 x 40	T20	1000
020522450450	4,5 x 45	T20	1000
020522450500	4,5 x 50	T20	1000
020522450600	4,5 x 60	T20	250
020522450700	4,5 x 70	T25	250
020522050300	5 x 30	T25	1000
020522050400	5 x 40	T25	1000
020522050450	5 x 45	T25	1000
020522050500	5 x 50	T25	1000
020522050600	5 x 60	T25	250
020522050700	5 x 70	T25	250
020522050800	5 x 80	T25	250
020522060500	6 x 50	T25	250
020522060600	6 x 60	T30	250
020522060700	6 x 70	T30	250
020522060800	6 x 80	T30	250
020522060900	6 x 90	T30	100
020522061000	6 x 100	T30	100
020522061800	6 x 180	T30	100

Mais medidas, matérias primas e acabamentos disponíveis em gama / More measurements, raw materials and finishes available in range / Plus de mesures, de matières premières et de finitions disponibles dans la gamme / Más medidas, materias primas y acabados disponibles en gama



## Parafuso autoperfurante para aglomerado cabeça embeber TORX

Self-drilling screw for wood. Countersunk head. Special thread with large pitch /  
Vis à bois autoperceuse, tête fraisée, filet spécial évitant les fissures / Tirafondo de cab. 90° avellanado, punta broca y paso de rosca más ancho

# PCL 9830

Zincado / Zingué / Zinc Plated / Zincado

PCL 9830



CÓDIGO CODE / CODE / CÓDIGO	DIMENSÕES SIZE / DIMENSIONS MEDIDA		EMBALAGEM QUANTITY / EMBALLAGE / EMBALAJE
983022350200	3,5 x 20	PZ2	500
983022350250	3,5 x 25	PZ2	500
983022350300	3,5 x 30	PZ2	500
983022350350	3,5 x 35	PZ2	500
983022350400	3,5 x 40	PZ2	500
983022350450	3,5 x 45	PZ2	500
983022350500	3,5 x 50	PZ2	500
983022350600	3,5 x 60	PZ2	200
983022350650	3,5 x 65	PZ2	200
983022040200	4,0 x 20	PZ2	500
983022040250	4,0 x 25	PZ2	500
983022040300	4,0 x 30	PZ2	500
983022040350	4,0 x 35	PZ2	500

CÓDIGO CODE / CODE / CÓDIGO	DIMENSÕES SIZE / DIMENSIONS MEDIDA		EMBALAGEM QUANTITY / EMBALLAGE / EMBALAJE
983022040400	4,0 x 40	PZ2	500
983022040450	4,0 x 45	PZ2	500
983022040500	4,0 x 50	PZ2	200
983022040600	4,0 x 60	PZ2	200
983022040650	4,0 x 65	PZ2	200
983022450200	4,5 x 20	PZ2	500
983022450250	4,5 x 25	PZ2	500
983022450350	4,5 x 35	PZ2	500
983022450400	4,5 x 40	PZ2	500
983022450450	4,5 x 45	PZ2	500
983022450500	4,5 x 50	PZ2	200
983022450600	4,5 x 60	PZ2	200
983022450650	4,5 x 65	PZ2	200



Mais medidas, matérias primas e acabamentos disponíveis em gama / More measurements, raw materials and finishes available in range / Plus de mesures, de matières premières et de finitions disponibles dans la gamme / Más medidas, materias primas y acabados disponibles en gama

## Parafuso aglomerado cabeça cilíndrica Pozidrive

Chipboard, panhead screw with 40° thread. Special coating /  
Vias à bois, tête cylindrique bombée, filet 40°. revêtement lubrifié / Tirafondo de cabeza alomada, filete de 40° lubrificado

# PCL 232

Zincado / Zingué / Zinc Plated / Zincado

PCL 232



CÓDIGO CODE / CODE / CÓDIGO	DIMENSÕES SIZE / DIMENSIONS MEDIDA		EMBALAGEM QUANTITY / EMBALLAGE / EMBALAJE
023222030100	3X10	PZ1	1000
023222030120	3X12	PZ1	1000
023222030160	3X16	PZ1	1000
023222030180	3X18	PZ1	1000
023222030200	3X20	PZ1	1000
023222030250	3X25	PZ1	1000
023222030300	3X30	PZ1	1000
023222030400	3X40	PZ1	1000
023222350100	3,5X10	PZ2	1000
023222350120	3,5X12	PZ2	1000
023222350160	3,5X16	PZ2	1000
023222350180	3,5X18	PZ2	1000
023222350200	3,5X20	PZ2	1000
023222350250	3,5X25	PZ2	1000
023222350300	3,5X30	PZ2	1000
023222350350	3,5X35	PZ2	1000
023222350400	3,5X40	PZ2	1000
023222040120	4X12	PZ2	1000
023222040160	4X16	PZ2	1000
023222040180	4X18	PZ2	1000
023222040200	4X20	PZ2	1000
023222040250	4X25	PZ2	1000
023222040300	4X30	PZ2	1000
023222040350	4X35	PZ2	1000
023222040400	4X40	PZ2	1000
023222040450	4X45	PZ2	500
023222040500	4X50	PZ2	500
023222040600	4X60	PZ2	500
023222450120	4,5X12	PZ2	1000

CÓDIGO CODE / CODE / CÓDIGO	DIMENSÕES SIZE / DIMENSIONS MEDIDA		EMBALAGEM QUANTITY / EMBALLAGE / EMBALAJE
023222450160	4,5X16	PZ2	1000
023222450200	4,5X20	PZ2	1000
023222450250	4,5X25	PZ2	1000
023222450300	4,5X30	PZ2	1000
023222450350	4,5X35	PZ2	1000
023222450400	4,5X40	PZ2	500
023222450450	4,5X45	PZ2	500
023222450500	4,5X50	PZ2	500
023222050120	5X12	PZ2	1000
023222050160	5X16	PZ2	1000
023222050200	5X20	PZ2	1000
023222050250	5X25	PZ2	1000
023222050300	5X30	PZ2	1000
023222050350	5X35	PZ2	500
023222050400	5X40	PZ2	500
023222050450	5X45	PZ2	500
023222050500	5X50	PZ2	500
023222050600	5X60	PZ2	250
023222050700	5X70	PZ2	250
023222050800	5X80	PZ2	200
023222060350	6X35	PZ3	500
023222060400	6X40	PZ3	500
023222060450	6X45	PZ3	500
023222060500	6X50	PZ3	250
023222060600	6X60	PZ3	250
023222060700	6X70	PZ3	200
023222060800	6X80	PZ3	100
023222060900	6X90	PZ3	100
023222061000	6X100	PZ3	100



Mais medidas, matérias primas e acabamentos disponíveis em gama / More measurements, raw materials and finishes available in range / Plus de mesures, de matières premières et de finitions disponibles dans la gamme / Más medidas, materias primas y acabados disponibles en gama



# PARAFUSOS PARA MADEIRA

Wood Screws / Vis pour Bois / Tornillos para Madera

## DIN 571

### Parafuso Tirefond

Coach wood screw with hexagon head / Tirefond à visser pour bois et aggloméré, tête hexagonale / Tornillo con rosca para madera y aglomerado y cabeza hexagonal

DIN 571

Zincado / Zinc Plated / Zingué / Zincado



CÓDIGO CODE / CODE / CÓDIGO	DIMENSÕES SIZE / DIMENSIONS MEDIDA	EMBALAGEM QUANTITY / EMBALLAGE / EMBALAJE
057112050300	5 x 30	200
057112050400	5 x 40	200
057112060250	6 x 25	200
057112060300	6 x 30	200
057112060350	6 x 35	200
057112060400	6 x 40	200
057112060450	6 x 45	200
057112060500	6 x 50	200
057112060550	6 x 55	200
057112060600	6 x 60	200
057112060650	6 x 65	100
057112060700	6 x 70	100
057112060750	6 x 75	100
057112060800	6 x 80	100
057112060900	6 x 90	100
057112061000	6 x 100	100
057112061100	6 x 110	100
057112061200	6 x 120	100
057112061300	6 x 130	100
057112061400	6 x 140	100
057112070300	7 x 30	200
057112070350	7 x 35	200
057112070400	7 x 40	200
057112070500	7 x 50	200
057112070550	7 x 55	200
057112070600	7 x 60	200
057112070700	7 x 70	100
057112070800	7 x 80	100
057112070900	7 x 90	100
057112071000	7 x 100	100
057112071100	7 x 110	100
057112071200	7 x 120	50
057112071300	7 x 130	50
057112071400	7 x 140	50
057112071500	7 x 150	50
057112071600	7 x 160	50
057112071800	7 x 180	50
057112072000	7 x 200	50
057112080300	8 x 30	200

CÓDIGO CODE / CODE / CÓDIGO	DIMENSÕES SIZE / DIMENSIONS MEDIDA	EMBALAGEM QUANTITY / EMBALLAGE / EMBALAJE
057112080350	8 x 35	200
057112080400	8 x 40	200
057112080500	8 x 50	100
057112080600	8 x 60	100
057112080700	8 x 70	100
057112080800	8 x 80	100
057112080900	8 x 90	100
057112081000	8 x 100	100
057112081200	8 x 120	50
057112081300	8 x 130	50
057112081400	8 x 140	50
057112081500	8 x 150	50
057112081600	8 x 160	50
057112081800	8 x 180	50
057112082000	8 x 200	50
057112100300	10 x 30	100
057112100400	10 x 40	100
057112100500	10 x 50	100
057112100600	10 x 60	50
057112100700	10 x 70	50
057112100750	10 x 75	50
057112100800	10 x 80	50
057112100900	10 x 90	50
057112101000	10 x 100	50
057112101100	10 x 110	50
057112101200	10 x 120	25
057112101400	10 x 140	25
057112101600	10 x 160	25
057112102000	10 x 200	100
057112120500	12 x 50	50
057112120600	12 x 60	50
057112120700	12 x 70	50
057112120800	12 x 80	25
057112120900	12 x 90	25
057112121000	12 x 100	25
057112121200	12 x 120	25
057112121400	12 x 140	25
057112121800	12 x 180	25
057112122000	12 x 200	25

Mais medidas, matérias primas e acabamentos disponíveis em gama / More measurements, raw materials and finishes available in range / Plus de mesures, de matières premières et de finitions disponibles dans la gamme / Más medidas, materias primas y acabados disponibles en gama





Inoxidable A2 / Inoxydable A2 / Stainless Steel A2 / Aço Inox A2

DIN 571



CÓDIGO CODE / CODE / CÓDIGO	DIMENSÕES SIZE / DIMENSIONS MEDIDA	EMBALAGEM QUANTITY / EMBALLAGE / EMBALAJE
057161060300	6 x 30	200
057161060400	6 x 40	200
057161060450	6 x 45	200
057161060500	6 x 50	200
057161060600	6 x 60	100
057161060700	6 x 70	100
057161060800	6 x 80	100
057161060900	6 x 90	100
057161071000	7 x 100	100
057161071100	7 x 110	100
057161080400	8 x 40	100
057161080500	8 x 50	100
057161080600	8 x 60	100
057161080700	8 x 70	100
057161080750	8 x 75	100
057161080800	8 x 80	50
057161081000	8 x 100	100
057161081200	8 x 120	50
057161081400	8 x 140	50
057161081500	8 x 150	50
057161100600	10 x 60	50
057161100800	10 x 80	50
057161101000	10 x 100	50
057161101200	10 x 120	50
057161101400	10 x 140	25
057161120500	12 x 50	50
057161120700	12 x 70	25
057161120800	12 x 80	25

Mais medidas, matérias primas e acabamentos disponíveis em gama / More measurements, raw materials and finishes available in range / Plus de mesures, de matières premières et de finitions disponibles dans la gamme / Más medidas, materias primas y acabados disponibles en gama

## Parafuso Auto-Perfurante Cabeça de Embeter Phillips com Alhetas

Self-drilling screw flat head, with two wings, countersunkhead, Phillips recess / Vis autoperceuse, pointe foreuse à 2 ailettes, tête fraisée, Phillips / Tornillo autotaladrante con broca de dos alas, cabeza avellanada y huella Phillips

# PCL 9800

Zincado / Zingú / Zinc Plated / Zincado

PCL 9800



CÓDIGO CODE / CODE / CÓDIGO	DIMENSÕES SIZE / DIMENSIONS MEDIDA	+	ESP. MÁX A FIXAR MAX FIXTURE THICKNESS / ÉPAISSEUR MAX À FIXER/ ESP. MÁX A FIJAR	CAPACIDADE DE PERFURAÇÃO DRILL CAPACITY / CAPACITÉ DE PERCADE / CAPACIDAD DE TALADRADO	EMBALAGEM QUANTITY / EMBALLAGE / EMBALAJE
980022480320	4,8 x 32	PH2	13,7	4	500
980022480380	4,8 x 38	PH2	19,7	4	500
980022480450	4,8 x 45	PH2	26,7	4	500
980022550380	5,5 x 38	PH2	16,60	5	500
980022550500	5,5 x 50	PH2	28,60	5	250
980022550600	5,5 x 60	PH2	38,60	5	250
980022630500	6,3 x 50	PH2	28,10	6	250
980022630630	6,3 x 63	PH2	41,10	6	250

Mais medidas, matérias primas e acabamentos disponíveis em gama / More measurements, raw materials and finishes available in range / Plus de mesures, de matières premières et de finitions disponibles dans la gamme / Más medidas, materias primas y acabados disponibles en gama

## GAMA DISPONÍVEL / Available range / Gamme disponible / Gama disponible

**PF. ROSCA MADEIRA  
E AGLOMERADO**  
/ WOOD AND CHIPBOARD SCREWS  
/ VIS À BOIS  
/ TORNILLOS ROSCA MADERA  
Y AGLOMERADO

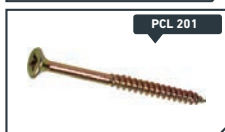
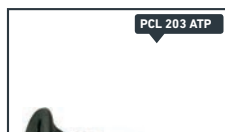

**CATÁLOGO TÉCNICO**  
FIXING CATALOGUE  
/ CATALOGUE TECHNIQUE  
/ CATÁLOGO TÉCNICO





**O SEU FORNECEDOR DE SEMPRE,  
ONDE ESTIVER!**

*/ Your ever-ready supplier, wherever you are! / Votre fournisseur de toujours, où que vous soyez! / Su proveedor de siempre, donde esté!*

[HTTP://STORE.PECOL.PT/](http://store.pecol.pt/)

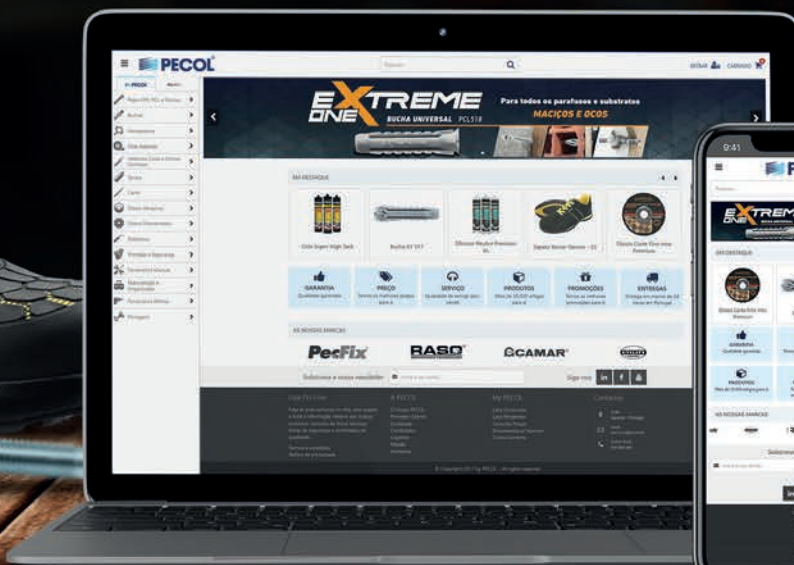



# REBITES

*BLIND RIVETS*  
*RIVETS*  
*REMACHES*



# REBITES

Blind rivets / Rivets / Remaches

## DIN 7337

### Rebite Cabeça Boleada

Blind rivet / Rivet aveugle à tête plate / Ciego con cabeza alomada

DIN 7337

Aço / Steel / Acier / Acero

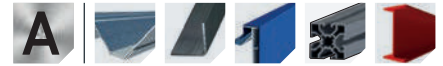

CÓDIGO CODE / CODE / CÓDIGO	DIMENSÕES SIZE / DIMENSIONS MEDIDA	ESP. MAX A FIXAR MAX FIXTURE THICKNESS / ÉPAISSEUR MAX À FIXER/ ESP. MÁX A FIJAR	EMBALAGEM QUANTITY / EMBALLAGE / EMBALAJE
733721030060	3 x 6	1-3.5	1000
733721030080	3 x 8	3.5-5	1000
733721030100	3 x 10	4.5-7	1000
733721030120	3 x 12	7-9	1000
733721320060	3.2 x 6	1.5-3.5	1000
733721320080	3.2 x 8	3-5	1000
733721320100	3.2 x 10	5-7	1000
733721320120	3.2 x 12	7-9	1000
733721320140	3.2 x 14	8-10	1000
733721040060	4 x 6	1.5-3.5	1000
733721040080	4 x 8	3-5	1000
733721040090	4 x 9	4-6	1000
733721040100	4 x 10	5-6.5	1000
733721040110	4 x 11	5.5-7.5	1000
733721040120	4 x 12	6.5-8.5	1000
733721040140	4 x 14	8.5-10.5	1000
733721040160	4 x 16	10.5-12.5	500
733721040200	4 x 20	14.5-16.5	500
733721040240	4 x 24	16.5-21.5	500
733721050060	5 x 6	0.5-3	1000
733721050080	5 x 8	3-4.5	1000
733721050100	5 x 10	4.5-6	1000
733721050120	5 x 12	6-8	500
733721050140	5 x 14	8-10	500
733721050160	5 x 16	10-12	500
733721050180	5 x 18	12-14	500
733721050200	5 x 20	14-16	500
733721050220	5 x 22	15-18	500
733721050240	5 x 24	15.5-20.5	500
733721050250	5 x 25	16-21	500
733721050260	5 x 26	17-22	500
733721060120	6 x 12	6-8	500
733721060220	6 x 22	14-18	250

Mais matérias primas e acabamentos disponíveis em gama / More raw materials and finishes available in range / Plus de matières premières et de finitions disponibles dans la gamme / Más materias primas y acabados disponibles en gama

DIN 7337

Cobre / Cooper / Cúivre / Cobre



CÓDIGO CODE / CODE / CÓDIGO	DIMENSÕES SIZE / DIMENSIONS MEDIDA	ESP. MAX A FIXAR MAX FIXTURE THICKNESS / ÉPAISSEUR MAX À FIXER/ ESP. MÁX A FIJAR	EMBALAGEM QUANTITY / EMBALLAGE / EMBALAJE
733791030060	3 x 6	1-3.5	1000
733791030080	3 x 8	3.5-5	1000
733791030100	3 x 10	4.5-7	1000
733791030120	3 x 12	7-9	1000
733791320060	3.2 x 6	1.5-3.5	1000
733791320070	3.2 x 7	2-4	1000
733791320080	3.2 x 8	3-5	1000
733791320100	3.2 x 10	5-7	1000
733791320120	3.2 x 12	7-9	1000
733791320140	3.2 x 14	8-10	1000
733791040060	4 x 6	1.5-3.5	1000
733791040080	4 x 8	3-5	1000
733791040100	4 x 10	5-6.5	1000
733791040110	4 x 11	5.5-7.5	1000
733791040120	4 x 12	6.5-8.5	1000
733791040140	4 x 14	8.5-10.5	1000
733791040160	4 x 16	10.5-12.5	500
733791040180	4 x 18	12.5-14.5	500
733791050060	5 x 6	0.5-3	500
733791050080	5 x 8	3-4.5	500
733791050100	5 x 10	4.5-6	500
733791050120	5 x 12	6-8	500
733791050140	5 x 14	8-10	500
733791050160	5 x 16	10-12	500
733791050180	5 x 18	12-14	500
733791050260	5 x 26	17-22	500

Mais matérias primas e acabamentos disponíveis em gama / More raw materials and finishes available in range / Plus de matières premières et de finitions disponibles dans la gamme / Más materias primas y acabados disponibles en gama



CÓDIGO CODE / CODE / CÓDIGO	DIMENSÕES SIZE / DIMENSIONS MEDIDA	ESP. MAX A FIXAR	EMBALAGEM
		MAX FIXTURE THICKNESS / ÉPAISSEUR MAX À FIXER/ ESP. MÁX A FIJAR	QUANTITY / EMBALLAGE / EMBALAJE
733781240050	2.4 x 5	1-2	1000
733781240060	2.4 x 6	2-4	1000
733781240080	2.4 x 8	4-6	1000
733781240100	2.4 x 10	6-8	1000
733781240140	2.4 x 14	10-12	1000
733781030050	3 x 5	0.5-2.5	1000
733781030060	3 x 6	1-3.5	1000
733781030070	3 x 7	1.5-4.5	1000
733781030080	3 x 8	3.5-5	1000
733781030090	3 x 9	4.5-6.5	1000
733781030100	3 x 10	4.5-7	1000
733781030120	3 x 12	7-9	1000
733781030140	3 x 14	9-11	1000
733781030160	3 x 16	11-13	1000
733781030180	3 x 18	10-14	1000
733781320060	3.2 x 6	1.5-3.5	1000
733781320070	3.2 x 7	2-4	1000
733781320090	3.2 x 9	3.5-5.5	1000
733781320100	3.2 x 10	5-7	1000
733781320120	3.2 x 12	7-9	1000
733781320140	3.2 x 14	8-10	1000
733781320160	3.2 x 16	9-13	1000
733781320180	3.2 x 18	12-15	1000
733781320200	3.2 x 20	15-17	1000
733781040050	4 x 5	0.5-2.5	1000
733781040060	4 x 6	1.5-3.5	1000
733781040070	4 x 7	3-4.5	1000
733781040080	4 x 8	3-5	1000
733781040090	4 x 9	4-6	1000
733781040100	4 x 10	5-6.5	1000
733781040120	4 x 12	6.5-8.5	1000
733781040140	4 x 14	8.5-10.5	1000
733781040160	4 x 16	10.5-12.5	500
733781040180	4 x 18	12.5-14.5	500
733781040200	4 x 20	14.5-16.5	500
733781040220	4 x 22	15.5-20.5	500
733781040240	4 x 24	16.5-21.5	500
733781040300	4 x 30	21.5-26	500
733781050060	5 x 6	0.5-3	1000
733781050070	5 x 7	2-4	1000
733781050080	5 x 8	3-4.5	1000
733781050090	5 x 9	3.5-5	1000
733781050100	5 x 10	4.5-6	500
733781050120	5 x 12	6-8	500
733781050140	5 x 14	8-10	500
733781050160	5 x 16	10-12	500
733781050180	5 x 18	12-14	500
733781050200	5 x 20	14-16	500
733781050220	5 x 22	15-18	500
733781050240	5 x 24	15.5-20.5	500
733781050250	5 x 25	16-21	500
733781050260	5 x 26	17-22	500
733781050270	5 x 27	18-23	250
733781050300	5 x 30	21-25	250
733781050350	5 x 35	25-30	250
733781050400	5 x 40	30-35	200
733781050450	5 x 45	35-40	200
733781060100	6 x 10	4-6	500
733781060120	6 x 12	6-8	500
733781060180	6 x 18	11-13	250
733781060200	6 x 20	13-15	250
733781060220	6 x 22	14-18	250
733781060250	6 x 25	15-20	250
733781060260	6 x 26	16-21	250
733781060300	6 x 30	20-24	250



Mais matérias primas e acabamentos disponíveis em gama / More raw materials and finishes available in range / Plus de matières premières et de finitions disponibles dans la gamme / Más materias primas y acabados disponibles en gama



# REBITES

Blind rivets / Rivets / Remaches

DIN 7337

Alumínio - lacada a cor / Aluminum - Colours / Aluminium - laquée, couleurs / Aluminio - lacada a color

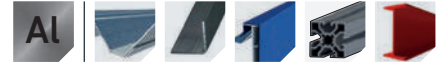

**COD 82**  
Branco / White / Blanc / Blanco



**COD 86**  
Cinza / Grey / Gris / Gris



**COD 87**  
Preto / Black / Noir / Negro



**COD 89**  
Castanho / Brown / Brun / Marrón



**COD 85**  
Verde / Green / Vert / Verde



**COD 90**  
Azul / Blue / Bleu / Azul



**COD 88**  
Bronze / Bronze / Bronze / Bronce

**i** Outras cores disponíveis sob consulta.  
/ More colors available on request  
/ Autres couleurs disponibles sur demande  
/ Más colores disponibles bajo pedido



**EXEMPLO**  
Rebite 5x20 Verde  
7337 **85** 050200

**EXAMPLE**  
Rivets 5x20 Green  
7337 **85** 050200

**EJEMPLO**  
Rivets 5x20 Green  
7337 **85** 050200

**EJEMPLO**  
Remache 5x20 Verde  
7337 **85** 050200

CÓDIGO CODE / CODE / CÓDIGO	DIMENSÕES SIZE / DIMENSIONS MEDIDA	ESP. MAX A FIXAR	EMBALAGEM
		MAX FIXTURE THICKNESS / ÉPAISSEUR MAX À FIXER / ESP. MÁX A FIJAR	QUANTITY / EMBALLAGE / EMBALAJE
7337 ... 240050	2,4 x 5	1-2	1000
7337 ... 240060	2,4 x 6	2-4	1000
7337 ... 240080	2,4 x 8	4-6	1000
7337 ... 240100	2,4 x 10	6-8	1000
7337 ... 240140	2,4 x 14	10-12	1000
7337 ... 030050	3 x 5	0,5-2,5	1000
7337 ... 030060	3 x 6	1-3,5	1000
7337 ... 030070	3 x 7	1,5-4,5	1000
7337 ... 030080	3 x 8	3,5-5	1000
7337 ... 030090	3 x 9	4,5-6,5	1000
7337 ... 030100	3 x 10	4,5-7	1000
7337 ... 030120	3 x 12	7-9	1000
7337 ... 030140	3 x 14	9-11	1000
7337 ... 030160	3 x 16	11-13	1000
7337 ... 030180	3 x 18	10-14	1000
7337 ... 320060	3,2 x 6	1,5-3,5	1000
7337 ... 320070	3,2 x 7	2-4	1000
7337 ... 320090	3,2 x 9	3,5-5,5	1000
7337 ... 320100	3,2 x 10	5-7	1000
7337 ... 320120	3,2 x 12	7-9	1000
7337 ... 320140	3,2 x 14	8-10	1000
7337 ... 320160	3,2 x 16	9-13	1000
7337 ... 320180	3,2 x 18	12-15	1000
7337 ... 320200	3,2 x 20	15-17	1000
7337 ... 040050	4 x 5	0,5-2,5	1000
7337 ... 040060	4 x 6	1,5-3,5	1000
7337 ... 040070	4 x 7	3-4,5	1000
7337 ... 040080	4 x 8	3-5	1000
7337 ... 040090	4 x 9	4-6	1000
7337 ... 040100	4 x 10	5-6,5	1000
7337 ... 040120	4 x 12	6,5-8,5	1000
7337 ... 040140	4 x 14	8,5-10,5	1000
7337 ... 040160	4 x 16	10,5-12,5	500
7337 ... 040180	4 x 18	12,5-14,5	500
7337 ... 040200	4 x 20	14,5-16,5	500
7337 ... 040220	4 x 22	15,5-20,5	500
7337 ... 040240	4 x 24	16,5-21,5	500
7337 ... 040300	4 x 30	21,5-26	500
7337 ... 050060	5 x 6	0,5-3	1000
7337 ... 050070	5 x 7	2-4	1000
7337 ... 050080	5 x 8	3-4,5	1000
7337 ... 050090	5 x 9	3,5-5	1000
7337 ... 050100	5 x 10	4,5-6	500
7337 ... 050120	5 x 12	6-8	500
7337 ... 050140	5 x 14	8-10	500
7337 ... 050160	5 x 16	10-12	500
7337 ... 050180	5 x 18	12-14	500
7337 ... 050200	5 x 20	14-16	500
7337 ... 050220	5 x 22	15-18	500
7337 ... 050240	5 x 24	15,5-20,5	500
7337 ... 050250	5 x 25	16-21	500
7337 ... 050260	5 x 26	17-22	500
7337 ... 050270	5 x 27	18-23	250
7337 ... 050300	5 x 30	21-25	250
7337 ... 050350	5 x 35	25-30	250
7337 ... 050400	5 x 40	30-35	200
7337 ... 050450	5 x 45	35-40	200
7337 ... 060100	6 x 10	4-6	500
7337 ... 060120	6 x 12	6-8	500
7337 ... 060180	6 x 18	11-13	250
7337 ... 060200	6 x 20	13-15	200
7337 ... 060220	6 x 22	14-18	250
7337 ... 060250	6 x 25	15-20	25
7337 ... 060260	6 x 26	16-21	250
7337 ... 060300	6 x 30	20-24	250

Mais matérias primas e acabamentos disponíveis em gama / More raw materials and finishes available in range / Plus de matières premières et de finitions disponibles dans la gamme / Más materias primas y acabados disponibles en gama



Inoxidable A2 / Inoxydable A2 / Stainless steel A2 / Aço inox A2

DIN 7337

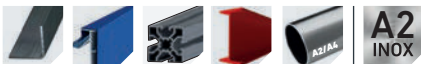

CÓDIGO CODE / CODE / CÓDIGO	DIMENSÕES SIZE / DIMENSIONS MEDIDA	ESP. MAX A FIXAR MAX FIXTURE THICKNESS / ÉPAISSEUR MAX À FIXER/ ESP. MÁX A FIJAR		EMBALAGEM QUANTITY / EMBALLAGE / EMBALAJE
733761030060	3 x 6	1-3.5	1000	
733761030080	3 x 8	3.5-5	1000	
733761030100	3 x 10	4.5-7	1000	
733761320060	3.2 x 6	1.5-3.5	1000	
733761320080	3.2 x 8	3-5	1000	
733761320100	3.2 x 10	5-7	1000	
733761320120	3.2 x 12	7-9	1000	
733761040060	4 x 6	1.5-3.5	1000	
733761040080	4 x 8	3-5	1000	
733761040100	4 x 10	5-6.5	500	
733761040120	4 x 12	6.5-8.5	500	
733761040140	4 x 14	8.5-10.5	500	
733761040160	4 x 16	10.5-12.5	500	
733761040180	4 x 18	12.5-14.5	500	
733761040200	4 x 20	14.5-16.5	500	
733761050080	5 x 8	3-4.5	500	
733761050100	5 x 10	4.5-6	500	
733761050120	5 x 12	6-8	500	
733761050140	5 x 14	8-10	500	
733761050160	5 x 16	10-12	500	
733761050180	5 x 18	12-14	500	
733761050200	5 x 20	14-16	500	
733761050300	5 x 30	21-25	250	
733761060150	6 x 15	9-10.5	250	



Mais matérias primas e acabamentos disponíveis em gama / More raw materials and finishes available in range / Plus de matières premières et de finitions disponibles dans la gamme / Más materias primas y acabados disponibles en gama

## Rebite Pop Cabeça de Embeber

Countersunk head blind rivet / Rivet aveugle tête fraisée / Remache ciego con cabeza avellanada

# PCL 7336

Aluminio / Aluminium / Aluminum / Alumínio

PCL 7336



CÓDIGO CODE / CODE / CÓDIGO	DIMENSÕES SIZE / DIMENSIONS MEDIDA	ESP. MAX A FIXAR MAX FIXTURE THICKNESS / ÉPAISSEUR MAX À FIXER/ ESP. MÁX A FIJAR		EMBALAGEM QUANTITY / EMBALLAGE / EMBALAJE
733681030060	3 x 6	1.5-3.5	1000	
733681030080	3 x 8	3.5-5.5	1000	
733681030100	3 x 10	5.5-7	1000	
733681030120	3 x 12	7-9	1000	
733681030140	3 x 14	9-11	1000	
733681030160	3 x 16	11-13	1000	
733681320060	3.2 x 6	1.5-3.5	1000	
733681320080	3.2 x 8	3.5-5.5	1000	
733681320090	3.2 x 9	4.5-6.5	1000	
733681320120	3.2 x 12	7-9	1000	
733681040060	4 x 6	1.5-3	1000	
733681040070	4 x 7	2-3.5	1000	
733681040080	4 x 8	3-5	1000	
733681040090	4 x 9	4-6	1000	
733681040100	4 x 10	5-6.5	1000	
733681040120	4 x 12	6.5-8.5	1000	
733681040140	4 x 14	8.5-10.5	500	
733681040160	4 x 16	10.5-12.5	500	
733681040200	4 x 20	14.5-16.5	500	
733681050080	5 x 8	3-4.5	500	
733681050100	5 x 10	4.5-6	500	
733681050120	5 x 12	6-8	500	
733681050140	5 x 14	8-10	500	
733681050160	5 x 16	10-12	500	
733681050180	5 x 18	12-14	500	
733681050200	5 x 20	14-16	500	
733681050220	5 x 22	15-20	500	
733681050300	5 x 30	21-25	500	



Mais matérias primas e acabamentos disponíveis em gama / More raw materials and finishes available in range / Plus de matières premières et de finitions disponibles dans la gamme / Más materias primas y acabados disponibles en gama



# REBITES

Blind rivets / Rivets / Remaches

## PCL 7331

### Rebite Estanque

Blind sealed head rivet / Rivet à tête étanche / Remache cabeça estanco

PCL 7331

Alumínio / Aluminum / Aluminium / Aluminio

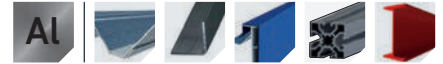

CÓDIGO CODE / CODE / CÓDIGO	DIMENSÕES SIZE / DIMENSIONS MEDIDA	ESP. MAX A FIXAR MAX FIXTURE THICKNESS / ÉPAISSEUR MAX À FIXER/ ESP. MÁX A FIJAR	EMBALAGEM QUANTITY / EMBALLAGE / EMBALAJE
733181030100	3 x 10	4-5.5	500
733181040100	4 x 10	4-5.5	500
733181040125	4 x 12.5	6.5-8.0	500
733181040130	4 x 13	7-8.5	500
733181480160	4.8 x 16	9.5-11.0	500
733181480180	4.8 x 18	11.0-13.0	500
733181050100	5 x 10	4-5.5	500
733181050110	5 x 11	5-6.5	500
733181050120	5 x 12	5.5-7.5	500
733181050140	5 x 14	7.5-9	500
733181050150	5 x 15	9-10.5	500
733181050180	5 x 18	11-13	500

Mais matérias primas e acabamentos disponíveis em gama / More raw materials and finishes available in range / Plus de matières premières et de finitions disponibles dans la gamme / Más materias primas y acabados disponibles en gama

## PCL 7332

### Rebite Multigrip

Multigrip rivet / Rivet multi-serrage / Remache multigrip

PCL 7332

Alumínio / Aluminum / Aluminium / Aluminio



CÓDIGO CODE / CODE / CÓDIGO	DIMENSÕES SIZE / DIMENSIONS MEDIDA	ESP. MAX A FIXAR MAX FIXTURE THICKNESS / ÉPAISSEUR MAX À FIXER/ ESP. MÁX A FIJAR	EMBALAGEM QUANTITY / EMBALLAGE / EMBALAJE
733281320080	3.2 x 8	0.5-5.0	500
733281040130	4 x 13	4-9	500
733281050110	5 x 11	1.5-6.5	500
733281050150	5 x 15	4.5-11	500
733281050170	5 x 17	6.5-13	500
733281050190	5 x 19	8.5-16	500
733281050250	5 x 25	12.5-20	500

Mais matérias primas e acabamentos disponíveis em gama / More raw materials and finishes available in range / Plus de matières premières et de finitions disponibles dans la gamme / Más materias primas y acabados disponibles en gama

## PCL 7333

### Rebite Flor

Peeltype blind rivet / Rivet à tête éclaté / Cabeza alomada - Flor

PCL 7333

Alumínio / Aluminum / Aluminium / Aluminio



CÓDIGO CODE / CODE / CÓDIGO	DIMENSÕES SIZE / DIMENSIONS MEDIDA	ESP. MAX A FIXAR MAX FIXTURE THICKNESS / ÉPAISSEUR MAX À FIXER/ ESP. MÁX A FIJAR	EMBALAGEM QUANTITY / EMBALLAGE / EMBALAJE
733381040100	4 x 10	6	1000
733381040120	4 x 12	8	1000
733381040140	4 x 14	10	1000
733381040160	4 x 16	12	1000
733381040180	4 x 18	14	500
733381040200	4 x 20	16	500
733381050100	5 x 10	5	500
733381050120	5 x 12	7	500
733381050160	5 x 16	11	500
733381050180	5 x 18	13	500
733381050200	5 x 20	15	500
733381050220	5 x 22	17	500
733381050240	5 x 24	19	500
733381050300	5 x 30	25	200
733381050450	5 x 45	37	200

Mais matérias primas e acabamentos disponíveis em gama / More raw materials and finishes available in range / Plus de matières premières et de finitions disponibles dans la gamme / Más materias primas y acabados disponibles en gama





## Rebite de Aba Larga

Rivet large head / Rivet à tête plate large / Remache cabeça ancha K10 - K14

# PCL 7334

Alumínio / Aluminium / Aluminum / Aluminio

PCL 7334



CÓDIGO CODE / CODE / CÓDIGO	DIMENSÕES SIZE / DIMENSIONS MEDIDA	ESP. MAX A FIXAR		EMBALAGEM QUANTITY / EMBALLAGE / EMBALAJE
		MAX FIXTURE THICKNESS / ÉPAISSEUR MAX À FIXER/ ESP. MÁX A FIJAR		
733481040100	4 x 10 K10	5.0-6.5		1000
733481040120	4 x 12 K10	6.5-8.5		500
733481040160	4 x 16 K10	10.5-12.5		500
733481040200	4 x 20 K10	14.5-16.5		500
733481050300	5 x 30 K10	21-25		250
733481050100	5 x 10 K14	4.5-6		500
733481050120	5 x 12 K14	6-8		500
733481050140	5 x 14 K14	8-10		500
733481050160	5 x 16 K14	10-12		250
733481050180	5 x 18 K14	12-14		250
733481050200	5 x 20 K14	14-16		250
733481050220	5 x 22 K14	15-18		250
733481050240	5 x 24 K14	16-21		250
733481050301	5 x 30 K14	21-25		250

Mais matérias primas e acabamentos disponíveis em gama / More raw materials and finishes available in range / Plus de matières premières et de finitions disponibles dans la gamme / Más materias primas y acabados disponibles en gama



K10 4 / 5

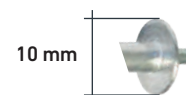

K14 5

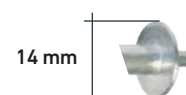

## Rebite de Aba Larga

Rivet large head / Rivet à tête plate large / Remache cabeça ancha K16

# PCL 7335

Alumínio / Aluminium / Aluminum / Aluminio

PCL 7335



CÓDIGO CODE / CODE / CÓDIGO	DIMENSÕES SIZE / DIMENSIONS MEDIDA	ESP. MAX A FIXAR		EMBALAGEM QUANTITY / EMBALLAGE / EMBALAJE
		MAX FIXTURE THICKNESS / ÉPAISSEUR MAX À FIXER/ ESP. MÁX A FIJAR		
733581050100	5.0 x 10 K16	3-6		500
733581050120	5.0 x 12 K16	6-8		500
733581050140	5.0 x 14 K16	8-10		250
733581050160	5.0 x 16 K16	10-12		250
733581050180	5.0 x 18 K16	12-14		250
733581050200	5.0 x 20 K16	13-15		250
733581050220	5.0 x 22 K16	15-18		250
733581050240	5.0 x 24 K16	17-20		250
733581050260	5.0 x 26 K16	19-22		250
733581050270	5.0 x 27 K16	20-23		250
733581050300	5.0 x 30 K16	23-25		250
733581060100	6.0 x 10 K16	4-7		250

Mais matérias primas e acabamentos disponíveis em gama / More raw materials and finishes available in range / Plus de matières premières et de finitions disponibles dans la gamme / Más materias primas y acabados disponibles en gama

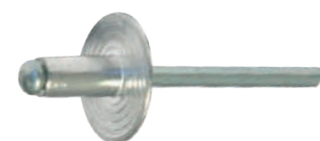

K16 5.0 / 6.0

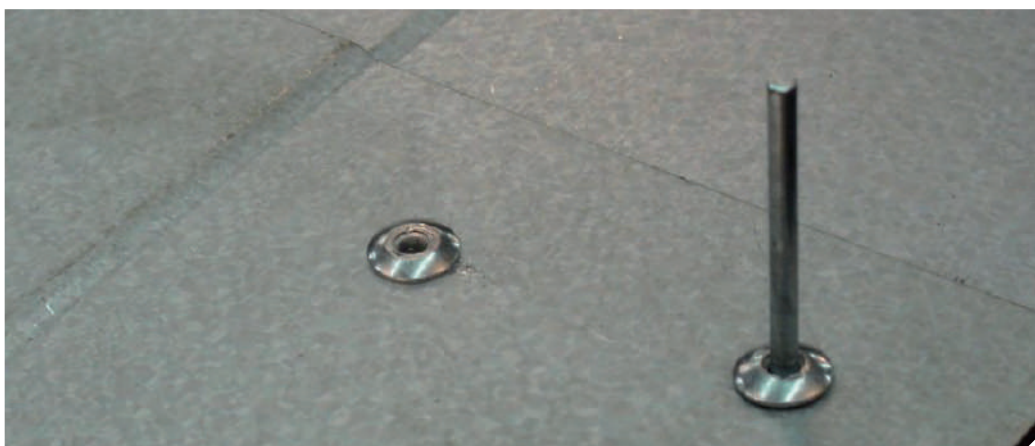
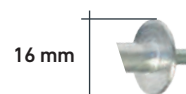



# REBITES

Blind rivets / Rivets / Remaches

## PCL 7338

### Rebite Semi Furado Cabeça Oval

Round head semi tubular rivet / Rivet semi-tubulaire tête ronde / Remache semi agujereado cabeza redonda

PCL 7338

Zincado / Zinc plated / Zinqué / Zincado

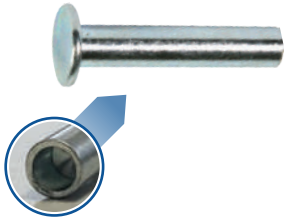
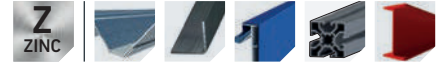

CÓDIGO CODE / CODE / CÓDIGO	DIMENSÕES SIZE / DIMENSIONS MEDIDA	EMBALAGEM QUANTITY / EMBALLAGE / EMBALAJE
733812040050	4 x 5	10000
733812040060	4 x 6	10000
733812040100	4 x 10	10000
733812040140	4 x 14	10000
733812040160	4 x 16	7500
733812040230	4 x 23	5000
733812040240	4 x 24	5000
733812040260	4 x 26	5000
733812040280	4 x 28	5000
733812040470	4 x 47	2500
733812050060	5 x 6	10000
733812050080	5 x 8	7500
733812050090	5 x 9	7500
733812050100	5 x 10	7500
733812050120	5 x 12	5000
733812050130	5 x 13	5000
733812050140	5 x 14	5000
733812050160	5 x 16	5000
733812050180	5 x 18	5000
733812050190	5 x 19	4000
733812050200	5 x 20	4000
733812050210	5 x 21	4000
733812050220	5 x 22	4000
733812050230	5 x 23	4000
733812050240	5 x 24	3500
733812050250	5 x 25	3000
733812050260	5 x 26	3000
733812050280	5 x 28	3000
733812050300	5 x 30	3000
733812050320	5 x 32	2500
733812050330	5 x 33	2500
733812050340	5 x 34	2500
733812050360	5 x 36	2500
733812050380	5 x 38	2000
733812050400	5 x 40	2000
733812050420	5 x 42	2000
733812050430	5 x 43	2000
733812050440	5 x 44	2000
733812050450	5 x 45	2000
733812050460	5 x 46	2000
733812050480	5 x 48	1500
733812050500	5 x 50	1500
733812050520	5 x 52	1500
733812050540	5 x 54	1000
733812050560	5 x 56	1250
733812050580	5 x 58	1250
733812050600	5 x 60	1250
733812050620	5 x 62	1250
733812050660	5 x 66	1000
733812050670	5 x 67	1250

Mais matérias primas e acabamentos disponíveis em gama / More raw materials and finishes available in range / Plus de matières premières et de finitions disponibles dans la gamme / Más materias primas y acabados disponibles en gama



Cobre / Cuivre / Cooper / Cobre

PCL 7338



CÓDIGO CODE / CODE / CÓDIGO	DIMENSÕES SIZE / DIMENSIONS MEDIDA	EMBALAGEM QUANTITY / EMBALLAGE / EMBALAJE
000091236404	6.35 x 16	500
000091276505	6.35 x 18.5	500
000091276504	6.35 x 21	500
000091236403	7.65 x 16	500
000091913601	7.65 x 18	500
000091236402	7.65 x 21	500
000091276503	8.35 x 16	250
000091276502	8.35 x 18	250
000091276501	8.35 x 21	250

Mais matérias primas e acabamentos disponíveis em gama / More raw materials and finishes available in range / Plus de matières premières et de finitions disponibles dans la gamme / Más materias primas y acabados disponibles en gama

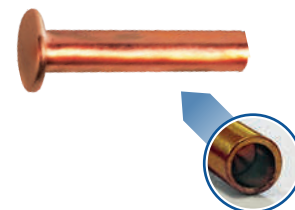

Cobre / Cuivre / Cooper / Cobre

PCL 7338



CÓDIGO CODE / CODE / CÓDIGO	DIMENSÕES SIZE / DIMENSIONS MEDIDA	EMBALAGEM QUANTITY / EMBALLAGE / EMBALAJE
733891635130	6.35 x 13	500
733891635160	6.35 x 16	500
733891631850	6.35 x 18.5	500
733891635210	6.35 x 21	500
733891765160	7.65 x 16	500
733891761850	7.65 x 18.5	500
733891765210	7.65 x 21	250
733891765250	7.65 x 25	250

Mais matérias primas e acabamentos disponíveis em gama / More raw materials and finishes available in range / Plus de matières premières et de finitions disponibles dans la gamme / Más materias primas y acabados disponibles en gama



**Cabeça de embeber**  
/ Countersunk head / Tête fraisée  
/ Cabeza avellanada



# REBITES

Blind rivets / Rivets / Remaches

## PCL 7339

### Rebite Semi Furado Cabeça Cilíndrica

Blind rivet nuts with cylindrical head / Rivet noyé à tête cylindrique / Remache semi agujereado con cabeza cilíndrica

PCL 7339

Ferro / Iron / Fer / Hierro

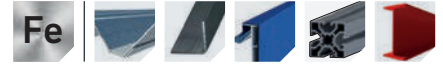

CÓDIGO CODE / CODE / CÓDIGO	DIMENSÕES SIZE / DIMENSIONS MEDIDA	EMBALAGEM QUANTITY / EMBALLAGE / EMBALAJE
733911080100	8 x 10	2500
733911080120	8 x 12	2500
733911080130	8 x 13	2500
733911080160	8 x 16	2000
733911080190	8 x 19	2000
733911080220	8 x 22	1500
733911080240	8 x 24	1000
733911080270	8 x 27	1000
733911080310	8 x 31	1000
733911080340	8 x 34	1000
733911080360	8 x 36	1000
733911080420	8 x 42	750
733911080440	8 x 44	750
733911080450	8 x 45	750
733911080480	8 x 48	750
733911080500	8 x 50	750
733911080530	8 x 53	500

Mais matérias primas e acabamentos disponíveis em gama / More raw materials and finishes available in range / Plus de matières premières et de finitions disponibles dans la gamme / Más materias primas y acabados disponibles en gama

PCL 7339

Zincado / Zinc plated / Zingué / Zincado

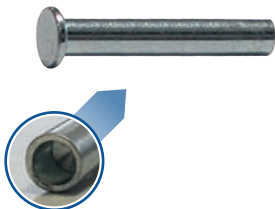
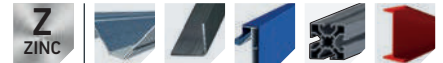

CÓDIGO CODE / CODE / CÓDIGO	DIMENSÕES SIZE / DIMENSIONS MEDIDA	EMBALAGEM QUANTITY / EMBALLAGE / EMBALAJE
733912080100	8 x 10	2500
733912080120	8 x 12	2500
733912080130	8 x 13	2500
733912080160	8 x 16	2000
733912080190	8 x 19	2000
733912080220	8 x 22	1500
733912080240	8 x 24	1000
733912080270	8 x 27	1000
733912080310	8 x 31	1000
733912080340	8 x 34	1000
733912080360	8 x 36	1000
733912080420	8 x 42	750
733912080440	8 x 44	750
733912080450	8 x 45	750
733912080480	8 x 48	750
733912080500	8 x 50	750
733912080530	8 x 53	500

Mais matérias primas e acabamentos disponíveis em gama / More raw materials and finishes available in range / Plus de matières premières et de finitions disponibles dans la gamme / Más materias primas y acabados disponibles en gama



## Porca de Rebitar Cabeça Reduzida

Steel threaded inserts reduced head / Inserts filetés en acier tête réduite / Tuerca remachable en acero cabeza reducida

# PCL 990

Acero / Acier / Steel / Aço

PCL 990



CÓDIGO CODE / CODE / CÓDIGO	DIMENSÕES SIZE / DIMENSIONS MEDIDA	ESPESSURA A FIXAR FIXTURE THICKNESS / ÉPAISSEUR À FIXER / ESPESOR A FIJAR	EMBALAGEM QUANTITY / EMBALLAGE / EMBALAJE
099022030000	FTT/R M3 x 8,5	0,5 - 1,5	1000
099022040000	FTT/R M4 x 10	0,5 - 2	1000
099022050000	FTT/R M5 x 12	0,5 - 3	500
099022060000	FTT/R M6 x 13,5	0,5 - 3	500
099022080000	FTT/R M8 x 16,5	0,5 - 3	500
099022100000	FTT/R M10 x 18	0,7 - 3,5	200
099022120000	FTT/R M12 x 21	1 - 3,5	100

Mais matérias primas e acabamentos disponíveis em gama / More raw materials and finishes available in range / Plus de matières premières et de finitions disponibles dans la gamme / Más materias primas y acabados disponibles en gama



Inoxidable A2 / Inoxydable A2 / Stainless steel A2 / Aço inox A2

PCL 990

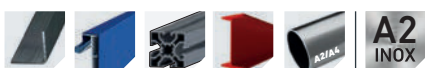

CÓDIGO CODE / CODE / CÓDIGO	DIMENSÕES SIZE / DIMENSIONS MEDIDA	ESPESSURA A FIXAR FIXTURE THICKNESS / ÉPAISSEUR À FIXER / ESPESOR A FIJAR	EMBALAGEM QUANTITY / EMBALLAGE / EMBALAJE
099061040000	FTT/R M4 x 10	0,5 - 2	200
099061050000	FTT/R M5 x 12	0,5 - 3	200
099061060000	FTT/R M6 x 13,5	0,5 - 3	200
099061080000	FTT/R M8 x 16,5	0,5 - 3	200
099061100000	FTT/R M10 x 18	0,7 - 3,5	200

Mais matérias primas e acabamentos disponíveis em gama / More raw materials and finishes available in range / Plus de matières premières et de finitions disponibles dans la gamme / Más materias primas y acabados disponibles en gama



## Porca de Rebitar Cabeça Cilíndrica

Steel threaded inserts cylindrical head / Inserts filetés en acier tête cylindrique / Tuerca remachable en acero cabeza ancha

# PCL 991

Acero / Acier / Steel / Aço

PCL 991



CÓDIGO CODE / CODE / CÓDIGO	DIMENSÕES SIZE / DIMENSIONS MEDIDA	ESPESSURA A FIXAR FIXTURE THICKNESS / ÉPAISSEUR À FIXER / ESPESOR A FIJAR	EMBALAGEM QUANTITY / EMBALLAGE / EMBALAJE
099122040000	FTT/C M4 x 11	0,3 - 2,5	500
099122040001	FTT/L M4 x 13	2,5 - 4	500
099122050000	FTT/C M5 x 13	0,5 - 3	500
099122050001	FTT/L M5 x 15,5	3 - 5	500
099122060000	FTT/C M6 x 14,5	0,5 - 2,3	500
099122060001	FTT/L M6 x 17,5	2,3 - 4	500
099122080000	FTT/C M8 x 17,5	0,8 - 3,5	500
099122080001	FTT/L M8 x 20	3,5 - 6	500
099122100000	FTT/C M10 x 21	1 - 3,5	200
099122100001	FTT/L M10 x 24	3,5 - 60	200
099122120000	FTT/C M12 x 22	1 - 3,5	100

Mais matérias primas e acabamentos disponíveis em gama / More raw materials and finishes available in range / Plus de matières premières et de finitions disponibles dans la gamme / Más materias primas y acabados disponibles en gama

Inoxidable A2 / Inoxydable A2 / Stainless steel A2 / Aço inox A2

PCL 991

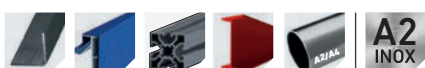

CÓDIGO CODE / CODE / CÓDIGO	DIMENSÕES SIZE / DIMENSIONS MEDIDA	ESPESSURA A FIXAR FIXTURE THICKNESS / ÉPAISSEUR À FIXER / ESPESOR A FIJAR	EMBALAGEM QUANTITY / EMBALLAGE / EMBALAJE
099161040000	FTT/C M4 x 11	0,3 - 2,5	200
099161050000	FTT/C M5 x 13	0,5 - 3	200
099161060000	FTT/C M6 x 14,5	0,5 - 2,3	200
099161080000	FTT/C M8 x 20	0,8 - 3,5	200

Mais matérias primas e acabamentos disponíveis em gama / More raw materials and finishes available in range / Plus de matières premières et de finitions disponibles dans la gamme / Más materias primas y acabados disponibles en gama





# REBITES

Blind rivets / Rivets / Remaches

## PCL 992

### Porca de Rebitar Sextavada

Steel threaded inserts cylindrical head hexagonal shank / Inserts filetés en acier tête cylindrique queue hexagonale / Tuerca remachable hexagonal en acero cabeza ancha

PCL 992

Aço / Steel / Acier / Acero

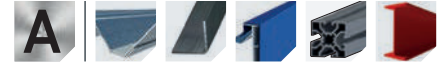

CÓDIGO CODE / CODE / CÓDIGO	DIMENSÕES SIZE / DIMENSIONS MEDIDA	ESPESSURA A FIXAR FIXTURE THICKNESS / ÉPAISSEUR À FIXER / ESPESOR A FIJAR	EMBALAGEM QUANTITY / EMBALLAGE / EMBALAJE
099222040000	FTT/E M4 x 11	0.5 - 2	500
099222050000	FTT/E M5 x 14	0.5 - 3	500
099222060000	FTT/E M6 x 16	0.5 - 3	500
099222080000	FTT/E M8 x 18	0.5 - 3	500
099222100000	FTT/E M10 x 20	0.5 - 3	500

Mais matérias primas e acabamentos disponíveis em gama / More raw materials and finishes available in range / Plus de matières premières et de finitions disponibles dans la gamme / Más materias primas y acabados disponibles en gama

PCL 992

Aço inox A2 / Stainless steel A2 /Inoxydable A2 / Inoxidable A2



CÓDIGO CODE / CODE / CÓDIGO	DIMENSÕES SIZE / DIMENSIONS MEDIDA	ESPESSURA A FIXAR FIXTURE THICKNESS / ÉPAISSEUR À FIXER / ESPESOR A FIJAR	EMBALAGEM QUANTITY / EMBALLAGE / EMBALAJE
099261050000	FTT/E M5 x 14	0.5 - 2	200
099261060000	FTT/E M6 x 16	0.5 - 3	200
099261080000	FTT/E M8 x 18	0.5 - 3	200
099261100000	FTT/E M10 x 20	0.5 - 3	200

Mais matérias primas e acabamentos disponíveis em gama / More raw materials and finishes available in range / Plus de matières premières et de finitions disponibles dans la gamme / Más materias primas y acabados disponibles en gama

## PCL 993

### Porca de Rebitar Sextavada Reduzida

Steel threaded inserts reduced head hexagonal shank / Inserts filetés en acier tête réduite queue hexagonale / Tuerca remachable hexagonal en acero cabeza reducida

PCL 993

Aço / Steel / Acier / Acero



CÓDIGO CODE / CODE / CÓDIGO	DIMENSÕES SIZE / DIMENSIONS MEDIDA	ESPESSURA A FIXAR FIXTURE THICKNESS / ÉPAISSEUR À FIXER / ESPESOR A FIJAR	EMBALAGEM QUANTITY / EMBALLAGE / EMBALAJE
099322040000	FTT/ER M4 x 11	0.5 - 2	500
099322050000	FTT/ER M5 x 14	0.5 - 3	500
099322060000	FTT/ER M6 x 16	0.5 - 3	500
099322080000	FTT/ER M8 x 18	0.5 - 3	500

Mais matérias primas e acabamentos disponíveis em gama / More raw materials and finishes available in range / Plus de matières premières et de finitions disponibles dans la gamme / Más materias primas y acabados disponibles en gama

PCL 993

Aço inox A2 / Stainless steel A2 /Inoxydable A2 / Inoxidable A2



CÓDIGO CODE / CODE / CÓDIGO	DIMENSÕES SIZE / DIMENSIONS MEDIDA	ESPESSURA A FIXAR FIXTURE THICKNESS / ÉPAISSEUR À FIXER / ESPESOR A FIJAR	EMBALAGEM QUANTITY / EMBALLAGE / EMBALAJE
099361040000	FTT/ER M4 x 11	0.5 - 2	200
099361050000	FTT/ER M5 x 14	0.5 - 3	200
099361060000	FTT/ER M6 x 16	0.5 - 3	200
099361080000	FTT/ER M8 x 18	0.5 - 3	200

Mais matérias primas e acabamentos disponíveis em gama / More raw materials and finishes available in range / Plus de matières premières et de finitions disponibles dans la gamme / Más materias primas y acabados disponibles en gama

# BUCHAS METÁLICAS

METAL ANCHORS  
CHEVILLES METÁLICAS  
ANCLAJES METÁLICOS





## BUCHAS METÁLICAS

Metal anchors / Chevilles métalliques / Anclajes Metálicos

# PCL 752

## Bucha de Impacto

Drop-in anchor / Cheville Impact / Taco de Golpe

A bucha de impacto possui uma rosca métrica interna recomendada para fixações médias em betão. Esta bucha tem um corpo cilíndrico, entalhada com 4 ranhuras e um cone de expansão interno pré-montado. Devido à sua forma cilíndrica e plana permite ser introduzida facilmente e de forma profunda no interior do material base.

A rápida expansão permite uma fixação segura de parafusos ou pernos roscados.

*Drop-in Anchor is metal anchor with an inner thread recommended for medium load fixings in concrete. This anchor has a cylindrical body, slotted with 4 ribs and by inner pre-assembled expansion cone. Thanks to its flat shape allows to be embedded and fixed deep inside the base material. The easy expansion allows fast and safe fixing of bolts or studs.*

*La Cheville Impact possède une filetage métrique interne recommandé pour fixations moyennes sur béton. Cette cheville à un corps cylindrique, avec 4 entailles et un cône d'expansion interne pré-monté. Sa forme cylindrique et plane lui permet d'être introduite facilement et en profondeur à l'intérieur du matériau de base. Sa rapide expansion permet une fixation sûre des vis ou des boulons filetés.*

*El Taco de Golpe posee una rosca métrica interna recomendada para fijaciones medias en hormigón. Este taco tiene un cuerpo cilíndrico, entallado con 4 ranuras y un cono de expansión interno premontado. Debido a su forma cilíndrica y plana permite ser introducido fácilmente y de forma profunda en el interior del material base. La rápida expansión permite una fijación segura de tornillos o pernos roscados.*

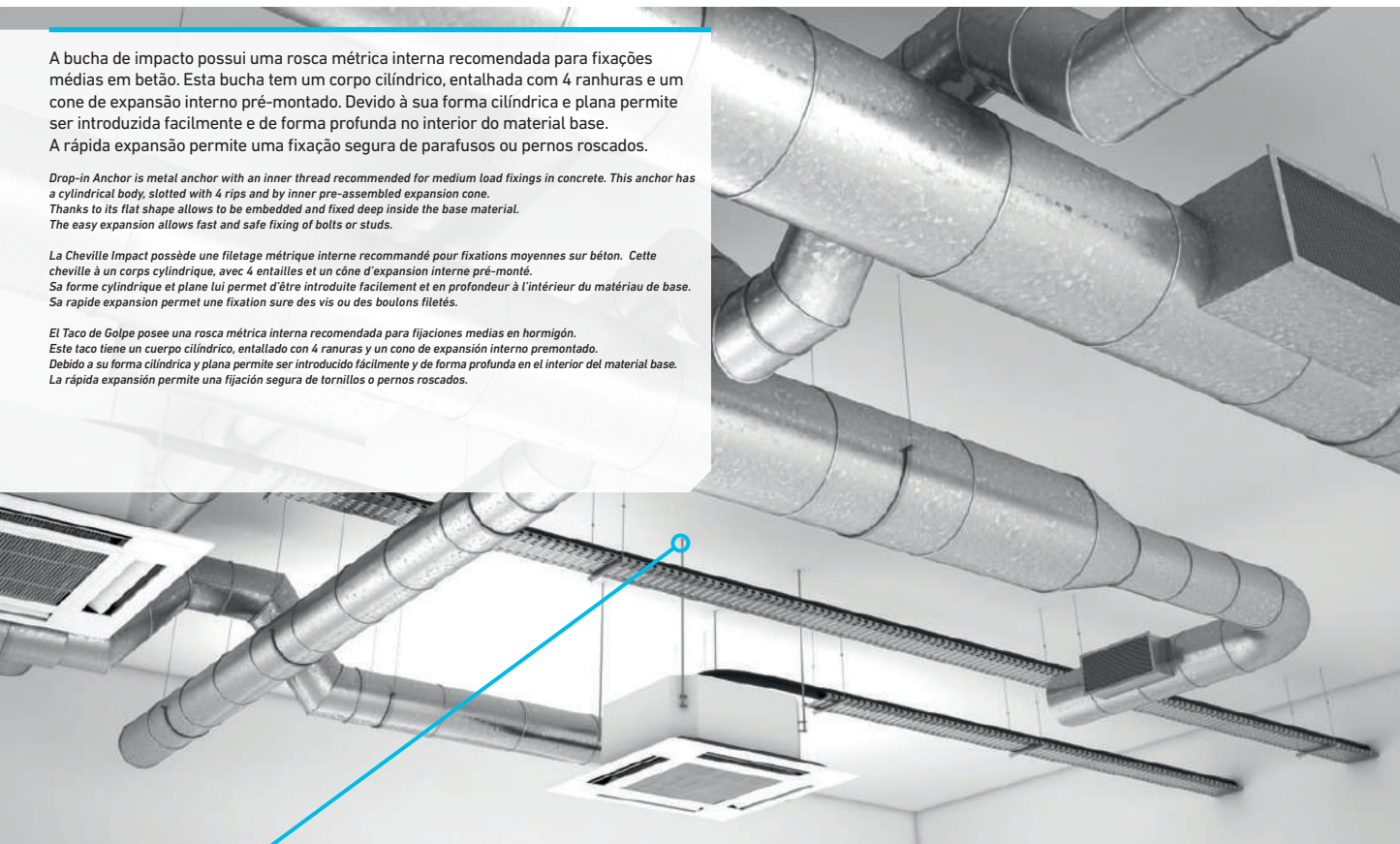

PCL 752 ZN



**Z**  
ZINC

PCL 752 A2



**A2**  
INOX





Zincado / Zingué / Zinc plated / Zincado

PCL 752



CÓDIGO CODE / CODE / CÓDIGO	DIMENSÕES SIZE / DIMENSIONS / MEDIDA	COMPRIMENTO LENGTH / LONGUEUR / LONGITUD	EMBALAGEM QUANTITY / EMBALLAGE / EMBALAJE
075223060000	M6 Ø8	25	100
075223080000	M8 Ø10	30	100
075223100000	M10 Ø12	40	50
075223120000	M12 Ø16	50	50
075223160000	M16 Ø20	65	25
075223200000	M20 Ø27	70	25



**Vigas | Sistema de ventilação | Sistema de aquecimento de teto | Lâmpadas | Conduitas | Sistemas de aspersores | Perfis metálicos**  
Beams | Ventilation system | Ceiling heating system | Ceiling lightning | Pipelines | Sprinklers systems | Metallic profiles  
Poutres | Systèmes de ventilation | Systèmes de chauffage plafond | Lampes | Conduits | Aspergeurs | Profilés métalliques  
Vigas | Sistema de ventilación | Sistema de calentamiento de techo | Lámparas | Conductos | Sistemas de aspersores | Perfiles metálicos

Inoxidável A2 / Inoxydable A2 / Stainless steel A2 / Aço inox A2

PCL 752



CÓDIGO CODE / CODE / CÓDIGO	DIMENSÕES SIZE / DIMENSIONS / MEDIDA	COMPRIMENTO LENGTH / LONGUEUR / LONGITUD	EMBALAGEM QUANTITY / EMBALLAGE / EMBALAJE
075261060000	M6 Ø8	25	100
075261080000	M8 Ø10	30	100
075261100000	M10 Ø12	40	50
075261120000	M12 Ø16	50	50
075261160000	M16 Ø20	65	25
075261200000	M20 Ø25	80	25



**Vigas | Sistema de ventilação | Sistema de aquecimento de teto | Lâmpadas | Conduitas | Sistemas de aspersores | Perfis metálicos**  
Beams | Ventilation system | Ceiling heating system | Ceiling lightning | Pipelines | Sprinklers systems | Metallic profiles  
Poutres | Systèmes de ventilation | Systèmes de chauffage plafond | Lampes | Conduits | Aspergeurs | Profilés métalliques  
Vigas | Sistema de ventilación | Sistema de calentamiento de techo | Lámparas | Conductos | Sistemas de aspersores | Perfiles metálicos





## BUCHAS METÁLICAS

Metal anchors / Chevilles métalliques / Anclajes Metálicos

# PCL 753

## Bucha Segmentada PCL 753

Wedge Anchor PCL 753 / Cheville PCL 753 / Taco PCL 753

A Bucha PCL 753, é produzida em aço. Esta bucha é composta por um perno roscado e um clip de expansão de três segmentos que permite uma fixação eficaz em materiais sólidos (betão, pedra natural). A porca pré-montada e a anilha DIN 125 permitem uma instalação rápida. O seu formato ajuda a expansão e evita a rotação da bucha ao apertar a porca.

*The Wedge Anchor PCL 753 is made of steel. This anchor is assembled with a three segment expansion clip and endowed with long threaded rod, allows fastening on stiff material (concrete, natural stone). The pre-assembled nut and the washer DIN 125 allows a fast installation and the shape of expansion clip avoid the rotation of the anchor while tightening the nut.*

*La Cheville PCL 753 est produite en acier. Cette Cheville est composée par un boulon fileté long et un clip d'expansion de trois segments qui permet une fixation efficace sur matériaux solides (béton, pierre naturelle). L'écrou pré-monté et la rondelle DIN 125 permettent une installation rapide. Son format aide à l'expansion et évite la rotation de la cheville au moment de serrer l'écrou.*

*El Taco PCL 753, está fabricado en acero. Este taco está compuesto por un perno roscado con un rango de longitudes muy amplio y un clip de expansión de tres segmentos que permite una fijación eficaz en materiales sólidos (hormigón, piedra natural). La tuerca premontada y la arandela DIN 125 permiten una instalación rápida. Su formato ayuda la expansión y a evitar la rotación del dispositivo de anclaje al apretar la tuerca.*

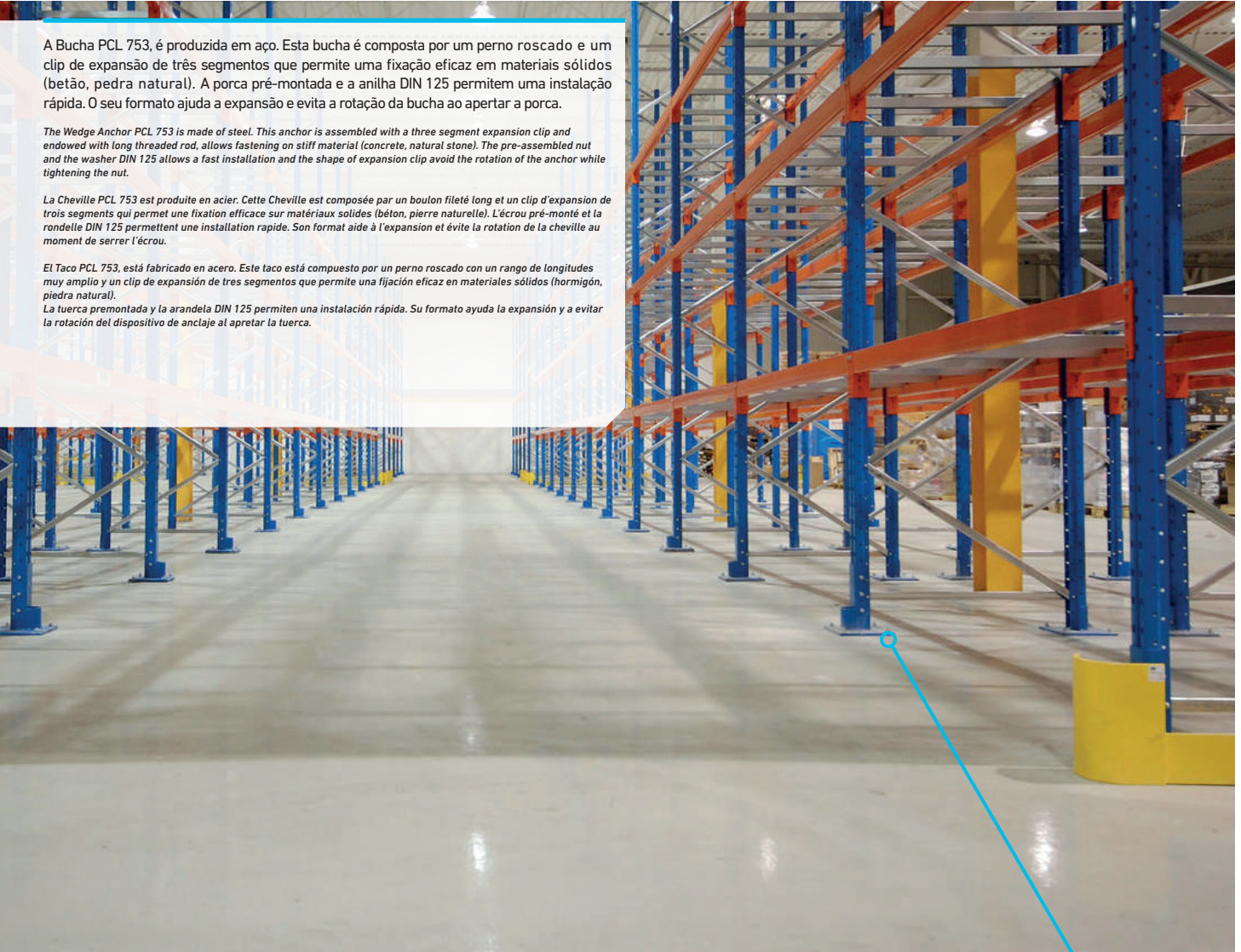

PCL 753 ETA ZN

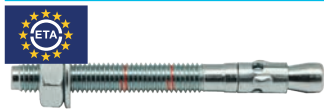

Z  
ZINC

PCL 753 ETA A4

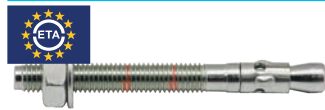

A4  
INOX

PCL 753 ZN



Z  
ZINC

PCL 753 A2



A2  
INOX

# PCL753

## Bucha Segmentada PCL 753

Wedge Anchor PCL 753 / Cheville PCL 753 / Taco PCL 753

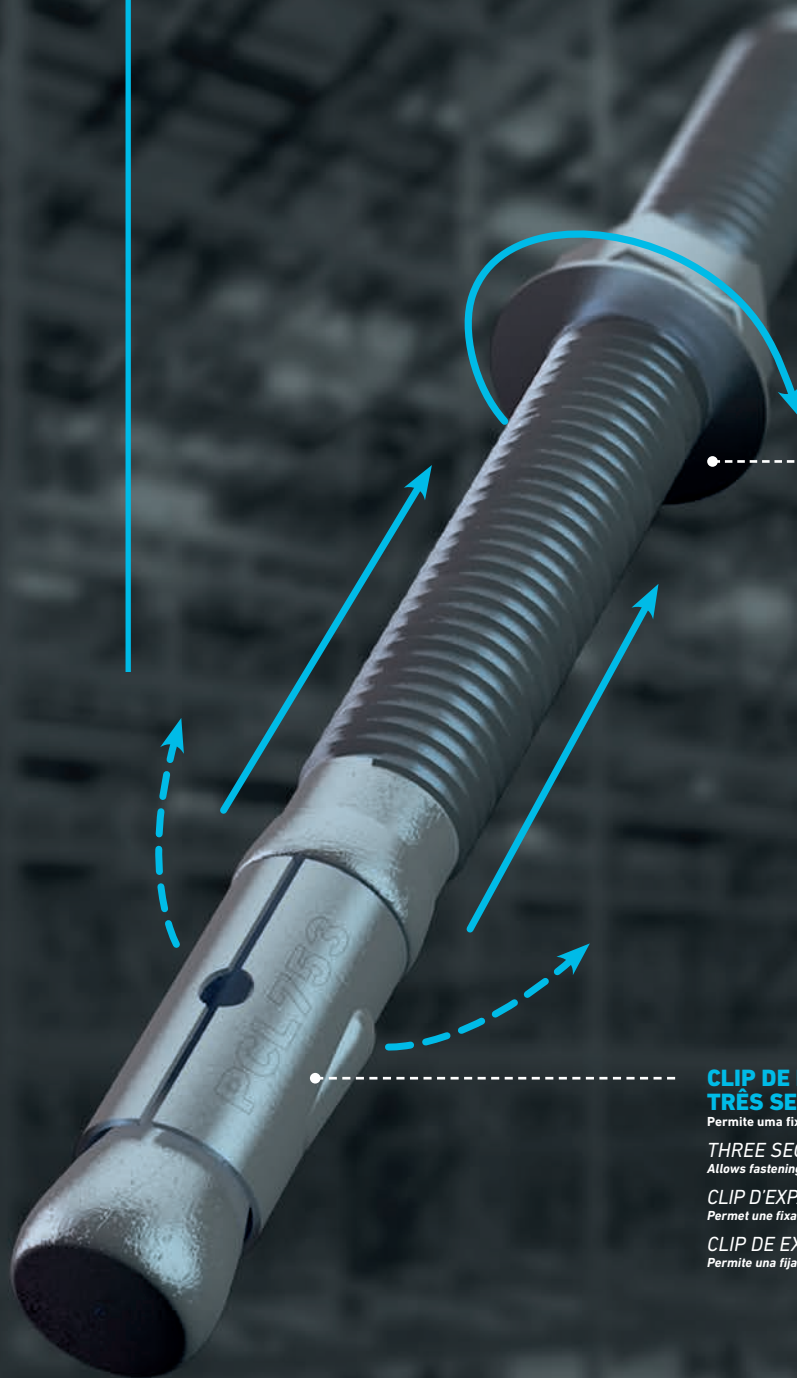

### PORCA PRÉ-MONTADA E ANILHA DIN 125

Permite uma instalação rápida

PRE-ASSEMBLED NUT AND WASHER DIN 125

Allows a fast installation

ÉCROU PRÉ-MONTÉ ET RONDELLE DIN 125

Permettent une installation rapide

TUERCA PREMONTADA Y ARANDELA DIN 125

Permiten una instalación rápida

### CLIP DE EXPANSÃO DE TRÊS SEGMENTOS

Permite uma fixação eficaz em materiais sólidos

THREE SEGMENT EXPANSION CLIP

Allows fastening on stiff material

CLIP D'EXPANSION DE TROIS SEGMENTS

Permet une fixation efficace sur matériaux solides

CLIP DE EXPANSIÓN DE TRES SEGMENTOS

Permite una fijación eficaz en materiales sólidos

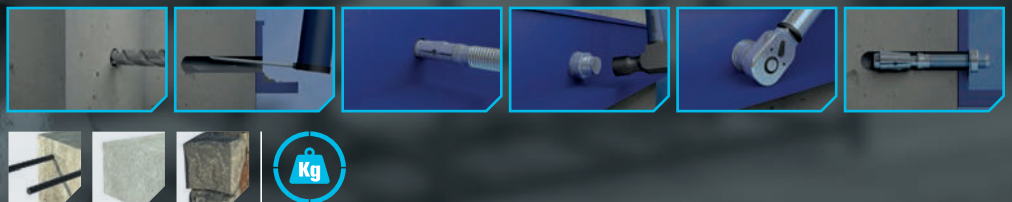



# BUCHAS METÁLICAS

Metal anchors / Chevilles métalliques / Anclajes Metálicos

PCL 753

Homologação ETA opção 7 / Option 7 ETA approved / Homologuée ATE Option 7 / Homologado ETA Opción 7

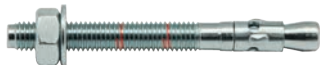

CÓDIGO CODE / CODE / CÓDIGO	DIMENSÕES SIZE / DIMENSIONS / MEDIDA	ESPESSURA MÁX. A FIXAR MAX. FIXTURE THICKNESS / ÉPAISSEUR MAX. À FIXER / ESPESOR MÁX. A FIJAR	EMBALAGEM QUANTITY / EMBALLAGE / EMBALAJE
075323060451	M6 x 45 Ø6	2	200
075323060601	M6 x 60 Ø6	2	200
075323060701	M6 x 70 Ø6	12	200
075323060801	M6 x 80 Ø6	22	200
075323060901	M6 x 90 Ø6	32	200
075323061001	M6 x 100 Ø6	42	200
075323061101	M6 x 110 Ø6	52	200
075323061201	M6 x 120 Ø6	62	100
075323080501	M8 x 50 Ø8	5	100
075323080601	M8 x 60 Ø8	3	100
075323080751	M8 x 75 Ø8	5	100
075323080901	M8 x 90 Ø8	30	100
075323081001	M8 x 100 Ø8	20	100
075323081151	M8 x 115 Ø8	45	100
075323081201	M8 x 120 Ø8	50	100
075323081301	M8 x 130 Ø8	60	100
075323081551	M8 x 155 Ø8	85	100
075323100701	M10 x 70 Ø10	5	100
075323100801	M10 x 80 Ø10	15	100
075323100901	M10 x 90 Ø10	10	100
075323101001	M10 x 100 Ø10	20	100
075323101201	M10 x 120 Ø10	40	50
075323101401	M10 x 140 Ø10	60	50
075323101501	M10 x 150 Ø10	70	50
075323101601	M10 x 160 Ø10	80	50
075323101701	M10 x 170 Ø10	90	50
075323102101	M10 x 210 Ø10	130	50
075323102301	M10 x 230 Ø10	150	50
075323120751	M12 x 75 Ø12	5	50
075323120901	M12 x 90 Ø12	13	50
075323121001	M12 x 100 Ø12	23	50
075323121101	M12 x 110 Ø12	18	50
075323121201	M12 x 120 Ø12	28	50
075323121301	M12 x 130 Ø12	38	50
075323121401	M12 x 140 Ø12	48	50
075323121601	M12 x 160 Ø12	68	50
075323121801	M12 x 180 Ø12	88	50
075323122001	M12 x 200 Ø12	108	50
075323122201	M12 x 220 Ø12	128	50
075323122501	M12 x 250 Ø12	158	25
075323140801	M14 x 80 Ø14	5	50
075323141001	M14 x 100 Ø14	5	50
075323141201	M14 x 120 Ø14	12	25
075323141451	M14 x 145 Ø14	37	25
075323141701	M14 x 170 Ø14	62	25
075323142201	M14 x 220 Ø14	112	25
075323142501	M14 x 250 Ø14	142	25
075323160901	M16 x 90 Ø16	5	25
075323161251	M16 x 125 Ø16	5	25
075323161451	M16 x 145 Ø16	25	25
075323161701	M16 x 170 Ø16	48	25
075323162201	M16 x 220 Ø16	98	25
075323162501	M16 x 250 Ø16	128	25
075323162801	M16 x 280 Ø16	158	25
075323201201	M20 x 120 Ø20	5	20
075323201701	M20 x 170 Ø20	23	20
075323202201	M20 x 220 Ø20	73	20
075323202701	M20 x 270 Ø20	123	20
075323241801	M24 x 180 Ø24	4	10
075323242601	M24 x 260 Ø24	84	10



Obras estruturais pesadas | Corrimões e balaústres | Portões | Mobiliário urbano | Gradeamentos de varandas  
 Heavy structure works | Railing and balustrades | Gates | Urban Furniture | Balcony handrails  
 Travaux structurels lourds | Rampes et balustrades | Portails | Mobiliers urbain | Grillages de vérandas  
 Obras estructurales pesadas | Pasamanos y balaustradas | Portones | Mobiliario urbano | Barandillas de terrazas



CÓDIGO CODE / CODE / CÓDIGO	DIMENSÕES SIZE / DIMENSIONS / MEDIDA	ESPESSURA MÁX. A FIXAR MAX. FIXTURE THICKNESS / ÉPAISSEUR MAX. À FIXER / ESPESOR MÁX. A FIJAR	EMBALAGEM QUANTITY / EMBALLAGE / EMBALAJE
075371060451	M6 x 45 Ø6	2	200
075371060601	M6 x 60 Ø6	2	200
075371060801	M6 x 80 Ø6	22	200
075371080501	M8 x 50 Ø8	5	100
075371080751	M8 x 75 Ø8	5	100
075371080901	M8 x 90 Ø8	20	100
075371081151	M8 x 115 Ø8	45	100
075371100701	M10 x 70 Ø10	5	100
075371100901	M10 x 90 Ø10	10	100
075371101201	M10 x 120 Ø10	40	50
075371101501	M10 x 150 Ø10	70	50
075371120751	M12 x 75 Ø12	5	50
075371120901	M12 x 90 Ø12	13	50
075371121101	M12 x 110 Ø12	18	50
075371121401	M12 x 140 Ø12	48	50
075371160901	M16 x 90 Ø16	5	25
075371161451	M16 x 145 Ø16	25	25
075371161701	M16 x 170 Ø16	48	25
075371201201	M20 x 120 Ø20	5	20
075371201701	M20 x 170 Ø20	23	20
075371202201	M20 x 220 Ø20	73	20

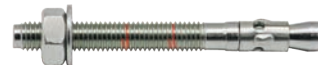

**Obras estruturais pesadas | Corrimões e balaústres | Portões | Mobiliário urbano | Gradeamentos de varandas**  
*Heavy structure works | Railing and balustrades | Gates | Urban Furniture | Balcony handrails*  
*Travaux structurels lourds | Rampes et balustrades | Portails | Mobiliers urbain | Grillages de vérandas*  
*Obras estructurales pesadas | Pasamanos y balastradas | Portones | Mobiliario urbano | Barandillas de terrazas*

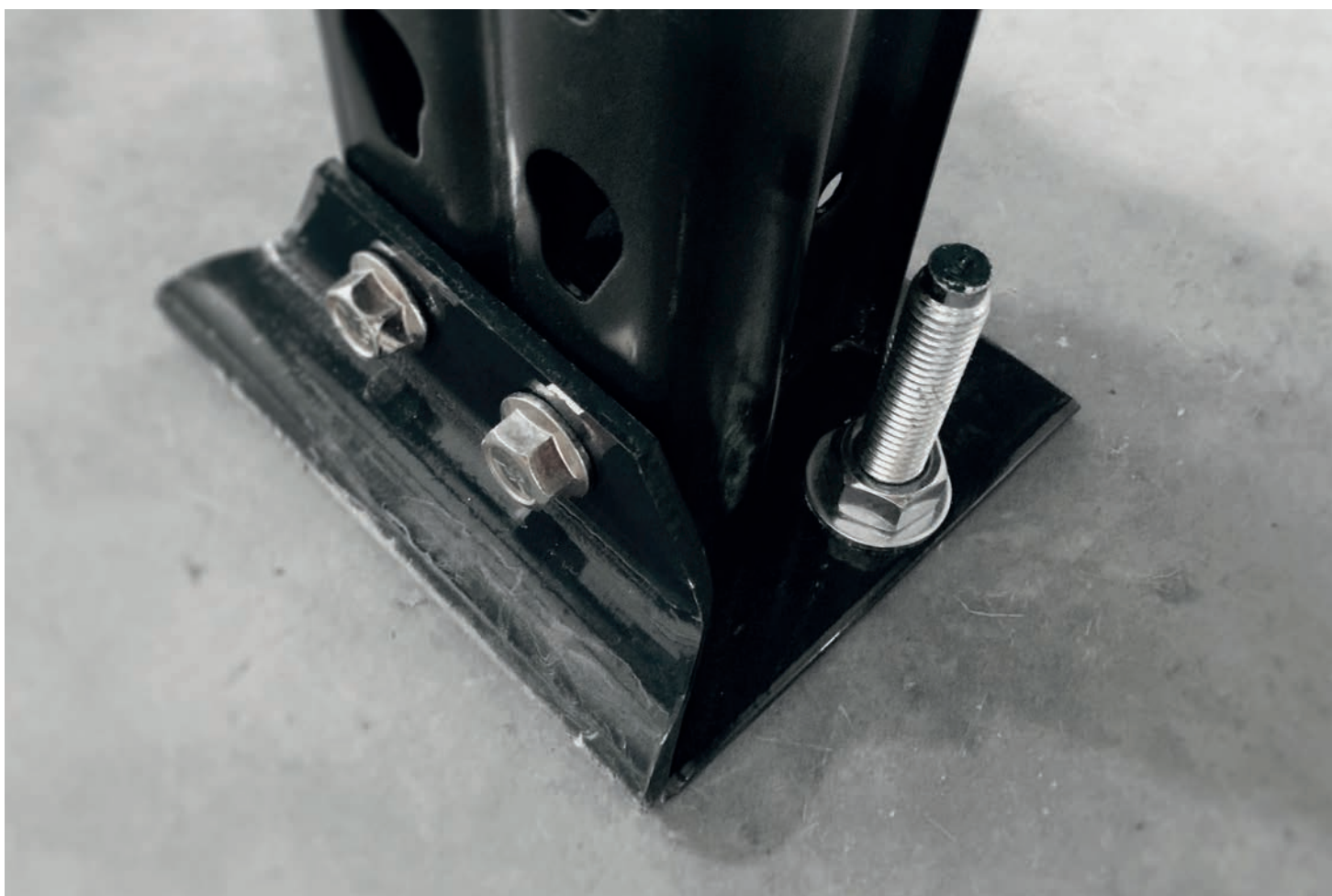



# BUCHAS METÁLICAS

Metal anchors / Chevilles métalliques / Anclajes Metálicos

PCL 753

Zincado / Zinc plated / Zingué / Zincado



CÓDIGO CODE / CODE / CÓDIGO	DIMENSÕES SIZE / DIMENSIONS / MEDIDA	ESPESSURA MÁX. A FIXAR MAX. FIXTURE THICKNESS / ÉPAISSEUR MAX. À FIXER / ESPESOR MÁX. A FIJAR	EMBALAGEM QUANTITY / EMBALLAGE / EMBALAJE
075323060400	M6 x 40 Ø6	2	250
075323060450	M6 x 45 Ø6	2	200
075323060550	M6 x 55 Ø6	12	200
075323060600	M6 x 60 Ø6	2	200
075323060650	M6 x 65 Ø6	7	200
075323060700	M6 x 70 Ø6	12	200
075323060800	M6 x 80 Ø6	22	200
075323060850	M6 x 85 Ø6	27	200
075323060900	M6 x 90 Ø6	32	200
075323061000	M6 x 100 Ø6	42	100
075323061100	M6 x 110 Ø6	52	100
075323061200	M6 x 120 Ø6	62	50
075323061300	M6 x 130 Ø6	72	50
075323061400	M6 x 140 Ø6	82	50
075323061500	M6 x 150 Ø6	92	50
75323061600	M6 x 160 Ø6	102	50
075323061700	M6 x 170 Ø6	112	25
075323061800	M6 x 180 Ø6	122	25
075323080500	M8 x 50 Ø8	5	100
075323080600	M8 x 60 Ø8	3	100
075323080650	M8 x 65 Ø8	8	100
075323080750	M8 x 75 Ø8	5	100
075323080900	M8 x 90 Ø8	20	100
075323080950	M8 x 95 Ø8	25	100
075323081150	M8 x 115 Ø8	45	100
075323081200	M8 x 120 Ø8	50	50
075323081300	M8 x 130 Ø8	60	50
075323081350	M8 x 135 Ø8	65	50
075323081550	M8 x 155 Ø8	85	50
075323100600	M10 x 60 Ø10	3	100
075323100650	M10 x 65 Ø10	8	100
075323100700	M10 x 70 Ø10	5	100
075323100800	M10 x 80 Ø10	15	100
075323100900	M10 x 90 Ø10	10	50
075323101000	M10 x 100 Ø10	20	50
075323101200	M10 x 120 Ø10	40	50
075323101400	M10 x 140 Ø10	60	50
075323101500	M10 x 150 Ø10	70	50
075323101600	M10 x 160 Ø10	80	50
075323101700	M10 x 170 Ø10	90	25
075323102100	M10 x 210 Ø10	130	25
075323102300	M10 x 230 Ø10	150	25
075323120700	M12 x 70 Ø12	5	50
075323120800	M12 x 80 Ø12	10	50
075323120900	M12 x 90 Ø12	13	25
075323120950	M12 x 95 Ø12	18	25
075323121000	M12 x 100 Ø12	23	25
075323121100	M12 x 110 Ø12	18	25
075323121200	M12 x 120 Ø12	28	25
075323121300	M12 x 130 Ø12	38	25
075323121400	M12 x 140 Ø12	48	25
075323121600	M12 x 160 Ø12	68	25
075323121800	M12 x 180 Ø12	88	25
075323122200	M12 x 220 Ø12	128	25
075323122400	M12 x 240 Ø12	148	25
075323122500	M12 x 250 Ø12	158	25
075322140800	M14 x 80 Ø14	5	50
075323141000	M14 x 100 Ø14	5	25
075323141200	M14 x 120 Ø14	12	25
075323141450	M14 x 145 Ø14	37	25
075323141700	M14 x 170 Ø14	62	25
075323142200	M14 x 220 Ø14	112	25
075323142500	M14 x 250 Ø14	142	20



CÓDIGO CODE / CODE / CÓDIGO	DIMENSÕES SIZE / DIMENSIONS / MEDIDA	ESPESSURA MÁX. A FIXAR MAX. FIXTURE THICKNESS / ÉPAISSEUR MAX. À FIXER / ESPESOR MÁX. A FIJAR	EMBALAGEM QUANTITY / EMBALLAGE / EMBALAJE
075323160900	M16 x 90 Ø16	5	25
075323161100	M16 x 110 Ø16	25	25
075323161250	M16 x 125 Ø16	5	25
075323161450	M16 x 145 Ø16	25	25
075323161700	M16 x 170 Ø16	48	25
075323161800	M16 x 180 Ø16	58	25
075323162200	M16 x 220 Ø16	98	10
075323162400	M16 x 240 Ø16	118	10
075323162500	M16 x 250 Ø16	128	10
075323162800	M16 x 280 Ø16	158	10
075323201200	M20 x 120 Ø20	5	15
075323201600	M20 x 160 Ø20	13	15
075323201700	M20 x 170 Ø20	23	10
075323201800	M20 x 180 Ø20	33	10
075323202200	M20 x 220 Ø20	73	10
075323202700	M20 x 270 Ø20	123	10
075323241600	M24 x 160 Ø24	10	10
075323241700	M24 x 170 Ø24	10	10
075323242200	M24 x 220 Ø24	50	10
075323242700	M24 x 270 Ø24	100	10



**Obras estruturais pesadas | Corrimões e balaústres | Portões | Mobiliário urbano | Gradeamentos de varandas**

Heavy structure works | Railing and balustrades | Gates | Urban Furniture | Balcony handrails

Travaux structurels lourds | Rampes et balustrades | Portails | Mobiliers urbain | Grilles de vérandas

Obras estructurales pesadas | Pasamanos y balastradas | Portones | Mobiliario urbano | Barandillas de terrazas

Inoxidable A2 / Inoxydable A2 / Stainless steel A2 / Aço inox A2

PCL 753



CÓDIGO CODE / CODE / CÓDIGO	DIMENSÕES SIZE / DIMENSIONS / MEDIDA	ESPESSURA MÁX. A FIXAR MAX. FIXTURE THICKNESS / ÉPAISSEUR MAX. À FIXER / ESPESOR MÁX. A FIJAR	EMBALAGEM QUANTITY / EMBALLAGE / EMBALAJE
075361060400	M6 x 40 Ø6	2	200
075361060550	M6 x 55 Ø6	12	100
075361060950	M6 x 95 Ø6	37	100
075361080500	M8 x 50 Ø8	5	100
075361080600	M8 x 60 Ø8	3	50
075361080750	M8 x 75 Ø8	5	50
075361080950	M8 x 95 Ø8	25	50
075361100800	M10 x 80 Ø10	15	50
075361100900	M10 x 90 Ø10	10	25
075361101200	M10 x 120 Ø10	40	25
075361120800	M12 x 80 Ø12	10	25
075361120900	M12 x 90 Ø12	13	25
075361121100	M12 x 110 Ø12	18	25
075361121350	M12 x 135 Ø12	43	25
075361161250	M16 x 125 Ø16	5	10
075361161450	M16 x 145 Ø16	25	10
075361161800	M16 x 180 Ø16	58	10
075361201600	M20 x 160 Ø20	13	10



**Obras estruturais pesadas | Corrimões e balaústres | Portões | Mobiliário urbano | Gradeamentos de varandas**

Heavy structure works | Railing and balustrades | Gates | Urban Furniture | Balcony handrails

Travaux structurels lourds | Rampes et balustrades | Portails | Mobiliers urbain | Grilles de vérandas

Obras estructurales pesadas | Pasamanos y balastradas | Portones | Mobiliario urbano | Barandillas de terrazas



# BUCHAS METÁLICAS

Metal anchors / Chevilles métalliques / Anclajes Metálicos

## PCL 764

### Bucha PCL 764

Sleeve Anchor PCL 764 / Cheville PCL 764 / Taco PCL 764

A bucha PCL 764 em aço zincado e Inox A2, permite uma montagem fácil e rápida na maioria dos substratos sólidos e ocos utilizados na construção civil. Recomendada para tijolo. O formato especial da bucha permite uma expansão rápida e as ranhuras junto à extremidade da bucha garantem uma melhor capacidade de agarre dentro do furo. O Anel interior em poliamida evita a rotação da bucha durante o aperto.

The sleeve anchor PCL 764 in galvanized steel and stainless steel A2, allows a quick and easy mounting in most of solid and hollow substrates used in construction. Recommended for Concrete. The special shape of the sleeve anchor allows a quick expansion and the dimples located on the bottom of the sleeve guarantee better grip with the hole inner surface. The expander, externally, avoids rotation during tightening.

La Cheville PCL 764 en acier zingué et Inox A2 permettent un montage facile et rapide sur la plupart des supports solides et creux utilisés dans la construction civile. Recommandé pour le béton. Le format spécial de la cheville permet une expansion rapide et les rainures près de l'extrémité de la cheville garantissent une meilleure capacité d'attache dans le trou. La Bague intérieure en polyamide évite la rotation de la cheville pendant le serrage.

El taco PCL 764 en acero suave, zincado y el taco en Inox A2, permite un montaje fácil y rápido en la mayoría de los substratos sólidos y huecos utilizados en la construcción civil. Recomendada para hormigón. El formato especial del taco permite una expansión rápida y su diseño antigiro garantiza una mejor capacidad de agarre dentro del agujero. El anillo interior de poliamida evita la rotación del taco durante el aprieto.



PCL 764 6.8 ZN



6.8

Z  
ZINC

PCL 764 8.8 ZN



8.8

Z  
ZINC

PCL 764 A2



A2  
INOX

PCL 764 10.9 ZN



10.9

Z  
ZINC

PCL 764 ZN+A2



Z  
ZINC + A2  
INOX

PCL 764 A2



A2  
INOX

PCL 764 CAM ZN



Z  
ZINC

PCL 764 PIT ZN



Z  
ZINC





Tornillo hexagonal 6.8 / Vis tête hexagonable 6.8 / Hexagon head screw 6.8 / Parafuso sextavado 6.8

PCL 764



CÓDIGO CODE / CODE / CÓDIGO	DIMENSÕES SIZE / DIMENSIONS / MEDIDA	EMBALAGEM QUANTITY / EMBALLAGE / EMBALAJE
076423060450	M6 x 45 Ø8	200
076423060600	M6 x 60 Ø8	100
076423080600	M8 x 60 Ø10	50
076423080800	M8 x 80 Ø10	50
076423100700	M10 x 70 Ø12	50
076423101000	M10 x 100 Ø12	25
076423101100	M10 x 110 Ø12	25
076423120800	M12 x 80 Ø16	25
076423121100	M12 x 110 Ø16	20
076423121300	M12 x 130 Ø16	10
076423161000	M16 x 100 Ø20	10
076423201300	M20 x 130 Ø25	10



**Gradeamentos | Portões | Toldos | Grades de proteção | Corrimões de varandas | Escadas**  
Railings | Gates | Awning | Guardrails | Balcony Handrails | Stairs  
Grillages | Portails | Bâches | Grilles de protection | Rampes de vérandas | Escaliers  
Enrejados | Portones | Toldos | Rejas de protección | Pasamanos de terrazas | Escaleras

Tornillo hexagonal 8.8 / Vis tête hexagonable 8.8 / Hexagon head screw 8.8 / Parafuso sextavado 8.8

PCL 764



CÓDIGO CODE / CODE / CÓDIGO	DIMENSÕES SIZE / DIMENSIONS / MEDIDA	EMBALAGEM QUANTITY / EMBALLAGE / EMBALAJE
076422060452	M6 x 45 Ø8	200
076422060602	M6 x 60 Ø8	200
076422080602	M8 x 60 Ø10	100
076422080802	M8 x 80 Ø10	100
076422100702	M10 x 70 Ø12	100
076422101002	M10 x 100 Ø12	50
076422120802	M12 x 80 Ø16	50
076422121102	M12 x 110 Ø16	50
076422161102	M16 x 110 Ø20	25



**Gradeamentos | Portões | Toldos | Grades de proteção | Corrimões de varandas | Escadas**  
Railings | Gates | Awning | Guardrails | Balcony Handrails | Stairs  
Grillages | Portails | Bâches | Grilles de protection | Rampes de vérandas | Escaliers  
Enrejados | Portones | Toldos | Rejas de protección | Pasamanos de terrazas | Escaleras

Inoxidable A2 / Inoxydable A2 / Stainless steel A2 / Aço inox A2

PCL 764



CÓDIGO CODE / CODE / CÓDIGO	DIMENSÕES SIZE / DIMENSIONS / MEDIDA	EMBALAGEM QUANTITY / EMBALLAGE / EMBALAJE
076461060451	M6 x 45 Ø8	100
076461060601	M6 x 60 Ø8	100
076461080601	M8 x 60 Ø10	100
076461080801	M8 x 80 Ø10	100
076461100700	M10 x 70 Ø12	100
076461101000	M10 x 100 Ø12	50
076461120800	M12 x 80 Ø16	50
076461121100	M12 x 110 Ø16	50
076461161100	M16 x 110 Ø20	25



**Gradeamentos | Portões | Toldos | Grades de proteção | Corrimões de varandas | Escadas**  
Railings | Gates | Awning | Guardrails | Balcony Handrails | Stairs  
Grillages | Portails | Bâches | Grilles de protection | Rampes de vérandas | Escaliers  
Enrejados | Portones | Toldos | Rejas de protección | Pasamanos de terrazas | Escaleras



# BUCHAS METÁLICAS

Metal anchors / Chevilles métalliques / Anclajes Metálicos

PCL 764

DIN 7991 10.9



CÓDIGO CODE / CODE / CÓDIGO	DIMENSÕES SIZE / DIMENSIONS / MEDIDA	EMBALAGEM QUANTITY / EMBALLAGE / EMBALAJE
076422060451	M6 x 45 Ø8	100
076422060601	M6 x 60 Ø8	100
076422080601	M8 x 60 Ø10	100
076422080801	M8 x 80 Ø10	100
076422100701	M10 x 70 Ø12	50
076422101001	M10 x 100 Ø12	50



Gradeamentos | Portões | Toldos | Grades de proteção | Corrimões de varandas | Escadas

Railings | Gates | Awning | Guardrails | Balcony Handrails | Stairs  
Grillages | Portails | Bâches | Grilles de protection | Rampes de vérandas | Escaliers  
Enrejados | Portones | Toldos | Rejas de protección | Pasamanos de terrazas | Escaleras

PCL 764

Zincado + DIN 7991 inox A2 / Zinc plated + Stainless steel A2 DIN 7991 / Zingué + DIN 7991 inoxydable A2 / Zincado + DIN 7991 inoxydable A2



CÓDIGO CODE / CODE / CÓDIGO	DIMENSÕES SIZE / DIMENSIONS / MEDIDA	EMBALAGEM QUANTITY / EMBALLAGE / EMBALAJE
076461060450	M6 x 45 Ø8	100
076461060600	M6 x 60 Ø8	100
076461080600	M8 x 60 Ø10	50
076461080800	M8 x 80 Ø10	50



Gradeamentos | Portões | Toldos | Grades de proteção | Corrimões de varandas | Escadas

Railings | Gates | Awning | Guardrails | Balcony Handrails | Stairs  
Grillages | Portails | Bâches | Grilles de protection | Rampes de vérandas | Escaliers  
Enrejados | Portones | Toldos | Rejas de protección | Pasamanos de terrazas | Escaleras

PCL 764

Inox + DIN 7991 inox A2 / Stainless Steel + Stainless steel A2 DIN 7991 / Inoxydable + DIN 7991 inoxydable A2 / Inoxidable + DIN 7991 inoxidable A2



CÓDIGO CODE / CODE / CÓDIGO	DIMENSÕES SIZE / DIMENSIONS / MEDIDA	EMBALAGEM QUANTITY / EMBALLAGE / EMBALAJE
076462060450	M6 x 45 Ø8	100
076462060600	M6 x 60 Ø8	100
076462080600	M8 x 60 Ø10	50
076462080800	M8 x 80 Ø10	50
076462100700	M10 x 70 Ø12	50



Gradeamentos | Portões | Toldos | Grades de proteção | Corrimões de varandas | Escadas

Railings | Gates | Awning | Guardrails | Balcony Handrails | Stairs  
Grillages | Portails | Bâches | Grilles de protection | Rampes de vérandas | Escaliers  
Enrejados | Portones | Toldos | Rejas de protección | Pasamanos de terrazas | Escaleras

PCL 764

Camarão / Hook bolt / Crochet / Gancho



CÓDIGO CODE / CODE / CÓDIGO	DIMENSÕES SIZE / DIMENSIONS / MEDIDA	ABERTURA GANCHO APERTURE HOOK / OUVERTURE CROCHET / APERTURA GANCHO	EMBALAGEM QUANTITY / EMBALLAGE / EMBALAJE
076423060452	M6 x 45 Ø8	10	100
076423080602	M8 x 60 Ø10	11	50
076423100702	M10 x 70 Ø16	22	25



Gradeamentos | Portões | Toldos | Grades de proteção | Corrimões de varandas | Escadas

Railings | Gates | Awning | Guardrails | Balcony Handrails | Stairs  
Grillages | Portails | Bâches | Grilles de protection | Rampes de vérandas | Escaliers  
Enrejados | Portones | Toldos | Rejas de protección | Pasamanos de terrazas | Escaleras



Argolla / Piton / Eye bolt / Pitão

PCL 764



CÓDIGO CODE / CODE / CÓDIGO	DIMENSÕES SIZE / DIMENSIONS / MEDIDA	Ø PITÃO EYE BOLT Ø / Ø OEIL / Ø OJO	EMBALAGEM QUANTITY / EMBALLAGE / EMBALAJE
076423060451	M6 x 45 Ø8	10	100
076423080601	M8 x 60 Ø10	11	50
076423100701	M10 x 70 Ø12	13.5	25



**Gradeamentos | Portões | Toldos | Grades de proteção | Corrimões de varandas | Escadas**  
Railings | Gates | Awning | Guardrails | Balcony Handrails | Stairs  
Grillages | Portails | Bâches | Grilles de protection | Rampes de vérandas | Escaliers  
Enrejados | Portones | Toldos | Rejas de protección | Pasamanos de terrazas | Escaleras

## Bucha Expansão PFG<sup>®</sup> PCL 782

Bucha Expansão PFG<sup>®</sup> PCL 782 / Cheville à Expansion PFG<sup>®</sup> PCL 782 / Taco Expansión PFG<sup>®</sup>

# PCL 782



CÓDIGO CODE / CODE / CÓDIGO	DIMENSÕES SIZE / DIMENSIONS / MEDIDA	COMPRIMENTO CÁPSULA SHILD LENGTH / LONGUEUR DOUILLE / LONGITUD CÁPSULA	EMBALAGEM QUANTITY / EMBALLAGE / EMBALAJE
078223060000	M6 x 40 Ø10	40	50
078223080000	M8 x 50 Ø14	50	50
078223100000	M10 x 60 Ø16	60	50
078223120000	M12 x 80 Ø20	80	25
078223160000	M16 x 105 Ø20	105	10



**Estruturas pesadas | Fixação de maquinaria | Balaústres | Portões | Gradeamentos | Perfis | Fachadas**  
Heavy structural works | Machinery | Balustrades | Gates | Railings | Profiles | Building facades  
Structures lourdes | Fixation de machinerie | Balustrades | Portails | Grillages | Profils | Façades  
Estructuras pesadas | Fijación de maquinaria | Balaustres | Portones | Enrejados | Perfiles | Fachadas

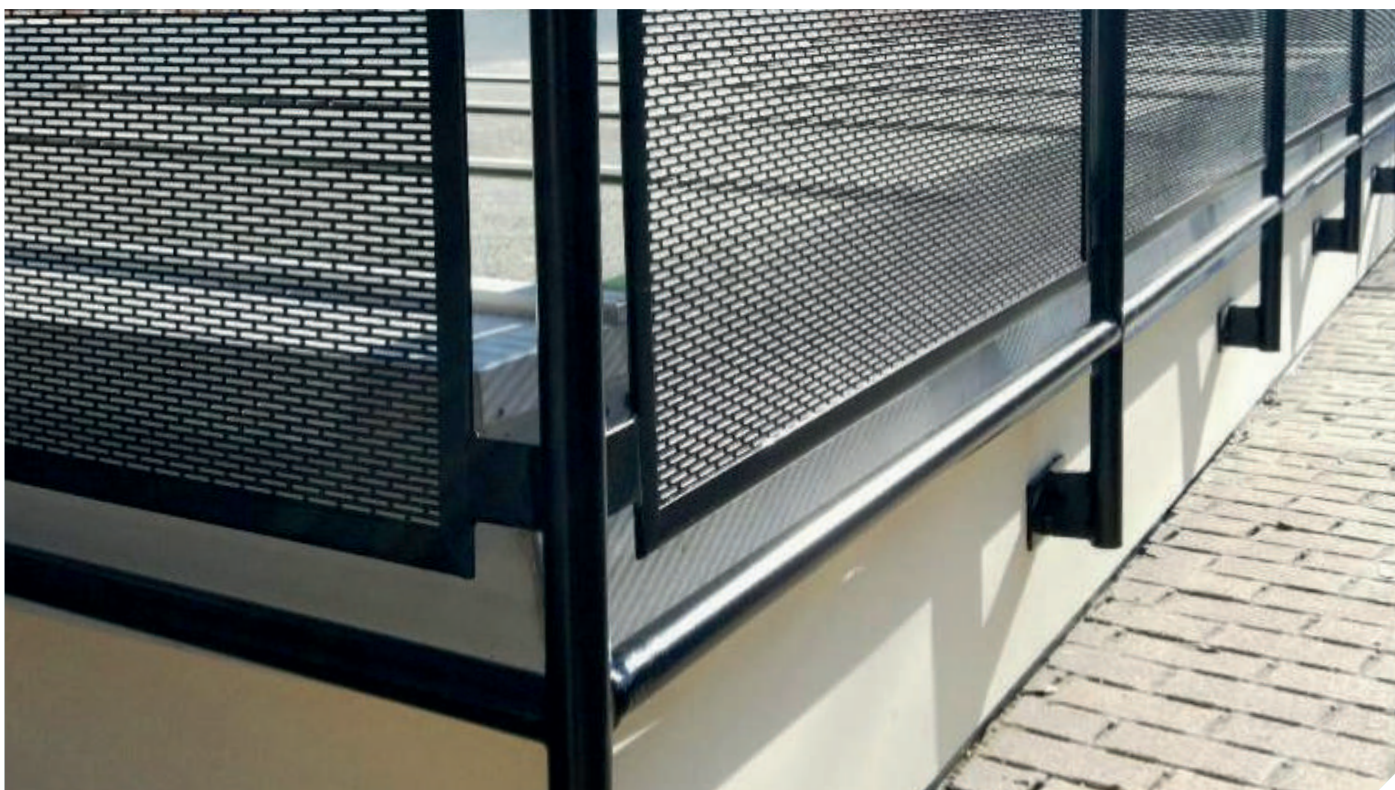



# BUCHAS METÁLICAS

Metal anchors / Chevilles métalliques / Anclajes Metálicos

## PCL 783

### Bucha de Expansão em Zamak PCL 783

Zamak Expansion Anchor PCL 783 / Cheville à Expansion Zamak PCL 783 / Taco de Expansión en Zamak PCL 783

A bucha de expansão em Zamak (zinco e alumínio) é recomendada para fixações de cargas médias e leves. Ideal para aplicações de cargas estáticas em materiais sólidos. Esta bucha é composta por uma porca interna pré-montada e quatro segmentos que asseguram uma fixação eficiente em todo o tipo de furos, mesmo em furos sobredimensionados.

The four shild expansion anchor made of Zamak (zinc, aluminium), is recommended for medium-light load fixings. Ideal for static applications on stiff materials. This anchor has an expansion nut pre-assembled internally and four segments which assure that the anchor fits into precise holes and on oversized drilled holes.

La Cheville à Expansion en Zamak (zinc et aluminium) est recommandée pour les fixations de charges moyennes et légères. Idéale pour applications de charges statiques sur matériaux solides. La cheville a un écrou d'expansion interne pré-monté et quatre segments qui assurent une fixation efficace sur tous types de trous, même les trous dimensionnés.

El Taco de Expansión en Zamak (zinc y aluminio) está recomendado para fijaciones de cargas medias y leves. Ideal para aplicaciones de cargas estáticas en materiales sólidos. Este taco está compuesto por una tuerca interna premontada y cuatro segmentos que aseguran una fijación eficiente en todo tipo de agujeros, incluso en agujeros sobredimensionados.

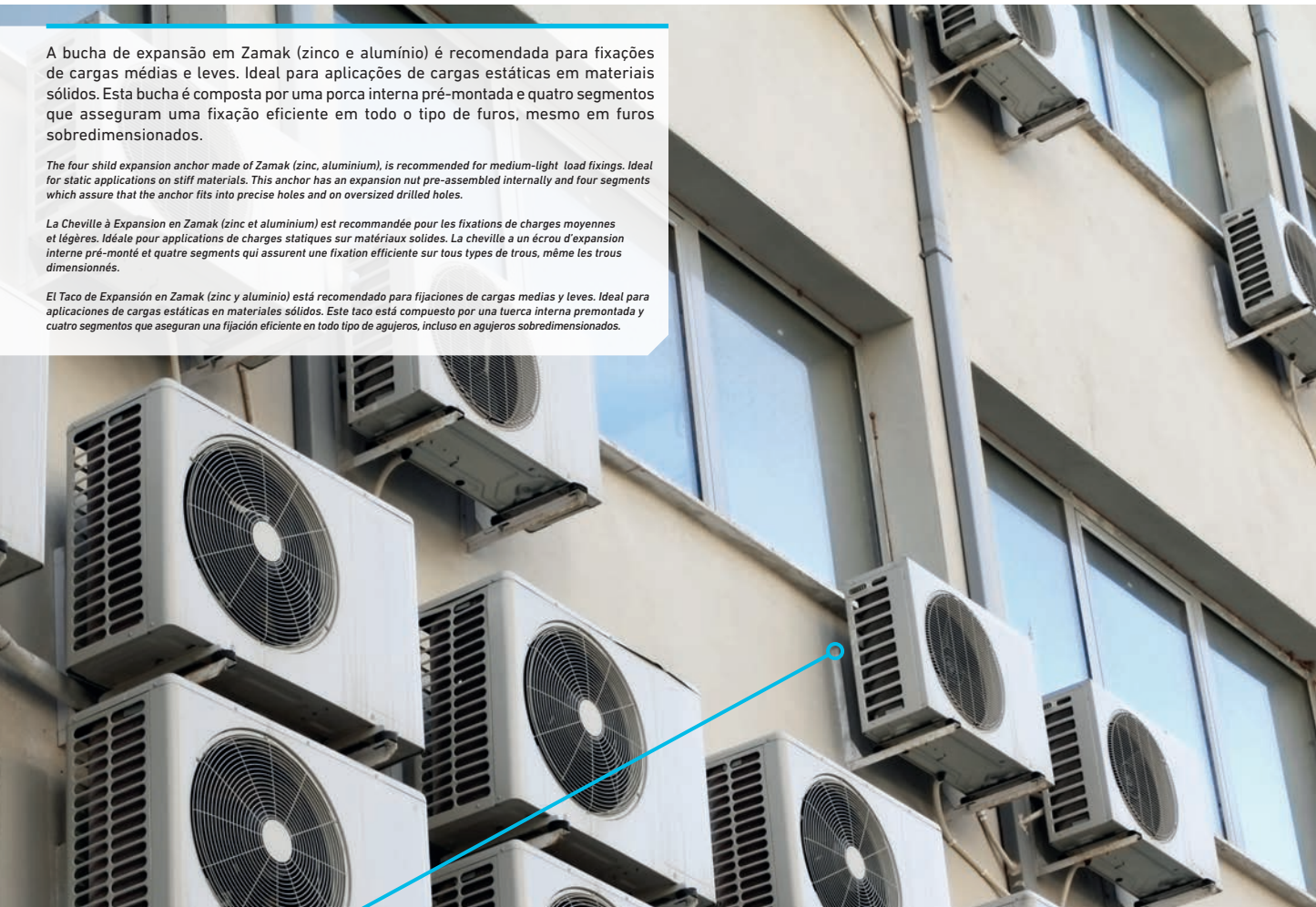

PCL 783 ZK



PCL 783

Bucha / Shild / Douille / Cápsula



CÓDIGO CODE / CODE / CÓDIGO	DIMENSÕES SIZE / DIMENSIONS / MEDIDA	COMPRIMENTO BUCHA SHILD LENGTH / LONGUEUR DOUILLE / LONGITUD CÁPSULA	EMBALAGEM QUANTITY / EMBALLAGE / EMBALAJE
078383060000	M6 x 45 Ø10	45	200
078383080000	M8 x 52 Ø14	52	100
078383100000	M10 x 60 Ø16	60	50
078383120000	M12 x 72 Ø20	72	25



Estruturas pesadas | Fixação de maquinaria | Gradeamentos | Perfis | Fachadas  
Heavy structural works | Machinery | Railings | Profiles | Building facades  
Structures lourdes | Fixation de machinerie | Grillage | Profilés | Façades  
Estructuras pesadas | Fijación de maquinaria | Enrejados | Perfiles | Fachadas



## Bucha de Expansão - 4 Segmentos

Steel Expansion Anchor - 4 Segments / Cheville à Expansion - 4 segments / Taco de Expansión Acero - 4 segmentos

# PCL 784/5/6/7/8

A bucha de expansão segmentada é recomendada para fixação de cargas médias e leves. Ideal para aplicações de forças estáticas em materiais sólidos. Esta bucha é composta por uma porca de expansão interna pré-montada e quatro segmentos que asseguram uma fixação eficiente em todo o tipo de furos, mesmo em furos sobredimensionados.

*The four segments expansion anchor is recommended for medium-light load fixings. Recommended for static applications on stiff material. This anchor has an expansion nut internally pre-assembled and the four segments which assure that fits into in precise holes and on oversized drilled holes.*

*La Cheville à Expansion segmentée est recommandée pour la fixation de charges moyennes et légères. Idéale pour des applications de forces statiques sur matériaux solides. La cheville est composée par un écrou d'expansion interne pré-monté et par quatre segments qui garantissent l'adaptation de la cheville dans tous types de trous, même trous surdimensionnés.*

*El Taco de expansión segmentado está recomendado para fijación de cargas medias y leves. Ideal para aplicaciones de fuerzas estáticas en materiales sólidos.*

*Este Taco está compuesto por una tuerca de expansión interna premontada y cuatro segmentos que aseguran una fijación eficiente en todo tipo de agujeros, incluso en agujeros sobredimensionados.*

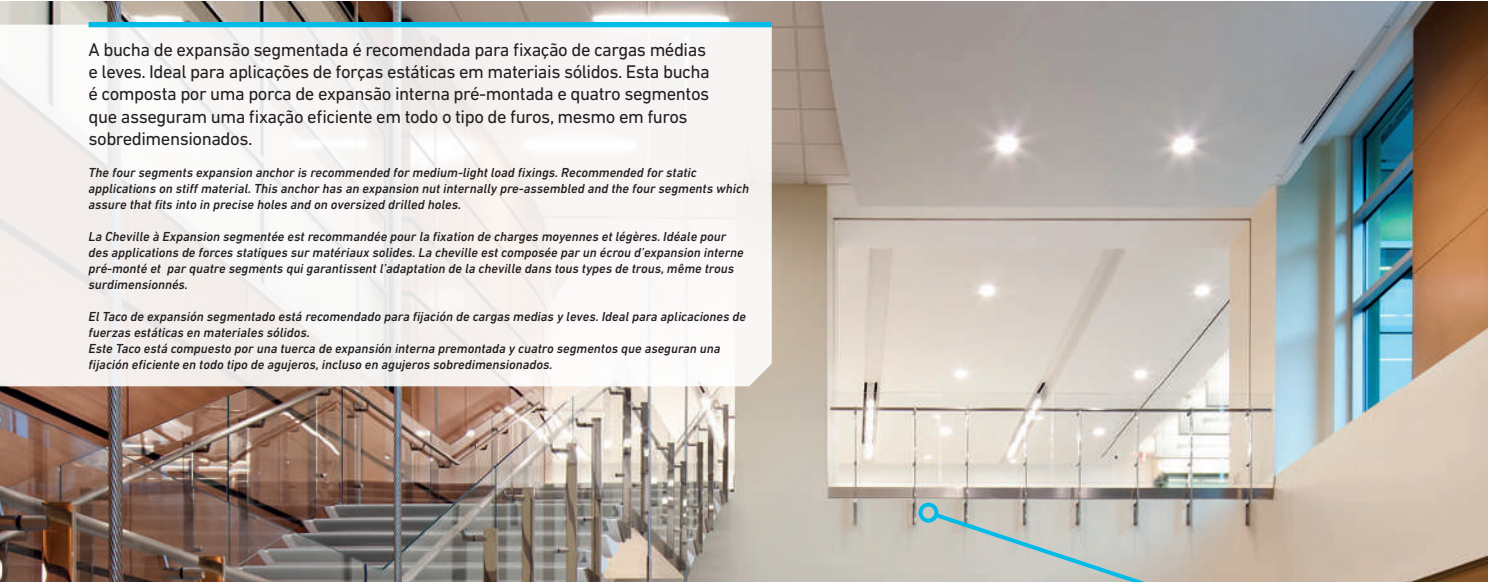

PCL 784 ZN



**Z**  
ZINC

PCL 784 A2



**A2**  
INOX

PCL 784 A4



**A4**  
INOX

PCL 785 ZN



**6.8**

**Z**  
ZINC

PCL 786 ZN



**Z**  
ZINC

PCL 787 ZN



**Z**  
ZINC

PCL 788 ZN



**Z**  
ZINC



# BUCHAS METÁLICAS

Metal anchors / Chevilles métalliques / Anclajes Metálicos

PCL 784

Zincado / Zinc plated / Zingué / Zincado



CÓDIGO CODE / CODE / CÓDIGO	DIMENSÕES SIZE / DIMENSIONS / MEDIDA	COMPRIMENTO CÁPSULA SHILD LENGTH / LONGUEUR DOUILLE / LONGITUD CÁPSULA	EMBALAGEM QUANTITY / EMBALLAGE / EMBALAJE
078423060000	M6 x 40 Ø10	40	200
078423080000	M8 x 50 Ø14	50	100
078423100000	M10 x 60 Ø16	60	50
078423120000	M12 x 80 Ø20	80	25
078423160000	M16 x 100 Ø25	100	15



**Estruturas pesadas | Fixação de maquinaria | Gradeamentos | Perfis | Fachadas**  
 Heavy structural works | Machinery | Railings | Profiles | Building facades  
 Structures lourdes | Fixation de machinerie | Grilles | Profils | Façades  
 Estructuras pesadas | Fijación de maquinaria | Enrejados | Perfiles | Fachadas

PCL 784

Aço inox A2 / Stainless steel A2 / Inoxydable A2 / Inoxidable A2



CÓDIGO CODE / CODE / CÓDIGO	DIMENSÕES SIZE / DIMENSIONS / MEDIDA	COMPRIMENTO CÁPSULA SHILD LENGTH / LONGUEUR DOUILLE / LONGITUD CÁPSULA	EMBALAGEM QUANTITY / EMBALLAGE / EMBALAJE
078461060000	M6 x 40 Ø10	40	200
078461080000	M8 x 50 Ø14	50	50
078461100000	M10 x 60 Ø16	60	50
078461120000	M12 x 80 Ø20	80	20



**Estruturas pesadas | Fixação de maquinaria | Gradeamentos | Perfis | Fachadas**  
 Heavy structural works | Machinery | Railings | Profiles | Building facades  
 Structures lourdes | Fixation de machinerie | Grilles | Profils | Façades  
 Estructuras pesadas | Fijación de maquinaria | Enrejados | Perfiles | Fachadas

PCL 784

Aço inox A4 / Stainless steel A4 / Inoxydable A4 / Inoxidable A4



CÓDIGO CODE / CODE / CÓDIGO	DIMENSÕES SIZE / DIMENSIONS / MEDIDA	COMPRIMENTO CÁPSULA SHILD LENGTH / LONGUEUR DOUILLE / LONGITUD CÁPSULA	EMBALAGEM QUANTITY / EMBALLAGE / EMBALAJE
078471060000	M6 x 40 Ø10	40	50
078471080000	M8 x 50 Ø14	50	50
078471100000	M10 x 60 Ø16	60	25
078471120000	M12 x 80 Ø20	80	10



**Estruturas pesadas | Fixação de maquinaria | Gradeamentos | Perfis | Fachadas**  
 Heavy structural works | Machinery | Railings | Profiles | Building facades  
 Structures lourdes | Fixation de machinerie | Grilles | Profils | Façades  
 Estructuras pesadas | Fijación de maquinaria | Enrejados | Perfiles | Fachadas

PCL 785

Parafuso 6.8 / Loose bolt 6.8 / Vis 6.8 / Tornillo 6.8



CÓDIGO CODE / CODE / CÓDIGO	DIMENSÕES SIZE / DIMENSIONS / MEDIDA	COMPRIMENTO PARAFUSO SCREW LENGTH / LONGUEUR VIS / LONGITUD TORNILLO	EMBALAGEM QUANTITY / EMBALLAGE / EMBALAJE
078523060500	M6 x 40 Ø10	M6 x 50	100
078523080600	M8 x 50 Ø14	M8 x 60	50
078523100800	M10 x 60 Ø16	M10 x 80	50
078523120900	M12 x 80 Ø20	M12 x 90	25
078523121000	M12 x 80 Ø20	M12 x 100	50
078523161200	M16 x 100 Ø20	M16 x 120	10



**Estruturas pesadas | Fixação de maquinaria | Gradeamentos | Perfis | Fachadas**  
 Heavy structural works | Machinery | Railings | Profiles | Building facades  
 Structures lourdes | Fixation de machinerie | Grilles | Profils | Façades  
 Estructuras pesadas | Fijación de maquinaria | Enrejados | Perfiles | Fachadas



Espárrago / Tige filetée / Projecting bolt / Haste roscada

PCL 786

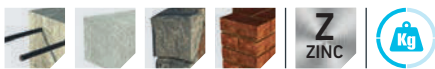

CÓDIGO CODE / CODE / CÓDIGO	DIMENSÕES SIZE / DIMENSIONS / MEDIDA	DIMENSÃO HASTE ROSCADA PROJECTING BOLT SIZE / DIMENSION TIGE FILETÉE / LONGI- TUD ESPÁRRAGO	EMBALAGEM QUANTITY / EMBALLAGE / EMBALAJE
078623060650	M6 x 40 Ø10	M6 x 65	50
078623080750	M8 x 50 Ø14	M8 x 75	50
078623100950	M10 x 60 Ø16	M10 x 95	50



**Estruturas pesadas | Fixação de maquinaria | Gradeamentos | Perfis | Fachadas**

Heavy structural works | Machinery | Railings | Profiles | Building facades  
Structures lourdes | Fixation de machinerie | Grillages | Profils | Façades  
Estructuras pesadas | Fijación de maquinaria | Enrejados | Perfiles | Fachadas

Gancho / Crochet / Hook bolt / Camarão

PCL 787



CÓDIGO CODE / CODE / CÓDIGO	DIMENSÕES SIZE / DIMENSIONS / MEDIDA	ABERTURA CAMARÃO APERTURE HOOK / OUVERTURE CROCHET / APERTURA GANCHO	EMBALAGEM QUANTITY / EMBALLAGE / EMBALAJE
078723060650	M6 x 40 Ø10	10	50
078723080600	M8 x 50 Ø14	11	50
078723100730	M10 x 60 Ø16	14	25
078723120900	M12 x 80 Ø20	17	25



**Estruturas pesadas | Fixação de maquinaria | Gradeamentos | Perfis | Fachadas**

Heavy structural works | Machinery | Railings | Profiles | Building facades  
Structures lourdes | Fixation de machinerie | Grillages | Profils | Façades  
Estructuras pesadas | Fijación de maquinaria | Enrejados | Perfiles | Fachadas

Argola / Piton / Eye bolt / Pitão

PCL 788



CÓDIGO CODE / CODE / CÓDIGO	DIMENSÕES SIZE / DIMENSIONS / MEDIDA	Ø PITÃO EYE BOLT Ø / Ø OEIL / Ø OJO	EMBALAGEM QUANTITY / EMBALLAGE / EMBALAJE
078823060650	M6 x 40 Ø10	10	50
078823080600	M8 x 50 Ø14	11	50
078823100730	M10 x 60 Ø16	12,5	25
078823120900	M12 x 80 Ø20	14	15



**Estruturas pesadas | Fixação de maquinaria | Gradeamentos | Perfis | Fachadas**

Heavy structural works | Machinery | Railings | Profiles | Building facades  
Structures lourdes | Fixation de machinerie | Grillages | Profils | Façades  
Estructuras pesadas | Fijación de maquinaria | Enrejados | Perfiles | Fachadas



# BUCHAS METÁLICAS

Metal anchors / Chevilles métalliques / Anclajes Metálicos

## PCL 790

### Bucha Metálica de Expansão HD

Taco Metálico de Expansão HD / Cheville Métallique à Expansion HD / Heavy-Duty Sleeve Anchor With Screw 8.8

Bucha de expansão de alto desempenho para aplicações pesadas em betão fissurado e não fissurado.

Recomendada para cargas dinâmicas em materiais sólidos.

Quando o parafuso sextavado é apertado a porca cônica é puxada e faz com que a bucha expanda no interior das paredes do furo.

A anilha em poliamida a meio do corpo da bucha evita a rotação durante o processo de instalação e proporciona maior desempenho do binário de aperto.

*High performance expansion anchor for heavy duty applications in both cracked and non cracked concrete. Recommended for dynamic load on solid materials. When the hexagon screw is tightened the conical nut is pulled into the expansion sleeve and expands tensioning it against the inside walls of the hole. The red plastic ring avoids the anchor rotation during the installation process and provide a good performance on torque tightening.*

*Cheville à expansion de haute performance pour applications lourdes en béton fissuré et non fissuré. Recommandée pour charges dynamiques en matériaux solides. Quand la vis six-pans est serrée l'écrou conique est tiré et fait la cheville s'expandre dans l'intérieur des parois du trou. La rondelle en polypropylène au milieu du corps de la cheville évite la rotation pendant la procédure d'installation et offre une plus grande performance du couple de serrage.*

*Taco de expansión de alto rendimiento para aplicaciones pesadas tanto en hormigón fisurado como no fisurado. Recomendado para cargas dinámicas en materiales sólidos. Cuando se aprieta el tornillo hexagonal el cono hace que el taco expanda en el interior de las paredes del agujero. El casquillo de nylon central evita la rotación durante el proceso de instalación y proporciona mayor rendimiento de la llave al aplicar el par de apriete.*



PCL 790

Homologação ETA opção 1 / Option 1 ETA approved / Homologuée ATE Option 1 / Homologado ETA Opción 1

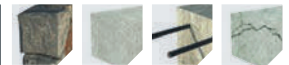

CÓDIGO CODE / CODE / CÓDIGO	DIMENSÕES SIZE / DIMENSIONS / MEDIDA	ESPESSURA MÁX. A FIXAR MAX. FIXTURE THICKNESS / ÉPAISSEUR MAX. À FIXER / ESPOSOR MÁX. A FIJAR	EMBALAGEM QUANTITY / EMBALLAGE / EMBALAJE
079023060700	M6 x 70	5	50
079023060800	M6 x 80	15	50
079023061000	M6 x 100	35	50
079023061200	M6 x 120	55	25
079023080800	M8 x 80	10	50
079023080900	M8 x 90	20	50
079023081000	M8 x 100	30	50
079023081200	M8 x 120	50	25
079023081400	M8 x 140	70	25
079023100900	M10 x 90	10	25
079023101000	M10 x 100	20	25
079023101200	M10 x 120	40	25
079023101300	M10 x 130	50	25
079023121100	M12 x 110	10	10
079023121200	M12 x 120	20	10
079023121250	M12 x 125	25	10
079023121500	M12 x 150	50	10
079023161400	M16 x 140	25	5
079023161650	M16 x 165	50	5



Estruturas pesadas | Gradeamentos | Portões | Mobiliário urbano | Escadas | Maquinaria  
Heavy structure works | Railing | Gates | Urban Furniture | Stairs | Machines  
Structures lourdes | Grilles | Portails | Mobilier urbain | Escaliers | Machinerie  
Estructuras pesadas | Enrejados | Portones | Mobiliario urbano | Escaleras | Maquinaria





## Bucha de Latão PCL 700

Brass Anchor PCL 700 / Cheville en Laiton PCL 700 / Taco de Latón PCL 700

# PCL 700



CÓDIGO CODE / CODE / CÓDIGO	DIMENSÕES SIZE / DIMENSIONS / MEDIDA	COMPRIMENTO LENGTH / LONGUEUR / LONGITUD	EMBALAGEM QUANTITY / EMBALLAGE / EMBALAJE
050051040000	M4 Ø5	15	500
050051050000	M5 Ø6	20	500
050051060000	M6 Ø8	23	200
050051080000	M8 Ø10	28	200
050051100000	M10 Ø12	32	200
050051200000	M12 Ø15	38	100

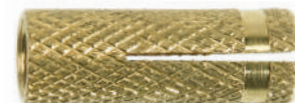

**Tetos falsos | Gradeamentos | Perfis | Escadas | Pilares de madeira**  
*Suspending drywall ceiling | Railing | Profiles | Stairs | Wood columns*  
*Faux-plafonds | Grillage | Profilés | Escaliers | Piliers en bois*  
*Techos falsos | Enrejados | Perfiles | Escaleras | Pilares de madera*



## Taco Rastrel PCL 325

Express nail PCL 325 / Cheville rastrel PCL 325 / Taco rastrel PCL 325

# PCL 325



CÓDIGO CODE / CODE / CÓDIGO	DIMENSÕES SIZE / DIMENSIONS / MEDIDA	ESPESSURA MÁX. A FIXAR MAX. FIXTURE THICKNESS / ÉPAISSEUR MAX. À FIXER / ESPESOR MÁX. A FIJAR	EMBALAGEM QUANTITY / EMBALLAGE / EMBALAJE
032513060500	6 x 50 Ø6	20	200
032513060600	6 x 60 Ø6	30	200
032513060800	6 x 80 Ø6	50	200
032513080700	8 x 70 Ø8	30	100
032513080900	8 x 90 Ø8	50	100
032513081100	8 x 110 Ø8	70	100
032513081300	8 x 130 Ø8	90	100
032513081500	8 x 150 Ø8	110	100



**Ripas para pisos de betão**  
*Battens to concrete floors*  
*Liteaux aux planchers en béton*  
*Rastreles a suelos de hormigón*



## Bucha com Olhal PCL 755

Ceiling wire hanger PCL 755 / Cheville à œillet PCL 755 / Taco con Ojal PCL 755

# PCL 755



CÓDIGO CODE / CODE / CÓDIGO	DIMENSÕES SIZE / DIMENSIONS / MEDIDA	EMBALAGEM QUANTITY / EMBALLAGE / EMBALAJE
075523060600	6 x 60	100



**Tetos falsos | Gradeamentos | Perfis | Escadas | Pilares de madeira**  
*Suspending drywall ceiling | Railing | Profiles | Stairs | Wood columns*  
*Faux-plafonds | Grillage | Profilés | Escaliers | Piliers en bois*  
*Falsos techos | Enrejados | Perfiles | Escaleras | Pilares de madera*

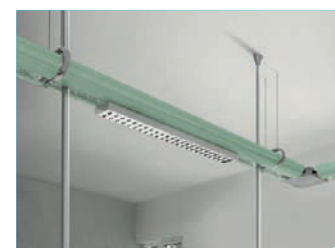



# BUCHAS METÁLICAS

Metal anchors / Chevilles métalliques / Anclajes Metálicos

## PCL 650

### Parafuso para Betão

Concrete screw anchor / Vis à béton / Anclaje de roscaado directo a hormigón



CÓDIGO CODE / CODE / CÓDIGO	DIMENSÕES SIZE / DIMENSIONS / MEDIDA	FUROS HOLES / TROUS / AGUJEROS	ESPESSURA MÁX. A FIXAR MAX. FIXTURE THICKNESS / ÉPAISSEUR MAX. À FIXER / ESPESOR MÁX. A FIJAR	EMBALAGEM QUANTITY / EMBALLAGE / EMBALAJE
065029750600	7,5x60	6	15	100
065029750800	7,5x80	6	25	100
065029751000	7,5x100	6	40	100
065029751200	7,5x120	6	50	100
065029100600	10x60	8	15	50
065029100800	10x80	8	25	50
065029101000	10x100	8	40	50
065029101200	10x120	8	50	50
065029101400	10x140	8	60	50



**Estantes | Balaustres | Condutas de ventilação | Calhas técnicas**

Racking | Railing | Ventilation tubes | Cable rails  
Soutirage | Balustrades | Conduits de Ventilation | Goutottes techniques  
Estanterías | Barandillas | Conductos de ventilación | Bandejas





## Parafuso para Betão

Concrete screw / Vis pour béton / Tornillo para hormigón

# PCL 6929

Tornillo / Vis / Screw / Parafuso

PCL 6929



CÓDIGO CODE / CODE / CÓDIGO	DIMENSÕES SIZE / DIMENSIONS / MEDIDA		Ø BROCA DRILL / FORET / BROCA	EMBALAGEM QUANTITY / EMBALLAGE / EMBALAJE
692922650320	6,5 x 32 Ø5	8	5	500
692922650450	6,5 x 45 Ø5	8	5	250
692922650570	6,5 x 57 Ø5	8	5	200
692922650700	6,5 x 70 Ø5	8	5	200
692922650800	6,5 x 80 Ø5	8	5	200
692922651000	6,5 x 100 Ø5	8	5	100
692922651250	6,5 x 125 Ø5	8	5	100



### Painéis sanduíche | Caixilharia de portas e janelas

Sandwich panels | Doorframes and windows  
Panneaux sandwich | Cadres de portes et fenêtres  
Paneles sandwich | Marcos de puertas y ventanas

## Parafuso com anilha em EPDM

Screw with vulcanized EPDM-steel washer / Vis avec rondelle d'étanchéité vulcanisée, acier EPDM / Tornillo con arandela vulcanizada de acero-EPDM

PCL 6929 + EPDM



CÓDIGO CODE / CODE / CÓDIGO	DIMENSÕES SIZE / DIMENSIONS / MEDIDA		Ø BROCA DRILL / FORET / BROCA	EMBALAGEM QUANTITY / EMBALLAGE / EMBALAJE
692922650321	6,5 x 32 P18 Ø5	8	5	500
692922650451	6,5 x 45 P18 Ø5	8	5	250
692922650571	6,5 x 57 P18 Ø5	8	5	200
692922650701	6,5 x 70 P18 Ø5	8	5	200
692922650801	6,5 x 80 P18 Ø5	8	5	200
692922651003	6,5 x 100 P18 Ø5	8	5	100
692922651251	6,5 x 125 P18 Ø5	8	5	100



### Painéis sanduíche | Caixilharia de portas e janelas

Sandwich panels | Doorframes and windows  
Panneaux sandwich | Cadres de portes et fenêtres  
Paneles sandwich | Marcos de puertas y ventanas





# BUCHAS METÁLICAS

Metal anchors / Chevilles métalliques / Anclajes Metálicos

## Pitão para Andaimos

Scaffolding anchoring / Piton pour échafaudages / Argolla para Andamios



CÓDIGO CODE / CODE / CÓDIGO	DIMENSÕES SIZE / DIMENSIONS / MEDIDA	PROFUNDIDADE MÍN. DE FURO HOLE DEPTH MIN. / PROFONDEUR MIN. / PROFUNDIDAD MÍN. DE TALADRO	PROFUNDIDADE MÍN. DE ANCORAGEM MIN. ANCHOR DEPTH / MIN. PROFONDEUR CHEVILLE / PROFUNDIDAD MÍN. DEL ANCLAJE	Ø PITÃO EYE BOLT Ø / Ø OEIL Ø OJO	EMBALAGEM QUANTITY / EMBALLAGE / EMBALAJE
000113212301	12 x 120	150	140	23	25
000112212301	12 x 190	220	210	23	25



**Fixação para andaime**  
Scaffolding anchoring  
Fixation échafaudages  
Fijación de andamios

## PCL 500

### Bucha Universal para Materiais de Construção Sólidos PCL 500

Universal Plug for Solid Building Materials PCL 500 / Cheville Universelle pour Matériaux de Construction Solides PCL 500 / Taco Universal para Materiales de Construcción Sólidos PCL 500

PCL 500

Com bordo / Rimmed / Avec collerette / Con collarin



CÓDIGO CODE / CODE / CÓDIGO	DIMENSÕES SIZE / DIMENSIONS / MEDIDA	MEDIDA PARAFUSO SCREW SIZE / DIMENSION VIS / MEDIDA TORNILLO	EMBALAGEM QUANTITY / EMBALLAGE / EMBALAJE
050011140000	M14 x 75 Ø 14	10.0 - 12.0	50
050011141000	M14 x 100 Ø 14	10.0 - 12.0	50



**Aplicações elétricas | Quadros | Caixas de correio | Calhas técnicas | Aparelhos eletrônicos**  
Electrical application | Pictures | Mailboxes | Cable ducts | Electronic appliances  
Applications électriques | Cadres | Boîtes aux lettres | Goulottes techniques | Appareils électroniques  
Aplicaciones eléctricas | Cuadros | Buzones | Canaletas técnicas | Aparatos electrónicos

PCL 500

Sem bordo / Rimless / Sans collerette / Sin collarin



CÓDIGO CODE / CODE / CÓDIGO	DIMENSÕES SIZE / DIMENSIONS / MEDIDA	MEDIDA PARAFUSO SCREW SIZE / DIMENSION VIS / MEDIDA TORNILLO	EMBALAGEM QUANTITY / EMBALLAGE / EMBALAJE
050000140000	M14 x 75 Ø 14	10.0 - 12.0	50
050000141000	M14 x 100 Ø 14	10.0 - 12.0	50



**Aplicações elétricas | Quadros | Caixas de correio | Calhas técnicas | Aparelhos eletrônicos**  
Electrical application | Pictures | Mailboxes | Cable ducts | Electronic appliances  
Applications électriques | Cadres | Boîtes aux lettres | Goulottes techniques | Appareils électroniques  
Aplicaciones eléctricas | Cuadros | Buzones | Canaletas técnicas | Aparatos electrónicos





## Poleias para Ar Condicionado

Air Conditioner Brackets / Équerres pour Climatisation / Soportes para Aire Acondicionado

# PCL 303

**Z**  
ZINC

CÓDIGO CODE / CODE / CÓDIGO	DIMENSÕES SIZE / DIMENSIONS / MEDIDA	ESPESSURA THICKNESS / ÉPAISSEUR / ESPESOR	EMBALAGEM QUANTITY / EMBALLAGE / EMBALAJE
030319365400	365 x 400	2	1+1
030319365450	365 x 450	2	1+1
030319365500	365 x 500	2	1+1



### Instalações de Ar Condicionado, Bombas e Motores

Facilities with Air Conditioning, Pumps and Motors  
Installation de climatisation, pompes et moteurs  
Instalaciones de Aire Acondicionado, Bombas y Motores



## Acessórios / Accessory / Accessoire / Accesorio

**Cinobloco** / Rubber pads / Plot Anti-vibration / Antivibrante



CÓDIGO CODE / CODE / CÓDIGO	CAPACIDADE SIZE / DIMENSIONS / DIMENSÕES	EMBALAGEM QUANTITY / EMBALLAGE / EMBALAJE
030600000001	35 kg	4
030600000002	90 kg	4

**PCL 941 - Porca de Gaiola M8** / Cage nut M8 / Écrou Cage M8 / Tuerca de Jaula M8



**Z**  
ZINC

CÓDIGO CODE / CODE / CÓDIGO	DIMENSÕES SIZE / DIMENSIONS / MEDIDA	EMBALAGEM QUANTITY / EMBALLAGE / EMBALAJE
094112080002	1.8 - 3.2	500
094112080004	1.8 - 3.2	500 (125 x 4)

## Chumbadores (Olhal com Fiel Montado)

Hinge with Stud Mounted / Paumelle (Oillet avec Tige en Fer Montée) / Bisagra c/ Pasador de Hierro Montado

**Fe**

CÓDIGO CODE / CODE / CÓDIGO	DIMENSÕES SIZE / DIMENSIONS / MEDIDA	FIEL STUD / TIGE / PASADOR	EMBALAGEM QUANTITY / EMBALLAGE / EMBALAJE
000011325538	50 x 11	6	25
000011325539	76 x 12	6	25
000011325540	76 x 15	8	25
000011325541	80 x 15	8	25
000011325542	90 x 15	8	25
000011325536	90 x 18,5	9	25
000011325537	85 x 21,5	11	25
000011325543	100 x 20	11	25
000011325508	113 x 25	11	25
000011325544	120 x 20	11	25
000011325515	125 x 25	14	25



### Fixação de portões a muros | Fixação de grades de segurança à parede

Fixing to doors and gates to walls | Fixing security grids to the wall  
Fixation de portails aux murs | Fixation de grilles de sécurité au mur  
Fijación de portones a muros | Fijación de rejas de seguridad a la pared





**O SEU FORNECEDOR DE SEMPRE,  
ONDE ESTIVER!**

*/ Your ever-ready supplier, wherever you are! / Votre fournisseur de toujours, où que vous soyez! / Su proveedor de siempre, donde esté!*

[HTTP://STORE.PECOL.PT/](http://store.pecol.pt/)

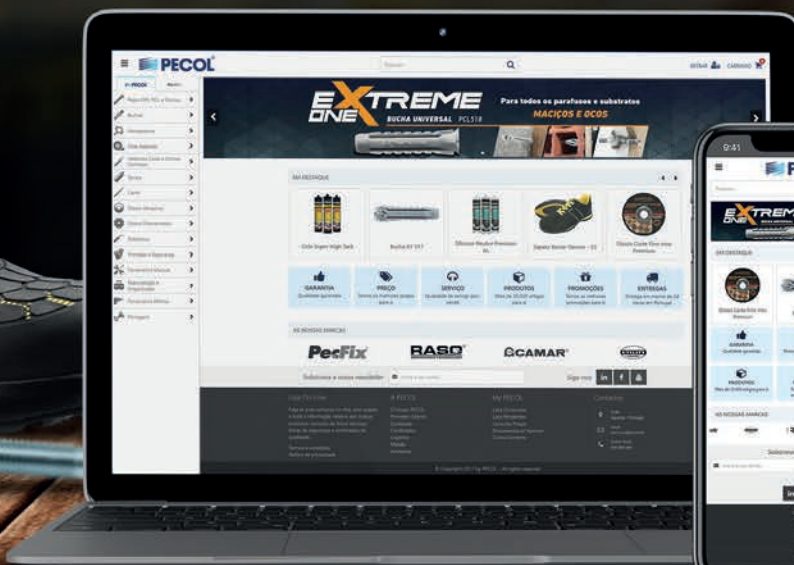

# BUCHAS QUÍMICAS



CHEMICAL ANCHORS  
FIXATIONS CHIMIQUES  
ANCLAJES QUÍMICOS



# BUCHAS QUÍMICAS

Chemical Anchors / Fixations Chimiques / Anclajes Químicos

# BUCHAS QUÍMICAS

Chemical Anchors  
/ Fixations chimiques  
/ Anclajes Químicos



## PREMIUM

### BUCHA QUÍMICA VINÍLICA Sem Estireno

Vinylester Styrene Free Chemical Anchor  
Mortier de Scellement Vinylester Sans Styrene  
Taco Químico Vinílico Sin Estireno



#### MATERIAL BASE

/ Base material / Matériaux base / Material base

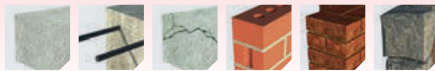

#### RESISTÊNCIA À TRAÇÃO RECOMENDADA \*\*

/ Recommended tensile loads / Charges admissibles à la traction / Resistencias recomendadas a tracción

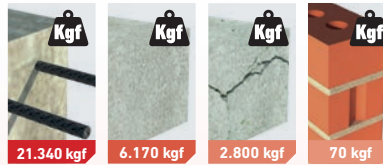

VÁLIDO PARA / Valid for / Valable pour / Válido para

Ø8 - Ø32

AÇO NERVORADO  
/ Reinforcing bar / Fer à béton  
/ Barra corrugada



M8 - M30

VARÃO ROSCADO  
/ Threaded rod / Tige fileté  
/ Varilla roscada



#### CONDIÇÕES DO FURO

/ Hole condition / Condition du trou / Condición del taladro



## SPECIAL

### BUCHA QUÍMICA EPOXI ACRILATO Sem Estireno

Epoxy Acrylate Styrene Free Chemical Anchor  
Mortier de Scellement Epoxy Acrylate Sans Styrene  
Taco Químico Epoxi Acrilato Sin Estireno



#### MATERIAL BASE

/ Base material / Matériaux base / Material base

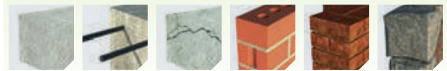

#### RESISTÊNCIA À TRAÇÃO RECOMENDADA \*\*

/ Recommended tensile loads / Charges admissibles à la traction / Resistencias recomendadas a tracción



VÁLIDO PARA / Valid for / Valable pour / Válido para

Ø8 - Ø25

AÇO NERVORADO\*  
/ Reinforcing bar\* / Fer à béton\*  
/ Barra corrugada\*



M8 - M24

VARÃO ROSCADO  
/ Threaded rod / Tige fileté  
/ Varilla roscada



#### CONDIÇÕES DO FURO

/ Hole condition / Condition du trou / Condición del taladro







**SPECIAL**

**BUCHA QUÍMICA EPOXI ACRILATO**

Epoxy Acrylate Chemical Anchor  
Mortier de Scellement Epoxy Acrylate  
Taco Químico Epoxi Acrilato



**MATERIAL BASE**

/ Base material / Matériaux base / Material base



**RESISTÊNCIA À TRAÇÃO RECOMENDADA \*\***

/ Recommended tensile loads / Charges admissibles à la traction / Resistencias recomendadas a tracción



VÁLIDO PARA / Valid for / Valable pour / Válido para

**M8 - M24**

**VARÃO ROSCADO**  
/ Threaded rod  
/ Tige filetée  
/ Varilla roscada



**CONDIÇÕES DO FURO**

/ Hole condition / Condition du trou / Condición del taladro



**CLASSIC**

**BUCHA QUÍMICA POLIÉSTER Sem Estireno**

Polyester Styrene Free Chemical Anchor  
Mortier de Scellement Polyester Sans Styrene  
Taco Químico Poliéster Sin Estireno



SEM ESTIRENO  
STYRENE FREE / SANS STYRÈNE  
SIN ESTIRENO



**MATERIAL BASE**

/ Base material / Matériaux base / Material base



**RESISTÊNCIA À TRAÇÃO RECOMENDADA \*\***

/ Recommended tensile loads / Charges admissibles à la traction / Resistencias recomendadas a tracción



VÁLIDO PARA / Valid for / Valable pour / Válido para

**M8 - M24**

**VARÃO ROSCADO**  
/ Threaded rod  
/ Tige filetée  
/ Varilla roscada



**CONDIÇÕES DO FURO**

/ Hole condition / Condition du trou / Condición del taladro



**BUCHA QUÍMICA POLIÉSTER**

Polyester Chemical Anchor  
Mortier de Scellement Polyester  
Taco Químico Poliéster



**MATERIAL BASE**

/ Base material / Matériaux base / Material base



**RESISTÊNCIA À TRAÇÃO RECOMENDADA \*\***

/ Recommended tensile loads / Charges admissibles à la traction / Resistencias recomendadas a tracción



VÁLIDO PARA / Valid for / Valable pour / Válido para

**M8 - M24**

**VARÃO ROSCADO**  
/ Threaded rod  
/ Tige filetée  
/ Varilla roscada



**CONDIÇÕES DO FURO**

/ Hole condition / Condition du trou / Condición del taladro





# BUCHAS QUÍMICAS

Chemical Anchors / Fixations Chimiques / Anclajes Químicos

## Bucha Química Vinílica Sem Estireno Premium

Vinylester Styrene Free Chemical Anchor Premium / Mortier de Scellement Vinylester Sans Styrene Premium / Taco Químico Vinílico Sin Estireno Premium

**FREE**  
SIN ESTIRENO  
STYRENE FREE  
/ SANS STYRENE  
/ SENN ESTIRENO

**LEGO TINTO**

**F120**

**SEISMIC C1**

**CRACKED CONCRETE**

**ETA CE**  
European Technical Assessment

**ETA option 1 with Seismic C1**

**ETA TR023 (Rebar)**

**ETA ETAG029**

**EMISSIONS DANS L'AIR INTÉRIEUR**  
**A+**



Bucha Química Vinílica sem Estireno com excelentes propriedades para efetuar fixações em substratos sólidos e/ou ocos, com um curto período de cura.

É um produto com dois componentes (resina e endurecedor), adequado para aplicar em betão fissurado e não fissurado (até em eventos sísmicos), pedra, tijolo perfurado, em variados tipos de aplicação.

É ainda utilizada para aplicações estruturais com barras reforçadas, em construções e/ou remodelações em obras diversas.

O cartucho de 300ml pode ser extrudido com uma pistola standard utilizada para cartuchos de selantes.

### Características

- Isento de Estireno, amigo do ambiente;
- Produto de fácil extrusão e injeção;
- Tixotrópica, pode ser aplicada na horizontal e/ou na vertical;
- Resistente a temperaturas até +50°C e por curtos períodos até +80°C;
- Cura rápida;
- Possibilidade de aplicação nas extremidades dos substratos;
- Reduzido diâmetro de brocas (p.e. para um Varão Roscado M20, é preciso um furo de 22 mm e para M24 é preciso um furo de 26 mm, tornando-se num sistema de injeção económico).



**i** Dados técnicos e ficha de segurança disponível sob pedido  
/ Technical information and safety data sheet available under request / Données techniques et fiche de données de sécurité disponible sur demande / Datos técnicos y ficha de seguridad disponible bajo pedido  
dep.tecnico@pecol.pt

CÓDIGO CODE / CODE / CÓDIGO	CAPACIDADE CAPACITY / CAPACITÉ / CAPACIDAD	EMBALAGEM QUANTITY / EMBALLAGE / EMBALAJE	QTD. PALETTE PALET / QT. PALLETTE / CANT. PALÉ
004001030000	300 ml	12	1152
004001004100	410 ml	12	840

Vinylester styrene free chemical anchor is a high performance injection mortar for solid and hollow base materials having a short cure time. This is a two components product (resin and hardener) suitable for use in cracked and non-cracked concrete (even in seismic conditions), stone, perforated bricks and cavity blocks in a wide range of applications. It is also suitable for structural applications with reinforcing bars in new construction work or refurbishment. It can be extruded with a mastic gun (only for 300ml cartridge)

### Characteristics

- Styrene free, very low odour;
- Easy to extrude and to inject;
- Thixotropic, can be applied in vertical or horizontal direction;
- Temperature resistance: +80°C short term and +50°C long term;
- Fast curing;
- Fixing close to free edges, allowing anchoring in critical cases;
- Reduced drill diameters i.e. M20 only requires a 22 mm hole and M24 a 26 mm hole, making it an economical injection system.

Le mortier de scellement Chimique Vinylester Sans Styrene possède d'excellentes propriétés pour la fixation de charges lourdes en supports pleins et/ou creux et offre un temps de prise rapide. C'est un mortier bi-composants (résine et durcisseur), adéquat pour tout type d'applications (sismiques incluses) dans le béton fissuré et non fissuré, pierre, brique creuse. Idéal pour des applications structurelles avec des barres d'acier haute adhérence en constructions neuves et/ou rénovation. Les cartouches 300ml s'extrudent avec un pistolet standard pour cartouches de mastic.

### Características

- Sans styrene, faible odeur;
- Confort d'extrusion et facilité d'injection;
- Tixotropique, peut être utilisé horizontalement ou verticalement;
- Performances stables à des températures jusqu'à +50°C (long terme) et jusqu'à +80°C (court terme);
- Prise rapide;
- Pose près des bords de dalle;
- Diamètre réduit des forets (p. ex.: pour une tige fileté M20, perçage 22 mm, au lieu de 24 ou 25 mm et 26 mm en M24 au lieu de 28 mm, ce qui en fait un système d'injection économique).

El Taco Químico Vinílico sin Estireno, tiene excelentes propiedades para la fijación en materiales bases macizos y/o huecos, con fraguado rápido. Es un mortero bicomponente (resina y endurecedor), adecuado para aplicaciones en hormigón fisurado y no fisurado (incluso en zonas sísmicas), piedra, ladrillo hueco, ladrillo macizo. También es adecuado para aplicaciones estructurales con barras corrugadas, en construcciones nuevas y/o remodelaciones. Se aplica con una pistola standard utilizada para cartuchos de silicona (sólo para cartucho de 300 ml).

### Características

- Sin Estireno;
- Producto de fácil extrusión e inyección;
- Tixotrópico, puede ser aplicado horizontalmente y/o verticalmente;
- Cargas garantizadas temperaturas hasta +50°C (plazo largo) y hasta +80°C (corto plazo);
- Tiempo de fraguado rápido;
- Ideal par fijar cerca de los bordes;
- Diámetro de brocas reducido (ej: para una Varilla Roscada M20, un agujero de 22 mm en lugar de 24 o 25 mm, habitualmente, M24 agujero de 26 mm en lugar de 28 mm, convirtiéndose en un sistema de inyección económico).

### RESISTÊNCIA À TRAÇÃO RECOMENDADA\*\*

/ Recommended tensile loads / Charges admissibles à la traction / Resistencias recomendadas a tracción

#### BETÃO

/ Concrete / Béton / Hormigón - C20/25

Kgf	M8	880 kgf
	M10	1.100 kgf
	M12	1.550 kgf
	M16	2.300 kgf
	M20	3.600 kgf
	M24	5.000 kgf
	M27	5.900 kgf
	M30	6.170 kgf

#### TIJOLO PERFURADO

/ Hollow brick / Brique creuse / Ladrillo hueco

Kgf	M8	57 kgf
	M10	57 kgf
	M12	70 kgf



VÁLIDO PARA / Valid for / Valable pour / Válido para

Ø8 - Ø32

#### AÇO NERVURADO

/ Reinforcing bar  
/ Fer à béton  
/ Barra corrugada



M8 - M30

#### VARÃO ROSCADO

/ Threaded rod  
/ Tige fileté  
/ Varilla rosçada



### INSTRUÇÕES DE USO

/ Directions of use / Mode d'emploi / Instrucciones de uso

#### MACIÇOS

/ Solid / Plein / Macizos



#### OCOS

/ Hollow / Creux / Huecos



### MATERIAL BASE

/ Base material / Matériaux base / Material base

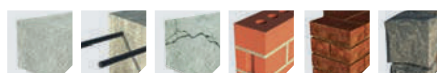

### CONDIÇÕES DO FURO

/ Hole condition / Condition du trou / Condición del taladro



### TEMPERATURA IDEAL PARA A APLICAÇÃO

/ Recommended application temperature  
/ Température de pose recommandée  
/ Temperatura recomendada de aplicación



+20°C

### TEMPERATURA MÍNIMA PARA APLICAÇÃO

/ Minimum application temperature  
/ Température de pose minimum  
/ Temperatura mínima de aplicación

+5°C



# Bucha Química Epoxi Acrilato Special

Epoxy Acrylate Chemical Anchor Special / Mortier de scellement Époxy Acrylate Special / Taco Químico Epoxi Acrilato Special

A Bucha Química Epoxi Acrilato é um produto com excelentes propriedades para a fixação em materiais maciços e/ou ocós, de cura rápida. Adequado para aplicar em betão, rocha e pedra, onde é necessária uma fixação de uma carga elevada. É ainda adequada para aplicações estruturais com aços de construção, em construções e/ou remodelações.

**Características**

- Aplicável tanto em buracos secos como húmidos (até cheios de água);
- Produto de fácil extrusão e injeção;
- Cura rápida;
- Distâncias reduzidas entre eixos e até à margem;
- Ideal para fixar perto de margens.



**Dados técnicos e ficha de segurança disponível sob pedido**  
/ Technical information and safety data sheet available under request / Données techniques et fiche de données de sécurité disponible sur demande / Datos técnicos y ficha de seguridad disponible bajo pedido  
dep.tecnico@pecol.pt

	<b>CÓDIGO</b> CODE / CODE / CÓDIGO	<b>CAPACIDADE</b> CAPACITY / CAPACITÉ / CAPACIDAD	<b>EMBALAGEM</b> QUANTITY / EMBALLAGE / EMBALAJE	<b>QTD. PALETE</b> PALET / QT. PALETTE / CANT. PALÉ
EPOXI	004001040300	300 ml	12	1152
	004001040410	410 ml	12	840
EPOXI S/ EST.	004001050300	300 ml	12	1152
	004001050410	410 ml	12	840

Epoxy Acrylate chemical anchor is a high performance injection mortar specifically formulated to cure fast and is suitable for applications in concrete, rock and stone, where a high load bearing capacity is required. It is also suitable for structural applications with reinforcing bars in new construction work on refurbishment and assembling of dowel of precast elements of concrete.

**Characteristics**

- Suitable for dry and wet holes (and flooded holes);
- Easy to extrude and to inject;
- Fast curing;
- Flexible embedment depths;
- Reduced edge and spacing distances;
- Fixing close to free edges.

Le Mortier de scellement Chimique Époxy Acrylate est un produit avec d'excellentes propriétés pour la fixation en supports pleins et/ou creux, offrant un durcissement rapide. Idéal pour application en béton, roche et pierre, là où une résistance à une charge lourde est nécessaire. Il est également adéquat pour des applications structurelles avec des fers à béton, en construction neuve et/ou rénovation.

**Caractéristiques**

- Pose en trous secs et humides (et trous immergés);
- Confort d'extrusion et facilité d'injection;
- Prise rapide;
- Faibles distances au bord et entr'axes réduits;
- Pose près des bords de dalle.

El Taco Químico Epoxi Acrilato es un mortero con excelentes propiedades para la fijación en soportes macizos y/o huecos, con fraguado rápido. Ideal para instalación en hormigón, roca y piedra, donde una resistencia a una carga pesada es necesaria. También adecuado para aplicaciones estructurales con barras corrugadas, en construcciones y/o remodelaciones.

**Características**

- Aplicable tanto en agujeros secos como húmedos (y inundados);
- Mortero de fácil extrusión y inyección;
- Fraguado rápido;
- Distancias entre ejes y al borde reducidas;
- Ideal para fijar cerca de los bordes.

**EPOXI ACRILATO SEM ESTIRENO**

**RESISTÊNCIA À TRAÇÃO RECOMENDADA\*\***  
/ Recommended tensile loads / Charges admissibles à la traction / Resistencias recomendadas a tracción

BETÃO / Concrete / Béton / Hormigón - C20/25		TJÓLO PERFORADO / Hollow brick / Brique creux / Ladrillo hueco	
<b>M8</b>	798 kgf	<b>M8</b>	70 kgf
<b>M10</b>	898 kgf	<b>M10</b>	70 kgf
<b>M12</b>	1.481 kgf	<b>M12</b>	70 kgf
<b>M16</b>	2.425 kgf		
<b>M20</b>	3.603 kgf		
<b>M24</b>	5.341 kgf		

**EPOXI**

**RESISTÊNCIA À TRAÇÃO RECOMENDADA\*\***  
/ Recommended tensile loads / Charges admissibles à la traction / Resistencias recomendadas a tracción

BETÃO / Concrete / Béton / Hormigón - C20/25		TJÓLO PERFORADO / Hollow brick / Brique creux / Ladrillo hueco	
<b>M8</b>	958 kgf	<b>M8</b>	70 kgf
<b>M10</b>	1.122 kgf	<b>M10</b>	70 kgf
<b>M12</b>	1.975 kgf	<b>M12</b>	70 kgf
<b>M16</b>	2.553 kgf		
<b>M20</b>	3.603 kgf		
<b>M24</b>	4.712 kgf		

**VÁLIDO PARA / Valid for / Valable pour / Válido para**

**Ø8 - Ø25**

**VARÃO ROSCADO**  
/ Threaded rod / Tige filetée / Varilla roscada

**M8 - M24**

**VÁLIDO PARA / Valid for / Valable pour / Válido para**

**M8 - M24**

\* NÃO INCLUIDO NA CERTIFICAÇÃO ETA / Not Part Of The Eta / Hors Ete / No Includo En La Certificación Eta

**INSTRUÇÕES DE USO**  
/ Directions of use / Mode d'emploi / Instrucciones de uso

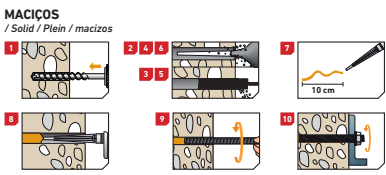

**MATERIAL BASE**  
/ Base material / Matériaux base / Material base

**CONDIÇÕES DO FURO**  
/ Hole condition / Condition du trou / Condición del taladro

**TEMPERATURA IDEAL PARA A APLICAÇÃO**  
/ Recommended application temperature / Température de pose recommandée / Temperatura recomendada de aplicación

**+20°C**

**TEMPERATURA MÍNIMA PARA APLICAÇÃO**  
/ Minimum application temperature / Température de pose minimum / Temperatura mínima de aplicación

**+5°C**



# BUCHAS QUÍMICAS

Chemical Anchors / Fixations Chimiques / Anclajes Químicos

## Bucha Química Poliéster Classic

Polyester Chemical Anchor Classic / Mortier de Scellement Polyester Classic / Taco Químico Poliéster Classic



European Technical Assessment

ETA option 7

ETA ETAG029

ÉMISSIONS DANS L'AIR INTÉRIEUR

A+

A+ A B C



Bucha Química Poliéster com excelentes propriedades para a fixação em substratos maciços e/ou ocós, com um rápido período de cura.

É um produto com dois componentes (resina e endurecedor), adequado para betão, pedra, tijolo perfurado, rocha e pedra.

A Bucha Química Poliéster foi desenvolvida para uma fácil aplicação, com elevados níveis de resistência à tração.

### Características

- Possibilidade de aplicação em substratos ocós ou maciços;
- Produto de fácil extrusão e injeção;
- Tixotrópica, pode ser aplicada nas paredes e no teto;
- Cura rápida;
- Resistente a temperaturas até +50°C e por curtos períodos até +80°C.



Dados técnicos e ficha de segurança disponível sob pedido

/ Technical information and safety data sheet available under request / Données techniques et fiche de données de sécurité disponible sur demande / Datos técnicos y ficha de seguridad disponible bajo pedido

dep.technico@pecol.pt



European Technical Assessment

ETA option 7

ÉMISSIONS DANS L'AIR INTÉRIEUR

A+

A+ A B C

	CÓDIGO CODE / CODE / CÓDIGO	CAPACIDADE CAPACITY / CAPACITÉ / CAPACIDAD	EMBALAGEM QUANTITY / EMBALLAGE / EMBALAJE	QTD. PALETE PALET / QT. PALETTE / CANT. PALÉ
POLIÉSTER	004001010300	300 ml	12	1152
	004001010410	410 ml	12	840
POLIÉSTER S/ EST.	004001028001	300 ml	12	1152
	004001041000	410 ml	12	840

Polyester chemical anchor is a general purpose injection mortar for solid and hollow supports, having a short cure time.

This is a two components product (resin and hardener) suitable for use in concrete, solid brick, hollow brick, rock and stone.

The polyester resin has been developed for ease of application and high tensile strength.

### Characteristics

- Fits standard caulking gun (300ml) and special caulking gun (410ml);
- Suitable for hollow and solid substrates;
- Easy to extrude and to inject;
- Tixotropic, can be applied in vertical or horizontal direction;
- Fast curing;
- Temperature resistance: +80°C short term and +50°C long term.

Le Mortier de Scellement Chimique Polyester possède d'excellentes propriétés pour la fixation en supports pleins et / ou creux, et est à prise rapide.

C'est un produit à deux composants (résine et durcisseur), adéquat pour le béton, pierre, brique perforée.

La Cheville Chimique Polyester a été développée pour une application facile, avec des hauts niveaux de résistance à la traction.

### Caractéristiques

- Polyvalent, pour matériaux pleins et creux;
- Confort d'extrusion et facilité d'injection;
- Tixotropique, peut être utilisé dans les murs et au plafond;
- Prise rapide;
- Performances stables à des températures jusqu'à +50°C (long terme) et jusqu'à +80°C (court terme);

El Taco Químico Poliéster con excelentes propiedades para la fijación de materiales bases macizos y/o huecos, con un rápido tiempo de fraguado.

Es un mortero con bicomponente (resina y endurecedor), adecuado para hormigón, ladrillo macizo, ladrillo hueco, roca y piedra.

El Taco Químico Poliéster ha sido desarrollado para una fácil aplicación, con elevados niveles de resistencia a la tracción.

### Características

- Posibilidad de aplicación en materiales base huecos o macizos;
- Producto de fácil extrusión e inyección;
- Tixotrópica, puede ser aplicada en paredes y en el techo;
- Fraguado rápido;
- Cargas garantizadas con temperaturas hasta +50°C (plazo largo) y por periodos cortos hasta +80°C (corto plazo).

### POLIÉSTER SEM ESTIRENO

#### RESISTÊNCIA À TRAÇÃO RECOMENDADA\*\*

/ Recommended tensile loads / Charges admissibles à la traction / Resistencias recomendadas a tracción

#### BETÃO

/ Concrete / Béton / Hormigón - C20/25

M8	678 kgf
M10	898 kgf
M12	1.481 kgf
M16	2.298 kgf
M20	3.391 kgf
M24	4.712 kgf

#### TIJOLO PERFURADO

/ Hollow brick / Brique creuse / Ladrillo hueco

M8	70 kgf
M10	70 kgf
M12	70 kgf

VÁLIDO PARA / Valid for / Valable pour / Válido para

M8 - M24

#### VARÃO ROSCADO

/ Threaded rod / Tige filetée / Varilla rosca



### POLIÉSTER

#### RESISTÊNCIA À TRAÇÃO RECOMENDADA\*\*

/ Recommended tensile loads / Charges admissibles à la traction / Resistencias recomendadas a tracción

#### BETÃO

/ Concrete / Béton / Hormigón - C20/25

M8	758 kgf
M10	1.010 kgf
M12	1.399 kgf
M16	2.042 kgf
M20	3.179 kgf
M24	4.398 kgf

#### TIJOLO PERFURADO

/ Hollow brick / Brique creuse / Ladrillo hueco

M8	70 kgf
M10	70 kgf
M12	70 kgf

VÁLIDO PARA / Valid for / Valable pour / Válido para

M8 - M24

#### VARÃO ROSCADO

/ Threaded rod / Tige filetée / Varilla rosca



### POLIÉSTER SEM ESTIRENO E POLIÉSTER

#### INSTRUÇÕES DE USO

/ Directions of use / Mode d'emploi / Instrucciones de uso

#### MACIÇOS

/ Solid / Plein / Macizos



#### OCÓS

/ Hollow / Creux / Huecos



#### MATERIAL BASE

/ Base material / Matériaux base / Material base



#### CONDIÇÕES DO FURO

/ Hole condition / Condition du trou / Condición del taladro



#### TEMPERATURA IDEAL PARA A APLICAÇÃO

/ Recommended application temperature / Température de pose recommandée / Temperatura recomendada de aplicación

+20°C

#### TEMPERATURA MÍNIMA PARA APLICAÇÃO

/ Minimum application temperature / Température de pose minimum / Temperatura mínima de aplicación

+5°C

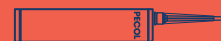

## Haste rosca para fixação química, com porca e anilha

Stud bolt for chemical anchor, with nut and washer / Tige filetée pour scellement chimique avec rondelle et écrou / Esparrago para anclaje químico con tuerca y arandela

CÓDIGO CODE / CODE / CÓDIGO	DIMENSÕES SIZE / DIMENSIONS / MEDIDA	COMPRIMENTO LENGTH / LONGUEUR / LONGITUD	Ø BROCA DRILL / FORET/ BROCA	EMBALAGEM QUANTITY / EMBALLAGE / EMBALAJE
00402000000	M8 x 110	110	10	10
00402100000	M10 x 130	130	12	10
00402200000	M12 x 160	160	14	10
00402300000	M16 x 190	190	18	10
00402400000	M20 x 260	260	25	6
00402500000	M24 x 300	300	28	6
00402600000	M30 x 330	330	35	6



## Acessórios para Bucha Química

Accessories for Chemical Anchor / Accessoires pour Chevilles Chimiques / Accesorios para Anclajes Químicos

Cleaning Blow Pump / Pompe à Air / Bomba de Aire

Bomba de Ar

Dispenser Gun / Pistolets / Pistolas

Pistolas

CÓDIGO CODE / CODE / CÓDIGO	EMBALAGEM QUANTITY / EMBALLAGE / EMBALAJE
00401200000	12



CÓDIGO CODE / CODE / CÓDIGO	EMBALAGEM QUANTITY / EMBALLAGE / EMBALAJE
00500200000	12



300 ml

CÓDIGO CODE / CODE / CÓDIGO	EMBALAGEM QUANTITY / EMBALLAGE / EMBALAJE
00400400000	12



380/410 ml

Cleaning Brush / Brosse circulaire / Escobilla de Limpieza

Escovilhão de Limpeza

Mixing Nozzle / Embout Mélangeur / Cánula Mezcladora

Ponta Misturadora

CÓDIGO CODE / CODE / CÓDIGO	DIMENSÕES SIZE / DIMENSIONS / MEDIDA	EMBALAGEM QUANTITY / EMBALLAGE / EMBALAJE
00401000000	12 mm	12



CÓDIGO CODE / CODE / CÓDIGO	EMBALAGEM QUANTITY / EMBALLAGE / EMBALAJE
00400200000	12



Plastic Sleeves / Chemise de Nylon / Tamiz de Nylon

Camisa de Nylon

Internal Threaded Sockets / Chemise Métallique / Tamiz Metálico

Camisa Metálica

CÓDIGO CODE / CODE / CÓDIGO	DIMENSÕES SIZE / DIMENSIONS / MEDIDA	EMBALAGEM QUANTITY / EMBALLAGE / EMBALAJE
00400500000	M12 x 60	12
00400600000	M16 x 85	12
00400700000	M16 x 130	12
00400800000	M20 x 85	12



CÓDIGO CODE / CODE / CÓDIGO	DIMENSÕES SIZE / DIMENSIONS / MEDIDA	EMBALAGEM QUANTITY / EMBALLAGE / EMBALAJE
00401300000	6 x 48	100
00401400000	8 x 80	100
00401500000	10 x 80	100
00401600000	12 x 80	50





# BUCHAS QUÍMICAS

Chemical Anchors / Fixations Chimiques / Anclajes Químicos

## Malas de Bucha Química

Chemical Anchor KIT / Valises de Cheville Chimique / Maleta de Taco Químico



### Special

Special / Special / Special



CÓDIGO CODE / CODE / CÓDIGO		DIMENSÕES SIZE / DIMENSIONS / MEDIDA
00400000001	x1 Malas de Bucha Química / Blow moulded site polypropilene / Valises de Cheville Chimique / Maleta de taco químico	500 x 360 x 120
	x2 Bucha Química Vinílica sem Estireno Premium / Chemical anchor Vinylester Styrene Free Premium / Cheville Chimique Vinylique sans Styrene Premium / Taco Químico Vinílico sin Estireno Premium	300 ml
	x1 Pistola para silicone Special / Caulking gun Special / Pistolet à Mastic Special / Pistola para silicona Special	300 ml
	x1 Bomba de ar / Cleaning Blow Pump / Pompe à Air / Bomba de aire	-
	x6 Ponta Misturadora / Mixing Nozzle / Embout Mélangeur / Cánulas mezcladoras	-
	x1 Escovilhão de Limpeza / Cleaning Brush / Brosse circulaire / Escobilla	12 mm
	x6 Camisa de Nylon / Plastic Sleeves / Chemise de Nylon / Tamiz de nylon	M12 x 60
	x6 Camisa metálica / Internal Threaded Sockets / Chemise Métallique / Tamiz metálico	10 x 80
	x6 Varão roscado / Threaded rod / Tige filetée / Varillas roscadas	M10 x 90

### Classic

Classic / Classic / Classic



CÓDIGO CODE / CODE / CÓDIGO		DIMENSÕES SIZE / DIMENSIONS / MEDIDA
00400000002	x1 Malas de Bucha Química / Blow moulded site polypropilene / Valises de Cheville Chimique / Maleta de taco químico	500 x 360 x 120
	x1 Pistola para silicone Special / Caulking gun Special / Pistolet à Mastic Special / Pistola para silicona Special	300 ml
	x1 Bomba de ar / Cleaning Blow Pump / Pompe à Air / Bomba de aire	-
	x6 Ponta Misturadora / Mixing Nozzle / Embout Mélangeur / Cánulas mezcladoras	-
	x1 Escovilhão de Limpeza / Cleaning Brush / Brosse circulaire / Escobilla	12 mm
	x6 Camisa de Nylon / Plastic Sleeves / Chemise de Nylon / Tamiz de nylon	M12 x 60
	x6 Camisa metálica / Internal Threaded Sockets / Chemise Métallique / Tamiz metálico	10 x 80
	x6 Varão roscado / Threaded rod / Tige filetée / Varillas roscadas	M10 x 90

**BUCHAS**  
**NYLON**



*NYLON PLUG  
CHEVILLES PLASTIQUES  
ANCLAJES PLÁSTICOS*



# BUCHAS PLÁSTICAS

Nylon plug / Chevilles plastiques / Anclajes Plásticos

## PCL 518

### Bucha Poliamida eXtreme One PCL 518

eXtreme One Polyamide Plug PCL 518 / Cheville en Polyamide eXtreme One PCL 518 / Taco de Poliamida eXtreme One PCL 518



PA  
POLYAMIDE



#### DIÁMETRO ACONSELHADO

RECOMMENDED DIAMETER / DIAMÈTRE RECOMMANDÉE / DIÁMETRO RECOMENDADO

CÓDIGO CODE / CODE / CÓDIGO	DIMENSÕES SIZE / DIMENSIONS / MEDIDA	DIÁMETRO ACONSELHADO			EMBALAGEM QUANTITY / EMBALLAGE / EMBALAJE
		AGLOMERADO CHIPBOARD SCREW / VIS AGGLO / TORNILLOS AGLOMERADO	AUTO-ROSCANTES SELF TAPPING SCREWS / VIS À TÔLE / TORNILLOS AUTORROSCANTES	ROSCA MÉTRICA METRIC COARSE THREAD / FILETAGE MÉTRIQUE / ROSCA MÉTRICA	
051821060000	6 x 30	Ø4 - 5	Ø4 - 5	M4	500
051821080000	8 x 40	Ø4.5 - 6	Ø4.5 - 6	M5	200
051821100000	10 x 50	Ø6 - 8	Ø6 - 8	M6	100

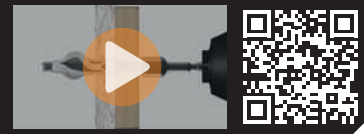

Quadros | Candeeiros | Cortinados | Interruptores elétricos | Caixa Correio | Pequenas prateleiras de parede | Rodapés | Caixilhas de alumínio | Sanitários

Frames | Lamps | Curtain rails | Electric switches | Mailboxes | Small wall shelves | Base boards | Aluminum frames | Sanitary ware  
Cadres | Lampes | Rideaux | Interrupteurs électriques | Boîtes aux lettres | Petites étagères de mur | Plinthes | Cadres en aluminium | Articles sanitaires  
Cuadros | Lámparas | Cortinajes | Interruptores eléctricos | Buzones | Estanterías de pared | Zócalos | Marcos de aluminio | Sanitarios





# EXTREME ONE<sup>®</sup>

## BUCHAS UNIVERSAL

UNIVERSAL PLUG / UNIVERSAL CHEVILLE / TACO UNIVERSAL

PECOL<sup>®</sup>

### COMPATÍVEL COM TODO O TIPO DE PARAFUSOS, MESMO QUE SEJAM DE ROSCA MÉTRICA

With any screws even with métric screws / Compatible avec tous les types de vis, même de filetage métrique / Compatible con todo tipo de tornillos, incluso con los de rosca métrica

### APLICÁVEL EM TODO O TIPO DE SUBSTRATOS, OCOS OU MACIÇOS

The plug is designed for both solid and hollow materials / Applicable en toutes les substrats, creuses ou pleines / Aplicable en todo tipo de materiales, huecos o macizos

### BUCHA PRODUZIDA EM POLIAMIDA DE ALTA QUALIDADE (NYLON PA 6.6)

Plug made of high quality polyamide (Nylon 6.6) / Cheville produite en polyamide de haute qualité (Nylon 6.6) / Taco fabricado en poliamida de alta calidad (Nylon 6.6)



#### ALHETAS ANTI-ROTAÇÃO DINÂMICAS

GARANTEM UMA PERFEITA EXPANSÃO DE  
ACORDO COM O SUBSTRATO

MAXI DYNAMIC ANTI-ROTATION WINGS: Differentiated expansion / AILETTES ANTI-ROTATION DYNAMICS, Assurent Une Expansion Perfect En Accord Avec Le Substrat / ALETAS ANTI-ROTACIÓN DINÁMICAS, garantizan una perfecta expansión acorde al material base



#### REDUZIDO BINÁRIO DE APERTO

MESMO NO MOMENTO DA  
EXPANSÃO

EVEN LOWER TORQUE NEEDED DURING  
EXPANSION / COUPLE ENCORE PLUS  
BASSE AU MOMENT DU VISSAGE / REDUCIDO PAR DE  
APRIETE, INCLUSO EN EL MOMENTO DE LA EXPANSIÓN



#### DESIGN INOVADOR

MÁXIMA EFICÁCIA EM TODO O  
TIPO DE SUBSTRATOS

INNOVATIVE DESIGN: Effectiveness in all kind of  
substrates / DESIGN INNOVANT, Efficacité Garantie  
Dans Toute Sorte De Substrats / DISEÑO INNOVADOR,  
eficacia garantizada en todo tipo de materiales



#### BORDO RETRÁTIL

GARANTINDO A PASSAGEM POR  
SUBSTRATOS INTERMÉDIOS

COLLAPSIBLE RIM: Through or  
pre-positioned fixing / BORD AMOVIBLE, de façon  
à assurer le passage pour substrats intermédiaires  
/ COLLARÍN FLEXIBLE, garantizando su paso por  
materiales intermedios

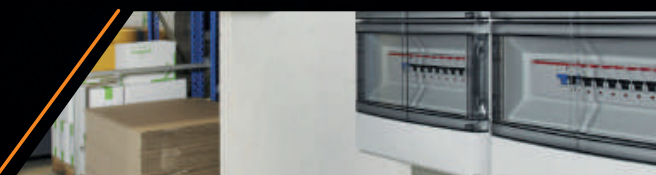
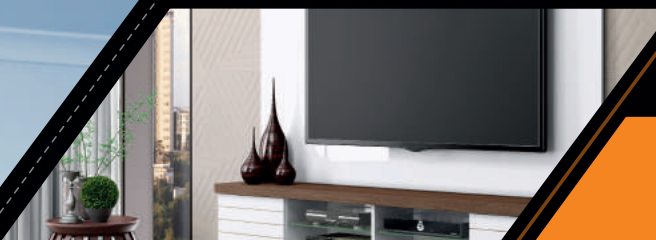



# BUCHAS PLÁSTICAS

Nylon plug / Chevilles plastiques / Anclajes Plásticos

## PCL 500

### Bucha Universal para Materiais de Construção Sólidos PCL 500

Universal Plug for Solid Building Materials PCL 500 / Cheville Universelle pour Matériaux de Construction Solides PCL 500 / Taco Universal para Materiales de Construcción Sólidos PCL 500

PCL 500

Com bordo / Rimmed / Avec collerette / Con collarín



CÓDIGO CODE / CODE / CÓDIGO	DIMENSÕES SIZE / DIMENSIONS / MEDIDA	Ø PARAFUSO SCREW SIZE / DIMENSION VIS / MEDIDA TORNILLO	EMBALAGEM QUANTITY / EMBALLAGE / EMBALAJE
05001105000	M5 x 25 Ø 5	2.5 - 4.0	1000
05001106000	M6 x 30 Ø 6	3.5 - 5.0	1000
05001108000	M8 x 40 Ø 8	4.5 - 6.0	500
05001110000	M10 x 50 Ø 10	6.0 - 8.0	200
05001112000	M12 x 60 Ø 12	8.0 - 10.0	100
05001114000	M14 x 75 Ø 14	10.0 - 12.0	50
05001114100	M14 x 100 Ø 14	10.0 - 12.0	50

CÓDIGO CODE / CODE / CÓDIGO	DIMENSÕES SIZE / DIMENSIONS / MEDIDA	Ø PARAFUSO SCREW SIZE / DIMENSION VIS / MEDIDA TORNILLO	CAIXA BOX / BOÎTE / CAJA
05001106002	M6 x 30 Ø 6	3.5 - 5.0	200
05001108003	M8 x 40 Ø 8	4.5 - 6.0	100
05001110002	M10 x 50 Ø 10	6.0 - 8.0	50

#### CAIXA MINI

Mini box  
Mini-boîte  
Mini caja



Aplicações elétricas | Quadros | Caixas de correio | Calhas técnicas | Aparelhos eletrônicos

Electrical application | Pictures | Mailboxes | Cable ducts | Electronic appliances

Applications électriques | Cadres | Boîtes aux lettres | Goulottes techniques | Appareils électroniques

Aplicaciones eléctricas | Cuadros | Buzones | Canaletas técnicas | Aparatos electrónicos

PCL 500

Sem bordo / Rimless / Sans collerette / Sin collarín



CÓDIGO CODE / CODE / CÓDIGO	DIMENSÕES SIZE / DIMENSIONS / MEDIDA	Ø PARAFUSO SCREW SIZE / DIMENSION VIS / MEDIDA TORNILLO	EMBALAGEM QUANTITY / EMBALLAGE / EMBALAJE
05000004000	M4 x 20 Ø 4	2.0 - 3.0	1000
05000005000	M5 x 25 Ø 5	2.5 - 4.0	1000
05000006000	M6 x 30 Ø 6	3.5 - 5.0	1000
05000007000	M7 x 30 Ø 7	4.0 - 5.5	1000
05000008000	M8 x 40 Ø 8	4.5 - 6.0	500
05000010000	M10 x 50 Ø 10	6.0 - 8.0	200
05000012000	M12 x 60 Ø 12	8.0 - 10.0	100
05000014000	M14 x 75 Ø 14	10.0 - 12.0	50
05000014100	M14 x 100 Ø 14	10.0 - 12.0	50
05000016000	M16 x 80 Ø 16	12.0 - 14.0	25

CÓDIGO CODE / CODE / CÓDIGO	DIMENSÕES SIZE / DIMENSIONS / MEDIDA	Ø PARAFUSO SCREW SIZE / DIMENSION VIS / MEDIDA TORNILLO	CAIXA BOX / BOÎTE / CAJA
05000006002	M6 x 30 Ø 6	3.5 - 5.0	200
05000008002	M8 x 40 Ø 8	4.5 - 6.0	100
05000010003	M10 x 50 Ø 10	6.0 - 8.0	50

#### CAIXA MINI

Mini box  
Mini-boîte  
Mini caja



Aplicações elétricas | Quadros | Caixas de correio | Calhas técnicas | Aparelhos eletrônicos

Electrical application | Pictures | Mailboxes | Cable ducts | Electronic appliances

Applications électriques | Cadres | Boîtes aux lettres | Goulottes techniques | Appareils électroniques

Aplicaciones eléctricas | Cuadros | Buzones | Canaletas técnicas | Aparatos electrónicos



## Bucha Universal para Materiais de Construção Sólidos PCL 502

Universal Plug for Solid Building Materials PCL 502 / Cheville Universelle pour Matériaux de Construction Solides PCL 502 / Taco Universal para Materiales de Construcción Sólidos PCL 502

# PCL 502

Con collarin / Avec collerette / Rimmed / Com bordo

PCL 502



CÓDIGO CODE / CODE / CÓDIGO	DIMENSÕES SIZE / DIMENSIONS / MEDIDA	Ø PARAFUSO SCREW SIZE / DIMENSION VIS / MEDIDA TORNILLO	EMBALAGEM QUANTITY / EMBALLAGE / EMBALAJE
050011050001	M5 x 25 Ø 5	2.5 - 4.0	1000
050011060001	M6 x 30 Ø 6	3.5 - 5.0	1000
050011080001	M8 x 40 Ø 8	4.5 - 6.0	500
050011100001	M10 x 50 Ø 10	6.0 - 8.0	200

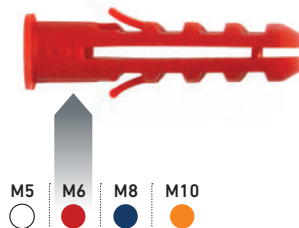

**Aplicações elétricas | Quadros | Caixas de correio | Calhas técnicas | Aparelhos eletrônicos**

Electrical application | Pictures | Mailboxes | Cable ducts | Electronic appliances  
Applications électriques | Cadres | Boîtes aux lettres | Goulottes techniques | Appareils électroniques  
Aplicaciones eléctricas | Cuadros | Buzones | Canaletas técnicas | Aparatos electrónicos

Sin collarin / Sans collerette / Rimless / Sem bordo

PCL 502



CÓDIGO CODE / CODE / CÓDIGO	DIMENSÕES SIZE / DIMENSIONS / MEDIDA	Ø PARAFUSO SCREW SIZE / DIMENSION VIS / MEDIDA TORNILLO	EMBALAGEM QUANTITY / EMBALLAGE / EMBALAJE
050010050001	M5 x 25 Ø 5	2.5 - 4.0	1000
050010060002	M6 x 30 Ø 6	3.5 - 5.0	1000
050010070001	M7 x 30 Ø 7	4.0 - 5.5	1000
050010080002	M8 x 40 Ø 8	4.5 - 6.0	500
050010100001	M10 x 50 Ø 10	6.0 - 8.0	200
050010120001	M12 x 60 Ø 12	8.0 - 10.0	100

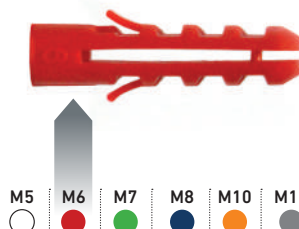

**Aplicações elétricas | Quadros | Caixas de correio | Calhas técnicas | Aparelhos eletrônicos**

Electrical application | Pictures | Mailboxes | Cable ducts | Electronic appliances  
Applications électriques | Cadres | Boîtes aux lettres | Goulottes techniques | Appareils électroniques  
Aplicaciones eléctricas | Cuadros | Buzones | Canaletas técnicas | Aparatos electrónicos

## Bucha Poliamida Tigre PCL 507

Solid Building Materials Polyamide Plug PCL 507 / Cheville en Polyamide Tigre PCL 507 / Taco de Poliamida Tigre PCL 507

# PCL 507



CÓDIGO CODE / CODE / CÓDIGO	DIMENSÕES SIZE / DIMENSIONS / MEDIDA	Ø PARAFUSO SCREW SIZE / DIMENSION VIS / MEDIDA TORNILLO	EMBALAGEM QUANTITY / EMBALLAGE / EMBALAJE
050021050001	5 x 25 Ø 5	4.0 x 30	500
050021060000	6 x 38 Ø 6	4.5 x 40	500
050021080000	8 x 40 Ø 8	5.0 x 50	200
050021100000	10 x 50 Ø 10	6.0 x 60	100
050021120000	12 x 60 Ø 12	10 x 70 / 12 x 70	25
050021140000	14 x 70 Ø 14	10 x 80 / 12 x 80	20



**Quadros | Candeeiros | Cortinados | Interruptores elétricos | Caixa Correio | Louças sanitárias | Pequenas prateleiras de parede | Rodapés**

Frames | Lamps | Curtain rails | Electric switchers | Mailboxes | Sanitary ware | Small wall shelves | Skirting  
Cadres | Lampes | Rideaux | Interrupteurs électriques | Boîtes aux lettres | Articles sanitaires | Petites étagères de mur | Plinthes  
Cuadros | Lámparas | Cortinajes | Interruptores eléctricos | Buzones | sanitários | Estanterías de pared | Zócalos

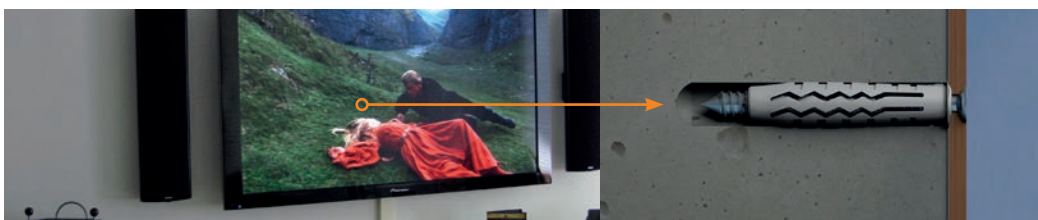



# BUCHAS PLÁSTICAS

Nylon plug / Chevilles plastiques / Anclajes Plásticos

## PCL 501

### Bucha Universal PCL 501

Universal Plug PCL 501 / Cheville Universelle PCL 501 / Taco Universal con collarín PCL 501

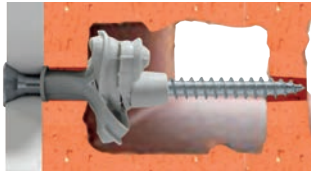

CÓDIGO CODE / CODE / CÓDIGO	DIMENSÕES SIZE / DIMENSIONS / MEDIDA	Ø PARAFUSO SCREW SIZE / DIMENSION VIS / MEDIDA TORNILLO	EMBALAGEM QUANTITY / EMBALLAGE / EMBALAJE
050100060000	6 x 38 Ø6	4 x 45	500
050100070000	7 x 36 Ø7	4,5 x 50	500
050100080000	8 x 51 Ø8	5 x 60	200
050100100000	10 x 61 Ø10	6 x 70	100
050100120000	12 x 71 Ø12	8 x 80	100



**Quadros | Candeeiros | Rodapés | Interruptores elétricos | Caixa Correio | Louças sanitárias | Pequenas prateleiras de parede**  
 Frames | Lamps | Skirting | Electric switchers | Mailboxes | Sanitary ware | Small wall shelves  
 Cadres | Lampes | Plinthes | Interrupteurs électriques | Boîtes aux lettres | Articles sanitaires | Petites étagères de mur  
 Cuadros | Lámparas | Zócalos | Interruptores eléctricos | Buzones | Sanitarios | Estanterías de pared

## PCL 503

### Bucha Taco PCL 503

Wall Plug PCL 503 / Cheville "Taco" PCL 503 / Taco Cilíndrico PCL 503

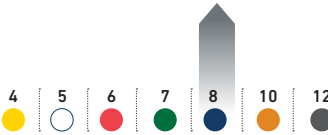

CÓDIGO CODE / CODE / CÓDIGO	DIMENSÕES SIZE / DIMENSIONS / MEDIDA	Ø PARAFUSO SCREW SIZE / DIMENSION VIS / MEDIDA TORNILLO	EMBALAGEM QUANTITY / EMBALLAGE / EMBALAJE
077823040000	4 x 25	2.5 - 3.0	500
077823050000	5 x 25	3.0 - 4.0	500
077823060000	6 x 35	3.5 - 5.0	500
077823070000	7 x 35	4.5 - 5.5	500
077823080000	8 x 35	5.0 - 6.0	500
077823100000	10 x 60	8.0	100
077823120000	12 x 60	10.0	100



**Aparelhos elétricos | Cortinas | Quadros | Caixas de correio | Conduitas | Calhas elétricas | Prateleiras para cargas leves**  
 Electric and electronic appliances | Skirting | Frames | Mailboxes | Cable ducts | Small and light shelves  
 Appareils électrique | Rideaux | Cadres | Boîtes aux lettres | Conduits | Goutottes électriques | Étagères pour charges légères  
 Aparatos eléctricos | Cortinas | Cuadros | Buzones | Conductos | Canaletas eléctricas | Estanterías para cargas leves

## PCL 623

### Bucha Poliamida p/ Gesso PCL 623

Concrete Polyamide Nail-it Anchor PCL 623 / Cheville Polyamide p/ Plâtre PCL 623 / Taco Poliamida p/ Yeso PCL 623

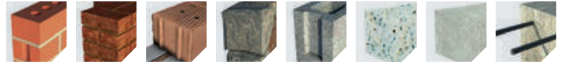

CÓDIGO CODE / CODE / CÓDIGO	DIMENSÕES SIZE / DIMENSIONS / MEDIDA	ESPESSURA A FIXAR FIXTURE THICKNESS / ÉPAISSEUR À FIXER / ESPESOR A FIJAR	EMBALAGEM QUANTITY / EMBALLAGE / EMBALAJE
062300060250	6 x 25	5	200
062300060380	6 x 38	9	250

CÓDIGO CODE / CODE / CÓDIGO	DIMENSÕES SIZE / DIMENSIONS / MEDIDA	ESPESSURA A FIXAR FIXTURE THICKNESS / ÉPAISSEUR À FIXER / ESPESOR A FIJAR	EMBALAGEM QUANTITY / EMBALLAGE / EMBALAJE
062300060250	6 x 25	5	1000



**Rodapés**  
 Base boards  
 Plinthes  
 Rodapiés





## Bucha Fixação Painel PCL 618/9

Insulation Fixing PCL 618/9 / Cheville Fixation Panneau PCL 618/9 / Taco Fijación Panel Aislante PCL 618/9

# PCL 618/9

Bucha em polipropileno adequada para a fixação de painéis de isolamento leves e pesados. O aperto da fixação às paredes do furo é efetuado através da extremidade rugosa da bucha. A bucha PCL 619 é apenas adequada para a aplicação do painel de isolamento não exposto à influência de forças de sucção do vento.

Impact-resistant propylene anchor for Insulation panels. It is suitable for fastening light and heavy insulation panels. The Tightening to the walls of the hole is made through the roughened end of the anchor. The anchor PCL 619 is only suitable for application of insulation panel not exposed to influence of wind suction forces.

Cheville en polypropylène adéquate pour la fixation de panneaux d'isolation légers et lourds. Le serrage de fixation aux parois du trou est effectué à l'aide de l'extrémité rugueuse de la cheville. La cheville PCL 619 est à peine adéquate pour application de panneau d'isolation non soumis à l'influence de forces de succion du vent.

Taco en polipropileno adecuado para la fijación de paneles de aislamiento leves y pesados. La fijación del taco a las paredes del agujero se efectúa a través de la extremidad rugosa del taco. El taco PCL 619 es adecuado exclusivamente para la aplicación del panel de aislamiento no expuesto a la influencia de fuerzas de succion del viento.

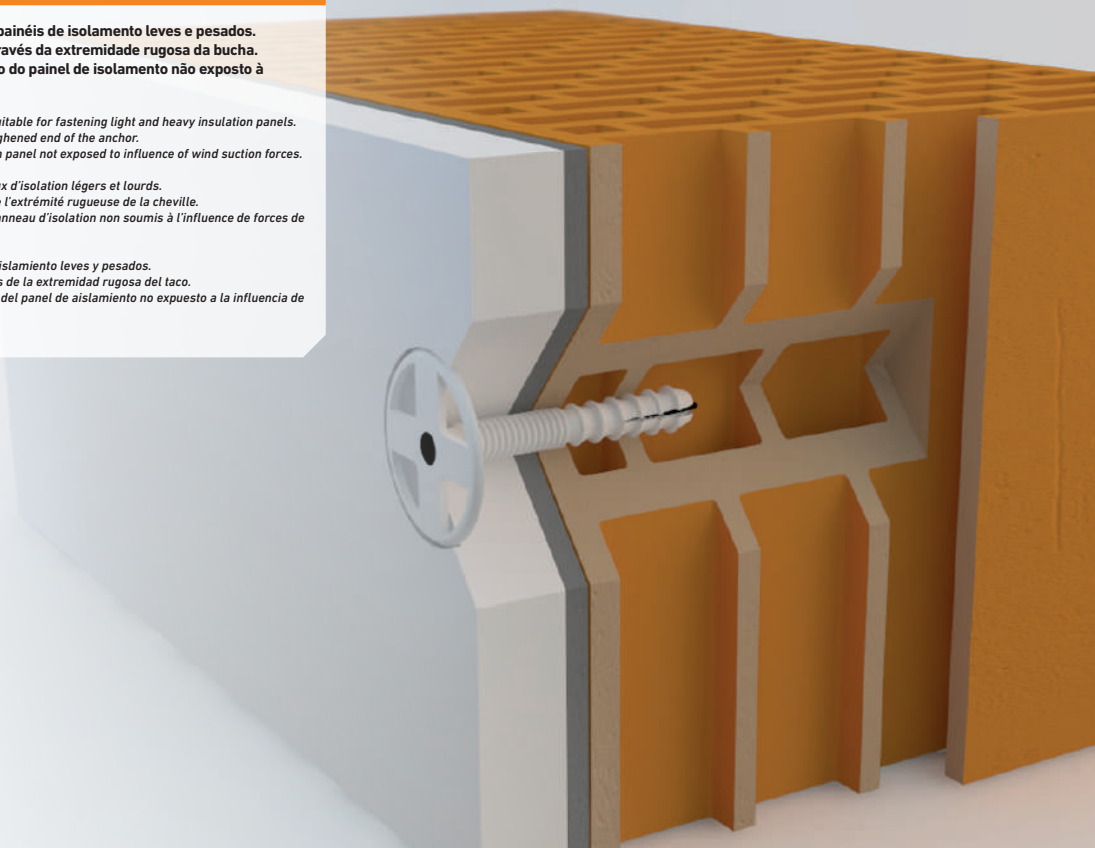

Taco con clavo / Cheville avec clou / Plug with nail / Bucha com prego

PCL 618



CÓDIGO CODE / CODE / CÓDIGO	DIMENSÕES SIZE / DIMENSIONS / MEDIDA	Ø ANILHA WASHER Ø / Ø RONDELLE / Ø ARANDELA	EMBALAGEM QUANTITY / EMBALLAGE / EMBALAJE
061800700000	10 x 70 Ø10	30	500
061800900000	10 x 90 Ø10	30	500
061800110000	10 x 110 Ø10	30	250
061800130000	10 x 130 Ø10	30	250



**Materiais de isolamento, tais como: Painéis de poliestireno | Painéis PU | Fibra de vidro | Lã de rocha**

Soft and pressure-resistant isolation material, such as: Polystyrene panels | PU panels | Fiberglass | Rock wool  
Matériaux d'isolation, tels que: Panneaux en polystyrène | Panneaux PU | Fibre de verre | Laine de roche  
Materiales de aislamiento, tales como: Paneles de poliestireno | Paneles PU | Fibra de vidrio | Lana de roca

Taco / Cheville / Plug / Bucha

PCL 619



CÓDIGO CODE / CODE / CÓDIGO	DIMENSÕES SIZE / DIMENSIONS / MEDIDA	Ø ANILHA WASHER Ø / Ø RONDELLE / Ø ARANDELA	EMBALAGEM QUANTITY / EMBALLAGE / EMBALAJE
061900700000	8 x 70 Ø8	50	500
061900900000	8 x 90 Ø8	50	250
061900110000	8 x 110 Ø8	50	50



**Materiais de isolamento, tais como: Painéis de poliestireno | Painéis PU | Fibra de vidro | Lã de rocha**

Soft and pressure-resistant isolation material, such as: Polystyrene panels | PU panels | Fiberglass | Rock wool  
Matériaux d'isolation, tels que: Panneaux en polystyrène | Panneaux PU | Fibre de verre | Laine de roche  
Materiales de aislamiento, tales como: Paneles de poliestireno | Paneles PU | Fibra de vidrio | Lana de roca



# BUCHAS PLÁSTICAS

Nylon plug / Chevilles plastiques / Anclajes Plásticos

## PCL 621/2/7

### Bucha TAP-TIP

Hammer in Polyamide Plug / Cheville à Frapper / Taco Clavable TAP-TIP

Bucha TAP-TIP produzida em poliamida de alta qualidade (PA 6.6), com parafuso prego em aço e com cabeça de embeber pré-montado, adequado para cargas leves. A bucha expande martelando ou aparafusando o parafuso prego. A bucha está equipada com bordo convexo que serve de batente e permite o bloqueio na espessura desejada.

*Reliable hammer-in-anchor (TAP-TIP) made of high quality polyamide (PA 6.6), with pre-mounted countersunk head steel nail screw suitable for light loads. The anchor expands by hammering or screwing the nail. The anchor is fitted with a convex stop rim that allows the blocking of the thickness desired.*

*Cheville à Frapper produite en polyamide de haute qualité (PA 6.6), avec clou vis en acier avec tête fraisée pré-monté, adéquate pour charges légères. La cheville s'épand en martelant ou vissant le clou vis. La cheville est équipée d'une collerette convexe qui sert de battant et permet le blocage dans l'épaisseur désirée.*

*Taco TAP-TIP fabricado en poliamida de alta calidad (PA 6.6), con tornillo clavo en acero y con cabeza atomada premontado, adecuado para cargas leves. El taco se expande martillando o atornillando el tornillo clavo. El taco tiene una cabeza con collarín que hace de tope fijando el material al espesor deseado.*



PCL 621



Z + PA  
ZINC + POLYAMIDE

PCL 621



Z + PA  
ZINC + POLYAMIDE

PCL 621



A2 + PA  
INOX + POLYAMIDE

PCL 622.1



Z + PA  
ZINC + POLYAMIDE

PCL 622



A2 + PA  
INOX + POLYAMIDE

PCL 627



Z + PA  
ZINC + POLYAMIDE

PCL 627



A2 + PA  
INOX + POLYAMIDE



Cabeza abombada y rosca arpón / Tête bombée et fil harpon / Pan head and harpoon thread / Cabeça queijo e rosca arpão  
Zincado / Zingú / Zinc plated / Zincado

PCL 621



CÓDIGO CODE / CODE / CÓDIGO	DIMENSÕES SIZE / DIMENSIONS / MEDIDA	ESPESSURA A FIXAR FIXTURE THICKNESS / ÉPAISSEUR À FIXER / ESPESOR A FIJAR	EMBALAGEM QUANTITY / EMBALLAGE / EMBALAJE
062101050300	5 x 30 Ø5	5	300
062101050400	5 x 40 Ø5	15	200
062101050500	5 x 50 Ø5	25	200
062101060400	6 x 40 Ø6	10	200
062101060500	6 x 50 Ø6	20	100
062101060600	6 x 60 Ø6	30	100

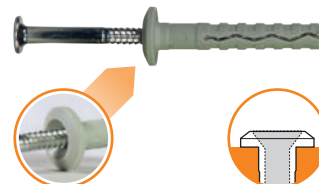

CÓDIGO CODE / CODE / CÓDIGO	DIMENSÕES SIZE / DIMENSIONS / MEDIDA	ESPESSURA A FIXAR FIXTURE THICKNESS / ÉPAISSEUR À FIXER / ESPESOR A FIJAR	EMBALAGEM QUANTITY / EMBALLAGE / EMBALAJE
062100050300	5 x 30 Ø5	5	300
062100050400	5 x 40 Ø5	15	200
062100050500	5 x 50 Ø5	25	200
062100060400	6 x 40 Ø6	10	200
062100060500	6 x 50 Ø6	20	100
062100060600	6 x 60 Ø6	30	100
062100080800	8 x 80 Ø8	40	100
062100081000	8 x 100 Ø8	60	100
062100081200	8 x 120 Ø8	80	100



Ligadores de parede | Rodapés | Componentes elétricos | Subestruturas | Prateleiras | Sinais | Louças sanitárias  
Wall connectors | Base boards | Electric components | Substructures | Shelves | Signs | Sanitary ware  
Prises de mur | Plinthes | Composants électrique | Substructure | Étagères | Signes | Articles sanitaires  
Conectores de pared | Rodapiés | Componentes eléctricos | Subestructuras | Estanterías | Rótulos | Sanitarios

Cabeza abombada y rosca arpón / Tête bombée et fil harpon / Pan head and harpoon thread / Cabeça queijo e rosca arpão  
Inoxidável A2 / Inoxydable A2 / Stainless steel A2 / Aço inox A2

PCL 621



CÓDIGO CODE / CODE / CÓDIGO	DIMENSÕES SIZE / DIMENSIONS / MEDIDA	ESPESSURA A FIXAR FIXTURE THICKNESS / ÉPAISSEUR À FIXER / ESPESOR A FIJAR	EMBALAGEM QUANTITY / EMBALLAGE / EMBALAJE
062161050300	5 x 30 Ø5	5	200
062161050400	5 x 40 Ø5	15	200
062161050500	5 x 50 Ø5	25	200
062161060400	6 x 40 Ø6	10	200
062161060500	6 x 50 Ø6	20	100
062161060600	6 x 60 Ø6	30	100



Ligadores de parede | Rodapés | Componentes elétricos | Subestruturas | Prateleiras | Sinais | Louças sanitárias  
Wall connectors | Base boards | Electric components | Substructures | Shelves | Signs | Sanitary ware  
Prises de mur | Plinthes | Composants électrique | Substructure | Étagères | Signes | Articles sanitaires  
Conectores de pared | Rodapiés | Componentes eléctricos | Subestructuras | Estanterías | Rótulos | Sanitarios

Cabeza avellanada y rosca arpón / Tête fraisée et fil harpon / Countersunk head and harpoon thread / Cabeça embeber e rosca arpão  
Zincado / Zingú / Zinc plated / Zincado

PCL 622.1



CÓDIGO CODE / CODE / CÓDIGO	DIMENSÕES SIZE / DIMENSIONS / MEDIDA	ESPESSURA A FIXAR FIXTURE THICKNESS / ÉPAISSEUR À FIXER / ESPESOR A FIJAR	EMBALAGEM QUANTITY / EMBALLAGE / EMBALAJE
062201050250	5 x 25 Ø5	5	500
062201050300	5 x 30 Ø5	5	500
062201050450	5 x 45 Ø5	15	500
062201060400	6 x 40 Ø6	10	200
062201060450	6 x 45 Ø6	15	200
062201060500	6 x 50 Ø6	20	200
062201060600	6 x 60 Ø6	30	200
062201060700	6 x 70 Ø6	35	200
062201060800	6 x 80 Ø6	50	100
062201080600	8 x 60 Ø8	20	100
062201080800	8 x 80 Ø8	40	100
062201081000	8 x 100 Ø8	60	100
062201081200	8 x 120 Ø8	80	100
062201081600	8 x 160 Ø8	100	50
062201100800	10 x 80 Ø10	30	100

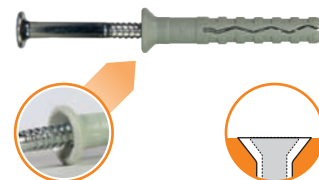

Ligadores de parede | Rodapés | Componentes elétricos | Subestruturas | Prateleiras | Sinais | Louças sanitárias  
Wall connectors | Base boards | Electric components | Substructures | Shelves | Signs | Sanitary ware  
Prises de mur | Plinthes | Composants électrique | Substructure | Étagères | Signes | Articles sanitaires  
Conectores de pared | Rodapiés | Componentes eléctricos | Subestructuras | Estanterías | Rótulos | Sanitarios



# BUCHAS PLÁSTICAS

Nylon plug / Chevilles plastiques / Anclajes Plásticos

PCL 622

**Cabeça embeber e rosca arpão / Countersunk head and harpoon thread / Tête fraisée et fil harpon / Cabeza avellanada y rosca arpón**  
Aço inox A2 / Stainless steel A2 / Inoxydable A2 / Inoxidable A2

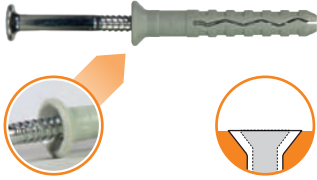
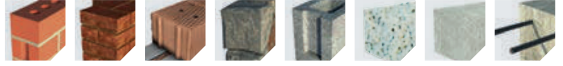

CÓDIGO CODE / CODE / CÓDIGO	DIMENSÕES SIZE / DIMENSIONS / MEDIDA	ESPESSURA A FIXAR FIXTURE THICKNESS / ÉPAISSEUR À FIXER / ESPESOR A FIJAR	EMBALAGEM QUANTITY / EMBALLAGE / EMBALAJE
062261050300	5 x 30 Ø5	5	300
062261050400	5 x 40 Ø5	15	200
062261050500	5 x 50 Ø5	25	200
062261060400	6 x 40 Ø6	10	200
062261060500	6 x 50 Ø6	20	100
062261060600	6 x 60 Ø6	30	100
062261060700	6 x 70 Ø6	35	100
062261060800	6 x 80 Ø6	50	100
062261080600	8 x 60 Ø8	20	100
062261080800	8 x 80 Ø8	40	100
062261081000	8 x 100 Ø8	60	100
062261081200	8 x 120 Ø8	80	50



**Ligadores de parede | Rodapés | Componentes elétricos | Subestruturas | Prateleiras | Sinais | Louças sanitárias**  
Wall connectors | Base boards | Electric components | Substructures | Shelves | Signs | Sanitary ware  
Prises de mur | Plinthes | Composants électrique | Substructure | Étagères | Signes | Articles sanitaires  
Conectores de pared | Rodapiés | Componentes eléctricos | Subestructuras | Estanterías | Rótulos | Sanitarios

PCL 627

**Cabeça Cilíndrica e rosca arpão / Cylindrical head and harpoon thread / Tête cylindrique et fil harpon / Cabeza cilíndrica y rosca arpón**  
Zincado / Zinc plated / Zingué / Zincado

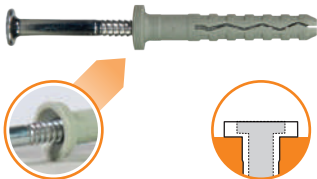

CÓDIGO CODE / CODE / CÓDIGO	DIMENSÕES SIZE / DIMENSIONS / MEDIDA	ESPESSURA A FIXAR FIXTURE THICKNESS / ÉPAISSEUR À FIXER / ESPESOR A FIJAR	EMBALAGEM QUANTITY / EMBALLAGE / EMBALAJE
062700050300	5 x 30 Ø5	5	300
062700050400	5 x 40 Ø5	15	200
062700050500	5 x 50 Ø5	25	200
062700060400	6 x 40 Ø6	10	200
062700060500	6 x 50 Ø6	20	100
062700060600	6 x 60 Ø6	30	100
062700080600	8 x 60 Ø8	20	150
062700080800	8 x 80 Ø8	40	150
062700081000	8 x 100 Ø8	60	100
062700081200	8 x 120 Ø8	80	100



**Ligadores de parede | Rodapés | Componentes elétricos | Subestruturas | Prateleiras | Sinais | Louças sanitárias**  
Wall connectors | Base boards | Electric components | Substructures | Shelves | Signs | Sanitary ware  
Prises de mur | Plinthes | Composants électrique | Substructure | Étagères | Signes | Articles sanitaires  
Conectores de pared | Rodapiés | Componentes eléctricos | Subestructuras | Estanterías | Rótulos | Sanitarios

PCL 627

**Cabeça Cilíndrica e rosca arpão / Cylindrical head and harpoon thread / Tête cylindrique et fil harpon / Cabeza cilíndrica y rosca arpón**  
Aço inox A2 / Stainless steel A2 / Inoxydable A2 / Inoxidable A2

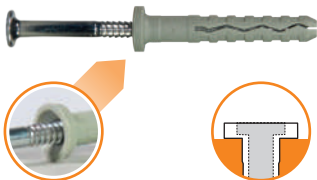

CÓDIGO CODE / CODE / CÓDIGO	DIMENSÕES SIZE / DIMENSIONS / MEDIDA	ESPESSURA A FIXAR FIXTURE THICKNESS / ÉPAISSEUR À FIXER / ESPESOR A FIJAR	EMBALAGEM QUANTITY / EMBALLAGE / EMBALAJE
062761060400	6 x 40 Ø6	10	200
062761060500	6 x 50 Ø6	20	100
062761060600	6 x 60 Ø6	30	100
062761060700	6 x 70 Ø6	35	100
062761080600	8 x 60 Ø8	20	100
062761080800	8 x 80 Ø8	40	100
062761081000	8 x 100 Ø8	60	100



**Ligadores de parede | Rodapés | Componentes elétricos | Subestruturas | Prateleiras | Sinais | Louças sanitárias**  
Wall connectors | Base boards | Electric components | Substructures | Shelves | Signs | Sanitary ware  
Prises de mur | Plinthes | Composants électrique | Substructure | Étagères | Signes | Articles sanitaires  
Conectores de pared | Rodapiés | Componentes eléctricos | Subestructuras | Estanterías | Rótulos | Sanitarios

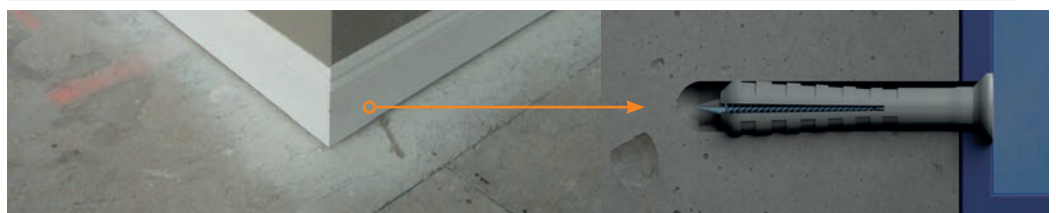





## Bucha Universal de Alto Rendimento PCL 123/4

Universal high performance knotting plug PCL 123/4 / Cheville universel de haute performance PCL 123/4 / Taco anudable universal de alto rendimiento PCL 123/4

# PCL 123/4

A bucha universal de alto rendimento PCL 123/4 é produzida em poliamida de alta qualidade (PA6.6) e é ideal tanto para materiais maciços como para ocós. É indicada para cargas médias-altas. O design da bucha garante a expansão nos dois tipos de substratos, sólidos e ocós. Em materiais ocós a bucha deforma-se em nó garantindo uma ancoragem perfeita. É a bucha ideal para quando se desconhece a composição do substrato onde se pretende realizar a ancoragem.

*PCL 123/4 plug is designed for both solid and hollow materials, made of high quality polyamide (PA6). Specially recommended for medium-high loads. Expansion guaranteed in both solid and hollow materials, knotting in hollow ones. Ideal when base material composition is unknown.*

*La cheville universel de haute performance PCL 123/4 est produit en polyamide de haute qualité (PA6) idéal pour les matières solides telles que des matériaux creux. Il est adapté pour les charges moyenne-haute. La conception de la cheville assure son expansion autant dans les substrats solides que dans les substrats creux. Dans les matériaux creux la douille se déforme et fait un nœud pour assurer une ancrage parfaite. C'est la cheville idéal pour quand la composition du substrat à ancrer n'est pas connu.*

*El taco PCL 123/4 tanto para materiales sólidos como huecos está fabricado en poliamida de alta calidad (PA6). Ideal para cargas medias-altas. Expansión garantizada tanto en materiales sólidos como en huecos al anudarse en estos últimos. Ideal cuando se desconoce la naturaleza del material base.*



PCL 123



CÓDIGO CODE / CODE / CÓDIGO	DIMENSÕES SIZE / DIMENSIONS / MEDIDA	ESPESSURA A FIXAR FIXTURE THICKNESS / ÉPAISSEUR À FIXER / ESPESOR A FIJAR	EMBALAGEM QUANTITY / EMBALLAGE / EMBALAJE
012300080800	8 x 80 Ø8	10	50
012300081000	8 x 100 Ø8	30	50
012300081200	8 x 120 Ø8	50	50
012300100800	10 x 80 Ø10	10	50
012300101000	10 x 100 Ø10	30	50
012300101200	10 x 120 Ø10	50	50
012300101400	10 x 140 Ø10	70	50
012300101600	10 x 160 Ø10	90	50
012300102000	10 x 200 Ø10	130	50
012300102300	10 x 230 Ø10	160	50



**Estruturas pesadas | Gradeamentos | Portões | Caixilharia de portas e janelas | Mobiliário urbano | Escadas | Maquinaria**  
Heavy structure works | Railing | Gates | Doorframes and windows | Urban Furniture | Stairs | Machines  
Structures lourdes | Grillages | Portails | Cadres de portes et fenêtres | Mobilier urbain | Escaliers | Machinerie  
Estructuras pesadas | Enrejados | Portones | Marcos de puertas y ventanas | Mobiliario urbano | Escaleras | Maquinaria

PCL 124



CÓDIGO CODE / CODE / CÓDIGO	DIMENSÕES SIZE / DIMENSIONS / MEDIDA	ESPESSURA A FIXAR FIXTURE THICKNESS / ÉPAISSEUR À FIXER / ESPESOR A FIJAR	EMBALAGEM QUANTITY / EMBALLAGE / EMBALAJE
012400080800	8 x 80 Ø8	10	50
012400081000	8 x 100 Ø8	30	50
012400100850	10 x 85 Ø10	15	50
012400101000	10 x 100 Ø10	30	50
012400101350	10 x 135 Ø10	65	50



**Estruturas pesadas | Gradeamentos | Portões | Caixilharia de portas e janelas | Mobiliário doméstico e urbano | Escadas | Maquinaria**  
Heavy structure works | Railing | Gates | Doorframes and windows | Home and Urban Furniture | Stairs | Machines  
Structures lourdes | Grillages | Portails | Cadres de portes et fenêtres | Maison et mobilier urbain | Escaliers | Machinerie  
Estructuras pesadas | Enrejados | Portones | Marcos de puertas y ventanas | Mobiliario doméstico y urbano | Escaleras | Maquinaria



**O SEU FORNECEDOR DE SEMPRE,  
ONDE ESTIVER!**

*/ Your ever-ready supplier, wherever you are! / Votre fournisseur de toujours, où que vous soyez! / Su proveedor de siempre, donde esté!*

[HTTP://STORE.PECOL.PT/](http://store.pecol.pt/)

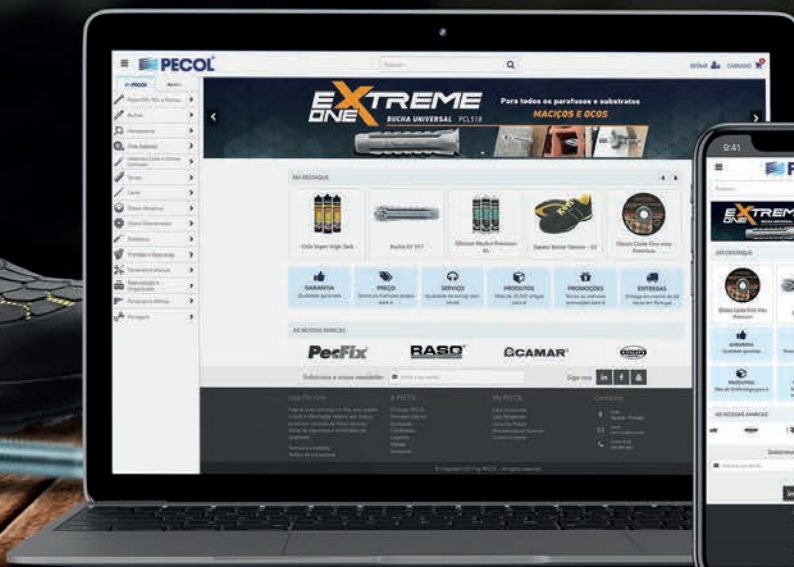



# ABRACAÇADEIRAS PLÁSTICAS

*CABLE TIES  
COLLIERS EN POLYAMIDE  
ABRAZADERAS POLIAMIDA*



# ABRAÇADEIRAS POLIAMIDA

Cable Ties / Colliers en Polyamide / Abrazaderas Poliamida

## PCL 7000 Abraçadeira de Poliamida

Nylon Cable Tie / Collier de Serrage / Bridas de Nylon

PCL 7000

Preta / Black / Noir / Negra

PA  
POLYAMIDE



CÓDIGO CODE / CODE / CÓDIGO	DIMENSÕES SIZE / DIMENSIONS / MEDIDA	EMBALAGEM QUANTITY / EMBALLAGE / EMBALAGEM
700001250750	2,5 x 75	100
700001251000	2,5 x 100	100
700001251300	2,5 x 130	100
700001261350	2,6 x 135	100
70000126160	2,6 x 160	100
700001262000	2,6 x 200	100
700001361400	3,6 x 140	100
700001362000	3,6 x 200	100
700001362900	3,6 x 280	100
700001363000	3,6 x 300	100
700001481800	4,8 x 180	100
700001482000	4,8 x 200	100
700001482800	4,8 x 280	100
700001483000	4,8 x 300	100
700001483600	4,8 x 360	100
700001484500	4,8 x 450	100
700001485000	4,8 x 500	100
700001762000	7,6 x 200	100
700001783000	7,8 x 300	100
700001783650	7,8 x 365	100
700001784500	7,8 x 450	100
700001787500	7,8 x 750	100
700001906100	9,0 x 610	100
700001097800	9,0 x 780	100



RoHS



**Cabos, Mangueiras, Outdoors, etc**  
Cables, Hoses, Outdoors, etc  
Câbles, Tuyaux, Panneaux d'affichage, etcx  
Cables, Mangueras, Puertas exteriores, etc

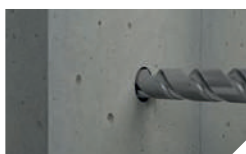



Transparente / Transparent / Transparent / Transparente

PCL 7000



CÓDIGO CODE / CODE / CÓDIGO	DIMENSÕES SIZE / DIMENSIONS / MEDIDA	EMBALAGEM QUANTITY / EMBALLAGE / EMBALAGEM
700000250750	2,5 x 75	100
700000251000	2,5 x 100	100
700000261350	2,6 x 135	100
700000261600	2,6 x 160	100
700000262000	2,6 x 200	100
700000361400	3,6 x 140	100
700000362000	3,6 x 200	100
700000362800	3,6 x 280	100
700000363000	3,6 x 300	100
700000481800	4,8 x 180	100
700000482000	4,8 x 200	100
700000482800	4,8 x 280	100
700000483000	4,8 x 300	100
700000483600	4,8 x 360	100
700000484500	4,8 x 450	100
700000485000	4,8 x 500	100
700000762000	7,6 x 200	100
700000781800	7,8 x 180	100
700000783000	7,8 x 300	100
700000783650	7,8 x 365	100
700000784500	7,8 x 450	100
700000787500	7,8 x 750	100
700000906100	9,0 x 610	100
700012610000	12,6 x 1000	100



RoHS



**Cabos, Mangueiras, Outdoors, etc**  
Cables, Hoses, Outdoors, etc  
Câbles, Tuyaux, Panneaux d'affichage, etcx  
Cables, Mangueras, Puertas exteriores, etc

Verde / Vert / Green / Verde

PCL 7000



CÓDIGO CODE / CODE / CÓDIGO	DIMENSÕES SIZE / DIMENSIONS / MEDIDA	EMBALAGEM QUANTITY / EMBALLAGE / EMBALAGEM
700002251000	2,5 x 100	100
700002361400	3,6 x 140	100
700002362000	3,6 x 200	100
700002483000	4,8 x 300	100
700002483600	4,8 x 360	100



RoHS



**Cabos, Mangueiras, Outdoors, Agricultura, etc**  
Cables, Hoses, Outdoors, Agriculture, etc  
Câbles, Tuyaux, Panneaux d'affichage, Agriculture, etc  
Cables, Mangueras, Puertas exteriores, Agricultura, etc



# ABRAÇADEIRAS POLIAMIDA

Cable Ties / Colliers en Polyamide / Abrazaderas Poliamida

## PCL 7001 Bucha para Abraçadeira de Poliamida

Plug Cable Tie Support / Taquet Collier / Taco para Bridas

PCL 7001

Preta / Black / Noir / Negra



PA  
POLYAMIDE



CÓDIGO CODE / CODE / CÓDIGO	DIMENSÕES SIZE / DIMENSIONS / MEDIDA	EMBALAGEM QUANTITY / EMBALLAGE / EMBALAGEM
70010000001	M6	100

PCL 7001

Branca / White / Blanc / Blanca

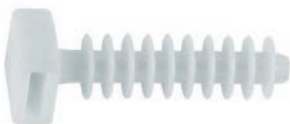

PA  
POLYAMIDE



CÓDIGO CODE / CODE / CÓDIGO	DIMENSÕES SIZE / DIMENSIONS / MEDIDA	EMBALAGEM QUANTITY / EMBALLAGE / EMBALAGEM
70010000002	M6	100



**SERVIÇO FÁCIL**  
Easy Service / Service facile / Fácil serviço

**FÁCIL DE CARREGAR**  
Easy to Load / Facile à Charger / Fácil de Re-Carregar

## CAIXA EXPOSITORA DE ABRAÇADEIRAS

Clamps Display Box / Caisse d'Exposition de Colliers / Caja Expositor de Bridas



## Abraçadeira Pressão c/ Pré-Rosca M6

Pressure nylon pipe clip, with pre-thread M6 / Collier de Pression avec Préfilet M6 / Abrazadera a presión, con pre-rosca M6

# PCL 118

Gris / Gris / Grey / Cinza

PCL 118

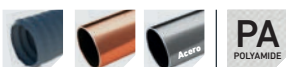

CÓDIGO CODE / CODE / CÓDIGO	DIMENSÕES SIZE / DIMENSIONS / MEDIDA	ØD(MM)	EMBALAGEM QUANTITY / EMBALLAGE / EMBALAGEM
011800120000	12	12	100
011800150000	15-18	15-18	100
011800200000	20-22	20-22	100
011800250000	25-28	25-28	100
011800320000	32-35	32-35	25
011800400000	40	40	25



**Cabos, Mangueiras, Outdoors, etc**  
Cables, Hoses, Outdoors, etc  
Câbles, Tuyaux, Panneaux d'affichage, etcx  
Cables, Mangueras, Puertas exteriores, etc



Libre de Halogéneos  
Halogen free  
Sans halogène  
Libre de halógenos

## Clip Nylon Simples c/ Casquilho Latão M6

Simple nylon pipe clip (polyamide 6.6) with M6 threaded brass insert / Collier clip simple nylon (polyamide 6.6) avec crou de laiton M6 / Abrazadera simple de nylon (poliamida 6.6) con casquillo de latón M6

# PCL 119

Poliamida / Polyamide / Polyamide / Poliamida

PCL 119

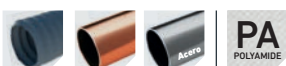

CÓDIGO CODE / CODE / CÓDIGO	DIMENSÕES SIZE / DIMENSIONS / MEDIDA	ØD(MM)	EMBALAGEM QUANTITY / EMBALLAGE / EMBALAGEM
011900120000	12	12	100
011900140000	14-15	14-16	100
011900160000	16-18	16-18	100
011900200000	20-22	20-22	100
011900280000	28	28	50



**Cabos, Mangueiras, Outdoors, etc**  
Cables, Hoses, Outdoors, etc  
Câbles, Tuyaux, Panneaux d'affichage, etcx  
Cables, Mangueras, Puertas exteriores, etc



Libre de Halogéneos  
Halogen free  
Sans halogène  
Libre de halógenos

## Clip Nylon Duplo c/ Casquilho Latão M6

Double nylon pipe clip (polyamide 6.6), with M6 threaded brass insert / Collier clip double nylon (polyamide 6.6) avec crou de laiton M6 / Abrazadera doble de nylon (poliamida 6.6) con casquillo de latón M6

# PCL 121

Poliamida / Polyamide / Polyamide / Poliamida

PCL 121

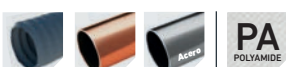

CÓDIGO CODE / CODE / CÓDIGO	DIMENSÕES SIZE / DIMENSIONS / MEDIDA	ØD(MM)	EMBALAGEM QUANTITY / EMBALLAGE / EMBALAGEM
012100120000	12	12	100
012100140000	14-15	14-16	100
012100160000	16-18	16-18	100
012100200000	20-22	20-22	100
012100280000	28	28	50



**Cabos, Mangueiras, Outdoors, etc**  
Cables, Hoses, Outdoors, etc  
Câbles, Tuyaux, Panneaux d'affichage, etcx  
Cables, Mangueras, Puertas exteriores, etc



Libre de Halogéneos  
Halogen free  
Sans halogène  
Libre de halógenos



# ABRAÇADEIRAS POLIAMIDA

Cable Ties / Colliers en Polyamide / Abrazaderas Poliamida

## PCL 126

### Abraçadeira guia simples com pré-rosca M6 Cinza

Closed nylon pipe clip, with pre-thread M6. Grey / Collier guide avec préfilet M6. Gris / Abrazadera guía gris simple con pre-rosca M6

PCL 126

Polipropileno / Polypropylene / Polypropylène / Polipropileno



Libre de Halogéneos  
Halogen free  
Sans halogène  
Libre de halógenos

CÓDIGO CODE / CODE / CÓDIGO	DIMENSÕES SIZE / DIMENSIONS / MEDIDA	ØD(MM)	EMBALAGEM QUANTITY / EMBALLAGE / EMBALAGEM
012600120000	12	12	100
012600150000	15	15	100
012600180000	18	18	100
012600200000	20	20	100
012600220000	22	22	100
012600250000	25	25	50
012600280000	28	28	50
012600320000	32	32	50
012600400000	40	40	50
012600500000	50	50	50



Cabos, Mangueiras, Outdoors, etc  
Cables, Hoses, Outdoors, etc  
Câbles, Tuyaux, Panneaux d'affichage, etc  
Cables, Mangueras, Puertas exteriores, etc

## PCL 145

### Clip simples fixação tubo

Plug Cable Tie / Clip / Taco para Fijación de Tubo

PCL 145

Poliamida / Polyamide / Polyamide / Poliamida



CÓDIGO CODE / CODE / CÓDIGO	DIMENSÕES SIZE / DIMENSIONS / MEDIDA	ØD(MM)	EMBALAGEM QUANTITY / EMBALLAGE / EMBALAGEM
014500160000	16	3/8"	100
014500180000	18	-	100
014500200000	20	1/2"	100
014500220000	22	-	100
014500250000	25	3/4"	100

CÓDIGO CODE / CODE / CÓDIGO	DIMENSÕES SIZE / DIMENSIONS / MEDIDA	ØD(MM)	EMBALAGEM QUANTITY / EMBALLAGE / EMBALAGEM
014500160001	16	3/8"	100
014500200001	20	1/2"	100
014500250001	25	3/4"	100



Cabos, Mangueiras, Outdoors, etc  
Cables, Hoses, Outdoors, etc  
Câbles, Tuyaux, Panneaux d'affichage, etc  
Cables, Mangueras, Puertas exteriores, etc



Absorção dilatação  
Dilation absorption  
Résistance aux UV  
Absorción dilatación



Libre de Halogéneos  
Halogen free  
Sans halogène  
Libre de halógenos



# ABRAÇADEIRAS METÁLICAS

METALLIC CABLE TIES  
COLLIERS MÉTALIQUES  
ABRAZADERAS METÁLICAS





# ABRAÇADEIRAS METÁLICAS

Metallic Cable Ties / Colliers Métalliques / Abrazaderas Metálicas

## PCL 3017 Abraçadeira Meb

Hose Clamp / Collier sansfin / Abrazadera Sin-Fin

PCL 3017 MEB 9

Zincado / Zinc plated / Zingué / Zincado



CÓDIGO CODE / CODE / CÓDIGO	DIMENSÕES SIZE / DIMENSIONS / MEDIDA	APERTO GRIP / POIGNÉE / APERTO	EMBALAGEM QUANTITY / EMBALLAGE / EMBALAJE
301712090100	M10 x 9	10-17	100
301712090120	M12 x 9	12-20	100
301712090150	M15 x 9	15-25	100
301712090200	M20 x 9	20-32	50
301712090250	M25 x 9	25-40	50
301712090320	M32 x 9	32-50	50
301712090400	M40 x 9	40-60	50
301712090500	M50 x 9	50-70	10
301712090580	M58 x 9	58-78	10
301712090600	M60 x 9	60-80	10
301712090700	M70 x 9	70-90	10
301712090800	M80 x 9	80-100	10
301712090900	M90 x 9	90-110	10
301712091000	M100 x 9	100-120	10
301712091100	M110 x 9	110-130	10
301712091300	M130 x 9	150-150	10
301712091600	M160 x 9	160-180	10



Mangueiras  
Hoses  
Tuyaux d'arrosage  
Mangueras

PCL 3017 MEB 9

Aço inox A2 / Stainless steel A2 / Inoxydable A2 / Inoxidable A2



CÓDIGO CODE / CODE / CÓDIGO	DIMENSÕES SIZE / DIMENSIONS / MEDIDA	APERTO GRIP / POIGNÉE / APERTO	EMBALAGEM QUANTITY / EMBALLAGE / EMBALAJE
301761090100	M10 x 9	10-17	100
301761090120	M12 x 9	12-20	100
301761090150	M15 x 9	15-25	100
301761090200	M20 x 9	20-32	50
301761090250	M25 x 9	25-40	50
301761090320	M32 x 9	32-50	50
301761090400	M40 x 9	40-60	50
301761090500	M50 x 9	50-70	10
301761090600	M60 x 9	60-80	10
301761090700	M70 x 9	70-90	10
301761090800	M80 x 9	80-100	10
301761090900	M90 x 9	90-110	10



Mangueiras  
Hoses  
Tuyaux d'arrosage  
Mangueras

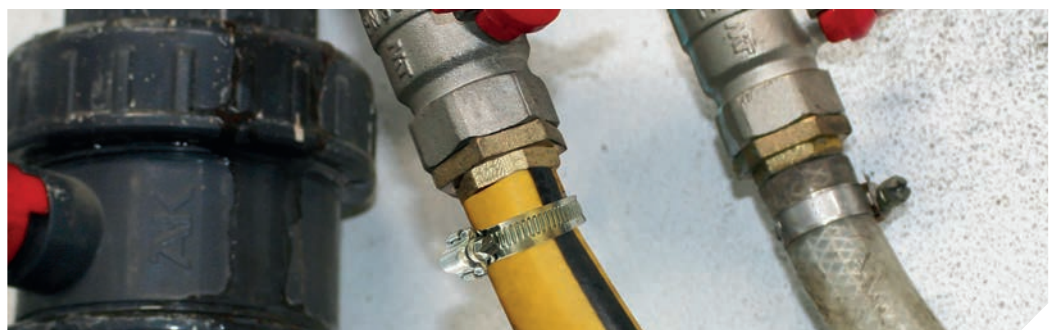

## Abraçadeira de Espigão com Parafuso Soldado

Abrazadera de Espigón c/ Tornillo Soldado / Drain pipe clamp with welded screw / Colliers à pointe a/ vis soudée

# PCL 102

Zincado / Zingué / Zinc Plated / Zincado

PCL 102



CÓDIGO CODE / CODE / CÓDIGO	DIMENSÕES (mm) SIZE / DIMENSIONS / MEDIDA	DIMENSÕES" SIZE / DIMENSIONS / MEDIDA	EMBALAGEM QUANTITY / EMBALLAGE / EMBALAJE
010212190000	25	3/4"	50
010212250000	32	1"	60
010212320000	40	1 1/4"	50
010212380000	50	1 1/2"	50
010212500000	63	2"	50
010212630000	75	2 1/2"	50
010212750000	90	3"	50
010212900000	-	3 1/2"	50
010212100000	110	4"	50
010212114000	115	4 1/2"	50
010212127000	125	5"	10



**Aço e tubos de drenagem de PVC**  
Steel and PVC drain tubes  
Acier et tubes de drainage en PVC  
Acero y tubos de drenaje de PVC



## Abraçadeira Isofónica M8+M10

Abrazadera Isofónica M8+M10 / Collier isophonique M8+M10 / Isophononic pipe clamp M8+M10

# PCL 104

Zincado / Zingué / Zinc Plated / Zincado

PCL 104



CÓDIGO CODE / CODE / CÓDIGO	DIMENSÕES (mm) SIZE / DIMENSIONS / MEDIDA	DIMENSÕES" SIZE / DIMENSIONS / MEDIDA	EMBALAGEM QUANTITY / EMBALLAGE / EMBALAJE
010413022000	20-25	1/2	100
010413028000	26-30	3/4	100
010413035000	32-36	1	50
010413040000	38-42	1 1/4	50
010413048000	47-51	1 1/2	50
010413054000	53-58	2 3/32 - 2 9/32	50
010413060000	60-64	2	25
010413070000	68-72	2 43/64 - 2 53/64	25
010413075000	75-80	2 1/2	25
010413083000	81-86	3 3/16 - 3 25/64	25
010413090000	87-92	3	25
010413100000	99-105	3 57/64 - 4 9/64	25
010413110000	107-112	4	25
010413115000	113-118	4	25
010413125000	125-130	5	25
010413133000	132-137	5 13/64 - 5 25/64	25
010413140000	130-142	5	25
010413150000	148-152	5 53/64 - 5 63/64	25
010413160000	159-166	6 17/64 - 6 17/32	25
010413180000	179-184	6	25
010413200000	199-210	7 53/64 - 8 17/64	25
010413220000	215-225	8 15/32 - 8 55/64	25
010413250000	249-254	9 51/64 - 10	25
010413300000	299-304	11 49/64 - 11 31/32	25
010413350000	349-354	-	25



**Instalações de cargas pesadas | Instalações mecânicas | Linhas industriais**  
Heavy duty installations | Mechanical installations | Process and control lines  
Installations de charges lourdes | Installations mécaniques | Lignes industrielles  
Instalaciones de cargas pesadas | Instalaciones mecánicas | Líneas industriales

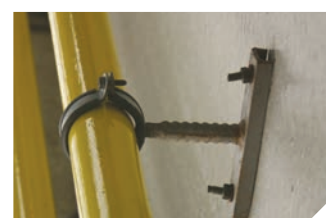



# ABRAÇADEIRAS METÁLICAS

Metallic Cable Ties / Colliers Métalliques / Abrazaderas Metálicas

## PCL 108

### Abrazadera Isofónica M6

Collier isophonique M6 / Isophonnic pipe clamp M6 / Abraçadeira Isofónica M6

PCL 108

Bicromatado / Yellow Zinc Plated / Bichomaté / Passivado Amarelo

PA  
YELLOW



CÓDIGO CODE / CODE / CÓDIGO	MEDIDA (mm) SIZE / DIMENSIONS / DIMENSÕES	MEDIDA* SIZE / DIMENSIONS / DIMENSÕES	EMBALAJE QUANTITY / EMBALLAGE / EMBALAGEM
010813010000	10	25/64	100
010813012000	12	1/4	100
010813014000	14	35/64	100
010813016000	16	3/8	100
010813018000	18	45/64	100
010813020000	20	25/32	100
010813022000	22	1/2	100
010813026000	26	3/4	100
010813028000	28	1 7/64	100
010813032000	32	1 17/64	50
010813035000	35	1	50
010813042000	42	1 1/4	50
010813048000	48	1 1/2	50
010813054000	54	2 1/8	50
010813060000	60	2	50



Instalaciones de cargas pesadas | Instalaciones mecánicas | Líneas industriales

Heavy duty installations | Mechanical installations | Process and control lines  
Installations de charges lourdes | Installations mécaniques | Lignes industrielles  
Instalações de cargas pesadas | Instalações mecânicas | Linhas industriais

## PCL 107

### Abrazadera Doble Isofónica M6

Collier double isophonique M6 / Double isophonnic pipe clamp M6 / Abraçadeira Isofónica Dupla M6

PCL 107

Bicromatado / Yellow Zinc Plated / Bichomaté / Passivado Amarelo

PA  
YELLOW



CÓDIGO CODE / CODE / CÓDIGO	MEDIDA (mm) SIZE / DIMENSIONS / DIMENSÕES	MEDIDA* SIZE / DIMENSIONS / DIMENSÕES	EMBALAJE QUANTITY / EMBALLAGE / EMBALAGEM
010713012000	1/4	12	50
010713015000	3/8	15	50
010713018000	1/2	18	50
010713022000	7/8 - 1	22	50
010713026000	1 1/32 - 1 7/64	26	50



Instalaciones de cargas pesadas | Instalaciones mecánicas | Líneas industriales

Heavy duty installations | Mechanical installations | Process and control lines  
Installations de charges lourdes | Installations mécaniques | Lignes industrielles  
Instalações de cargas pesadas | Instalações mecânicas | Linhas industriais



## Abraçadeira Simples M6 **PCL 105**

Pipe clamp M6 / Collier simple M6/ Abrazadera M6

Bricomatado / Bichomaté / Yellow Zinc Plated / Passivado Amarelo

PCL 105



CÓDIGO CODE / CODE / CÓDIGO	DIMENSÕES (mm) SIZE / DIMENSIONS / MEDIDA	DIMENSÕES" SIZE / DIMENSIONS / MEDIDA	EMBALAGEM QUANTITY / EMBALLAGE / EMBALAJE
010513012000	12	-	100
010513014000	14	1/4	100
010513015000	15	-	100
010513016000	16	-	100
010513018000	18	3/8	100
010513020000	20	-	100
010513022000	22	1/2	100
010513024000	24	-	100
010513026000	26	3/4	100
010513028000	28	-	100
010513030000	30	-	100
010513032000	32	-	50
010513035000	35	-	50
010513042000	42	1 1/2	50
010513047000	47	1 1/2	50
010513050000	50	-	50
010513054000	54	-	50



**Tubos Metálicos**  
Light Metal Tubes  
Tubes Métalliques  
Tubos Metálicos

## Abraçadeira Dupla M6 **PCL 106**

Double pipe clamp M6 / Collier double M6/ Abrazadera Doble M6

Bricomatado / Bichomaté / Yellow Zinc Plated / Passivado Amarelo

PCL 106



CÓDIGO CODE / CODE / CÓDIGO	DIMENSÕES (mm) SIZE / DIMENSIONS / MEDIDA	DIMENSÕES" SIZE / DIMENSIONS / MEDIDA	EMBALAGEM QUANTITY / EMBALLAGE / EMBALAJE
010613014000	14 - 16	-	50
010613018000	18 - 20	3/8	50
010613022000	22 - 24	1/2	50
010613028000	26 - 28	-	50



**Tubos Metálicos**  
Light Metal Tubes  
Tubes Métalliques  
Tubos Metálicos





# ABRAÇADEIRAS METÁLICAS

Metallic Cable Ties / Colliers Métalliques / Abrazaderas Metálicas

## Abraçadeira Hércules

Robust clamp / Collier grande pression / Abrazadera de Gran Presión

Zincado / Zinc plated / Zingué / Zincado



CÓDIGO CODE / CODE / CÓDIGO	DIMENSÕES (mm) SIZE / DIMENSIONS / MEDIDA	DIMENSÕES" SIZE / DIMENSIONS / MEDIDA	EMBALAGEM QUANTITY / EMBALLAGE / EMBALAJE
000012604608	27-31	3/4	50
000012604601	33-37	1	50
000012604602	43-47	1 1/4	50
000012604609	49-54	1 1/2	50
000012604604	62-67	2	50
000012604603	77-83	2 1/2	50
000012604605	90-96	3	50
000012604611	98-105	3 1/2	50
000012604606	104-115	4	50
000012604607	137-145	5	50



### Aplicações industriais | Indústria automóvel | Agricultura

Industrial and agricultural applications | Automobile industry  
Applications industrielles | Industrie automobile | Agriculture  
Aplicaciones industriales | Industria automóvil | Agricultura



## Abraçadeira Escape e Gás

Auto exhaust and gas clamp / Collier pour échappement et gaz / Abrazadera Tubo de Escape e Gás

Escape

Zincado / Zinc plated / Zingué / Zincado



CÓDIGO CODE / CODE / CÓDIGO	DIMENSÕES SIZE / DIMENSIONS / MEDIDA	EMBALAGEM QUANTITY / EMBALLAGE / EMBALAJE
000012168801	M8 x 48	25



### Escapes automóveis e silenciadores | Tubos industriais

Automotive exhaust and mufflers | Industrial pipes  
Échappement automobiles et silencieux | Tubes industriels  
Escapes automóviles y silenciadores | Tubos industriales

Gás

Zincado / Zinc plated / Zingué / Zincado



CÓDIGO CODE / CODE / CÓDIGO	DIMENSÕES" SIZE / DIMENSIONS / MEDIDA	EMBALAGEM QUANTITY / EMBALLAGE / EMBALAJE
000013976501	3/8	100
000013976502	3/16	100



### Instalações de redes de gás domésticas e industriais

Domestic and industrial gas installations  
Installation de réseaux de gaz domestique et industriels  
Instalaciones de redes de gas domésticas y industriales

## Rolo de fita perfurada **PCL 3018**

Rouleau de Bande Perforée / Steel fixing band / Rollo Cinta Perforada

Galvanizado / Galvanisé / Galvanized / Galvanizado

PCL 151

**G**

CÓDIGO CODE / CODE / CÓDIGO	DIMENSÕES SIZE / DIMENSIONS / MEDIDA	COMPIMENTO LENGTH / LONGUEUR / LONGITUD	EMBALAGEM QUANTITY / EMBALLAGE / EMBALAJE
301812120080	12 x 0,8	10mt	10
301812170080	17 x 0,8	10mt	10

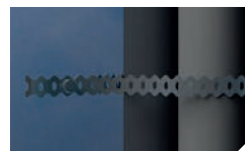
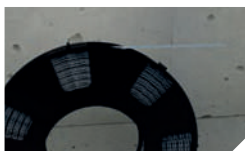

## Sistema Stripsteel **PCL 3017**

Stripsteel system / Système stripsteel / Sistema stripsteel

Inoxidable A2 / Inoxydable A2 / Stainless steel A2 / Aço inox A2

**A2**  
INOX

CÓDIGO CODE / CODE / CÓDIGO	DIMENSÕES SIZE / DIMENSIONS / MEDIDA	COMPIMENTO LENGTH / LONGUEUR / LONGITUD	EMBALAGEM QUANTITY / EMBALLAGE / EMBALAJE
301761100825	8	25mt	10
301781210900 (Uniblock)	-	-	50

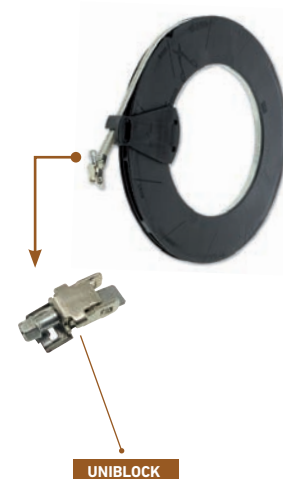



**O SEU FORNECEDOR DE SEMPRE,  
ONDE ESTIVER!**

*/ Your ever-ready supplier, wherever you are! / Votre fournisseur de toujours, où que vous soyez! / Su proveedor de siempre, donde esté!*

[HTTP://STORE.PECOL.PT/](http://store.pecol.pt/)

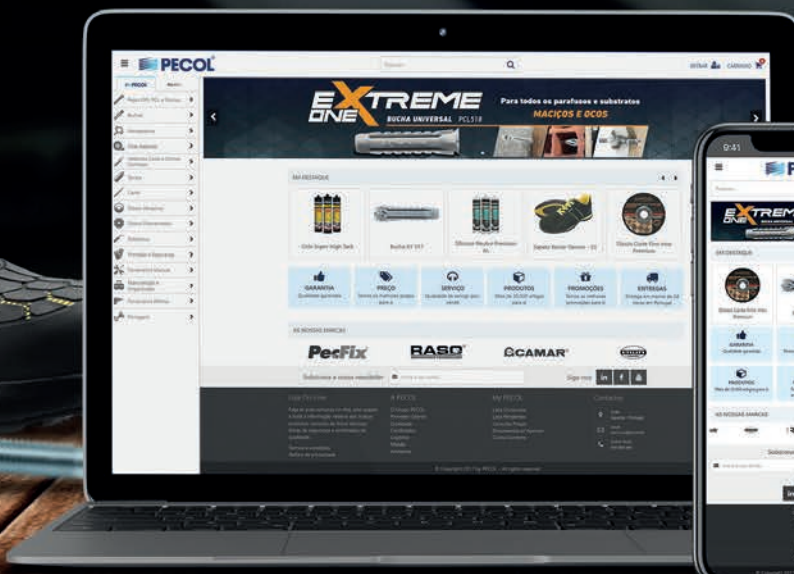





# INSTALADORES

*FRAMING SYSTEMS  
SUPPORTAGE  
SOPORTACION*



# INSTALADORES

Framing Systems / Supportage / Soportacion

## Suportes Perforados

Channel cantilever arms / Supports perforés / Soportes perforados

Zincado / Zinc Plated / Zingué / Zincado



CÓDIGO CODE / CODE / CÓDIGO	DIMENSÕES SIZE / DIMENSIONS / MEDIDA	COMPRIMENTO LENGTH / LONGUEUR / LONGITUD	EMBALAGEM QUANTITY / EMBALLAGE / EMBALAJE
000960000031	27 x 18 x 1,25	200	10
000960000032	27 x 18 x 1,25	300	10
000960000035	38 x 40 x 2	300	10
000960000037	38 x 40 x 2	400	10
000960000038	38 x 40 x 2	500	10
000960000039	38 x 40 x 2	600	10



CÓDIGO CODE / CODE / CÓDIGO	DIMENSÕES SIZE / DIMENSIONS / MEDIDA	COMPRIMENTO LENGTH / LONGUEUR / LONGITUD	EMBALAGEM QUANTITY / EMBALLAGE / EMBALAJE
000960000040	41 x 21 x 2,5	150	10
000960000041	41 x 21 x 2,5	300	10
000960000042	41 x 21 x 2,5	450	10
000960000043	41 x 41 x 2,5	150	10
000960000044	41 x 41 x 2,5	300	10
000960000045	41 x 41 x 2,5	450	10
000960000046	41 x 41 x 2,5	600	10
000960000047	41 x 41 x 2,5	750	10

## Esquadros

Channel bracket / Équerres / Escuadras

Zincado / Zinc Plated / Zingué / Zincado



CÓDIGO CODE / CODE / CÓDIGO	DIMENSÕES SIZE / DIMENSIONS / MEDIDA	EMBALAGEM QUANTITY / EMBALLAGE / EMBALAJE
000960000054	45°	100
000960000056	180°	100



## Calhas perforadas

Slotted strut channel / Rail perforé / Guia Perforada

Zincado / Zingú / Zinc Plated / **Zincado**

**Z**  
ZINC

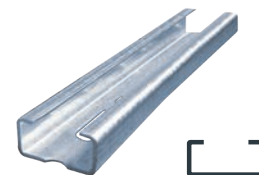

**CÓDIGO**  
CODE / CODE / CÓDIGO

**DIMENSÕES**  
SIZE / DIMENSIONS  
/ MEDIDA

**COMPRIMENTO**  
LENGTH / LONGUEUR / LONGITUD

**EMBALAGEM**  
QUANTITY / EMBALLAGE /  
EMBALAJE

00096000002

20x10x1,0

2000

1

Galvanizado / Galvanizé / Galvanized / **Galvanizado**

**G**

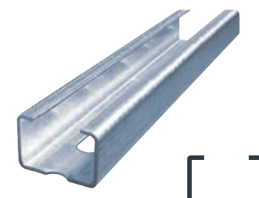

**CÓDIGO**  
CODE / CODE / CÓDIGO

**DIMENSÕES**  
SIZE / DIMENSIONS  
/ MEDIDA

**COMPRIMENTO**  
LENGTH / LONGUEUR / LONGITUD

**EMBALAGEM**  
QUANTITY / EMBALLAGE /  
EMBALAJE

000960000011

27x18x1,25

2000

1

000960000012

28x30x1,80

2000

1

000960000013

38x40x2,00

2000

1

000960000014

40x20x1,50

2000

1

Galvanizado / Galvanizé / Galvanized / **Galvanizado**

**G**

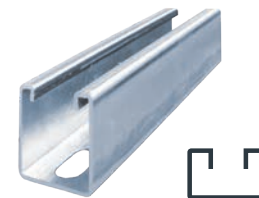

**CÓDIGO**  
CODE / CODE / CÓDIGO

**DIMENSÕES**  
SIZE / DIMENSIONS  
/ MEDIDA

**COMPRIMENTO**  
LENGTH / LONGUEUR / LONGITUD

**EMBALAGEM**  
QUANTITY / EMBALLAGE /  
EMBALAJE

000960000021

41x21x2,00

3000

1

000960000022

41x21x2,50

3000

1

000960000024

41x41x1,50

3000

1

000960000023

41x41x2,00

3000

1

000960000025

41x41x2,50

3000

1





# INSTALADORES

Framing Systems / Supportage / Soportacion

## Parafusos para calha

Channel stud nut / Arrêt-vis guide / Tope-tornillo de guía perforada

Zincado / Zingué / Zinc Plated / Zincado



CÓDIGO CODE / CODE / CÓDIGO	DIMENSÕES SIZE / DIMENSIONS / MEDIDA	VÁLIDO PARA SUITABLE FOR/ VALABLE POUR/ VÁLIDO PARA	EMBALAGEM QUANTITY / EMBALLAGE / EMBALAJE
000960000061	M6x20	27x18/ 28x30 - 25/08	100
000960000063	M8x30	27x18/ 28x30 - 25/10	100
000960000064	M8x30	38x40 - 40/20	100
000960000065	M10x30	38x40 - 40/21	100

## Porcas para calha perfurada

Channel nuts / Écrous guide / Tope-tornillo de guía perforada

Zincado / Zingué / Zinc Plated / Zincado



CÓDIGO CODE / CODE / CÓDIGO	DIMENSÕES SIZE / DIMENSIONS / MEDIDA	VÁLIDO PARA SUITABLE FOR/ VALABLE POUR/ VÁLIDO PARA	EMBALAGEM QUANTITY / EMBALLAGE / EMBALAJE
000960000066	M6	20/10 - 25/8	100
000960000069	M10	25/8 - 27/18 - 28/30 - 38/41	100
000960000070	M8	41/41 - 41/21	100
000960000071	M10	41/41 - 41/22	100

## Porca com mola para calhas

Tuerca guía con muelle / Channel spring nut / Écrou guide avec ressort

Zincado / Zingué / Zinc Plated / Zincado



CÓDIGO CODE / CODE / CÓDIGO	DIMENSÕES SIZE / DIMENSIONS / MEDIDA	VÁLIDO PARA SUITABLE FOR/ VALABLE POUR/ VÁLIDO PARA	EMBALAGEM QUANTITY / EMBALLAGE / EMBALAJE
000960000072	M8	41/41 - 41/23	100
000960000073	M10	41/41 - 41/24	100





# **FITAS ADESIVAS**

ADHESIVE TAPES  
RUBAN ADHÉSIF  
CINTAS ADHESIVAS



# FITAS ADESIVAS

Tapes / Ruban Adhésif / Cintas Adhesivas

## Fita Dupla Face

Double Sided Tapes / Rubans Double Face / Cintas Doble Cara

### Fita Dupla Face HD / Double Sided Foam Tape HD / Ruban Double Face HD / Cinta Doble Cara HD



#### Utilizações

- Indicada para fixar perfis, acessórios e em acabamentos na indústria automóvel;
- Ideal para fixar guarnições de móveis, placas de sinalização e outros objetos;
- Indicada para fixar acessórios em cozinhas e casas de banho.

Espessura sem película  
/ Thickness Without Liner  
/ Épaisseur sans pellicule  
/ Espesor sin película

1500 µ\* / 1,5 mm

\* µ: micron

Resistência à tração  
/ Tensile strength  
/ Résistance à la traction  
/ Resistencia a la tracción

25 N / cm

Resistência ao calor  
/ Heat Resistance  
/ Résistance à la chaleur  
/ Resistencia al calor

-10°C ~ +60°C



#### Applications

- Suitable to fix profiles, accessories, trims at automotive production;
- Ideal for fixing trim on furniture and sign boards;
- Suitable for fixing hanging kitchen and bathroom accessories.

#### Utilisations

- Indiqué pour fixation de profils, accessoires et finitions dans l'industrie automobile;
- Idéal pour fixation de garnison de meubles, plaques de signalisation et autres objets;
- Indiqué pour fixation d'accessoires en cuisines et salles de bain.

#### Utilización

- Indicada para fijar perfiles, accesorios y acabados en la industria automovil;
- Ideal para fijar accesorios de muebles y placas de señalización;
- Indicada para fijar accesorios en cocinas y cuartos de baño.

CÓDIGO CODE / CODE / CÓDIGO	COR COLOR / COULEUR / COLOR	DIMENSÕES DIMENSIONS / DIMENSIONS / DIMENSIONES	EMBALAGEM QUANTITY / EMBALLAGE / EMBALAJE
001905019000	Verde/Preta Green/Black   Vert/Noir   Verde/Negra	19 mm x 10 m	192 Uni.
001905025000	Verde/Preta Green/Black   Vert/Noir   Verde/Negra	25 mm x 10 m	144 Uni.

### Fita Dupla Face Light / Double Sided Eva Foam Tape Light / Ruban Double Face Light / Cinta Doble Cara Light



#### Utilizações

- Especialmente usada em madeira, vidro e superfícies metálicas.

Espessura sem película  
/ Thickness Without Liner  
/ Épaisseur sans pellicule  
/ Espesor sin película

1000 µ\* / 1,5 mm

\* µ: micron

Resistência à tração  
/ Tensile strength  
/ Résistance à la traction  
/ Resistencia a la tracción

15 N / cm

Resistência ao calor  
/ Heat Resistance  
/ Résistance à la chaleur  
/ Resistencia al calor

-10°C ~ +60°C

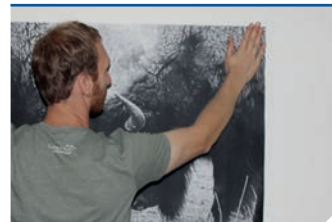

#### Applications

- Specially used on wood, glass and metal surfaces.

#### Utilisations

- Spécialement utilisé sur bois, verre et surfaces métalliques.

#### Utilización

- Especialmente usada en madera, vidrio y superficies metálicas.

CÓDIGO CODE / CODE / CÓDIGO	COR COLOR / COULEUR / COLOR	DIMENSÕES DIMENSIONS / DIMENSIONS / DIMENSIONES	EMBALAGEM QUANTITY / EMBALLAGE / EMBALAJE
001905019001	Amarela/Branca Yellow/White   Jaune/Blanc   Amarilla/Blanc	19 mm x 10 m	192 Uni.
001905025001	Amarela/Branca Yellow/White   Jaune/Blanc   Amarilla/Blanc	25 mm x 10 m	144 Uni.

## Fita Americana

Cloth Duct Tape / Ruban Américain / Cinta Americana



#### Utilizações

- Reparação de tubos ;
- Proteção de tubagens;
- Embalagens;
- Marcação e união de cabos;
- Proteção e reforço de arestas afiadas;
- Marcação de pisos;
- Selagem de condutas de ventilação;
- Reparações temporárias.

Espessura da Fita  
/ Thickness  
/ Épaisseur du ruban  
/ Espesor de la Cinta

200 µ\* / 0,2mm

\* µ: micron

Resistência à tração  
/ Tensile strength  
/ Résistance à la traction  
/ Resistencia a la tracción

49 N / cm

Resistência ao calor  
/ Heat Resistance  
/ Résistance à la chaleur  
/ Resistencia al calor

-10°C ~ +60°C

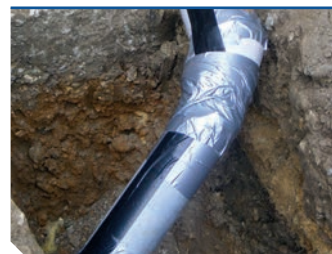

#### Applications

- Underground pipelines;
- Pipe wrapping and protection;
- Heavy duty packaging;
- Marking, bandaging and attaching cables;
- Padding of sharp edged items and reinforcing edges;
- Marking of floors;
- Sealing ventilation ducts;
- Temporary repairing.

#### Utilisations

- Réparation de tubes;
- Protection de tuyauteries;
- Emballages;
- Marquage et union de câbles;
- Protection et renfort d'arêtes affûtées;
- Marquage au sol;
- Scellement de conduits de ventilation;
- Réparations temporaires.

#### Utilización

- Reparación de tubos ;
- Protección de tuberías;
- Envasas;
- Marcadón y unión de cables;
- Protección y refuerzo de aristas afiladas;
- Marcadón de pisos;
- Sellado de conductos de ventilación;
- Reparaciones temporales.

CÓDIGO CODE / CODE / CÓDIGO	ESPESSURA THICKNESS / ÉPAISSEUR / ESPESOR	DIMENSÕES DIMENSIONS / DIMENSIONS / DIMENSIONES	EMBALAGEM QUANTITY / EMBALLAGE / EMBALAJE
001912048250	0,13 mm	48 mm x 25 m	72 Uni.
001912048251	0,13 mm	48 mm x 25 m	72 Uni.



## Fita de Alumínio

Aluminium Tapes / Ruban Aluminium / Cintas de Aluminio

Cinta de Alumínio / Ruban Aluminium / Aluminium Foil Tape / Fita de Alumínio



### Utilizações

- Vedação de condutas metálicas ou plásticas em ambientes industriais;
- Reflexão de calor na indústria eletrônica;
- União de rolos de lã de vidro;
- Vedação de condutas de ventilação.

Espessura da Fita  
/ Thickness  
/ Épaisseur du ruban  
/ Espesor de la Cinta

50 μ\* / 0,05 mm

\* μ: micron

Resistência à tração  
/ Tensile strength  
/ Résistance à la traction  
/ Resistencia a la tracción

>1,5 kn/m

Resistência ao calor  
/ Heat Resistance  
/ Résistance à la chaleur  
/ Resistencia al calor

-30°C ~ +120°C

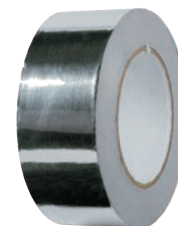

### Applications

- Sealing metal or plastic ducting in nuclear power stations;
- Heat reflexion and screening in electronic industry;
- Joining foil faced fibre on rockwool;
- Sealing cold ducts insulation.

### Utilisations

- Scellement de conduits métalliques ou plastiques en environnements industriels;
- Réflexion de chaleur dans l'industrie électronique;
- Union de rouleaux en laine de verre;
- Scellement de conduits de ventilation.

### Utilización

- Sellado de conductos metálicos o plásticos en ambientes industriales;
- Reflexión de calor en la industria electrónica;
- Unión de rollos de lana de vidrio;
- Sellado de conductos de ventilación.

### CÓDIGO

CODE / CODE / CÓDIGO

001901400000

### ESPESSURA

THICKNESS / ÉPAISSEUR / ESPESOR

50μ

### DIMENSÕES

DIMENSIONS / DIMENSIONS / DIMENSIONES

50 mm x 50 m

### EMBALAGEM

QUANTITY / EMBALLAGE / EMBALAJE

36 Uni.

## Fita Adesiva de Embalagem

BOPP Packaging Tape / Ruban Adhésif d'Emballage / Cinta Adhesiva de Embalaje



### Utilizações

- Indicada para proteger superfícies e embalagens em geral.

Espessura da Fita  
/ Thickness  
/ Épaisseur du ruban  
/ Espesor de la Cinta

40 μ\* / 0,04mm

\* μ: micron

Resistência à tração  
/ Tensile strength  
/ Résistance à la traction  
/ Resistencia a la tracción

80~160 N / cm

Resistência ao calor  
/ Heat Resistance  
/ Résistance à la chaleur  
/ Resistencia al calor

-10°C ~ +60°C



### Applications

- Suitable for filming surfaces, box sealing and general packaging.

### Utilisations

- Indiqué pour protéger les surfaces et emballages en générale.

### Utilización

- Indicada para proteger superficies y embalajes en general.

### CÓDIGO

CODE / CODE / CÓDIGO

001904050000

### DESCRIÇÃO

DESCRIPTION / DESCRIPTION / DESCRIPCIÓN

Fita Adesiva Transparente

### DIMENSÕES

DIMENSIONS / DIMENSIONS / DIMENSIONES

50 mm x 66 m

### EMBALAGEM

QUANTITY / EMBALLAGE / EMBALAJE

72 Uni.

001904150000

Fita Adesiva Castanha

50 mm x 66 m

72 Uni.

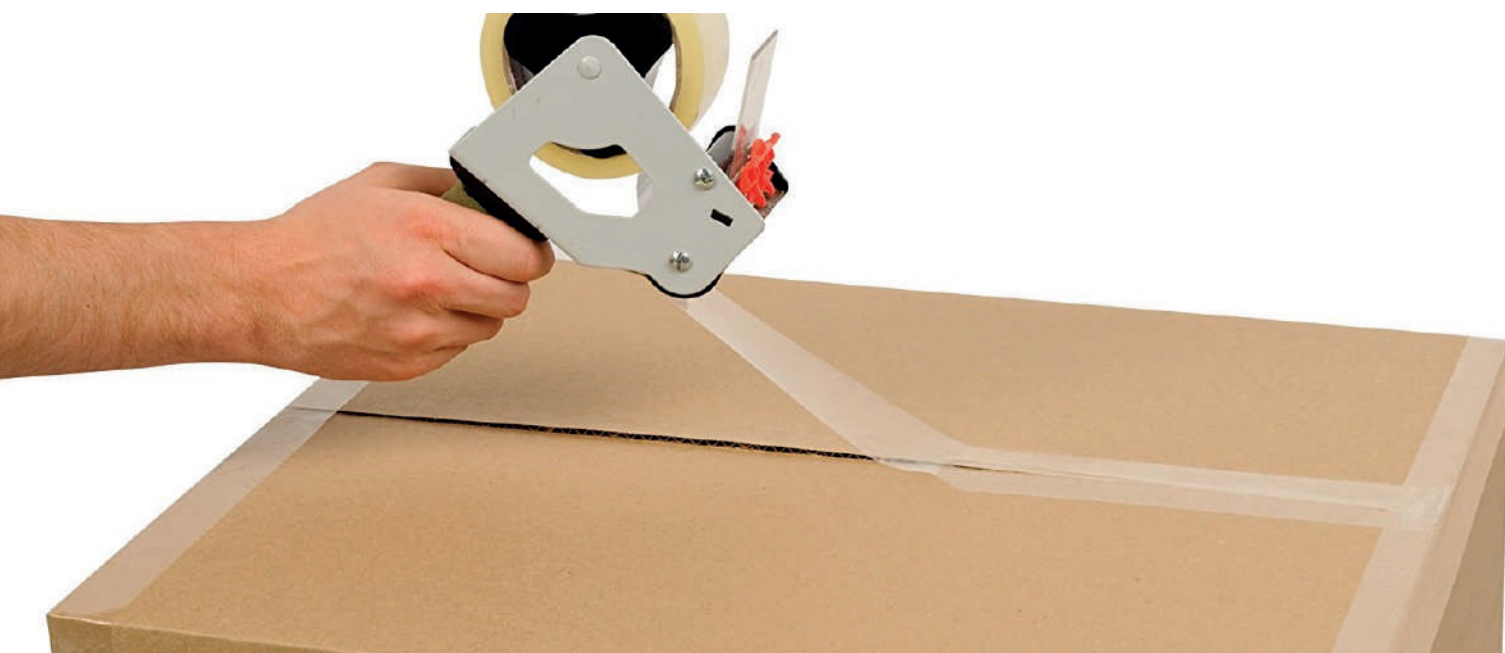



# FITAS ADESIVAS

Tapes / Ruban Adhésif / Cintas Adhesivas

## Fitas de Pintura

Masking Tapes / Rubans de Peinture / Cinta de Pintor

### Fita de Pintura / Masking Tape / Ruban de Peinture / Cinta de Pintor



#### Utilizações

• Ideal para marcação, isolamento e proteção de superfícies a serem pintadas ou envernizadas.

Espessura da Fita  
/ Thickness  
/ Épaisseur du ruban  
/ Espesor de la Cinta

140 µ\* / 0,14 mm

\* µ: micron

Resistência à tração  
/ Tensile strength  
/ Résistance à la traction  
/ Resistencia a la tracción

50 N/cm

Resistência ao calor  
/ Heat Resistance  
/ Résistance à la chaleur  
/ Resistencia al calor

0°C ~ +60°C



#### Applications

• Widely applied in fixing and covering surfaces during decoration, furniture painting, construction sealing on worksites, etc

#### Utilisations

• Idéal pour le marquage, isolation et protection de surfaces à peindre ou vernir.

#### Utilización

• Ideal para marcación, aislamiento y protección de superficies que van a ser pintadas o barnizadas.

#### CÓDIGO

CODE / CODE / CÓDIGO

001902025000

001902038000

001902050000

#### DIMENSÕES

DIMENSIONS / DIMENSIONS / DIMENSIONES

25 mm x 50 m

38 mm x 50 m

50 mm x 50 m

#### EMBALAGEM

QUANTITY / EMBALLAGE / EMBALAJE

144 Uni.

96 Uni.

72 Uni.

### Filme e Fita de Pintura / Film and Paper Masking Tape / Filme et Ruban de Peinture / Film y Cinta de Pintor



#### Utilizações

• Pintura de paredes e acabamentos

Espessura da Fita  
/ Thickness  
/ Épaisseur du ruban  
/ Espesor de la Cinta

160 µ\* / 0,16 mm

\* µ: micron

Resistência à tração  
/ Tensile strength  
/ Résistance à la traction  
/ Resistencia a la tracción

9,8 N/cm

Resistência ao calor  
/ Heat Resistance  
/ Résistance à la chaleur  
/ Resistencia al calor

-10°C ~ +80°C

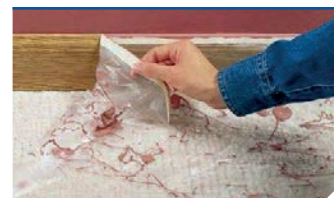

#### Applications

• Used in wall painting;  
• Refinishing painting jobs.

#### Utilisations

• Peinture de murs et finitions.

#### Utilización

• Pintura de paredes y acabados.

#### CÓDIGO

CODE / CODE / CÓDIGO

001908011000

#### DIMENSÕES

DIMENSIONS / DIMENSIONS / DIMENSIONES

1100mm x 30m

#### EMBALAGEM

QUANTITY / EMBALLAGE / EMBALAJE

30 Uni.

## Fitas Isoladoras

PVC Insulating Tape / Rubans d'Isolation / Cintas Aislantes



EN 60454-3-1



#### Utilizações

• Isolamento e proteção de cabos elétricos

Espessura  
/ Thickness  
/ Épaisseur  
/ Espesor

115 µ\* / 0,115mm

\* µ: micron

Resistência à tração  
/ Tensile strength  
/ Résistance à la traction  
/ Resistencia a la tracción

22 N / cm

Resistência ao calor  
/ Heat Resistance  
/ Résistance à la chaleur  
/ Resistencia al calor

-12°C ~ +80°C

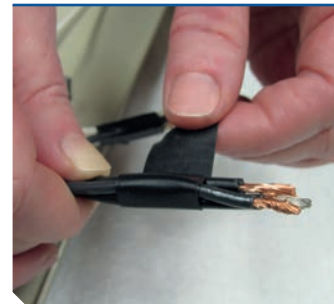

#### Applications

• For all normal insulation works, repair of damage insulation, wrapping cable ends and branches, stripping armatures and coils, labeling and marking.

#### Utilisations

• Aislamiento y protección de cables eléctricos.

#### Utilización

• Aislamiento y protección de cables eléctricos;  
• Utilizar con menos de 600V.

#### CÓDIGO

CODE / CODE / CÓDIGO

001910019201

001910019202

001910019203

001910019204

001910019205

001910019206

001910019207

#### COR

COLOR / COULEUR / COLOR

Vermelha /Red /Rouge /Roja

Azul /Blue /Bleu /Azul

Verde /Green /Vert /Verde

Amarela /Yellow /Jaune /Amarilla

Preta /Black /Noir /Negra

Branca /White /Blanc /Blanca

Amarela/Verde | Yellow/Green | Jaune/Vert | Amarilla/Verde

#### DIMENSÕES

DIMENSIONS / DIMENSIONS / DIMENSIONES

19 mm x 20 m

19 mm x 20 m

19 mm x 20 m

19 mm x 20 m

19 mm x 20 m

19 mm x 20 m

19 mm x 20 m

#### EMBALAGEM

QUANTITY / EMBALLAGE / EMBALAJE

10 Uni.

10 Uni.

10 Uni.

10 Uni.

10 Uni.

10 Uni.

10 Uni.







## Fitas PTFE (Teflon)

PTFE (Teflon) Tapes / Rubans PTFE (Téflon) / Cintas PTFE (Teflón)

Água / Eau / Water / **Água**



### Utilizações

- Encaixe de tubagens (industriais e sanitárias)

Espeçura  
/ Thickness  
/ Épaisseur  
/ Espesor  
-----  
75-100 µ\* / 0,075-0,1 mm

\* µ: micron

Densidade  
/ Density  
/ Densité  
/ Densidad  
-----  
0,25g/cm2

Resistência ao calor  
/ Heat Resistance  
/ Résistance à la chaleur  
/ Resistencia al calor  
-----  
+260°C



**Applications**  
• Pipe fitting (industrial and sanitary).

**Utilisations**  
• Raccords de tuyauteries (industriels et sanitaires).

**Utilización**  
• Encaje de tuberías (industriales y sanitarias).

CÓDIGO CODE / CODE / CÓDIGO	DENSIDADE DENSITY / DENSITÉ / DENSIDAD	DIMENSÕES DIMENSIONS / DIMENSIONS / DIMENSIONES	EMBALAGEM QUANTITY / EMBALLAGE / EMBALAJE
001906012075	0,25 g/cm3	12 mm x 0,75 mm x 10 m	10 Uni.
001906012000	0,25 g/cm3	12 mm x 0,1 mm x 10 m	10 Uni.

Gas / Gaz / Gas / **Gás**



### Utilizações

- Encaixe de tubagens (industriais e sanitárias)

Espeçura  
/ Thickness  
/ Épaisseur  
/ Espesor  
-----  
100 µ\* / 0,1 mm

\* µ: micron

Densidade  
/ Density  
/ Densité  
/ Densidad  
-----  
1g/cm2

Resistência ao calor  
/ Heat Resistance  
/ Résistance à la chaleur  
/ Resistencia al calor  
-----  
+260°C



**Applications**  
• Pipe fitting (industrial and sanitary).

**Utilisations**  
• Raccords de tuyauteries (industriels et sanitaires).

**Utilización**  
• Encaje de tuberías (industriales y sanitarias).

CÓDIGO CODE / CODE / CÓDIGO	DENSIDADE DENSITY / DENSITÉ / DENSIDAD	DIMENSÕES DIMENSIONS / DIMENSIONS / DIMENSIONES	EMBALAGEM QUANTITY / EMBALLAGE / EMBALAJE
001906012001	1 g/cm3	12 mm x 1 mm x 12 m	10 Uni.

## Fita de Marcação

PE Warning Tape / Ruban de Signalisation / Cinta de Balizamiento



### Utilizações

- Guias de trânsito;
- Proteção e aviso;
- Delimitação de áreas.

Espeçura da Fita  
/ Thickness  
/ Épaisseur du ruban  
/ Espesor de la Cinta  
-----  
30 µ\* / 0,03 mm

\* µ: micron

Resistência à tração  
/ Tensile strength  
/ Résistance à la traction  
/ Resistencia a la tracción  
-----  
15 N / cm

Alongamento à Ruptura  
/ Elongation at Break  
/ Allongement à la rupture  
/ Allongement à la rupture  
-----  
200 %



**Applications**  
• Protection and delimitation of:  
• Dander areas;  
• Pedestrian pathways;  
• Industrial areas;  
• Parking areas.

**Utilisations**  
• Guides de transit;  
• Protection et avertissement;  
• Délimitation de zones.

**Utilización**  
• Guías de tráfico;  
• Protección y aviso;  
• Delimitación de áreas.

CÓDIGO CODE / CODE / CÓDIGO	COR COLOR / COULEUR / COLOR	DIMENSÕES DIMENSIONS / DIMENSIONS / DIMENSIONES	EMBALAGEM QUANTITY / EMBALLAGE / EMBALAJE
001913482002	Vermelha/Branca   Red/White   Rouge/Blanc   Roja/Blanca	48 mm x 200 m	36 Uni.



# FITAS ADESIVAS

Tapes / Ruban Adhésif / Cintas Adhesivas

## Fitas Auto-Soldantes

Self Fusing Tape / Adhésif Autosoudant / Cintas Auto Soldantes

### UltraFix Tape / UltraFix Tape / UltraFix Tape / UltraFix Tape



#### Utilizações

- Pode ser utilizada em reparações de mangueiras, equipamento desportivo ou ferramentas (criando aderência), em isolamentos de cabos elétricos, tubos de ar comprimido, entre outros.

Espessura da Fita  
/ Thickness  
/ Épaisseur du ruban  
/ Espesor de la Cinta

570 µ / 0,57 mm

\* µ: micron

Resistência à tração  
/ Tensile strength  
/ Résistance à la traction  
/ Resistencia a la tracción

1508psi (10.4Mpa)

Densidade  
/ Density  
/ Densité  
/ Densidad

1.16 g/m<sup>3</sup>

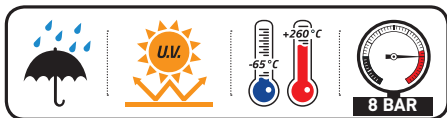
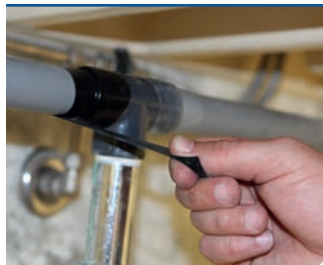

#### Applications

- It can be used in hoses repairs, sports equipment or tools (by creating tack) for insulating electrical cables, compressed air tubes, among others.

#### Utilisations

- Peut être utilisé dans la réparation de tuyaux, équipement sportif, outils (création d'adhérence) pour l'isolation des câbles électriques, tubes à air comprimé, entre autres.

#### Utilización

- Se puede utilizar en reparaciones de mangueras, equipamiento deportivo o herramientas (creando adherencia), para el aislamiento de cables eléctricos, tubos de aire comprimido, entre otros.

#### CÓDIGO

CODE / CODE / CÓDIGO

#### COR

COLOR / COULEUR / COLOR

#### DIMENSÕES

DIMENSIONS / DIMENSIONS / DIMENSIONES

#### EMBALAGEM

QUANTITY / EMBALLAGE / EMBALAJE

007000025503

Transparente / Transparent / Transparent / Transparente

25 mm x 3 m

8 Uni.

007000025504

Preta /Black /Noir /Negra

25 mm x 3 m

8 Uni.



**FITA SILICONE AUTO SOLDANTE**  
 SELF FUSING SILICONE RUBBER TAPE / ADHÉSIF SILICONE AUTOSOUĐANT  
 / CINTA DE SILICONA AUTO SOLDANTE



**A NOVA GERAÇÃO DE FITAS JÁ CHEGOU PERTO DE SI!!!**

NEW GENERATION TAPES ALREADY AVAILABLE NEAR YOU !!! / LA NOUVELLE GENERATION DE BANDES ADHÉSIVES EST ARRIVÉ CHEZ VOUS / LA NUEVA GENERACIÓN DE CINTAS YA LLEGÓ A USTED !!!

# ULTRAFIX TAPE



✓ **Excelente resistência à humidade e aos raios U.V.**  
 Excellent resistance to humidity and U.V. / Excellente résistance à l'humidité et aux rayons U.V.  
 / Excelente resistencia a la humedad y los rayos U.V.

✓ **Elevada resistência dielétrica**  
 High dielectric resistance / Haute résistance diélectrique / Elevada resistencia dieléctrica

✓ **Grande resistência à corrosão**  
 High resistance to corrosion / Bonne résistance à la corrosion / Gran resistencia a la corrosión

✓ **Resiste até 8 bar de pressão**  
 Resists up to 8 bar pressure / Résiste jusqu'à 8 bars de pression / Resiste hasta 8 bar de presión

✓ **Resistência a temperaturas extremas (-65°C a +260°C)**  
 Resistance to extreme temperatures (-65 °C to + 260 °C) / Résiste aux températures extrêmes (-65 °C à + 260 °C) / Resistente a temperaturas extremas (-65 °C a + 260 °C)

✓ **Excelente agarre inicial**  
 / Excellent initial grab / Excellente prise initiale / Excelente agarre inicial

✓ **Isola completamente o ar e a água**  
 / Completely seals the air and water / Parfaitement étanchéité de l'air et l'eau / Aísla por completo del aire y del agua

Disponível em / Available in / Disponible en / Disponible en



**Transparente**  
 / Transparent  
 / Transparent  
 / Transparente



**Preta**  
 / Black  
 / Noir  
 / Negra

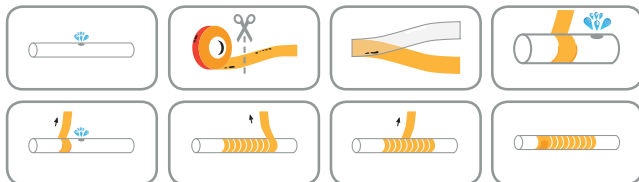

**Resiste a raios U.V., temperaturas (-65°C e +260°C), pressão, ácidos, solventes**  
Resists UV rays, temperature (-65°C and + 260°C), pressure, acids, solvents / Résiste aux rayons UV, températures (-65°C et + 260°C), à la pression, aux acides et aux solvants / Resistente los rayos UV, temperatura (-65°C y + 260°C), presión, ácidos, disolventes

**-65°C a +260°C**

**8 BAR**



# FITAS ADESIVAS

Tapes / Ruban Adhésif / Cintas Adhesivas

## Fitas para Gesso Cartonado

Drywall Tapes / Bandes pour Plâtre Cartonné / Cinta para Yeso Acartonado

### Fita de Papel para Gesso Cartonado / Drywall Joint Paper Tape / Ruban de Papier pour Plâtre Cartonné / Cinta de Papel para Yeso Acartonado

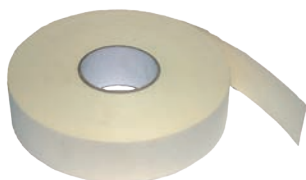

#### Utilizações

- Utilizada para reforço de juntas e cantos em paredes e tetos antes de pintar

**Espessura da Fita**  
/ Thickness  
/ Épaisseur du ruban  
/ Espesor de la Cinta  
.....  
**220 µ\* / 0,22 mm**

\* µ: micron

**Resistência à tração**  
/ Tensile strength  
/ Résistance à la traction  
/ Resistencia a la tracción  
.....  
**98 N / cm (seco)**

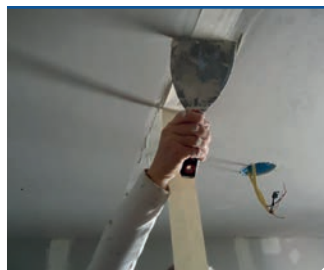

#### Applications

- Used to reinforce the gypsum board joints and corners before painting, texturing and wall papering.

#### Utilisations

- Utiliser pour renfort de joints et coins sur murs et plafonds avant de peindre.

#### Utilización

- Utilizada para refuerzo de juntas, esquinas y rincones en paredes y techos antes de pintar.

#### CÓDIGO

CODE / CODE / CÓDIGO

001903050150

#### COR

COLOR / COULEUR / COLOR

Creme /Cream /Crème /Crema

#### DIMENSÕES

DIMENSIONS / DIMENSIONS / DIMENSIONES

50 mm x 150 m

#### EMBALAGEM

QUANTITY / EMBALLAGE / EMBALAJE

16 Uni.

### Fita de Cantos para Gesso Cartonado / Metal Corner Drywall Tape / Bandes de Coins pour Plâtre Cartonné / Cinta de Esquinas y Rincones para Yeso Acartonado

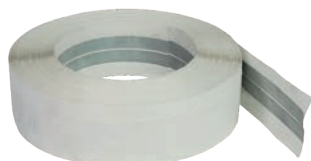

#### Utilizações

- Ideal para utilização nas mais variadas aplicações em gesso cartonado: cantos com ângulos interiores ou exteriores (Arcadas, tetos em abóbada, tetos com sancas e janelas de sacada, etc.)

**Espessura da Fita**  
/ Thickness  
/ Épaisseur du ruban  
/ Espesor de la Cinta  
.....  
**230 µ\* / 0,23 mm**

\* µ: micron

**Espessura da Fita de Metal**  
/ Metal thickness  
/ Épaisseur bande Métal  
/ Espesor do reforço em metal  
.....  
**0.21 - 0,25 mm**

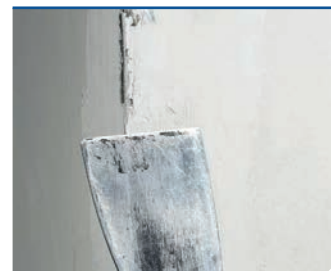
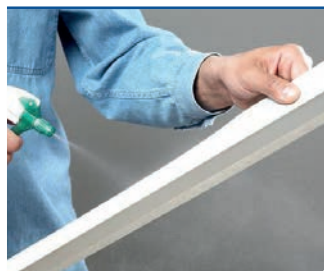

#### Applications

- Ideal for use in a variety of drywall applications: internal or external corners with different angles (Archways, curvey, vaulted ceiling, coffered ceiling, bay windows, etc.).

#### Utilisations

- Idéale pour utilisation dans les applications de plâtre cartonné les plus variées: Coins avec angles intérieurs ou extérieurs (arcades, plafonds en voûte, plafonds avec corniche et fenêtres à croisillons, etc.)

#### Utilización

- Ideal para utilización en las más variadas aplicaciones en yeso acartonado: esquinas y rincones (Arcadas, techos en bóvedas, techos con cornisas y ventanas de balcón, etc.)

#### CÓDIGO

CODE / CODE / CÓDIGO

001907050000

#### COR

COLOR / COULEUR / COLOR

Creme /Cream /Crème /Crema

#### DIMENSÕES

DIMENSIONS / DIMENSIONS / DIMENSIONES

50 mm x 30 m

#### EMBALAGEM

QUANTITY / EMBALLAGE / EMBALAJE

10 Uni.

## Fita para Fissuras

Fibre Glass Mesh / Bande à Fissures / Cinta para Fisuras



#### Utilizações

- Ideal para reparação de fissuras, juntas ou buracos em gesso cartonado.

**Malha**  
/ Mesh  
/ Maille  
/ Malla  
.....  
**3,1 x 3,1 mm**

**Densidade**  
/ Density  
/ Densité  
/ Densidad  
.....  
**65 g/m<sup>2</sup>**

**Resistência à tração**  
/ Tensile strength  
/ Résistance à la traction  
/ Resistencia a la tracción  
.....  
**200 N/25mm**



#### Applications

- Ideal to repair cracks, joints or holes of drywall and plasterboard.

#### Utilisations

- Idéale pour réparation de fissures, joints et trous sur plâtre para cartonné.

#### Utilización

- Ideal para reparación de fisuras, juntas o agujeros en yeso acartonado.

#### CÓDIGO

CODE / CODE / CÓDIGO

001909489065

#### DIMENSÕES

DIMENSIONS / DIMENSIONS / DIMENSIONES

48 mm x 90 m

#### DIMENSÕES DA MALHA

MESH DIMENSIONS / DIMENSIONS DE LA MAILLE / DIMENSIONES DE LA MALLA

3,1 x 3,1 mm

#### DENSIDADE

DENSITY / DENSITÉ / DENSIDAD

65 g/m<sup>2</sup>

#### EMBALAGEM

QUANTITY / EMBALLAGE / EMBALAJE

72 Uni.

# VEDAÇÃO E COLAGEM



SEALING AND BONDING  
ÉTANCHE ET COLLAGE  
SELLADO Y PEGADO

Excepcional aderência  
Adherencia Excepcional



# VEDAÇÃO E COLAGEM

Sealing and Bonding / Étanche et Collage / Sellado y Pegado

Silicone Neutro AL



Silicone Neutro



Silicone Neutro Sanitários



Silicone Neutro Construção



Silicone Neutro Altas Temperaturas



Silicone Altas Temperaturas Aerosol



Silicone Acetato



Silicone Acetato Sanitários



Cola e Veda PU



Cola e Veda Neutro Premium



Power Tack



Power Coat



MSP 70 Premium



MSP 50 Premium



MSP 30 Premium



MSP Cristal Premium



Cola de Montagem Premium



Prego Líquido Special



Cola para Sancas e Molduras



Selante Acrílico



Selante Madeira



Cola PU Express Multifibras Premium



Cola PU Express



Selante Refratário



Consulte a restante gama no nosso

## CATÁLOGO

/Check the entire catalogue  
/ Vérifiez toute le catalogue  
/ Compruebe todo ele catálogo

# PECOL<sup>®</sup> ECO SYSTEM

## Cartucho Reutilizável

/ Reusable Cartridge / Cartouche Réutilisable / Cartucho Reutilizable



### ✓ MAIS ECONÓMICO

/ ECONOMICAL / PLUS ÉCONOMIQUE / MÁS ECONÓMICO

- Reduz os custos com o tratamento de resíduos.  
/ Reduce the cost treatment of the waste packages / Réduit les coûts avec le traitement des résidus / Reduce the costs with the treatment of residues
- Custo do produto mais barato que em cartucho convencional.  
/ Lower product cost / Le coût du produit moins cher que la cartouche traditionnelle / Coste del producto más barato que en cartucho convencional
- Utilização total, sem desperdício de produto.  
/ No product waste. Aluminium foils provides full consumption / Utilisation totale, sans gaspillage du produit / Utilización total, sin desperdicio de producto

### ✓ MAIS ECOLÓGICO

/ ECOLOGICAL / PLUS ÉCOLOGIQUE / MÁS ECOLÓGICO

- Evita o desperdício do cartucho (convencional) de polipropileno.  
/ Avoids disposable PP cartridges / Évite le gaspillage de la cartouche (ordinaire) de polypropylène / Evita el desperdicio del cartucho (convencional) de polipropileno.
- Foil em alumínio reciclável.  
/ Recyclable aluminium foil / Sachet en aluminium recyclable / Foil en aluminio reciclable

### ✓ MAIS VERSÁTIL

/ VERSATILITY / PLUS VERSATILITÉ / MÁS VERSÁTIL

- Vários produtos disponíveis: Silicone, Cola e Veda, MSP.  
/ The system is suitable for different types of sealants: Silicone, PUR, MSP, Acrylic... / Plusieurs produits à disposition: Silicone, Mastic de PU, MSP / Varios productos disponibles: Silicona, Pega y Sella (PU), MSP
- Funciona com uma pistola de aplicação convencional.  
/ Do not need special caulking guns / Fonctionne avec un pistolet d'application conventionnel / Funciona con una pistola de aplicación convencional



300ml

-85%

DE RESÍDUO  
/ OF RESIDUE / DE RESIDUE / DE RESIDUOS

### ✓ CARTUCHO REUTILIZÁVEL

/ REUSABLE CARTRIDGE / CARTOUCHE RÉUTILISABLE / CARTUCHO REUTILIZABLE

- Com o mesmo cartucho pode utilizar vários produtos em Foil.  
/ With same reusable PP cartridge can use different sealants in foil / Avec la même cartouche on peut utiliser plusieurs produits en sachets / Con el mismo cartucho puede utilizar varios productos en Foil.

## CONHEÇA MELHOR O NOSSO ECO SYSTEM

KNOW MORE ABOUT OUR INNOVATIVE ECO SYSTEM / CONNAISSEZ MIEUX NOTRE ECO SYSTEM / CONOZCA MEJOR NUESTRO ECO SYSTEM



125 CARTUCHOS

Cartridge / Cartouche / Cartucho

75L

125 FOILS

Foil / Sachet / Foil

9L

ÊMBOLO

/ Plunger / Piston / Êmbolo

ADAPTADOR

/ Cartridge cover / Adaptateur / Adaptador

CARTUCHO

/ Cartridge / Cartouche / Cartucho

FOIL  
300ml

/ Foil / Sachet / Foil

CÂNULA

/ Nozzle / Canule / Cànula



# VEDAÇÃO E COLAGEM

Sealing and Bonding / Étanche et Collage / Sellado y Pegado

## Silicone Neutro Premium AL

Neutral Silicone Premium AL / Silicone Neutre Premium AL / Silicona Neutra Premium AL



**ALCOXY TECHNOLOGY**

**CE**

14  
PECOL

EN 15651-1: F-EXT-INT-CC

EN 15651-2: G-CC

EN 15651-3: S

DoP: 31-31-14-1

www.pecol.pt

EMISSIONS DANS L'AIR INTERIEUR



O Silicone Neutro AL é um produto mono componente, sem solventes voláteis, de cura neutra alcoxy, alta elasticidade e baixo módulo, com excelente capacidade de adesão em quase todos os substratos usados na indústria e construção.

O produto vulcaniza em contacto com o ar e a humidade, criando um isolamento perfeito contra a chuva, neve, raios U.V., temperaturas, conservando-se permanentemente elástico.

### Características

- Excelente aderência sem primário em vidro, tijolo, cerâmica, anodizados, lacados, metais (alumínio, zinco, aço, cobre), madeira, PVC e vários plásticos;
- Para substratos porosos fazer testes previamente ou utilizar primário;
- Rápida formação de película;
- Fácil de aplicar e alisar;
- Validade: 18 meses.



Dados técnicos e ficha de segurança disponível sob pedido.

/ Technical information and safety data sheet available under request / Données techniques et fiche de sécurité disponible sur demande / Datos técnicos y ficha de seguridad disponible bajo pedido

dep.technico@pecol.pt

Neutral Silicone AL is a one part, alcoxy neutral curing, low modulus silicone sealant, with excellent adhesion and long shelf life for perimeter sealing and glazing applications. It cures at room temperature, under the action of atmospheric moisture to give a permanent flexible silicone rubber.

### Characteristics

- The Neutral Silicone AL Premium exhibits excellent primerless adhesion to most substrates used in sanitary areas, e.g., glass, tiles, ceramics, enamel, glazed tiles and clinker; metals e.g., aluminum, steel, zinc or copper; impregnable, varnished or painted wood; PVC and many plastics.
- The adhesion can be improved in many cases by pretreatment of the substrates with a primer;
- Quickly becomes tack free;
- easy application and finishing;
- Shelf life: 18 months.

Le Silicone Neutre AL est un produit mono-composant, neutre, base alcoxy, sans solvants volatils, de grande élasticité et bas module, avec une excellente capacité d'adhésion sur presque tous les supports utilisés dans l'industrie et la construction.

Le produit vulcanise en contact avec l'air et l'humidité, créant une isolation parfaite contre la pluie, neige, rayons UV, températures et se conservant complètement élastique.

### Caractéristiques

- Excellente adhésion sans primaire sur le verre, la brique, la céramique, les anodisés, les laqués, les métaux (aluminium, zinc, acier, cuivre), le bois, le PVC et divers plastiques;
- Pour les supports poreux faire des tests préalables ou utiliser un primaire;
- Formation rapide de pellicule;
- Application et lissage facile;
- Validité: 18 mois.

La Silicona Neutra AL es un producto monocomponente, sin solventes volátiles, de cura neutra alcoxy, alta elasticidad y bajo módulo, con excelente capacidad de adhesión en casi todos los materiales usados en la industria y construcción.

El producto vulcaniza en contacto con el aire y la humedad, creando un aislamiento perfecto contra la lluvia, nieve, rayos U.V., temperaturas, conservándose permanentemente elástica.

### Características

- Excelente adherencia sin imprimación en vidrio, ladrillo, cerámica, anodizados, lacados, metales (aluminio, zinc, acero, cobre), madera, PVC y varios plásticos;
- Para sustratos porosos hacer previamente pruebas o utilizar imprimación;
- Rápida formación de película;
- Fácil de aplicar y alisar;
- Caducidad: 18 meses.



CÓDIGO CODE / CODE / CÓDIGO	COR** COLOR / COULEUR / COLOR	CAPACIDADE CAPACITY / CAPACITÉ / CAPACIDAD	EMBALAGEM QUANTITY / EMBALLAGE / EMBALAJE	QTD. Paleta PALET / QT. PALETTE / CANT. PALÉ		
00200000001	Branco / White / Blanc / Blanco	9003	310 ml	25	1200	
00200000002	Transparente / Transparent / Transparent / Transparente		310 ml	25	1200	
00200000005	Preto / Black / Noir / Negro	9011	310 ml	12	1200	
00200000008	Cinza / Grey / Gris / Gris	7011	310 ml	12	1200	
00200000018	Cinza / Grey / Gris / Gris	7016	310 ml	12	1200	
00200000006	Cinza / Grey / Gris / Gris	7037	310 ml	12	1200	
00200000007	Alumínio / Aluminium / Aluminium / Aluminium	9007	310 ml	12	1200	
00200000014	Creme / Light ivory / Ivoire clair / Marfil claro	1015	310 ml	12	1200	
00200000009	Champanhe / Champagne / Champagne / Champán	7048	310 ml	12	1200	
00200000011	Carvalho / Oak / Chêne / Roble	1011	310 ml	12	1200	
00200000019	Nogueira / Fawn brown / Brun fauve / Pardo corzo	8007	310 ml	12	1200	
00200000015	Castanho / Sepia brown / Brun sépia / Sepia	8014	310 ml	12	1200	
00200000013	Bordeaux / Wine red / Rouge vin / Rojo vino	3005	310 ml	12	1200	
00200000017	Vermelho / Red / Rouge / Rojo	3003	310 ml	12	1200	
00200000003	Verde / Green / Vert / Verde	6005	310 ml	12	1200	
00200000016	Verde / Green / Vert / Verde	6200	310 ml	12	1200	
FOIL	00200000022	Branco / White / Blanc / Blanco	9003	300 ml	30	1440
FOIL	00200000024	Transparente / Transparent / Transparent / Transparente		300 ml	30	1440
FOIL	000000726203	Branco / White / Blanc / Blanco	9003	600 ml	18	720
FOIL	00200000025	Transparente / Transparent / Transparent / Transparente		600 ml	18	720



Disponível em  
/ Available in / disponible en  
/ Disponible

**PECOL**  
ECO SYSTEM





# Silicone Neutro Special AL

Neutral Silicone Special AL / Silicone Neutre Special AL / Silicona Neutra Special AL

O Silicone Neutro AL Special é um produto mono componente de cura alcoxy, de baixo módulo e com excelentes propriedades de adesão e durabilidade em diversas aplicações (construção, selagens e vidros).

O produto cura à temperatura ambiente, e em contacto com a humidade do ar, ficando com aspeto de borracha, flexível. O Silicone Neutro AL Special não é afetado por baixas ou altas temperaturas e é resistente à intempérie e aos raios U.V.

### Características

- O Silicone Neutro AL Special tem um excelente poder de agarre inicial na maioria dos materiais utilizados em aplicações sanitárias, nomeadamente vidro, azulejos, cerâmicas, lacados e tijolos envidraçados; em metais, tais como alumínio, aço, zinco, cobre, em madeira envernizada ou pintada; variados plásticos. O utilizador deve ter o cuidado de fazer um teste prévio, de forma a comprovar as propriedades do silicone no substrato a aplicar. A adesão pode melhorar, quando aplicado um primário;
- Odor agradável;
- Rápida formação de película;
- Fléxivel a baixas (-50°C) e a altas (+150°C) temperaturas;
- Não corrosivo em metais;
- Validade: 12 meses.



Dados técnicos e ficha de segurança disponível sob pedido.

/ Technical information and safety data sheet available under request / Données techniques et fiche de sécurité disponible sur demande / Datos técnicos y ficha de seguridad disponible bajo pedido  
dep.technico@pecol.pt



**ALCOXY**  
TECHNOLOGY

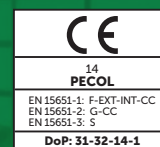

Neutral Silicone AL Special is a one component alcoxy neutral curing, low modulus silicone sealant, with excellent adhesion and long shelf life for construction, perimeter sealing and glazing applications. It cures at room temperature under the action of atmospheric moisture, to give a permanent flexible silicone rubber. The product is unaffected by high or low temperatures and has outstanding weathering and U.V. resistance.

### Characteristics

- The Neutral Silicone AL Special exhibits excellent primerless adhesion to most material used for sanitary application, e.g. glass, tiles, ceramics, enamel, glazed tiles and clinker; on metals, e.g. Aluminium, steel, zinc, copper, on varnished or painted wood; and some plastics. Users must carry out their own tests due to the great variety of substrates. The adhesion can be improved in many cases by pretreatment of the substrates with a primer;
- Almost odourless;
- Rapid crosslinking. Quickly becomes tack free;
- Flexible at low (-50°C) and high (+150°C) temperatures;
- Does not corrode metals;
- Shelf life: 12 months.

Le Silicone Neutre AL Special est un produit mono-composant, neutre, base alcoxy, sans solvants volatils, de grande élasticité et bas module, avec d'excellentes propriétés d'adhésion et de durabilité dans diverses applications (construction, scellement et verres). Le produit durci à température ambiante, en contact avec l'humidité de l'air, ayant l'aspect de caoutchouc flexible. Le Silicone Neutre AL Special n'est pas affecté par les basses ou hautes températures et est résistant aux intempéries et aux rayons U.V.

### Caractéristiques

- Le Silicone Neutre AL Special a une excellente adhésion sur la plupart des applications sanitaires telles que le verre, le carrelage, la céramique, les laqués et briques en verre ; les métaux, tels que l'aluminium, acier, zinc, cuivre, sur le bois peint ou vernis et des plastiques divers. L'utilisateur doit faire un test préalable, pour attester les propriétés du silicone sur le support. L'adhésion peut être améliorée en utilisant un primaire.
- Odeur agréable;
- Rapide formation de pellicule;
- Flexible à basse (-50°C) et haute (+150°C) températures;
- Non corrosif sur métaux;
- Validité: 12 mois.

La Silicona Neutra AL Special es un producto monocomponente de cura alcoxy, de bajo módulo y con excelentes propiedades de adhesión y durabilidad en diversas aplicaciones (construcción, sellados y vidrios). El producto cura a temperatura ambiente, y en contacto con la humedad del aire, quedando con aspecto de goma, flexible. La Silicona Neutra AL Special no se altera por bajas o altas temperaturas y es resistente a la intemperie y a los rayos U.V.

### Características

- La Silicona Neutra AL Special tiene un excelente poder de agarre inicial en la mayoría de los materiales utilizados en aplicaciones sanitarias, tales como vidrio, azulejos, cerámicas, lacados y ladrillos de vidrio; en metales, tales como aluminio, acero, zinc, cobre, en madera embarnizada o pintada; plásticos varios. El usuario debe tener cuidado de hacer una prueba previa, para comprobar las propiedades de la silicona en el sustrato a aplicar. La adhesión puede mejorar, cuando es aplicado en un primario;
- Olor agradable;
- Rápida formación de película;
- Flexible a bajas (-50°C) y altas (+150°C) temperaturas;
- No corrosivo en metales;
- Validez: 12 meses.



CÓDIGO CODE / CODE / CÓDIGO	COR** COLOR / COULEUR / COLOR		CAPACIDADE CAPACITY / CAPACITÉ / CAPACIDAD	EMBALAGEM QUANTITY / EMBALLAGE / EMBALAJE	QTD. Palete PALET / QT. PALETTE / CANT. PALÉ	
002006000000	Branco / White / Blanc / Blanco	9003	310 ml	25	1200	
002010000000	Transparente / Transparent / Transparent / Transparente		310 ml	25	1200	
002020000000	Preto / Black / Noir / Negro	9011	310 ml	12	1200	
002000000008	Cinza / Grey / Gris / Gris	7011	310 ml	12	1200	
002020000020	Cinza / Grey / Gris / Gris	7016	310 ml	12	1200	
002020000003	Cinza / Grey / Gris / Gris	7037	310 ml	12	1200	
002020000001	Alumínio / Aluminium / Aluminium / Aluminium	9007	310 ml	12	1200	
002020000010	Crema / Light ivory / Ivoire clair / Marfil claro	1015	310 ml	12	1200	
002020000011	Champanhe / Champagne / Champanhe / Champán	7048	310 ml	12	1200	
002020000005	Castanho / Sepia brown / Brun sépia / Sepia	8014	310 ml	12	1200	
002016000000	Verde / Green / Vert / Verde	6005	310 ml	12	1200	
000000726102	Branco / White / Blanc / Blanco	9003	300 ml	30	1440	FOIL
000000726101	Transparente / Transparent / Transparent / Transparente		300 ml	30	1440	FOIL
000000726202	Branco / White / Blanc / Blanco	9003	600 ml	18	720	FOIL
000000726201	Transparente / Transparent / Transparent / Transparente		600 ml	18	720	FOIL

\*\* Cor do produto aproximada à cor RAL / The color of the product is close to color RAL / Couleur du produit similaire a couleur RAL / Color del producto aproximada al color RAL



Disponível em  
/ Available in / disponible en  
/ Disponible

**PECOL**  
ECO SYSTEM





# VEDAÇÃO E COLAGEM

Sealing and Bonding / Étanche et Collage / Sellado y Pegado

## Silicone Neutro Premium

Neutral Silicone Premium / Silicóne Neutre Premium / Silicona Neutra Premium



O Silicone Neutro é um produto mono componente de cura neutra, pronto a aplicar, de baixo módulo e base oxime. Este Silicone foi concebido para a selagem e vedação de todos os tipos de caixilharias (PVC, alumínio, alumínio lacado, madeira). O produto garante uma adesão duradoura na maioria dos substratos porosos e não porosos, incluindo alvenaria, tijolos cerâmicos, alumínio, metais, PVC, poliacrilato, policarbonato, madeira envernizada ou pintada, vidro e superfícies vitrificadas.

O Silicone Neutro Premium cura à temperatura ambiente, em contacto com a humidade do ar, garantindo uma selagem forte e flexível com baixo módulo de elasticidade.

### Características

- O Silicone Neutro Premium tem uma excelente aderência sem primário na maioria dos substratos utilizados em áreas sanitárias, assim como vidro, tijolo, cerâmica, anodizados, lacados, metais (alumínio, zinco, aço e cobre), betão, madeira pintada ou envernizada, PVC e vários plásticos;
- Não tem contração de volume após a cura;
- Fortes propriedades anti fungos;
- Quase inodoro;
- Não corrosivo para metais;
- Flexível a baixas (-40°C) e altas temperaturas (+150°C);
- Validade: 12 meses.

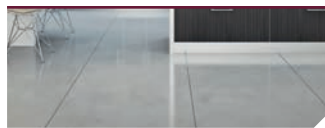

Dados técnicos e ficha de segurança disponível sob pedido.

Technical information and safety data sheet available under request / Données techniques et fiche de sécurité disponible sur demande / Datos técnicos y ficha de seguridad disponible bajo pedido dep. tecnico@pecol.pt

Neutral Silicone is a one part, neutral curing, ready to use low modulus silicone oxime sealant, specially formulated for the glazing and weather sealing of all types of windows (PVC, Aluminium, lacquered aluminium, wood). The product offers durable adhesion to most porous and non porous substrates including masonry, ceramics bricks, aluminium, metals, PVC, polyacrylate, polycarbonate, impregnated, varnished or painted wood, glass and glazed surfaces.

It cures at room temperature, under the action of atmospheric moisture, to give a flexible and strong seal with low modulus of elasticity.

### Characteristics

- The Neutral Silicone Premium exhibits outstanding primerless adhesion to most substrates used in sanitary and kitchen areas, e.g. glass, tiles, ceramics, enamel, glazed tiles and clinker, aluminium, steel, zinc, copper, impregnable, varnished or painted wood, concrete, PVC and many plastics;
- No volume shrinkage after cure;
- High fungal resistant;
- Almost odourless;
- Flexible at low (-40°C) and high temperatures (+150°C);
- Shelf Life: 12 months.

Silicóne Neutre est un produit mono-composant neutre, prêt à appliquer, de bas module de base oxime. Ce silicone a été conçu pour le collage et l'étanchéité de tous les types de châssis (PVC, Aluminium, Aluminium laqué, Bois). Le produit assure une adhésion durable sur la plupart des substrats poreux et non poreux, y compris la maçonnerie, les briques céramiques, aluminiums, métaux, PVC, polyacrylates, polycarbonates, bois vernis ou teinté, vitres et surfaces vitrifiées. Le Silicóne Neutre Premium durcit à la température ambiante au contact de l'humidité de l'air, assurant une étanchéité forte et flexible de bas module d'élasticité.

### Caractéristiques

- Le Silicóne Neutre Premium a une excellente adhésion sans primaire dans la plupart des supports utilisés dans les espaces sanitaires, comme le verre, la brique, la céramique, les anodisés, les laqués, les métaux (aluminium, zinc, acier, et cuivre), le béton, le bois peint ou vernis, le PVC et des plastiques divers;
- Il n'y a pas de contraction de volume après durcissement;
- Fortes propriétés antifongiques;
- Presque inodore;
- Non corrosif pour les métaux;
- Flexible à basses (-40°C) et hautes températures (+150°C);
- Validité: 12 mois.

La Silicona Neutra es un producto monocomponente de cura neutra, listo para aplicar, de bajo módulo y base oxime. Esta Silicona fue concebida para el sellado de todo tipo de marcos (PVC, aluminio, aluminio lacado, madera). El producto garantiza una adhesión duradera en la mayoría de los materiales porosos y no porosos, incluyendo mampostería, ladrillos cerámicos, aluminios, metales, PVC, poliacrilato, policarbonato, madera barnizada o pintada, vidrio y superficies vitrificadas.

La Silicona Neutra Premium cura a la temperatura ambiente, en contacto con la humedad del aire, garantizando un sellado fuerte y flexible con bajo módulo de elasticidad.

### Características

- La Silicona Neutra Premium tiene una excelente adherencia sin imprimación en la mayoría de los materiales utilizados en áreas sanitarias, tales como vidrio, ladrillo, cerámica, anodizados, lacados, metales (aluminio, zinc, acero y cobre), hormigón, madera pintada o barnizada, PVC y varios plásticos;
- No tiene contracción de volumen tras la cura;
- Fuerte acción fungicida;
- Casi inodora;
- No corrosiva para metales
- Flexible a bajas (-40°C) y altas temperaturas (+150°C);
- Caducidad: 12 meses.



CÓDIGO CODE / CODE / CÓDIGO	COR** COLOR / COULEUR / COLOR	CAPACIDADE CAPACITY / CAPACITÄT	EMBALAGEM QUANTITY / EMBALLAGE / EMBALAJE	QTD. Palete PALET / QT. PALETTE / CANT. PALÉ		
002000000011	Branco / White / Blanc / Blanco	9003	310 ml	25	1200	
002000000012	Branco Brilhante / White Bright / Blanc Brillant / Bianco Brillante	9003	310 ml	25	1200	
002000000022	Transparente / Transparent / Transparent / Transparente		310 ml	25	1200	
002000000055	Preto / Black / Noir / Negro	9005	310 ml	12	1200	
002000000088	Cinza / Grey / Gris / Gris	7011	310 ml	12	1200	
002000000188	Cinza / Grey / Gris / Gris	7016	310 ml	12	1200	
002000000066	Cinza / Grey / Gris / Gris	7037	310 ml	12	1200	
002000000201	Cinza / Grey / Gris / Gris	7004	310 ml	12	1200	
002000000077	Alumínio / Aluminium / Aluminium / Aluminio	9007	310 ml	12	1200	
002000000144	Crema / Light ivory / Ivoire clair / Marfil claro	1015	310 ml	12	1200	
002000000099	Champanhe / Champagne / Champagne / Champán	7048	310 ml	12	1200	
002000000200	Bronze / Bronze / Bronze / Bronce	8019	310 ml	12	1200	
002000000111	Carvalho / Oak / Chêne / Roble	1011	310 ml	12	1200	
002000000199	Nogueira / Fawn brown / Brun fauve / Pardo corzo	8007	310 ml	12	1200	
002000000155	Castanho / Sepia brown / Brun sépia / Sepia	8014	310 ml	12	1200	
002000000133	Bordeaux / Wine red / Rouge vin / Rojo vino	3005	310 ml	12	1200	
002000000033	Verde / Green / Vert / Verde	6005	310 ml	12	1200	
FOIL	002040000011	Branco / White / Blanc / Blanco	9003	300 ml	30	1440
FOIL	002040000022	Transparente / Transparent / Transparent / Transparente		300 ml	30	1440
FOIL	002030000011	Branco / White / Blanc / Blanco	9003	600 ml	18	720
FOIL	002030000022	Transparente / Transparent / Transparent / Transparente		600 ml	18	720



Disponível em / Available in / disponible en / Disponible





# Silicone Neutro Special

Neutral Silicone Special / Silicone Neutre Special / Silicona Neutra Special

O Silicone Neutro Special é um produto monocomponente, de cura neutra oxime, sem solventes voláteis, de baixo módulo e alta elasticidade. Produto com excelente capacidade de adesão em substratos porosos e não porosos.

O produto vulcaniza à temperatura ambiente, em contacto com o ar e humidade, apresentando uma textura de borracha de silicone, conservando-se permanentemente elástico.

#### Características

- O Silicone Neutro Special tem uma excelente aderência sem primário na maioria dos substratos utilizados em áreas sanitárias, designadamente vidro, tijolo, cerâmica, anodizados, lacados, metais (alumínio, zinco, aço e cobre), betão, madeira pintada ou envernizada, PVC e vários plásticos;
- Não tem contração de volume após a cura;
- Ação fungicida;
- Não corrosivo para metais;
- Flexível a baixas (-40°C) e altas temperaturas (+150°C);
- Validade: 12 meses.



Dados técnicos e ficha de segurança disponível sob pedido.

/ Technical information and safety data sheet available under request / Données techniques et fiche de sécurité disponible sur demande / Datos técnicos y ficha de seguridad disponible bajo pedido  
dep.technico@pecol.pt



Neutral Silicone Special is a one part, oxime neutral curing, low modulus, ready to use silicone. The product has excellent adhesion on porous and non-porous substrates. It cures at room temperature, under the action of atmospheric moisture, to give a permanent flexible silicone rubber.

#### Characteristics

- The Neutral Silicone Special exhibits excellent primerless adhesion to most substrates used in sanitary areas, e.g. glass, tiles, ceramics, enamel, glazed tiles and clinker; aluminum, steel, zinc or copper; impregnable, varnished or painted wood, concrete, PVC and many plastics;
- No volume shrinkage after cure;
- Fungal resistant;
- Non corrosive to metals;
- Flexible at low (-40°C) and high temperatures (+150°C);
- Shelf Life: 12 months.

Le Silicone Neutre Special est un produit mono-composant, neutre, base oxime, sans solvants volatils, de bas module et grande élasticité. Produit avec une excellente capacité d'adhésion sur supports poreux et non poreux. Le produit vulcanise à température ambiante, en contact avec l'air et l'humidité, présentant une texture de caoutchouc de silicone, se conservant constamment élastique.

#### Caractéristiques

- Le Silicone Neutre Special a une excellente capacité d'adhésion sans primaire dans la plupart des supports utilisés dans les espaces sanitaires, tels que le verre, la brique, la céramique, les anodisés, les laqués, les métaux (aluminium, zinc, acier et cuivre), béton, bois coloré ou vernis, PVC et plusieurs plastiques;
- Ne change pas de volume après durcissement;
- Action fongicide;
- Non corrosif pour métaux;
- Flexible à basses (-40°C) et hautes températures (+150°C);
- Validité: 12 mois.

La Silicona Neutra Special es un producto monocomponente, de cura neutra oxime, sin solventes volátiles, de bajo módulo y alta elasticidad. Producto con excelente capacidad de adhesión en sustratos porosos y no porosos.

El producto vulcaniza a temperatura ambiente, en contacto con el aire y humedad, presentando una textura de goma de silicona, conservándose permanentemente elástico.

#### Características

- La Silicona Neutra Special tiene una excelente adherencia sin primario en la mayoría de los sustratos utilizados en áreas sanitarias, tales como vidrio, ladrillo, cerámica, anodizados, lacados, metales (aluminio, zinc, acero y cobre), hormigón, madera pintada o embarnizada, PVC y varios plásticos;
- No tiene contracción de volumen tras la cura;
- Acción fungicida;
- No corrosivo para metales
- Flexible a bajas (-40°C) y altas temperaturas (+150°C);
- Validez: 12 meses.

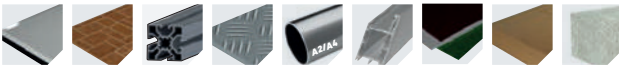

CÓDIGO CODE / CODE / CÓDIGO	COR** COLOR / COULEUR / COLOR	CAPACIDADE CAPACITY / CAPACITÉ / CAPACIDAD	EMBALAGEM QUANTITY / EMBALLAGE / EMBALAJE	QTD. Palete PALET / QT. PALETTE / CANT. PALÉ		
002006000000	Branco / White / Blanc / Blanco	9003	310 ml	25	1200	
002006000001	Branco Brilhante / White Bright / Blanc Brillant / Blanco Brillante	9003	310 ml	12	1200	
002010000000	Transparente / Transparent / Transparent / Transparente		310 ml	25	1200	
002020000000	Preto / Black / Noir / Negro	9011	310 ml	12	1200	
002020000099	Cinza / Grey / Gris / Gris	7011	310 ml	12	1200	
002020000033	Cinza / Grey / Gris / Gris	7037	310 ml	12	1200	
002020000089	Cinza / Grey / Gris / Gris	7004	310 ml	12	1200	
002020000100	Creme / Light ivory /Ivoire clair / Marfil claro	1015	310 ml	12	1200	
002020000111	Champanhe / Champagne / Champanhe / Champán	7048	310 ml	12	1200	
002020000055	Castanho / Sepia brown / Brun sépia / Sepia	8014	310 ml	12	1200	
002016000000	Verde / Green / Vert / Verde	6005	310 ml	12	1200	
002010000002	Branco / White / Blanc / Blanco	9003	300 ml	30	1440	FOIL
002010000001	Transparente / Transparent / Transparent / Transparente		300 ml	30	1440	FOIL
000000726205	Branco / White / Blanc / Blanco	9003	600 ml	18	720	FOIL
000000726204	Transparente / Transparent / Transparent / Transparente		600 ml	18	720	FOIL

\*\* Color del producto aproximada al color RAL / The color of the product is close to color RAL / Couleur du produit similaire a couleur RAL / Cor do produto aproximado a cor RAL

Disponível em  
/ Available in / disponible en  
/ Disponible

**PECOL**<sup>®</sup>  
ECO SYSTEM





# VEDAÇÃO E COLAGEM

Sealing and Bonding / Étanche et Collage / Sellado y Pegado

## Silicone Neutro Sanitários

Neutral Sanitary Silicone / Silicone Neutre Sanitaires / Silicona Neutra Sanitarios



Silicone mono componente de baixo módulo e cura neutra, pronto a aplicar, que vulcaniza em contacto com a atmosfera. Forma uma junta tipo borracha de elevada elasticidade e possui excelente resistência contra a luz solar, à radiação U.V. Possui uma forte ação fungicida, evitando a formação de fungos nas zonas húmidas. O Silicone Neutro Sanitários garante uma boa durabilidade da vedação ao longo dos anos.

### Características

- Excelente adesão na maioria dos materiais sanitários, como por exemplo vidro, azulejo, cerâmica, esmaltes, azulejos vidrados, tijolo, alumínio, plásticos, madeira pintada, envernizada ou impregnada, sem ser necessário o recurso a primário. No entanto a adesão a esses substratos pode ser melhorada caso se recorra ao uso de primários para preparação dos substratos;
- Formação de película rápida;
- Contém fungicida;
- Isento de solventes, o que proporciona uma vulcanização sem perdas de volume;
- Flexível a baixa temperatura (-50°C) e a alta temperatura (+100°C);
- Baixo módulo e melhor adesão;
- Cores disponíveis: Branco RAL9003 e Transparente;
- Validade: 18 meses.

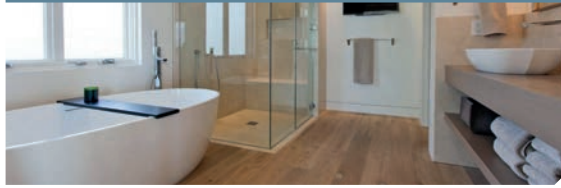

Dados técnicos e ficha de segurança disponível sob pedido.

/ Technical information and safety data sheet available under request / Données techniques et fiche de sécurité disponible sur demande / Datos técnicos y ficha de seguridad disponible bajo pedido  
dep.tecnico@pecol.pt

Single-component, low modulus and neutral cure silicone, ready to use, which cures in contact with the atmosphere. Forms a rubber joint type of high elasticity and has excellent resistance to sunlight, to UV radiation. It has a strong fungicidal action, preventing the formation of fungi in wet areas. Silicona Neutra Sanitarios ensures good durability of the seal over the years.

### Characteristics

- The product exhibits excellent primerless adhesion to most materials used for sanitary application, e.g. glass, tiles, ceramics, enamel, glazed tiles, clinker, aluminium, impregnable, varnished or painted wood and some plastics. The adhesion can be improved in many cases by pretreatment of the substrates with a primer;
- Quickly becomes tack free;
- Contains fungicide;
- Solvent free, no volume shrinkage during vulcanization;
- Flexible at low (-50°C) and high (+100°C) temperatures;
- Low modulus. Better adhesion;
- Available colors: signal white RAL9003 and transparent;
- Extra long shelf life: 18 months.

Le silicone neutre sanitaires est un produit mono-composant de bas module et cure neutre, prêt à appliquer, que vulcanise en contact avec l'atmosphère. Il forme un joint genre caoutchouc de grand élasticité et à une excellent résistance à la lumière du jour et aux rayons UV. Ce produit a une fort action fungicide et évite la formation de moisissures en zones humides. Le silicone neutre sanitaires assure une bonne étanchéité au long des années.

### Caractéristiques

- Excellent adhésion dans la majorité des matériaux sanitaires, comme par exemple le verre, faïence, céramique, fonte émaillée, faïence vitrée, brique, aluminium, plastiques et bois peint, avec vernis ou imprégnés, sans qu'il soit nécessaire l'application d'un primaire. Par contre l'adhésion a ses substrats peut être amélioré avec l'utilisation d'un primaire.
- Formation rapide de pellicule;
- Contient des fungicide;
- Sans solvant, ce qu'implique une vulcanisation sans perte de volume;
- Flexible à basse température (-50°C) et haute température (+100°C);
- Bas module et une meilleure adhérence;
- Couleurs disponibles: Blanc RAL9003 et transparente;
- Validité: 18 mois.

Silicona mono componente de bajo módulo y curado neutro, rápido de aplicar, que vulcaniza en contacto con la atmosfera. Forma una junta tipo goma de elevada elasticidad y posee una excelente resistencia a luz solar, y a la radiación U.V. Posee una fuerte acción fungicida, evitando la formación de hongos en las zonas húmedas.

La Silicona Neutra Sanitarios garantiza una buena durabilidad de la junta a lo largo de los años.

### Características

- Excelente adhesión en la mayoría de los materiales sanitarios, como por ejemplo vidrio, azulejo, cerámica, esmaltes, azulejos vidrados, teja, aluminio, plásticos, madera pintada, barnizada o impregnada, sin ser necesario emplear imprimación. No obstante la adhesión a esos materiales puede ser mejorada cuando se empleen imprimaciones para la preparación de los materiales;
- Formación de película rápida;
- Contiene fungicida;
- Exento de solventes, lo que proporciona una vulcanización sin pérdidas de volumen;
- Flexible a baja temperatura (-50°C) y a alta temperatura (+100°C);
- Bajo módulo y mejor adhesión;
- Colores disponibles: Blanco RAL9003 y transparente;
- Caducidad: 18 meses.



CÓDIGO CODE / CODE / CÓDIGO	COR** COLOR / COULEUR / COLOR	CAPACIDADE CAPACITY / CAPACITÉ / CAPACIDAD	EMBALAGEM QUANTITY / EMBALLAGE / EMBALAJE	QTD. Palete PALET / QT. PALETTE / CANT. PALÉ	
002000000031	Branco / White / Blanc / Blanco	9003	310 ml	25	1200
002000000030	Transparente / Transparent / Transparent / Transparente		310 ml	25	1200

\*\* Cor do produto aproximada à cor RAL / The color of the product is close to color RAL / Couleur du produit similaire à couleur RAL / Color del producto aproximada al color RAL



# Silicone Neutro Construção

Neutral Silicone Building Sealant / Silicone de Construction Neutre / Silicona Neutra Construcción

O Silicone Neutro Construção é um produto monocomponente que cura na presença da humidade atmosférica, criando uma junta de dilatação duradoura, flexível e de baixo módulo.

Graças ao baixo módulo, elevado alongamento, capacidade de recuperação (compressão/dilatação) e à sua capacidade de formar fortes e duradouras ligações entre a maioria dos materiais, este silicone apresenta elevados níveis de performance, mesmo em construções cujas juntas estejam sujeitas a movimentações extremas.

#### Características

- Não se altera quando exposto a raios solares, chuva, granizo, neve, radiações U.V. e temperaturas extremas;
- Não contém PCBs nem amianto. Além disso tem um teor muito baixo de COV;
- É um produto de baixo módulo. Por essa razão, a junta não é submetida a elevados esforços de tensão;
- Quando aplicado segundo as instruções de uso, este Silicone Neutro de Construção revela uma capacidade de até 50% de movimentação da junta em relação à largura da junta original/inicial, sem afetar a integridade do produto;
- Quando curado, permanece em forma de borracha mesmo quando sujeito a temperaturas extremas. Praticamente não sofre alterações com o decorrer do tempo.



Dados técnicos e ficha de segurança disponível sob pedido.

/ Technical information and safety data sheet available under request / Données techniques et fiche de sécurité disponible sur demande / Datos técnicos y ficha de seguridad disponible bajo pedido  
dep.tecnico@pecol.pt



Pecol Neutral Silicone Building Sealant is a one part silicone formulation that cures in the presence of atmospheric moisture to produce a durable, flexible and low modulus silicone rubber building joint seal. Because of his low modulus, high elongation, compression/extension recovery capacity, and his ability to form strong, durable bonds with most building materials, this silicone provides excellent performance, even in building joints that experience extreme movement.

#### Characteristics

- Is virtually unaffected by sunlight, rain, sleet, snows, ultraviolet radiation and extreme temperatures;
- It does not contain PCBs or asbestos. Additionally has a very low VOC contents;
- It's a low modulus material; therefore, joint movement places only a low stress on the sealant/substrate bond line. The material also shows good recovery from extension and compression;
- When applied according to the instructions, this material typically provides joints that can be compressed up to 50 percent of original joint width without affecting the integrity of the seal or bond;
- Cured sealant stays rubbery during temperature extremes normally experienced on buildings without tearing, cracking or becoming brittle. It is virtually unaffected by time or the elements.

Le Silicone de Construction Neutre est un produit mono-composant, de bas module, qui durcit au contact de l'humidité de l'air, présentant une texture de caoutchouc pour une étanchéité de joints de construction s durable et flexible. Dû à son bas module, allongement élevé, récupération d'extension et capacité à former des joints résistants et durables sur la plupart des matériaux, ce Silicone offre une excellente performance même dans les joints soumis à des mouvements extrêmes.

#### Caractéristiques

- N'est pratiquement pas affecté par le soleil, pluie, givre, neige, rayons U.V. et températures extrêmes;
- Ne contient pas de PCB ou amiante. A une très faible teneur en COV;
- À bas module, par conséquent, le mouvement des joints n'affecte pratiquement pas la liaison mastic/support. Il présente également une bonne récupération d'extension et compression;
- Offre généralement des joints qui peuvent être compressés jusqu'à 50 pour cent de la largeur du joint d'origine sans affecter l'intégrité du mastic ou liaison, quand il est appliqué selon les instructions;
- Devient caoutchouteux quand il durcit et résiste à de hautes températures habituellement rencontrées sur les bâtiments sans se déchirer, fissurer ou casser. Il est peu affecté par le temps et les intempéries.

La Silicona Neutra Construcción es un producto monocomponente que cura en presencia de la humedad atmosférica, creando una junta de dilatación duradera, flexible y de bajo módulo. Gracias al bajo módulo, elevado alargamiento, capacidad de recuperación (compresión/dilatación) y a su capacidad de formar fuertes y duraderas conexiones entre la mayoría de los materiales, esta silicona presenta unos elevados niveles de prestación, incluso en construcciones cuyas juntas estén sujetas a movilizaciones extremas.

#### Características

- No se altera cuando es expuesta a rayos solares, lluvia, granizo, nieve, radiaciones U.V. y temperaturas extremas;
- No contiene PCBs ni amianto. Además tiene un grado muy bajo de COV;
- Es un producto de bajo módulo. Por ese motivo, la junta no está sometida a elevados esfuerzos de tensión;
- Cuando es aplicada según las instrucciones de uso, esta Silicona Neutra de Construcción revela una capacidad de hasta 50% de movilización de la junta en relación al ancho de la junta original/ inicial, sin afectar la integridad del producto;
- Cuando curada, permanece en forma de caucho incluso cuando es sometida a temperaturas extremas. Prácticamente no sufre alteraciones con el paso del tiempo.

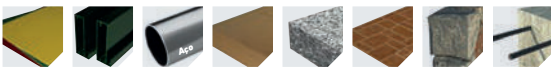

CÓDIGO CODE / CODE / CÓDIGO	COR** COLOR / COULEUR / COLOR	CAPACIDADE CAPACITY / CAPACITÉ / CAPACIDAD	EMBALLAGEM QUANTITY / EMBALLAGE / EMBALAJE	QTD. Palette PALET / QT. PALETTE / CANT. PALÉ	
002901000000	Branco / White / Blanc / Blanco	9003	310 ml	25	1200
002902000000	Cinza / Grey / Gris / Gris	7035	310 ml	25	1200

\*\* Cor do produto aproximada à cor RAL / The color of the product is close to color RAL / Couleur du produit similaire à couleur RAL / Color del producto aproximada al color RAL





# VEDAÇÃO E COLAGEM

Sealing and Bonding / Étanche et Collage / Sellado y Pegado

## Silicone Neutro Altas Temperaturas

High Temperature Neutral Silicone Sealant / Silicone Neutre Hautes Températures / Silicona Neutra Altas Temperaturas



Silicone neutro monocomponente, para juntas de vedação e selagens a elevadas temperaturas até +250°C. Cura à temperatura ambiente sob a ação da humidade atmosférica, conferindo uma flexibilidade permanente ao cordão de silicone.

### Características

- Flexível a baixas (-40°C) e altas temperaturas (+250°C);
- Mantém as propriedades elásticas com temperaturas constantes até +250°C e por um curto período de tempo com temperaturas de +300°C;
- Boa resistência química;
- Boa estabilidade aos raios U.V.;
- Boa adesão em aço, alumínio, vidro, cerâmica, telha e na maioria dos plásticos;
- Cor: preto;
- Validade: 12 meses.



Dados técnicos e ficha de segurança disponível sob pedido.

/ Technical information and safety data sheet available under request / Données techniques et fiche de sécurité disponible sur demande / Datos técnicos y ficha de seguridad disponible bajo pedido  
dep.tecnico@pecol.pt

One component, Neutral curing silicone sealant, for general purpose sealing in high temperature applications up to +250°C. It cures at room temperature under the action of atmospheric moisture to give a permanent flexible silicone rubber.

### Characteristics

- Flexible at low (-40°C) and high temperatures (+250°C)
- Maintains elastic properties at continuous temperatures of up to +250°C and short term up to +300°C;
- Good chemical resistance;
- Very good U.V. stability;
- Very good adhesion on steel, aluminium, glass, ceramic, ceramic tiles and many plastics;
- Color: Black;
- Shelf Life: 12 months.

C'est un Silicone Neutre mono-composant, pour les jointes d'étanchéité à hautes températures jusqu'à +250°C. Il durcit à température ambiante, sous l'action de l'humidité atmosphérique, donnant une flexibilité permanente au cordon de silicone.

### Caractéristiques

- Flexible à basses (-40°C) et hautes (+250°C) températures;
- Préserve les propriétés élastiques avec des températures constantes jusqu'à +250°C et durant une courte période avec une température de +300°C;
- Bonne résistance chimique;
- Bonne stabilité aux rayons U.V.;
- Bonne adhésion sur acier, aluminium, verre, céramique, et sur la plupart des plastiques;
- Couleur: Noir;
- Validité: 12 mois.

Silicona Neutra monocomponente, para juntas de sellado a elevadas temperaturas hasta +250°C. Cura a temperatura ambiente bajo la acción de la humedad atmosférica, proporcionándole una flexibilidad permanente al cordón de silicona.

### Características

- Flexible a bajas (-40°C) y altas temperaturas (+250°C);
- Mantiene las propiedades elásticas con temperaturas constantes hasta +250°C y por un corto periodo de tiempo con temperaturas de +300°C;
- Buena resistencia química;
- Buena estabilidad a los rayos U.V.;
- Buena adhesión en acero, aluminio, vidrio, cerámica, teja y en la mayoría de los plásticos;
- Color: negro;
- Caducidad: 12 meses.



CÓDIGO CODE / CODE / CÓDIGO	COR** COLOR / COULEUR / COLOR	CAPACIDADE CAPACITY / CAPACITÉ / CAPACIDAD	EMBALAGEM QUANTITY / EMBALLAGE / EMBALAJE	QTD. Paleta PALET / QT. PALETTE / CANT. PALÉ
002803000000	Preto / Dark / Noir / Negra	9011 310 ml	25	1200

\*\* Cor do produto aproximada à cor RAL / The color of the product is close to color RAL / Couleur du produit similaire à couleur RAL / Color del producto aproximada al color RAL



# Silicone Altas Temperaturas Aerosol

High Temperature Silicone Sealant Aerosol / Silicone Hautes Températures Aérosol / Silicona Altas Temperaturas Aerosol

Silicone Neutro Oxime monocomponente para vedações e selagens em juntas sujeitas a elevadas temperaturas. Indicado para colagem e selagem em locais que exijam uma grande resistência a óleos e gorduras. Boa adesão em aço, alumínio, vidro, cerâmica e muitos outros materiais. Cura à temperatura ambiente sob a ação da humidade atmosférica conferindo uma flexibilidade permanente ao cordão de silicone.

#### Características

- Resiste a altas temperaturas até +250°C;
- Excelente resistência a óleo, gorduras e temperatura;
- Boa resistência à pressão;
- Enchimento de juntas, fácil e perfeito;
- Boa resistência ao envelhecimento;
- Cor: preto;
- Disponível numa embalagem de 200 ml que funciona com uma ponta aplicadora sob pressão e de fácil uso. Não necessita de usar pistola de silicone.

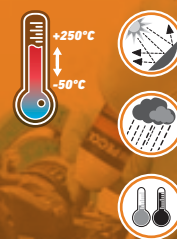
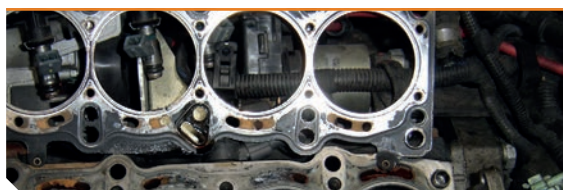
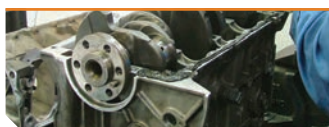

Dados técnicos e ficha de segurança disponível sob pedido.

/ Technical information and safety data sheet available under request / Données techniques et fiche de sécurité disponible sur demande / Datos técnicos y ficha de seguridad disponible bajo pedido  
dep.tecnico@pecol.pt

One component, neutral curing silicone, general purpose sealing in high temperature applications. Suitable for adhesive bonding and sealing for which an especially high level of oil and grease resistance is required. Very good adhesion on steel, aluminium, glass, ceramic and many other materials. It cures at room temperature under the action of atmospheric moisture to give a permanent flexible silicone rubber.

#### Characteristics

- High temperature resistance up to +250°C;
- Excellent resistance to oil, grease and temperature;
- Good pressure resistance;
- Controlled swelling;
- Very good U.V. stability;
- Good resistance to aging;
- Color: Black;
- Available in a practical press pack (200ml). No caulking gun is required for processing this variant.

Le Silicone neutre mono-composant pour étanchéité et scellage dans des jointes soumises à des hautes températures. Indiqué pour coller et sceller dans des emplacements qui exigent une grande résistance aux huiles et graisses. Bonne adhésion à l'acier, aluminium, verre, céramique et plusieurs autres matériaux. Durcit à température ambiante sous l'action de l'humidité atmosphérique attribuant une flexibilité permanente au cordon de silicone.

#### Caractéristiques

- Résistance à hautes températures jusqu'à +250°C;
- Excellente résistance à l'huile, graisses, et température;
- Bonne résistance à la pression;
- Remplissage de jointes facile et parfait;
- Bonne résistance au vieillissement;
- Couleur: noir;
- Disponible en emballage de 200ml qui fonctionne avec une pointe d'application sous pression et de facile utilisation. Ne nécessite pas d'utilisation d'un pistolet à mastic.

Silicona neutra monocomponente para sellados en juntas sujetas a elevadas temperaturas. Indicado para pegado y sellado en lugares que exijan una gran resistencia a aceites y grasas. Buena adhesión en acero, aluminio, vidrio, cerámica y muchos otros materiales. Cura a temperatura ambiente bajo la acción de la humedad atmosférica proporcionando una flexibilidad permanente al cordón de silicona.

#### Características

- Resistente a altas temperaturas hasta +250°C;
- Excelente resistencia a aceites, grasas y temperatura;
- Buena resistencia a la presión;
- Relleno de juntas fácil y perfecto;
- Buena resistencia al envejecimiento;
- Color: Negro;
- Disponible en un embalaje de 200ml que funciona con una cánula aplicadora bajo presión y de fácil uso. No necesita usar pistola de silicona.

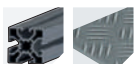

**CÓDIGO**  
CODE / CODE /  
CÓDIGO

**COR\*\***  
COLOR / COULEUR / COLOR

**CAPACIDADE**  
CAPACITY /  
CAPACITÉ /  
CAPACIDAD

**EMBALAGEM**  
QUANTITY /  
EMBALLAGE /  
EMBALAJE

**QTD. Palete**  
PALET /  
QT. PALETTE /  
CANT. PALÉ

00280400000

Preto / Dark / Noir / Negra

200 ml

6

-

\*\* Cor do produto aproximada à cor RAL / The color of the product is close to color RAL / Couleur du produit similaire à couleur RAL / Color del producto aproximada al color RAL





# VEDAÇÃO E COLAGEM

Sealing and Bonding / Étanche et Collage / Sellado y Pegado

## Silicone Acetato Premium

Acetoxi Silicone Premium / Silicón Acético Premium / Silicón Acetato Premium



O Silicone Acetato Premium é um produto mono componente, de baixo módulo, sem solventes voláteis que vulcaniza em contacto com o ar e humidade, criando uma película resistente e de elevada elasticidade. O produto depois de seco, proporciona juntas flexíveis que garantem um excelente isolamento contra a chuva, neve, raios UV, temperaturas conservando-se com elasticidade permanente.

### Características

- Excelente aderência sem primário na maioria das aplicações sanitárias, tais como em vidro, azulejo, cerâmica, esmalte, alumínio, madeira envernizada ou pintada e vários plásticos. Em algumas situações, a adesão pode ser melhorada, utilizando um primário no substrato;
- Rápida formação de película;
- Isento de solventes, sem contração de volume depois de seco;
- Baixo módulo, alta elasticidade;
- Flexível a baixas (-40°C) e altas temperaturas (+180°C);
- Prazo de validade alargado: 24 meses



Dados técnicos e ficha de segurança disponível sob pedido.

/ Technical information and safety data sheet available under request / Données techniques et fiche de sécurité disponible sur demande / Datos técnicos y ficha de seguridad disponible bajo pedido

dep.technico@pecol.pt

One Component, low modulus acetoxi silicone, which cures with atmospheric moisture to form a rubber like seal, for glazing applications, joint sealing and assembly. Weathering and UV resistance are excellent. The product is unaffected by high or low temperature and its physical properties are designed to give outstanding durability and performance. The product is mold and mildew resistant.

### Characteristics

- The product exhibits excellent primerless adhesion to most materials used for sanitary application, e.g., glass, tiles, ceramics, enamel, glazed tiles, clinker, aluminum, impregnable, varnished or painted wood and some plastics. The adhesion can be improved in many cases by pretreatment of the substrates with a primer;
- Quickly becomes tack free;
- Contains fungicide;
- Solvent free, and low shrinkage during vulcanization;
- Flexible at low (-40°C) and high (+180°C) temperatures;
- Low modulus. Better adhesion;
- Extra long shelf life: 18 months.

Silicón Acético Premium est un produit mono-composant, bas module, sans solvants volatils qui vulcanise en contact avec l'humidité de l'air, créant une pellicule résistante et d'une grande élasticité. Le produit une fois sec fournit des joints flexibles qui assurent un excellent isolement contre la pluie, la neige, les rayons UV., la température en gardant une élasticité permanente.

### Caractéristiques

- Excellente adhérence sans primaire sur la plupart des applications sanitaires telles que le verre, le carrelage, la céramique, l'émail, l'aluminium, le bois peint ou vernis et des plastiques divers. Dans certaines situations, l'adhésion peut être améliorée en utilisant un primaire;
- Rapide formation d'une pellicule;
- Sans solvant, sans contraction du volume après séchage;
- Bas module, grande élasticité;
- Flexible à basse (-40°C) et haute (+180°C) températures;
- Duré de stockage: 18 mois.

La Silicón Acetato Premium es un producto monocomponente, de bajo módulo, sin solventes volátiles que vulcaniza en contacto con el aire y humedad, creando una película resistente y de elevada elasticidad. El producto, una vez seco, proporciona juntas flexibles que garantizan un excelente aislamiento contra la lluvia, nieve, rayos UV., temperaturas conservándose con elasticidad permanente.

### Características

- Excelente adherencia sin imprimación en la mayoría de las aplicaciones sanitarias, tales como vidrio, azulejo, cerámica, esmalte, aluminio, madera barnizada o pintada y diferentes plásticos. En algunas situaciones, la adherencia puede ser mejorada, utilizando un imprimación en el material;
- Rápida formación de película;
- Exento de solventes, sin contracción de volumen una vez seco;
- Bajo módulo, alta elasticidad;
- Flexible a bajas (-40°C) y altas temperaturas (+180°C);
- Fecha de caducidad prolongada: 24 meses



CÓDIGO CODE / CODE / CÓDIGO	COR** COLOR / COULEUR / COLOR	CAPACIDADE CAPACITY / CAPACITÉ / CAPACIDAD	EMBALAGEM QUANTITY / EMBALLAGE / EMBALAJE	QTD. Palete PALET / QT. PALETTE / CANT. PALÉ	
002018100001	Branco / White / Blanc / Blanco	9003	310 ml	25	1200
002018100000	Transparente / Transparent / Transparent / Transparente		310 ml	25	1200
002018100003	Preto / Black / Noir / Negro	9011	310 ml	12	1200
002018100013	Cinza / Grey / Gris / Gris	7011	310 ml	12	1200
002018100017	Cinza / Grey / Gris / Gris	7016	310 ml	12	1200
002018100004	Cinza / Grey / Gris / Gris	7037	310 ml	12	1200
002018100005	Alumínio / Aluminium / Aluminium / Aluminio	9007	310 ml	12	1200
002018100009	Creme / Light ivory / Ivoire clair / Marfil claro	1015	310 ml	12	1200
002018100006	Champanhe / Champagne / Champagne / Champán	7048	310 ml	12	1200
002018100008	Bronze / Bronze / Bronze / Bronze	8019	310 ml	12	1200
002018100015	Carvalho / Oak / Chêne / Roble	1011	310 ml	12	1200
002018100018	Nogueira / Fawn brown / Brun fauve / Pardo corzo	8007	310 ml	12	1200
002018100007	Castanho / Sepia brown / Brun sépia / Sepia	8014	310 ml	12	1200
002018100010	Bordeaux / Wine red / Rouge vin / Rojo vino	3005	310 ml	12	1200
002018100012	Vermelho / Red / Rouge / Rojo	3003	310 ml	12	1200
002018100002	Verde / Green / Vert / Verde	6005	310 ml	12	1200
002018100022	Verde / Green / Vert / Verde	6200	310 ml	12	1200
002018100011	Azul / Blue / Bleu / Azul	5005	310 ml	12	1200
FOIL 002018400001	Branco / White / Blanc / Blanco	9003	300 ml	30	1440
FOIL 002018400000	Transparente / Transparent / Transparent / Transparente		300 ml	30	1440
FOIL 002018300001	Branco / White / Blanc / Blanco	9003	600 ml	18	720
FOIL 002018300000	Transparente / Transparent / Transparent / Transparente		600 ml	18	720

\*\* Cor do produto aproximada à cor RAL / The color of the product is close to color RAL / Couleur du produit similaire à couleur RAL / Color del producto aproximada al color RAL







# Silicone Acetato Special

Acetoxy Silicone Special / Silicone Acétique Special / Silicona Acetato Special

O Silicone Acetato Special é um produto mono componente de cura acética, adequado para o uso geral e aplicações sanitárias. O Silicone cura à temperatura ambiente, em contacto com a humidade do ar, formando um cordão tipo borracha para aplicações profissionais em vidros, selagem de juntas e montagens. A resistência deste Silicone à intempérie e aos raios U.V. é excelente, e pode ser utilizado em ambientes húmidos.

### Características

- O Silicone Acetato Special tem um excelente poder de adesão inicial na maioria dos materiais utilizados nas aplicações sanitárias, designadamente vidros, azulejos, cerâmicas, esmaltes, tijolos envidraçados, madeiras envernizadas ou pintadas e algum tipo de plásticos;
- Ação Fungicida;
- Flexível a baixas (-40°C) e altas (+150°C) temperaturas;
- Rápida formação de película;
- Excelentes propriedades de manuseamento, no uso profissional;
- Baixo módulo;
- Validade extensa: 18 meses.



Dados técnicos e ficha de segurança disponível sob pedido.

/ Technical information and safety data sheet available under request / Données techniques et fiche de sécurité disponible sur demande / Datos técnicos y ficha de seguridad disponible bajo pedido

dep.technico@pecol.pt

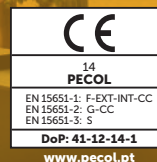
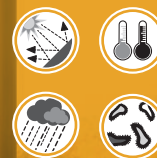

One Component acetoxy curing, silicone sealant for general purpose sealing and sanitary applications. The product cures at room temperature under the action of atmospheric moisture, form a rubber-like seal for specialized glazing applications, joint sealing and assembly. Weathering and UV resistance are excellent. The product is suitable for sanitary applications.

### Characteristics

- Pecol acetoxy special exhibits excellent primerless adhesion to most materials used for sanitary application, e.g., glass, tiles, ceramics, enamel, glazed tiles and clinker, varnished or painted wood and some plastics. The adhesion can be improved in many cases by pretreatment of the substrates with a primer;
- Mold retardant;
- Flexible at low (-40°C) and high (+150°C) temperatures;
- Rapid crosslinking. Rapid becomes tack-free;
- Excellent tooling properties for professional use;
- Low modulus;
- Long shelf life: 18 months.

Le Silicone Acétique Special est un produit mono-composant acétique, adéquat pour une utilisation générale et applications sanitaire. Le Silicone durcit à température ambiante, en contact avec l'humidité de l'air, formant un cordon, genre caoutchouc, pour des applications professionnelles sur verres, scellement de joints et montages. La résistance de ce Silicone aux intempéries et aux rayons U.V. est excellente et il peut être utilisé dans des environnements humides, car il est résistant aux moisissures.

### Caractéristiques

- Le Silicone Acétique Special a un excellent pouvoir d'adhésion sur la plupart des matériaux utilisés dans les applications sanitaires tels que, le verre, carrelage, céramique, émaille, brique en verre, bois vernis ou peint et certains types de plastique;
- Action Fongicide;
- Flexible à basses (-40°C) et hautes températures (+150°C);
- Formation rapide de pellicule;
- Excellentes propriétés de maniement, dans l'usage professionnel;
- Bas module;
- Validité allongée: 18 mois.

La Silicona Acetato Special es un producto monocomponente de cura acética, adecuado para el uso general y aplicaciones sanitarias. La Silicona cura a temperatura ambiente, en contacto con la humedad del aire, formando un cordón tipo goma para aplicaciones profesionales en vidrios, sellado de juntas y montajes. La resistencia de esta Silicona a la intemperie y a los rayos U.V. es excelente, y puede ser utilizada en ambientes húmedos.

### Características

- La Silicona Acetato Special tiene un excelente poder de adhesión inicial en la mayoría de los materiales utilizados en aplicaciones sanitarias, tales como vidrios, azulejos, cerámicas, esmaltes, ladrillos acristalados, maderas barnizadas o pintadas y algunos tipos de plásticos;
- Acción Fungicida;
- Flexible a bajas (-40°C) y altas (+150°C) temperaturas;
- Rápida formación de película;
- Excelentes propiedades de manipulación, en el uso profesional;
- Bajo módulo;
- Caducidad prolongada: 18 meses.

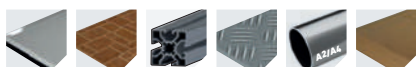

CÓDIGO CODE / CODE / CÓDIGO	COR** COLOR / COULEUR / COLOR		CAPACIDADE CAPACITY / CAPACITÉ / CAPACIDAD	EMBALAGEM QUANTITY / EMBALLAGE / EMBALAJE	QTD. Palete PALET / QT. PALETTE / CANT. PALÉ	
002001000000	Branco / White / Blanc / Blanco	9003	310 ml	25	1200	
002002000000	Transparente / Transparent / Transparent / Transparente		310 ml	25	1200	
002004000000	Preto / Black / Noir / Negro	9011	310 ml	12	1200	
002015000000	Cinza / Grey / Gris / Gris	7011	310 ml	12	1200	
002011000000	Cinza / Grey / Gris / Gris	7037	310 ml	12	1200	
002003000000	Alumínio / Aluminium / Aluminium / Aluminium	9007	310 ml	12	1200	
002020000002	Castanho / Sepia brown / Brun sépia / Sepia	8014	310 ml	12	1200	
002007000000	Verde / Green / Vert / Verde	6005	310 ml	12	1200	
002002200000	Branco / White / Blanc / Blanco	9003	300 ml	30	1440	FOIL
002002100000	Transparente / Transparent / Transparent / Transparente		300 ml	30	1440	FOIL
002002300000	Branco / White / Blanc / Blanco	9003	600 ml	18	720	FOIL
002002400000	Transparente / Transparent / Transparent / Transparente		600 ml	18	720	FOIL

\*\* Cor do produto aproximada à cor RAL / The color of the product is close to color RAL / Couleur du produit similaire a couleur RAL / Color del producto aproximada al color RAL

Disponível  
/ Available in / disponible en  
/ Disponível em

**PECOL**<sup>®</sup>  
ECO SYSTEM





# VEDAÇÃO E COLAGEM

Sealing and Bonding / Étanche et Collage / Sellado y Pegado

## Silicone Acetato Sanitários

Acetoxy Sanitary Silicone / Silicone Acétique Sanitaires / Silicona Acetato Sanitários

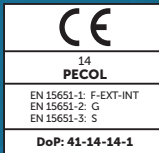

Silicone mono componente de baixo módulo e cura acética, pronto a aplicar, que vulcaniza em contacto com a atmosfera formando uma junta tipo borracha. Este produto está preparado para selar e vedar juntas expostas a um elevado índice de humidade devido à sua elevada ação fungicida e resistência ao bolor. O Silicone Acetato Sanitários não sofre alteração quando sujeito a altas ou baixas temperaturas e as suas propriedades físicas proporcionam uma durabilidade e performance extraordinária.

### Características

- O Silicone Acetato Sanitários tem uma excelente aderência na maioria dos materiais sanitários, como por exemplo vidro, azulejo, cerâmica, esmaltes, azulejos vidrados, tijolo, alumínio, plásticos, madeira pintada, envernizada ou impregnada, sem ser necessário o recurso a primário. No entanto a adesão a esses substratos pode ser melhorada caso se recorra ao uso de primários para preparação dos substratos;
- Formação de película rápida;
- Contém fungicida;
- Isento de solventes, o que proporciona uma vulcanização sem perdas de volume;
- Flexível a baixa temperatura (-40°C) e a alta temperatura (+180°C);
- Baixo módulo e melhor adesão;
- Validade extensa: 24 meses;
- Cores disponíveis: Branco RAL9003 e Transparente.

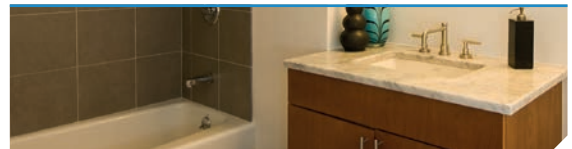

Dados técnicos e ficha de segurança disponível sob pedido.

/ Technical information and safety data sheet available under request / Données techniques et fiche de sécurité disponible sur demande / Datos técnicos y ficha de seguridad disponible bajo pedido  
dep.tecnico@pecol.pt

One Component, low modulus acetoxy curing silicone, ready to use, which cures with atmospheric moisture to form a rubber like seal. The product is specially formulated for glazing and sealing of joints exposed to high levels of moisture due to his very strong mildew resistance. The product is unaffected by high or low temperature and its physical properties are designed to give outstanding durability and performance.

### Characteristics

- The product exhibits excellent primerless adhesion to most materials used for sanitary application, e.g. glass, tiles, ceramics, enamel, glazed tiles, clinker, aluminium, impregnable, varnished or painted wood and some plastics. The adhesion can be improved in many cases by pretreatment of the substrates with a primer;
- Quickly becomes tack free;
- Contains fungicide;
- Solvent free, no volume shrinkage during vulcanization;
- Flexible at low (-40°C) and high (+180°C) temperatures;
- Low modulus. Better adhesion;
- Extra long shelf life: 24 months.

Le Silicone Acétique Sanitaires est un produit mono-composant acétique de bas module, prêt à utiliser, qui vulcanise en contact avec l'atmosphère, formant un joint genre caoutchouc. Ce produit est préparé pour étancher et sceller des joints exposés à un indice d'humidité élevé dû à son action fungicide et résistance aux moisissures. Le Silicone Acétique Sanitaires ne souffre pas de modification quand il est soumis à des hautes ou basses températures et ses propriétés physiques lui proportionnant une durabilité et performance extraordinaire.

### Caractéristiques

- Le Silicone Acétique Sanitaires a une excellente adhésion sur la plupart des matériaux tels que, le verre, carrelage, céramique, émaille, brique en verre, aluminium, plastiques, bois vernis ou peint ou imprégnée, sans être nécessaire l'application d'un primaire pour préparer les supports;
- Formation rapide de pellicule;
- Contient des Fongicides;
- Sans solvants, ce qui implique une vulcanisation sans perte de volume;
- Flexible à basses (-40°C) et hautes températures (+180°C);
- Bas module et meilleure adhésion;
- Validité allongée: 24 mois.

Silicona monocomponente de bajo módulo y cura acética, lista para aplicar, que vulcaniza en contacto con la atmósfera formando una junta tipo goma. Este producto está preparado para sellar juntas expuestas a un elevado índice de humedad debido a su elevada acción fungicida y resistencia al moho.

La Silicona Acetato Sanitarios no sufre alteración cuando se somete a altas o bajas temperaturas y sus propiedades físicas proporcionan una durabilidad y prestación extraordinaria.

### Características

- La Silicona Acetato Sanitarios tiene una excelente adhesión en la mayoría de los materiales sanitarios, como por ejemplo vidrio, azulejo, cerámica, esmaltes, azulejos acristalados, ladrillo, aluminio, plásticos, madera pintada, embarnizada o impregnada sin ser necesario recurrir a un primario. Sin embargo la adhesión puede ser mejorada si recurre al uso de primarios para preparación de los sustratos.
- Formación de película rápida;
- Contiene fungicida;
- Exento de solventes, lo que proporciona una vulcanización sin pérdidas de volumen;
- Flexible a baja temperatura (-40°C) y a alta temperatura (+180°C);
- Bajo módulo y mejor adhesión;
- Caducidad prolongada: 24 meses;
- Colores disponibles: Blanco RAL9003 y transparente.



CÓDIGO CODE / CODE / CÓDIGO	COR** COLOR / COULEUR / COLOR	CAPACIDADE CAPACITY / CAPACITÉ / CAPACIDAD	EMBALAGEM QUANTITY / EMBALLAGE / EMBALAJE	QTD. Palete PALET / QT. PALLETTE / CANT. PALÉ
002017000000	Transparente / Transparent / Transparent / Transparente	310 ml	25	1200
002018000000	Branco / White / Blanc / Blanco	9003 310 ml	25	1200

\*\* Cor do produto aproximada à cor RAL / The color of the product is close to color RAL / Couleur du produit similaire a couleur RAL / Color del producto aproximada al color RAL

# Cordão p/ Juntas de Dilatação PE

Polyethylene (PE) Cord / Cordon p/ Joints de Dilatation PE / Cordón p/ Juntas de Dilatación PE

Cordão para juntas de Polietileno, produzido de acordo com a normativa DIN18450 para preenchimento de juntas de expansão. Este cordão é composto por células de espuma de polietileno e é ideal para preencher juntas reduzindo as perdas de calor. O cordão para juntas de dilatação proporciona um preenchimento seguro em juntas de dilatação e tem como vantagem a excelente compatibilidade com a maioria dos materiais usados na selagem e vedação de juntas. Ao usar como enchimento de juntas evita o contacto tripontual.

#### Características

- Cumpre o requisito da normativa DIN18450 para o preenchimento de juntas de dilatação;
- Ideal para juntas sujeitas a humidade;
- Resistente à água e humidade;
- Reduz a profundidade da junta e elimina o contacto tripontual aquando da aplicação de selantes (silicone, cola e veda, selante acrílico,...);
- Flexível e elástico;
- Resiste ao envelhecimento.



Dados técnicos e ficha de segurança disponível sob pedido.

/ Technical information and safety data sheet available under request / Données techniques et fiche de sécurité disponible sur demande / Datos técnicos y ficha de seguridad disponible bajo pedido

dep.tecnico@pecol.pt



PE cord is a round seal, which fulfils the requirements of the DIN 18450 for backfill material on expanding joints. It consists of closed cellular polyethylene foam and is suitable for sealing against drafts and heat loss. PE cord provides a reliable backfill on building joints and is characterized through its excellent compatibility with all standard sealing materials. Used as a backing support for sealants, 3-sided adhesion can be effectively eliminated.

#### Characteristics

- Fulfils the requirement of the DIN 18450 for backfill material on expanding joints;
- Suitable for damp joints;
- Water and moisture resistant;
- Minimizes the joint depth and eliminates the 3-sided adhesion on back filled sealants (silicone, PU, acrylic,...);
- Elastic flexible;
- Ageing resistant.

Cordon pour joints de polyéthylène, produit en accord avec la norme DIN18450 pour le remplissage de joints d'expansion. Ce cordon est composé de cellules de mousse en polyéthylène et est idéale pour remplir des joints réduisant les pertes de chaleur.

Le cordon pour joints de dilatation proportionne le remplissage sûr des joints de dilatation et a comme avantage une excellente compatibilité avec la plupart des matériaux utilisés dans le scellage et étanchéité des joints. En l'utilisant comme rembourrage de joints, il évite le contact tri-punctuel.

#### Characteristics

- Respecte les exigences normatives DIN18450 pour le remplissage de joints de dilatation;
- Idéal pour joints soumis à l'humidité;
- Résistant à l'eau et à l'humidité;
- Réduit la profondeur du joint et élimine le contact tri-punctuel au moment de l'application du scellant (silicone, mastic de PU, mastic acrylique,...);
- Flexible et élastique;
- Résiste au vieillissement.

Cordón para Juntas de Polietileno, fabricado de acuerdo con la normativa DIN18450 para relleno de juntas de expansión. Este cordón está compuesto por células de espuma de polietileno y es ideal para rellenar juntas reduciendo las pérdidas de calor.

El cordón para juntas de dilatación proporciona un relleno seguro en juntas de dilatación y tiene como ventaja la excelente compatibilidad con la mayoría de los materiales usados en el sellado de juntas. Al usar como relleno de juntas evita el contacto tripunctual.

#### Characteristics

- Cumple el requisito de la normativa DIN18450 para el relleno de juntas de dilatación;
- Ideal para juntas sujetas a humedad;
- Resistente al agua y humedad;
- Reduce la profundidad de la junta y elimina el contacto tripunctual en el momento de la aplicación de sellantes (silicona, pega y sella, sellante acrílico,...);
- Flexible y elástico;
- Resistente al envejecimiento.

CÓDIGO CODE / CODE / CÓDIGO	COR COLOR / COULEUR / COLOR	Ø	EMBALLAGEM QUANTITY / EMBALLAGE / EMBALAJE
002109100000	Cinza / Grey / Gris / Gris	10	1150 mts
002109150000	Cinza / Grey / Gris / Gris	15	550 mts
002109200000	Cinza / Grey / Gris / Gris	20	350 mts
002109250000	Cinza / Grey / Gris / Gris	25	200 mts
002109300000	Cinza / Grey / Gris / Gris	30	160 mts
002109400000	Cinza / Grey / Gris / Gris	40	270 mts
002109500000	Cinza / Grey / Gris / Gris	50	84 mts





# VEDAÇÃO E COLAGEM

Sealing and Bonding / Étanche et Collage / Sellado y Pegado

## Cola e Veda Premium

Cola & Veda Premium / Mastic de PU Premium / Pega y Sella Premium



O Cola e Veda Pecol Premium é um mástique mono componente de alto módulo à base de poliuretano que cura em contacto com a humidade do ar, para selagens e colagens elásticas. Adequado para aplicações no exterior e interior.

### Características

- Cola e Veda Premium tem muito boa aderência à maior parte dos substratos usados na construção, tem excelente resistência mecânica, boa consistência e tixotropia;
- Não escorre;
- Pode ser pintado depois de seco. Recomendamos todavia a realização de testes preliminares se utilizar tinta com base em óleos ou revestimentos com grande carga de solventes;
- Inodoro depois de seco;
- Produto não corrosivo;
- Boa resistência às intempéries;
- Boa resistência à água, ácidos fracos, alcalinos fracos, esgotos, óleos minerais, óleos vegetais, gorduras, combustíveis;
- Resistente a temperaturas entre os -40°C e os +90°C;
- Validade: 12 meses.



Dados técnicos e ficha de segurança disponível sob pedido.

/ Technical information and safety data sheet available under request / Données techniques et fiche de sécurité disponible sur demande / Datos técnicos y ficha de seguridad disponible bajo pedido

dep. tecnico@pecol.pt

Cola & Veda Pecol Premium is a one component polyurethane sealant, gun grade, with high modulus, suitable for a wide range of sealing and bonding applications. It cures under the action of atmospheric moisture. Suitable for external and interior application.

### Characteristics

- The Cola & Veda Premium exhibits excellent adhesion on all cement based materials, brick, ceramics, metals, wood, epoxy, polyester and acrylic resin;
- Can be painted over after full cure. Coatings containing solvents such as enamels, oils based or other components may cause the surface of the sealant to react creating a tacky surface. Preliminary tests recommended;
- Non corrosive;
- Good weathering and water resistance;
- Good resistance to water, weak acids, weak alkalis, sewerage, mineral oils, vegetable oils, fats, fuels;
- Temperature resistance from -40°C to +90°C;
- Shelf Life: 12 months.

Le Mastic de PU Premium est un mastic mono-composant à base de polyuréthane qui durcit au contact de l'humidité de l'air, pour scellements et collages élastiques. Adéquats pour des applications en extérieur et intérieur.

### Caractéristiques

- Le Mastic de PU Premium a une très bonne adhésion sur la plupart des support utilisés dans la construction, une excellente résistance mécanique, une bonne consistance et tixotropie;
- Ne coule pas;
- Peut être peint après séchage. Néanmoins, des tests préliminaires sont recommandés dans le cas d'utilisation de peinture à base d'huiles ou revêtement avec une grande charge de solvants;
- Inodore après séchage;
- Produit non corrosif;
- Bonne résistance aux intempéries;
- Bonne résistance à l'eau, acides faibles, alcalins faibles, égouts, huiles minérales, huiles végétales, graisses, combustibles;
- Résistant à des températures comprises entre -40°C et +90°C;
- Validité: 12 mois.

El Pega y Sella Pecol Premium es una masilla monocomponente a base de poliuretano que cura en contacto con la humedad del aire, para sellados y pegados elásticos. Adequado para aplicaciones en el exterior e interior.

### Características

- Pega y Sella Premium tiene muy buena adherencia en la mayor parte de los materiales usados en la construcción, tiene excelente resistencia mecánica, buena consistencia y tixotropia;
- No escurre;
- Puede ser pintado después de curado. Aún así, recomendamos la realización de pruebas previas si utiliza pintura con base de aceites o revestimientos con gran carga de solventes;
- Inodoro después de curado;
- Producto no corrosivo;
- Buena resistencia a la intemperie;
- Buena resistencia al agua, ácidos débiles, alcalinos débiles, aguas residuales, aceites minerales, aceites vegetales, grasas, combustibles;
- Resistente a temperaturas entre los -40°C y los +90°C;
- Caducidad: 12 meses



CÓDIGO CODE / CODE / CÓDIGO	COR** COLOR / COULEUR / COLOR	CAPACIDADE CAPACITY / CAPACITÉ / CAPACIDAD	EMBALAGEM QUANTITY / EMBALLAGE / EMBALAJE	QTD. Palete PALET / QT. PALLETTE / CANT. PALÉ	
00300010000	Branco / white / Blanc / Blanco	9003	310 ml	12	900
00300020000	Cinza / grey / Gris / Gris	9037	310 ml	12	900
00300040000	Preto / black / Noir / Negro	9011	310 ml	12	900
FOIL 00300010001	Branco / white / Blanc / Blanco	9003	600 ml	18	720

\*\* Cor do produto aproximada à cor RAL / The color of the product is close to color RAL / Couleur du produit similaire à couleur RAL / Color del producto aproximada al color RAL



# Cola e Veda Special

Cola & Veda Special / Mastic de PU Special / Pega y Sella Special

O Cola e Veda Special é um produto mono componente de alto módulo à base de poliuretano, para utilizações num vasto leque de aplicações de vedação e colagem.  
O produto cura em contacto com a humidade do ar.

#### Características

- Cola e Veda Special tem muito boa aderência à maior parte dos substratos usados na construção, tem excelente resistência mecânica, boa consistência e tixotropia;
- Não escorre;
- Pode ser pintado depois de seco. Recomendamos todavia a realização de testes preliminares se utilizar tinta com base em óleos ou revestimentos com grande carga de solventes;
- Inodoro depois de seco;
- Produto não corrosivo;
- Boa resistência às intempéries;
- Boa resistência à água, ácidos fracos, álcalis fracos, esgotos, óleos minerais, óleos vegetais, gorduras, combustíveis;
- Resistente a temperaturas entre os -40°C e os +90°C;
- Validade: 12 meses.



Dados técnicos e ficha de segurança disponível sob pedido.

/ Technical information and safety data sheet available under request / Données techniques et fiche de sécurité disponible sur demande / Datos técnicos y ficha de seguridad disponible bajo pedido

dep.technico@pecol.pt

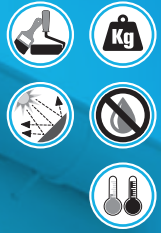

Cola & Veda Pecol Special is a one component polyurethane elastic adhesive, for interior applications in a wide range of sealing and bonding applications. It cures under the action of atmospheric moisture.

#### Characteristics

- The Cola & Veda Special exhibits excellent adhesion on all cement based materials, brick, ceramics, metals, wood, epoxy, polyester and acrylic resin;
- Can be painted over after full cure. Coatings containing solvents such as enamels, oils based or other components may cause the surface of the sealant to react creating a tacky surface. Preliminary tests recommended;
- Non corrosive;
- Good weathering and water resistance;
- Good resistance to water, weak acids, weak alkalis, sewerage, mineral oils, vegetable oils, fats, fuels;
- Temperature resistance from -40°C to +90°C;
- Shelf Life: 12 months.

Le Mastic de PU Special est un produit mono-composant à base de polyuréthane, pour utilisation sur un vaste nombre d'application de scellement et collage.

Le produit durcit au contact de l'humidité de l'air.

#### Caractéristiques

- Le Mastic de PU Special a une très bonne adhésion sur la plupart des support utilisés dans la construction, une excellente résistance mécanique, une bonne consistance et tixotropie;
- Ne coule pas;
- Peut être peint après séchage. Néanmoins, des tests préliminaires sont recommandés dans le cas d'utilisation de peinture à base d'huiles ou revêtement avec une grande charge de solvants;
- Inodore après séchage;
- Produit non corrosif;
- Bonne résistance aux intempéries;
- Bonne résistance à l'eau, acides faibles, alcalins faibles, égouts, huiles minérales, huiles végétales, graisses, combustibles;
- Résistant à des températures comprises entre -40°C et +90°C;
- Validité: 12 mois.

El Pega y Sella Special es un producto monocomponente a base de poliuretano, para utilizaciones en un amplio abanico de aplicaciones en sellado y pegado.

El producto cura en contacto con la humedad del aire.

#### Características

- Pega y Sella Special tiene muy buena adherencia a la mayoría de los sustratos usados en la construcción, tiene excelente resistencia mecánica, buena consistencia y tixotropia;
- No escurre;
- Puede ser pintado después de curado. Recomendamos sin embargo la realización de pruebas preliminares si utiliza pintura con base en aceites o revestimientos con gran carga de solventes;
- Inodoro después de curado;
- Producto no corrosivo;
- Buena resistencia a la intemperie;
- Buena resistencia al agua, ácidos fracos, álcalis fracos, alcantarillas, aceites minerales, aceites vegetales, grasas, combustibles;
- Resistente a temperaturas entre los -40°C y los +90°C;
- Caducidad: 12 meses

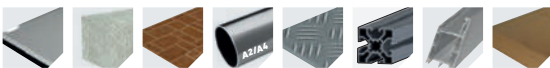

CÓDIGO CODE / CODE / CÓDIGO	COR** COLOR / COULEUR / COLOR	CAPACIDADE CAPACITY / CAPACITÉ / CAPACIDAD	EMBALAGEM QUANTITY / EMBALLAGE / EMBALAJE	QTD. Paleta PALET / QT. PALETTE / CANT. PALÉ	
003000500025	Branco / white / Blanc / Blanco	9003	300 ml	12	900
003000500026	Cinza / grey / Gris / Gris	9037	300 ml	12	900
003000500027	Branco / white / Blanc / Blanco	9003	600 ml	12	720 FOIL

\*\* Cor do produto aproximada à cor RAL / The color of the product is close to color RAL / Couleur du produit similaire à couleur RAL / Color del producto aproximada al color RAL





# VEDAÇÃO E COLAGEM

Sealing and Bonding / Étanche et Collage / Sellado y Pegado

## Cola e Veda Neutro Premium

Cola e Veda Neutral Premium / Mastic de PU Neutre Premium / Pega y Sella Neutra Premium



O Cola e Veda Neutro Premium é um mastique mono componente, pronto a aplicar, livre de solventes e isocianatos, com excelentes propriedades adesivas. Com elasticidade permanente, é o produto perfeito para colagens e vedações na maioria dos materiais utilizados na construção e na indústria. Tem uma grande resistência à intempérie e raios U.V. e pode ser aplicado tanto em interiores como em exteriores. O Cola e Veda Neutro Premium tem uma cor estável, não se alterando com o tempo, é pintável em diversos tipos de revestimento, amigo do ambiente e livre de produtos perigosos e prejudiciais à saúde.

### Características

- Para vedações e colagens;
- Excelente adesão na maioria dos materiais, mesmo que húmidos;
- Livre de solventes e isocianatos;
- Elasticidade permanente;
- Não corrosivo com metais;
- Aplicável tanto em interiores como em exteriores;
- Resistente à intempérie e aos raios U.V.;
- Adequado para pedra natural;
- Ação fungicida;
- Resistente a temperaturas entre os -40°C e os +80°C;
- Inodoro;
- Validade: 12 meses.

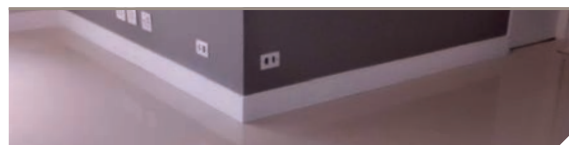

Dados técnicos e ficha de segurança disponível sob pedido.

/ Technical information and safety data sheet available under request / Données techniques et fiche de sécurité disponible sur demande / Datos técnicos y ficha de seguridad disponible bajo pedido dep.tecnico@pecol.pt

Cola e Veda Neutral Premium is a ready to use one component sealant, free of solvents and isocyanate, with a high adhesive properties and permanent elasticity. This is a perfect product for bonding and sealing of most materials used in the construction and industry. Very high U.V. and weathering resistance, can be used indoors and outdoors. Color stable, paintable at many coating systems, environmental safe and free of harmful components.

### Characteristics

- For sealing and bonding;
- Very good adhesion on most materials even on damp surfaces;
- Free of solvents and isocyanate;
- Permanent elasticity;
- Does not corrode metals;
- Can be applied indoors and outdoors;
- High weathering and U.V. resistance;
- Suitable for natural stone;
- Fungal resistant;
- Temperature resistance from -40°C to +80°C;
- Odorless;
- Shelf Life: 12 months.

Le Mastic de PU Neutre Premium est un produit mono-composant, prêt à appliquer, sans solvants et isocyanates, avec d'excellentes propriétés adhésives. Avec une élasticité permanente, ce produit est parfait pour collages et scellement de la plupart des matériaux utilisés dans la construction et l'industrie. Il est de grande résistance aux intempéries et aux rayons U.V. et peut être appliqué aussi bien en intérieurs qu'en extérieurs. Le Mastic de PU Neutre Premium a une couleur stable qui ne s'altère pas dans le temps, peut être peint sur plusieurs type de revêtement, ami de l'environnement et libre de produits dangereux et nocifs pour la santé.

### Caractéristiques

- Pour scellement et collage;
- Excellente adhésion sur la plupart des matériaux, même humide;
- Libre de solvants e isocyanates;
- Élasticité permanente;
- Non corrosif pour les métaux;
- Applicable aussi bien en intérieurs comme en extérieurs;
- Résistante aux intempéries et aux rayons U.V.;
- Adéquat pour pierre naturelle;
- Action fongicide;
- Résistant à des températures entre -40°C et +80°C;
- Inodore;
- Validité: 12 mois.

El Pega y Sella Neutra Premium es una masilla mono componente, lista para su aplicación, libre de disolventes e isocianatos, con excelentes propiedades adhesivas. Con elasticidad permanente, es el producto perfecto para pegados y sellados en la mayoría de los materiales utilizados en la construcción y en la industria. Cuenta con una alta resistencia a la intemperie y a los rayos UV y puede ser aplicada tanto en interiores como en exteriores. Este producto tiene un color estable, el cual no sufre alteraciones por el paso del tiempo. Se puede pintar en diversos tipos de revestimiento, respeta el medio ambiente y está libre de productos peligrosos y perjudiciales para la salud.

### Características

- Para sellados y pegados;
- Excelente adhesión en la mayoría de los materiales, también estando húmedos;
- Libre de disolventes e isocianatos;
- Elasticidad permanente;
- No corrosivo con los metales;
- Aplicable tanto en exterior como en interior;
- Resistente a la intemperie y a la acción de los Rayos U.V.;
- Adequado para piedra natural;
- Acción fungicida;
- Resistente a temperaturas entre -40 y +80°C;
- Inodoro;
- Caducidad: 12 meses



Disponível em

/ Available in / disponible en / Disponible



	CÓDIGO CODE / CODE / CÓDIGO	COR** COLOR / COULEUR / COLOR	CAPACIDADE CAPACITY / CAPACITÉ / CAPACIDAD	EMBALAGEM QUANTITY / EMBALLAGE / EMBALAJE	QTD. Palette PALET / QT. PALETTE / CANT. PALÉ
	003000022001	Branco / white / Blanc / Blanco	9003	290 ml	1248
	003000022004	Cinza / grey / Gris / Gris	9037	290 ml	1248
FOIL	003000022003	Branco / white / Blanc / Blanco	9003	300 ml	1440
FOIL	003000022002	Branco / white / Blanc / Blanco	9003	600 ml	720

\*\* Cor do produto aproximada à cor RAL / The color of the product is close to color RAL / Couleur du produit similaire a couleur RAL / Color del producto aproximada al color RAL

# POWER TACK

**SECAGEM RÁPIDA**  
FAST DRYING / DURCI RAPIDEMENT / SECADO RÁPIDO

**AGARRE IMEDIATO**  
STRONG INITIAL GRAB / MAINTIEN IMMÉDIATEMENT / AGARRE IMEDIATO



ULTRA RÁPIDO



AGARRE INICIAL



SEM PREGOS

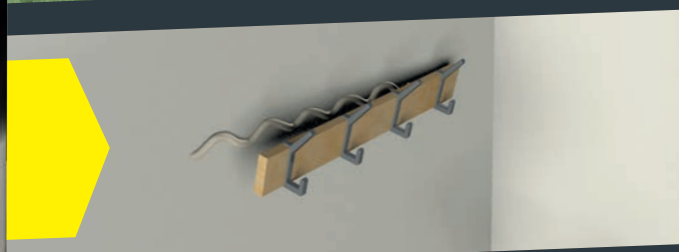
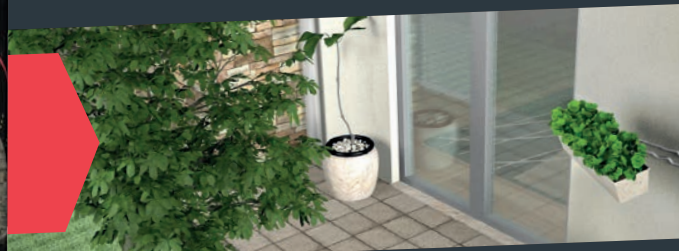

✓ **FORTE AGARRE INICIAL 250 Kg/m<sup>2</sup>**

Strong initial grab 250kg/m<sup>2</sup> / Forte prise initiale 250kg/m<sup>2</sup>  
/ Fuerte agarre inicial 250kg/m<sup>2</sup>

✓ **COLAGEM RÁPIDA E RESISTENTE**

Fast and sturdy collage / Collage rapide et robuste / Pega de forma rápida y resistente

✓ **COLA E VEDA TODO O TIPO DE SUBSTRATOS\***

Cola and seals all kinds of substrates\* / Adhésion et étanchéité sur tout les matériaux\* / Pega y sella todo tipo de materiales\*

✓ **NÃO CORRÓI METAIS**

Do not corrode metals / Ne rouille pas les métaux / No corroe metales

✓ **PODE SER APLICADO EM SUPERFÍCIES HÚMIDAS**

Can be applied to damp surfaces / Peut être appliqué sur des surfaces humides  
/ Puede ser aplicado en superficies húmedas

✓ **PRODUTO ECOLÓGICO, ISENTO DE SOLVENTES, SILICONES E ISOCIANATOS**

Ecological product, free solvents, silicones and isocyanates  
/ Produit écologique, sans solvants, isocyanates et silicones  
/ Producto ecológico, exento de solventes, siliconas e isocianatos

✓ **RESISTENTE AOS RAIOS U.V.**

Resistant to U.V. / Résistant aux rayons U.V. / Resistente a los rayos U.V.

**FIXAÇÃO**

# EXTRA FORTE

EXTRA STRONG GRAB / FIXATION EXTRA FORT / FIJACIÓN EXTRA FUERTE



# VEDAÇÃO E COLAGEM

Sealing and Bonding / Étanche et Collage / Sellado y Pegado

## Power Tack

Power Tack / Power Tack / Power Tack



Power Tack é uma cola de montagem universal extremamente poderosa e permanentemente flexível. Possui um agarre inicial extremamente forte (250 kg/m<sup>2</sup>).

Power Tack é uma cola de montagem universal de alta qualidade, monocomponente com base polímero híbrido STP, especialmente desenvolvido para colagem de elementos sem recurso a grampos de fixação. Possui um agarre inicial extremamente forte e uma elevada aderência, particularmente adequado para substratos porosos e aplicações verticais. Cura em reação com a humidade atmosférica e forma uma junta permanentemente flexível. Não contém solventes, ácidos, ou isocianatos.

Pode ser aplicado em superfícies húmidas.

### Características

- Cola todo o tipo de materiais, leves ou pesados. Utilizado na Indústria da construção, engenharia, setor automóvel e na construção naval;
- Montagem de rodapés, janelas, soleiras, materiais de isolamento, placas de gesso, guarnições, ...;
- Grande poder de aderência em vidros, betão, materiais sintéticos, pedra natural, madeira, aço inoxidável, telhas, e na maioria dos substratos utilizados na construção;
- Fácil de aplicar e manusear, com boa capacidade de enchimento;
- Pintável (exceto com tintas de resina alquídica);
- Inodoro. Isento de solventes e não é corrosivo;
- Resistente à intempérie e aos raios U.V.;
- Validade: 12 meses.



Dados técnicos e ficha de segurança disponível sob pedido.

Technical information and safety data sheet available under request / Données techniques et fiche de sécurité disponible sur demande / Datos técnicos y ficha de seguridad disponible bajo pedido dep.tecnico@pecol.pt

Power Tack is a universal mounting glue extremely powerful and permanently flexible. It has an extremely strong initial grab (250 kg/m<sup>2</sup>). Power Tack is a universal mounting glue high quality, mono-component base polymer hybrid STP. It has an extremely strong initial grab and high adhesion, forming a permanent, durable elastic rubber. Particularly suitable for porous substrates and vertical applications. In most of the applications clapping is not required. It is free of solvent, acids and isocyanates. It can be applied to damp surfaces.

### Characteristics

- Bond all kinds of materials, light or heavy used in the building industry, engineering, automotive industry and shipbuilding;
- Installation of baseboards, windows, sills, insulation materials, plasterboard, trimmings,
- powerful adhesion on glass, concrete, synthetic materials, natural stone, wood, stainless steel, tiles, and most substrates used in construction;
- Easy to apply and handle, with good filling capacity;
- Paintable (except alkyd resin paints);
- Odorless. Solvent-free and non-corrosive;
- Resistant to weathering and UV;
- Shelf Life: 12 months.

Power Tack est une colle de montage universel extrêmement puissant et flexible. Super High Tack dispose d'une prise initiale extrêmement fort (250 kg/m<sup>2</sup>).

Power Tack est une colle de montage universel de haute qualité, mono-composant à base de polymère hybride STP, spécialement développé pour le collage d'éléments sans avoir besoin de pinces de fixation. Il dispose d'une excellente prise initiale et une adhérence élevée, adéquat aux substrats poreux et application vertical. Polymérisation même en contact avec l'humidité atmosphérique et forme un joint flexible de façon permanente. Sans solvants, acides ou des isocyanates. Peut être appliqué sur des surfaces humides.

### Caractéristiques

- Colle toutes sortes de matériaux, légers ou lourds. Utilisé dans l'industrie de la construction, l'ingénierie, construction navale et industrie automobile.
- Utilisé pour la pose des plinthes, des fenêtres, seuils, matériaux d'isolation, plaques de plâtre, accessoires des portes et fenêtres ...;
- Excellente adhérence sur le verre, béton, matériaux synthétiques, pierre naturelle, bois, acier inoxydable, tuile, et la plupart des substrats utilisés dans la construction;
- Simple à appliquer et à opérer, avec une bonne capacité de remplissage;
- Peut être peint (sauf les peintures de résine alkyde);
- Inodore. Sans solvant et non corrosif;
- résistant aux intempéries et aux rayons U.V.
- Validité: 12 mois.

Power Tack es un potente pegamento de montaje universal y flexible permanentemente. Tiene un agarre muy fuerte (250 kg/m<sup>2</sup>).

Power Tack es un pegamento monocomponente a base de polímero híbrido STP especialmente desarrollado para la unión de elementos sin el uso de abrazaderas. Tiene un agarre inicial extremadamente fuerte y elevada adherencia, especialmente adecuado para materiales porosos y aplicaciones verticales. Cura al reaccionar con la humedad atmosférica y forma una junta permanentemente flexible. No contiene disolventes ni ácidos o isocianatos. Se puede aplicar a superficies húmedas.

### Características

- Pegue todo tipo de materiales, ligero o pesado. Se utiliza en la industria de la construcción, ingeniería, sector automotriz y en la construcción naval .
- Para instalación de rodapiés, ventanas, marcos, materiales aislantes, placas de yeso, adornos, ...;
- Gran poder de adherencia sobre vidrio, hormigón, materiales sintéticos, piedra natural, madera, acero, acero inoxidable, azulejos, y en la mayoría de los materiales utilizados en la construcción;
- Fácil de aplicar y manipular, con buena capacidad de llenado;
- Se puede pintar (a excepción de pinturas de resina alquídica);
- Inodoro. Sin disolventes y resistente a la corrosión;
- Resistente a la intemperie y a los rayos UV;
- Caducidad: 12 meses.



CÓDIGO CODE / CODE / CÓDIGO	COR** COLOR / COULEUR / COLOR	CAPACIDADE CAPACITY / CAPACITÉ / CAPACIDAD	EMBALAGEM QUANTITY / EMBALLAGE / EMBALLAJE	QTD. Paletes PALET / QT. PALETTE / CANT. PALÉ	
002602000000	Branco / white / Blanc / Blanco	9003	300 ml	12	900

\*\* Cor do produto aproximada à cor RAL / The color of the product is close to color RAL / Couleur du produit similaire a couleur RAL / Color del producto aproximada al color RAL





# MSP 70 Premium

MSP 70 Premium / MSP 70 Premium / MSP 70 Premium

O MSP 70 Premium é um selante monocomponente, pronto a aplicar e com base em polímeros silano terminados. É um selante com grande poder adesivo e com uma dureza shore A elevada. O MSP 70 Premium apresenta excelentes níveis de performance, juntamente com um excelente poder de colagem em quase todo o tipo de superfícies – porosas e não porosas – na indústria metálica e na construção. Apresenta uma cor estável, não se alterando ao longo do tempo, resistente à intempérie e pintável com quase todo o tipo de revestimentos. É ainda amigo do ambiente e não contém nenhum tipo de componente perigoso e prejudicial à saúde.

### Características

- Excelente adesão em superfícies porosas e não porosas, mesmo que húmidas;
- Boas propriedades mecânicas com elevados níveis de resistência à tração após a cura;
- Vantagens ecológicas: não contém isocianatos, silicões e solventes;
- Cor estável e resistência aos raios U.V.;
- Pintável, mesmo quando fresco, com a maioria das tintas;
- Odor agradável;
- Não corrosivo com metais;
- Adequado para pedra natural;
- Aplicável em interiores e exteriores;



**i** Dados técnicos e ficha de segurança disponível sob pedido.  
/ Technical information and safety data sheet available under request / Données techniques et fiche de sécurité disponible sur demande / Datos técnicos y ficha de seguridad disponible bajo pedido  
dep.tecnico@pecol.pt



MSP 70 Premium is a ready to use, one component sealant, based on silane-terminated polymers. It is a high quality adhesive-sealant with high stiffness and very high adhesive strength. The product exhibits high performance mechanical properties along with outstanding bond strength and sealing on nearly all surfaces – porous and non porous – in the construction and metal industry. Color stable, weather resistant, paintable at many coating systems, environmental safe and free of harmful components including isocyanates.

### Characteristics

- Outstanding adhesion on porous and non porous substrates even on damp surfaces;
- High performance mechanical properties with high shear strength after full cure;
- Ecological advantages: does not contain isocyanate, silicone or solvent.;
- Color stability and U.V. resistance;
- Can be painted wet-on-wet in paint trains with most industrial paints;
- Friendly odour;
- Does not corrode metals;
- Suitable for natural stone;
- Can be applied indoors and outdoors.

Le MSP 70 Premium est un mastic mono-composant, prêt à appliquer et avec une base de polymères de silane terminés. C'est un mastic avec un grand pouvoir d'adhésion et une dureté Shore A élevée. Le MSP 70 Premium présente d'excellents niveaux de performance, avec un excellent pouvoir de collage sur presque tous les types de surfaces – poreuses et non-poreuses – dans l'industrie mécanique et dans la construction. Il présente une couleur stable, qui ne s'altère pas au long du temps, résiste aux intempéries et peut être peint sur pratiquement tous les revêtements. Il est ami de l'environnement et ne contient aucuns types de composant dangereux et nocifs pour la santé.

### Caractéristiques

- Excellente adhésion sur supports poreux et non-poreux, même humides;
- Bonnes propriétés mécaniques avec de hauts niveaux de résistance à la traction après durcir;
- Avantages écologiques: ne contient pas d'isocyanates, silicões et solvants;
- Couleur stable et résistance aux rayons U.V.;
- Peut être peint, même frais avec la plupart des peintures;
- Odeur agréable;
- Non corrosif pour les métaux;
- Adéquat pour pierre naturelle;
- Applicable en intérieurs et extérieurs;

El MSP 70 Premium es un sellante monocomponente, listo para aplicar y con base en polímeros silano terminados. Es un sellante con gran poder adhesivo y con una dureza shore A elevada. El MSP 70 Premium presenta excelentes niveles de prestaciones, juntamente con un excelente poder de pegado en casi todo tipo de superficies – porosas y no porosas – en la industria metálica y en la construcción. Presenta un color estable, no se altera a lo largo del tiempo, resistente a la intemperie y pintable en casi todo tipo de revestimientos. Es también amigo del ambiente y no contiene ningún tipo de componente peligroso y perjudicial a la salud.

### Características

- Excelente adhesión en superficies porosas y no porosas, aunque húmedas;
- Buenas propiedades mecánicas con elevados niveles de resistencia a la tracción tras la cura;
- Ventajas ecológicas: no contiene isocianatos, silicões y solventes;
- Color estable y resistencia a los rayos U.V.;
- Pintable, incluso fresco, con la mayoría de las pinturas;
- Olor agradable;
- No corrosivo con metales;
- Adequado para piedra natural;
- Aplicable en interiores y exteriores;
- Puede ser pintable.



CÓDIGO CODE / CODE / CÓDIGO	COR** COLOR / COULEUR / COLOR	CAPACIDADE CAPACITY / CAPACITÉ / CAPACIDAD	EMBALAGEM QUANTITY / EMBALLAGE / EMBALAJE	QTD. PALETTE PALET / QT. PALETTE / CANT. PALÉ		
003000500008	Branco / White / Blanc / Blanco	9003	300 ml	12	900	
003000500010	Preto / Black / Noir / Negro		300 ml	12	900	
003000501002	Branco / White / Blanc / Blanco	9003	300 ml	30	1440	FOIL
003000501001	Branco / White / Blanc / Blanco	9003	600 ml	18	720	FOIL

\*\* Cor do produto aproximada à cor RAL / The color of the product is close to color RAL / Couleur du produit similaire à couleur RAL / Color del producto aproximada al color RAL



Disponível em  
/ Available in / disponible en  
/ Disponible





# VEDAÇÃO E COLAGEM

Sealing and Bonding / Étanche et Collage / Sellado y Pegado

## MSP 50 Premium

MSP 50 Premium / MSP 50 Premium / MSP 50 Premium



O MSP 50 Premium é um selante mono componente, com base em polímeros de silano modificados. É um adesivo/selante de grande qualidade, com alta elasticidade, perfeito para colagens e vedações da maior parte de substratos e superfícies (porosas e não porosas). Aconselhado para o setor da construção, engenharia, setor automóvel, construção naval, interiores e exteriores.

O MSP 50 Premium combina um forte poder de colagem com uma elasticidade adequada.

Cor estável, não se altera com o tempo, Resistente à intempérie, pintável em diversos tipos de revestimento, amigo do ambiente e livre de produtos perigosos e prejudiciais, incluindo isocianatos.

### Características

O MSP 50 Premium tem um elevado poder de aderência numa variada gama de substratos porosos e não porosos, tais como: PVC; Madeira tratada; Betão; Pedra Natural; Vidro, vidro de segurança, vidro laminado; Alumínio, aço, aço inox, zinco, ...; Aplicável em superfícies húmidas;

O MSP 50 Premium tem uma dureza Shore relativamente alta, portanto o seu uso é adequado como uma cola elástica de longa duração e em aplicações como selante na construção, indústria metálica, indústria automóvel e obras de engenharia;

Cor estável e resistente aos raios U.V.;

Pintável, mesmo quando fresco, com a maioria das tintas;

Inodoro;

Não corrosivo com metais;

Validade: 12 meses.



Dados técnicos e ficha de segurança disponível sob pedido.

/ Technical information and safety data sheet available under request / Données techniques et fiche de sécurité disponible sur demande / Datos técnicos y ficha de seguridad disponible bajo pedido

dep.tecnico@pecol.pt

MSP 50 Premium is a ready to use, one component sealant, based on silane-terminated polymers. It is a high quality adhesive sealant with permanent elasticity, perfect for bonding and sealing of most materials on nearly all surfaces - porous or non porous - in the building sector, engineering, automotive, shipbuilding, for indoor and outdoor.

The MSP 50 Premium combines a strong adhesive power with a very good elasticity. Color stable, weather resistant, paintable at many coating systems, environmental safe and free of harmful components including isocyanates.

### Characteristics

The MSP 50 Premium exhibits excellent adhesion in an entire serie of porous and non-porous substrates, specifically:

PVC; Treated wood; Stone and concrete; Natural stone; Glass, safety glass, laminated glass; Aluminium, steel, stainless steel, Zinc, lead, inox, ...; HPL-plates (Trespa, ki-core...).

The MSP50 Premium is a relative high shore A hardness and is therefore especially designed as elastic glue for long lasting bonding and sealing applications in construction, metal industry, automotive and plant engineering industries;

Color stability and U.V. resistance;

Can be painted wet-on-wet in paint trains with most industrial paints;

Odorless;

Does not corrode metals;

Shelf Life: 12 months.

MSP 50 Premium est un mastic mono-composant à base de polymères de silane modifiés. C'est un adhésif de grand qualité, haute l'élasticité, parfait pour le collage et le scellage de la plupart des supports et des surfaces (poreuses ou non poreuses). Il est conseillé pour le secteur de la construction, l'ingénierie, le secteur automobile, la construction navale, les intérieurs et les extérieurs.

Le MSP 50 Premium combine une très forte adhésion avec une élasticité adéquate. De couleur stable, il ne change pas avec le temps, résistant aux intempéries, il peut être peint sur divers types de revêtements, amis de l'environnement et libre de composants nocifs, il ne contient pas d'isocyanates.

### Caractéristiques

Le MSP 50 Premium a une très bonne d'adhésion sur plusieurs supports poreux et non-poreux, tels que:

PVC; Bois traité; Bitume; Roche Naturel; Verre, verre de sécurité, verre laminé; Aluminium, acier, acier inox, zinc, ...

MSP 50 Premium a une dureté shore relativement élevée, donc son utilisation est appropriée comme colle élastique de longue durée et comme étancheur dans la construction, l'industrie métallique, l'industrie automobile et d'autres œuvres d'ingénierie;

Sans solvants, isocyanates et silicone;

Couleur stable et résistant aux rayons U.V.;

Peut être peint;

Inodore

Non corrosifs pour métaux;

Validité: 12 mois.

O MSP 50 Premium é um selante mono componente, com base em polímeros de silano modificados. É um adesivo/selante de grande qualidade, com alta elasticidade, perfeito para colagens e vedações da maior parte de substratos e superfícies (porosas e não porosas). Aconselhado para o setor da construção, engenharia, setor automóvel, construção naval, interiores e exteriores.

O MSP 50 Premium combina um forte poder de colagem com uma elasticidade adequada.

Cor estável, não se altera com o tempo, Resistente à intempérie, pintável em diversos tipos de revestimento, amigo do ambiente e livre de produtos perigosos e prejudiciais, incluindo isocianatos.

### Características

El MSP 50 Premium tiene un elevado poder de adherencia en una variada gama de materiales porosos y no porosos, tales como:

PVC; Madera tratada; Hormigón; Piedra Natural; Vidrio, vidrio de seguridad, vidrio laminado; Aluminio, acero, acero inox, zinc, ...;

El MSP 50 Premium tiene una dureza shore relativamente alta, por tanto su uso es adecuado como un pegamento elástico de larga duración y en aplicaciones como sellante en la construcción, industria metálica, industria automóvil y obras de ingeniería;

Inodoro;

Puede ser pintable;

Color estable y resistente a los rayos U.V.

Caducidad: 12 meses.



Disponível em

/ Available in / disponible en / Disponible



CÓDIGO CODE / CODE / CÓDIGO	COR** COLOR / COULEUR / COLOR	CAPACIDADE CAPACITY / CAPACITÉ / CAPACIDAD	EMBALAGEM QUANTITY / EMBALLAGE / EMBALAJE	QTD. PALETE PALET / QT. PALETTE / CANT. PALÉ	
003000500022	Branco / White / Blanc / Blanco	9003	290 ml	12	900
003000500023	Preto / Black / Noir / Negro	9011	290 ml	12	900
003000500021	Cinza / Grey / Gris / Gris	7037	290 ml	12	900
003000500024	Telha / Tile / Tuile / Teja	2012	290 ml	12	900
FOIL 003000500028	Branco / White / Blanc / Blanco	9003	300 ml	30	1440
FOIL 003000500029	Branco / White / Blanc / Blanco	9003	600 ml	18	720

\*\* Cor do produto aproximada à cor RAL / The color of the product is close to color RAL / Couleur du produit similaire a couleur RAL / Color del producto aproximada al color RAL



# MSP 30 Premium

MSP 30 Premium / MSP 30 Premium / MSP 30 Premium

Selante monocomponente pronto a usar à base de polímeros terminados em silano. MSP 30 é usado para selar e efectuar colagens diversas na indústria da construção. Excelente aderência em quase todos os substratos, incluindo superfícies porosas e não porosas. Cor estável e resistência às intempéries são das principais vantagens do produto. É ainda pintável em muitos sistemas de revestimento, resistente a fungos, amigo do ambiente e livre de componentes prejudiciais, incluindo isocianatos.

#### Características

- Cura em contacto com a atmosfera;
- Excelente adesão em substratos porosos e não porosos;
- Resistente aos raios UV;
- Boa resistência térmica (-40° a + 80°);
- Permanece elástico depois de curado;
- Adere em superfícies húmidas;
- Boa resistência a substâncias químicas;
- Pintável e envernizável depois de seco;
- Produto ecológico, livre de isocianatos, solventes e ácidos;
- Inodoro;
- Validade: 12 meses.

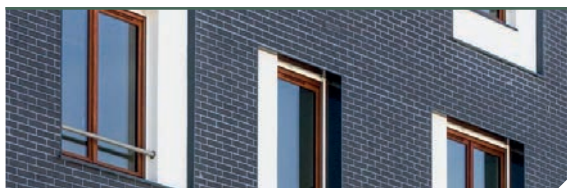

**i** Dados técnicos e ficha de segurança disponível sob pedido.  
/ Technical information and safety data sheet available under request / Données techniques et fiche de sécurité disponible sur demande / Datos técnicos y ficha de seguridad disponible bajo pedido  
dep.tecnico@pecol.pt

Single-component sealant ready for use based on silane-terminated polymers. MSP 30 is used to seal and perform several collages in the construction industry. Excellent adherence to almost all substrates including porous and non-porous surfaces. Stable colour and weather resistance are the main advantages of the product. It is also paintable in many coating systems, resistant to fungi, environmentally friendly and free of harmful components, including isocyanates.

#### Characteristics

- Curing in contact with the atmosphere;
- Excellent adherence on porous and non-porous substrates;
- UV-Ray Resistant;
- Good Thermal Resistance (-40° to + 80°);
- Remains elastic after curing;
- Adheres to damp surfaces;
- Good resistance to chemicals;
- Paintable and possible to varnish after dry;
- Ecological product, free of isocyanates, solvents and acids;
- Odourless;
- Shelf Life: 12 months.

Le MSP 30 est un mastic mono-composant prêt à appliquer et avec une base de polymères de silane terminés. Le MSP 30 est utilisé pour étancher et effectuer divers collages dans la construction. Excellente adhérence à la plupart des substrats, y compris les surfaces poreuses et non poreuses. Les principales avantages du produit sont la couleur stable qui ne s'altère pas au long du temps et résiste aux intempéries. Il peut être peint dans la plupart des revêtements, résiste aux moisissures, respecte de l'environnement et n'a pas de composants dangereux pour la santé, y compris les isocyanates.

#### Caractéristiques

- Durci en contact avec l'atmosphère;
- Excellente adhérence sur des substrats poreux et non poreux;
- Résistant aux rayons UV;
- Bonne résistance thermique (-40 ° à + 80);
- Reste élastique après durcissement;
- Adhère aux surfaces humides;
- Bonne résistance aux produits chimiques;
- Compatible avec la peinture et vernis une fois sec;
- Produit écologique, sans isocyanates, solvants ni acides;
- Inodore;
- validité: 12 mois.

Selador monocomponente listo para usar a base de polímeros en base de silano. MSP 30 se usa para sellar y realizar diversas uniones en la industria construcción. Excelente adherencia en casi todos los materiales, incluyendo superficies porosas y no porosas. Su color estable y la resistencia a la intemperie son las principales ventajas del producto. También se puede pintar en muchos sistemas de revestimiento, resistente a los hongos, respetuoso con el medio ambiente y libre de componentes dañinos, incluyendo isocianatos.

#### Características

- Curado en contacto con la atmósfera;
- Excelente adherencia sobre materiales porosos y no porosos;
- Resistente a los rayos UV;
- Buena resistencia térmica (-40°C a +80°C);
- Permanece elástico después de curar;
- Se adhiere a superficies húmedas;
- Buena resistencia a los productos químicos;
- Se puede pintar y barnizar cuando está seco;
- Producto ecológico, libre de isocianatos, solventes y ácidos;
- Inodoro;
- Caducidad: 12 meses.



CÓDIGO CODE / CODE / CÓDIGO	COR** COLOR / COULEUR / COLOR	CAPACIDADE CAPACITY / CAPACITÉ / CAPACIDAD	EMBALAGEM QUANTITY / EMBALLAGE / EMBALAJE	QTD. PALETE PALET / QT. PALETTE / CANT. PALÉ	
003000500020	Branco / White / Blanc / Blanco	9003	290 ml	12	900

\*\* Cor do produto aproximada à cor RAL / The color of the product is close to color RAL / Couleur du produit similaire à couleur RAL / Color del producto aproximada al color RAL





# VEDAÇÃO E COLAGEM

Sealing and Bonding / Étanche et Collage / Sellado y Pegado

## MSP Cristal Premium

MSP Cristal Premium / MSP Cristal Premium / MSP Cristal Premium

**CE**  
 14  
 PECOL  
 EN 15651-1: F-INT  
 DoP: 21-44-14-1  
 www.pecol.pt

Selante translúcido, O MSP Cristal Premium é um selante/adesivo de elevada qualidade, com base em polímeros de silano modificados, com a capacidade de selar, colar e vedar, tudo ao mesmo tempo. Adequado para praticamente todo o tipo de materiais de construção, sejam porosos ou não porosos. Com permanente elasticidade, permite uma adesão excelente sem o uso de primário. Tem igualmente excelentes resultados quando aplicado em superfícies húmidas.

Para uso exclusivo no interior.

### Características

- Transparente / cristalino;
- Fácil aplicação e manuseamento;
- Boa capacidade de preenchimento de juntas;
- Baixo módulo e boa movimentação da junta;
- Isento de solventes e isocianatos;
- Não corrosivo com metais;
- Flexível a baixas (-40°C) e altas (+80°C) temperaturas;
- Inodoro;
- Validade: 12 meses.



Dados técnicos e ficha de segurança disponível sob pedido.

/ Technical information and safety data sheet available under request / Données techniques et fiche de sécurité disponible sur demande / Datos técnicos y ficha de seguridad disponible bajo pedido  
 dep.tecnico@pecol.pt

Crystal clear, high quality adhesive sealant based on silane modified polymer technology for bonding, fixing and sealing at the same time. Suitable for practically all building materials even porous and non-porous. Permanent elasticity and excellent adhesion without the use of primer and even on a slightly damp surfaces.

### Characteristics

- Transparent / crystal clear;
- Easy to work and tool;
- Good gap filling capacity;
- Low modulus and high movement capability;
- Free of solvents and isocyanates;
- Does not corrode metals;
- Flexible at low (-40°C) and high (+80°C) temperatures;
- Odourless;
- Shelf Life: 12 months.

Mastic translucide, le MSP Cristal Premium est un mastic/adhésif de haute qualité, avec une base de polymères de silane modifiés, avec la capacité de sceller, coller et étancher toutes en même temps. Adéquat pour pratiquement tous les types de matériaux de construction, poreux ou non-poreux. Avec une élasticité permanente, il permet une excellente adhésion sans utilisation de primaire. Il a également d'excellent résultat dans des applications sur surfaces humides.

### Caractéristiques

- Transparent/cristallin;
- Facile application et maniement ;
- Bonne capacité de remplissage des jointes;
- Bas module et bon mouvement de la jointe;
- Sans solvants et isocyanates;
- Non corrosif pour les métaux;
- Flexible à basses (-40°C) et hautes (+80°C) températures;
- Inodoro;
- Validité: 12 mois.

Sellante translúcido, el MSP Cristal Premium es un sellante/adhesivo de elevada calidad, con base en polímeros de silano modificados, con la capacidad de sellar y pegar, todo al mismo tiempo. Adequado para prácticamente todo tipo de materiales de construcción, sean porosos o no porosos. Con permanente elasticidad, permite una adhesión excelente sin el uso de imprimación. Tiene igualmente excelentes resultados cuando es aplicado en superficies húmedas.

### Características

- Transparente / cristalino;
- Fácil aplicación y manipulación;
- Buena capacidad de relleno de juntas;
- Bajo módulo y buena movilización de la junta;
- Exento de solventes y isocianatos;
- No corrosivo con metales;
- Flexible a bajas (-40°C) y altas (+80°C) temperaturas;
- Inodoro;
- Caducidad: 12 meses.

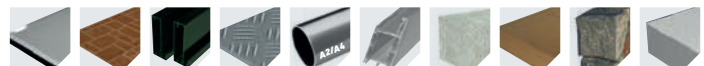

CÓDIGO CODE / CODE / CÓDIGO	COR** COLOR / COULEUR / COLOR	CAPACIDADE CAPACITY / CAPACITÉ / CAPACIDAD	EMBALAGEM QUANTITY / EMBALLAGE / EMBALAJE	QTD. PALETE PALET / QT. PALLETTE / CANT. PALÉ
003000500019	Cristal / Crytal / Cristal / Cristal	290 ml	12	900

**PECOL®**



**POWERCOAT**

**STOP**  
**ÀS INFILTRAÇÕES**

Stop to the infiltrations  
/ Arrêtez l'infiltration  
/ Stop a las infiltraciones

**FÁCIL DE APLICAR**  
APLICACIÓN FÁCIL



100%  
IMPERMEÁVEL  
IMPERMEABLE

**IMPERMEABILIZAÇÃO TOTAL**

Total waterproofing / Imperméabilisation totale / Impermeabilización total

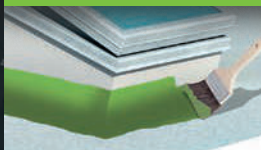

**CLARABÓIAS**  
Skylights  
/ Puits de lumière  
/ Claraboyas



**CALEIRAS**  
Gutters  
/ Gouttières  
/ Canalones

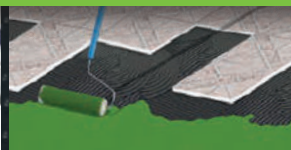

**TERRAÇOS**  
Terraces  
/ Terrasses  
/ Terrazas



**FACHADAS**  
Facades  
/ Façades  
/ Fachadas



**FLOREIRAS**  
Flower pots  
/ Pots de fleurs  
/ Jardinera



**PINTÁVEL**  
Paintable  
/ Peut être peint  
/ Puede ser pintado



**FLEXÍVEL**  
Flexible  
/ Flexible  
/ Flexible



**RESISTENTE À ÁGUA ESTAGNADA**  
Stagnant water resistant  
/ Résistant à l'eau stagnante  
/ Resistente al agua estancada



**RESISTENTE AOS RAIOS U.V.**  
Resistant to U.v. Rays  
/ Résistant aux Rayons U.V.  
/ Resistente los rayos U.V.

**DISPONÍVEL EM**

**BRANCO**  
White / Blanc / Blanco

**CINZA**  
Grey / Gris / Gris

**TERRACOTA**  
Terracotta / Terre Cuite / Terracota



**APLICÁVEL EM SUPERFÍCIES HÚMIDAS**  
Apply on wet surfaces  
/ Appliquer sur des surfaces humides  
/ Aplicable en húmedo



**INODORO**  
Odorless  
/ Inodore  
/ Inodoro



**VISITÁVEL**  
Visitable  
/ Visitable  
/ Visitable

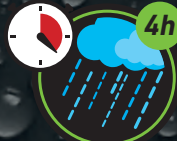

**RESISTENTE À CHUVA APOÓS 4H**  
Resistant to rain after 4h  
/ Résistant à la pluie après 4h  
/ Resistente a la lluvia después de 4h



# VEDAÇÃO E COLAGEM

Sealing and Bonding / Étanche et Collage / Sellado y Pegado

## Impermeabilizante Líquido Power Coat

Waterproofing Liquid Power Coat / Produit d'étanchéité liquide Power Coat / Impermeabilizante Líquido Power Coat



Impermeabilizante líquido de polímero MS monocomponente, que cura com a humidade atmosférica formando uma membrana contínua com elevada elasticidade, para impermeabilização e reparação de telhados, caleiras, fissuras, uniões. Não contém isocianatos nem solventes.

### Características

- Boa adesão à maioria dos substratos utilizados na construção: cimento, argamassa, telha...
- Forma uma membrana contínua e totalmente impermeável que resiste ao contacto permanente com a água;
- É permeável ao vapor de água;
- Fácil aplicação;
- Apresenta grande elasticidade;
- Capacidade de enchimento elevada;
- Apresenta grande resistência aos raios UV e intempérie;
- Pode aplicar-se sobre superfícies húmidas;
- Não contém isocianatos;
- Mantém as propriedades a temperaturas compreendidas entre -40°C e +90°C.
- Rentabilidade: 1,5-3,0Kg/m<sup>2</sup> (quando aplicada uma espessura de aproximadamente 1,4mm de produto).



Dados técnicos e ficha de segurança disponível sob pedido.

/ Technical information and safety data sheet available under request / Données techniques et fiche de sécurité disponible sur demande / Datos técnicos y ficha de seguridad disponible bajo pedido  
dep.technico@pecol.pt

MS polymer single-component waterproofing liquid, which cures with atmospheric humidity forming a continuous membrane with high elasticity, for waterproofing and repairing of roofs, gutters, cracks, joints. Contains no isocyanates or solvents.

### Characteristics

- Good adhesion to most substrates used in construction: cement, mortar, tile;
- It forms a continuous and totally watertight membrane that resists the permanent contact with the water;
- It is permeable to water vapour;
- Easy application;
- Has great elasticity;
- High filling capacity;
- It exhibits great resistance to UV rays and weathering;
- Can be applied on wet surfaces;
- Does not contain isocyanates;
- Maintains properties at temperatures between -40°C and +90°C;
- Profitability: 1.5-3.0 Kg/m<sup>2</sup> (when applied a thickness of approximately 1.4 mm of product).

Produit d'étanchéité liquide de polymère MS monocomposant, qui durcit avec l'humidité atmosphérique formant une membrane continue à haute élasticité, pour l'imperméabilisation et la réparation des toits, gouttières, fissures, joints. Ne contient pas d'isocyanates ou de solvants.

### Caractéristiques

- Bonne adhérence à la plupart des substrats utilisés dans la construction: ciment, mortier, tuile;
- Il forme une membrane continue et totalement imperméable qui résiste au contact permanent avec l'eau;
- Il est perméable à la vapeur d'eau;
- Application facile;
- Il présente une grande élasticité;
- Capacité de remplissage élevée;
- Il présente une grande résistance aux rayons UV et aux intempéries;
- Peut être appliqué sur des surfaces humides;
- Ne contient pas d'isocyanates;
- Maintient les propriétés à des températures comprises entre -40°C et +90°C;
- Rentabilité: 1,5-3,0kg/m<sup>2</sup> (en cas d'application d'une épaisseur d'environ 1,4 mm de produit).

Impermeabilizante líquido de polímero MS monocomponente, que cura com a humidade atmosférica formando uma membrana contínua com elevada elasticidade, para impermeabilização e reparação de telhados, caleiras, grietas, uniões. Não contém isocianatos nem solventes.

### Características

- Buena adhesión a la mayoría de los sustratos utilizados en la construcción: cemento, mortero, teja;
- Forma una membrana continua y totalmente impermeable que resiste al contacto permanente con el agua;
- Es permeable al vapor de agua;
- Fácil aplicación;
- Presenta gran elasticidad;
- Elevada capacidad de llenado;
- Presenta gran resistencia a los rayos UV e intemperie;
- Puede aplicarse sobre superficies húmedas;
- No contiene isocianatos;
- Mantiene las propiedades a temperaturas comprendidas entre -40°C y +90°C;
- Rentabilidad: 1,5-3,0 Kg/m<sup>2</sup> (cuando se aplica un espesor de aproximadamente 1,4 mm de producto).



CÓDIGO CODE / CODE / CÓDIGO	COR** COLOR / COULEUR / COLOR	CAPACIDADE CAPACITY / CAPACITÉ / CAPACIDAD	EMBALAGEM QUANTITY / EMBALLAGE / EMBALAJE
003300000043	Branco / white / Blanc / Blanco	1 kg	1
003300000037		5 kg	1
003300000040		15 kg	1
003200000035	Cinza / grey / Gris / Gris	1 kg	1
003300000038		5 kg	1
003300000041		15 kg	1
003200000036	Terracota / Terracotta / Terre Cuite / Terracota	1 kg	1
003300000039		5 kg	1
003300000042		15 kg	1

\*\* Cor do produto aproximada à cor RAL / The color of the product is close to color RAL / Couleur du produit similaire à couleur RAL / Color del producto aproximada al color RAL



### CLARABÓIAS

Skylights / Puits de lumière / Claraboyas



### CALEIRAS

Gutters / Gouttières / Canallones



### TERRAÇOS

Terraces / Terrasses / Terrazas



### FACHADAS

Facades / Façades / Fachadas



### FLOREIRAS

Flower pots / Pots de fleurs / Jardinera



# Selante Acrílico

Acrylic Sealant / Mastic Acrylique / Sellante Acrílico

O Selante Acrílico é um produto monocomponente, com base numa dispersão acrílica. É um selante que não escorre, inodoro e não provoca corrosão nos metais.

Após a aplicação, o produto forma uma película elástica, devido à evaporação da água contida no selante.

Este produto foi desenvolvido para aplicar em juntas interiores sujeitas a pouco movimento e para preenchimento de fissuras em interiores e exteriores (desde que não estejam imersas em água).

#### Características

- Grande facilidade de aplicação, libertando pouco odor;
- Boa adesão em substratos como betão, alvenaria, madeira pintada, alumínio anodizado e PVC;
- Capacidade de movimentação <10%;
- Após curado, forma uma película à prova de água;
- Resistente a intempéries e à chuva;
- Pintável, não contém óleos;
- Elevada durabilidade;
- Não corrosivo;
- Validade: 12 meses.

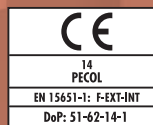

**i** Dados técnicos e ficha de segurança disponível sob pedido.  
/ Technical information and safety data sheet available under request / Données techniques et fiche de sécurité disponible sur demande / Datos técnicos y ficha de seguridad disponible bajo pedido  
dep.tecnico@pecol.pt

Pecol Acrylic Sealant is a plastic one part sealant, based on acrylic dispersion. Is a non sag sealant, almost odour free and is not corrosive towards metals.

The product is designed for internal low movement joints and interior and exterior crack filling with no permanent water immersion.

After application, the product forms a soft plastic elastic rubber by evaporation of water from the sealant.

#### Characteristics

- Very easy application with low odour;
- Good adhesion to substrates such as concrete, brickwork, painted wood, anodised aluminium and UPVC;
- Movement capability <10%;
- Form a permanent water repellent layer after curing;
- Resistant to weather and rain;
- Paintable, contains no oil;
- High durability;
- No corrosive;
- Shelf Life: 12 months.

Mastic Acrylique est un produit mono-composant, plasto-élastique, bas module à base de dispersion acrylique. C'est un mastic qui ne rétrécit pas, inodore et ne provoque pas de corrosion sur les métaux.

Après application, le produit forme une pellicule élastique due à l'évaporation de l'eau contenue dans le mastic. Ce produit a été développé pour les joints intérieurs soumises à peu de mouvement et pour le remplissage de fissures en intérieurs et extérieurs (dès qu'ils ne soient pas immergés d'eau).

#### Caractéristiques

- Facile d'appliquer et libérant peu d'odeur;
- Haute adhésion sur des supports comme le béton, maçonnerie, bois peint, aluminium anodisé et PVC;
- Capacité de mouvement: 10% maxi;
- Après l'endurissement, il forme une pellicule étanche;
- Résistante aux intempéries et à la pluie;
- Peut être peint;
- Haut durabilité;
- Pas corrosif;
- Validité: 12 mois.

El Sellante Acrílico es un producto monocomponente, con base en una dispersión acrílica. Es un sellante que no escurre, inodoro y no provoca corrosión en los metales.

Tras la aplicación, el producto forma una película elástica, debido a la evaporación del agua contenida en el sellante. Este producto fue desarrollado para ser aplicado en juntas interiores sujetas a poco movimiento y para rellenar fisuras en interiores y exteriores (desde que no estén inmersas en agua).

#### Características

- Gran facilidad de aplicación, liberando poco olor;
- Buena adhesión en sustratos como hormigón, alvenaria, madera pintada, aluminio anodizado y PVC;
- Capacidad de movilización <10%;
- Tras la cura, forma una película resistente al agua;
- Resistente a la intemperie y lluvia;
- Pintable, no contiene aceites;
- Elevada durabilidad;
- No corrosivo;
- Caducidad: 12 meses.



CÓDIGO CODE / CODE / CÓDIGO	COR** COLOR / COULEUR / COLOR	CAPACIDADE CAPACITY / CAPACITÉ / CAPACIDAD	EMBALAGEM QUANTITY / EMBALLAGE / EMBALAJE	QTD. PALETE PALET / QT. PALLETTE / CANT. PALÉ	
002701000000	Branco / white / Blanc / Blanco	9003	310 ml	25	900
002702000000	Cinza / Grey / Gris / Gris	7004	310 ml	25	900

\*\* Cor do produto aproximada à cor RAL / The color of the product is close to color RAL / Couleur du produit similaire a couleur RAL / Color del producto aproximada al color RAL





# VEDAÇÃO E COLAGEM

Sealing and Bonding / Étanche et Collage / Sellado y Pegado

## Selante Madeira

Wood Sealant / Mastic Bois / Sellante Madera



Isento de silicone e solventes, o Selante de Madeira é um produto monocomponente, com base numa mistura de resinas sintéticas em dispersão. Serve para efetuar juntas em soalhos e laminados de cortiça, assim como em madeiras e pisos de madeira.

Este Selante não produz emissões nocivas, logo, é amigo do ambiente.

### Características

- Excelente aderência na maioria dos substratos, tais como betão, madeira envernizada, alumínio e plásticos rígidos, de secagem rápida, podendo ser lixado e pintado;
- Inodoro;
- Resistente à água;
- Produto compatível com tintas e vernizes, não danificando nem diminuindo a aderência e suavidade dos vernizes;
- Cores disponíveis: Carvalho, Faia, Cerejeira, Pinho e Sapelly.

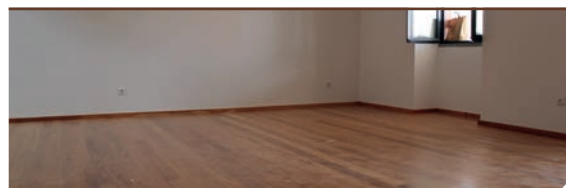

Dados técnicos e ficha de segurança disponível sob pedido.

/ Technical information and safety data sheet available under request / Données techniques et fiche de sécurité disponible sur demande / Datos técnicos y ficha de seguridad disponible bajo pedido dep.tecnico@pecol.pt

Silicone and solvent-free one component sealant, based on a mixture of synthetic resins in dispersion, for sealing joints of parquet, cork laminated as well as wood and wooden floors. The product has no harmful emissions so it is environmentally friendly.

### Characteristics

- The sealant shows excellent adhesion on most substrates like concrete, varnished wood, aluminium and hard plastics, is fast drying, and may be sanded and painted;
- Odorless;
- Water resistant;
- The product is compatible with paints and varnishes and does not damage adherence and smoothness of the varnishes;
- Available colors: Oak, Beech, Cherry, Pine and Sapelly.

Sans silicone et sans solvants, le Mastic à Bois est un produit mono-composant, à base d'un mélange de résines synthétiques en dispersion. Il est utilisé pour jointes sur parquet et liège laminé, ainsi que sur du bois et plancher en bois. Ce mastic ne produit pas d'émissions nocives, il est ami de l'environnement.

### Caractéristiques

- Excellente adhésion sur la majorité des supports, tels que le béton, bois vernis, aluminium et plastique rigide, séchage rapide, peut être poncé et peint.
- Inodore;
- Résistant à l'eau;
- Produit compatible avec des peintures et vernis, n'endommage et ne diminue pas l'adhésion et la douceur des vernis;
- Couleurs disponibles: Chêne, Hêtre, Cerisier, Pin et Sapelly.

Exento de sílicona y solventes, el Sellante de Madera es un producto monocomponente, con base en una mezcla de resinas sintéticas en dispersión. Sirve para efectuar juntas en entarimados y laminados de corcho, así como en maderas y suelos de madera.

Este Sellante no produce emisiones nocivas, por tanto, es respetuoso con el medio ambiente.

### Características

- Excelente adherencia en la mayoría de los sustratos, tales como hormigón, madera embarnizada, aluminio y plásticos rígidos, de cura rápida, pudiendo ser lijado y pintado;
- Inodoro;
- Resistente al agua;
- Producto compatible con pinturas y barnices, no dañando ni disminuyendo la adherencia y suavidad de los barnices;
- Colores disponibles: Roble, Haya, Cerezo, Pino y Sapelly.



CÓDIGO CODE / CODE / CÓDIGO	COR** COLOR / COULEUR / COLOR	CAPACIDADE CAPACITY / CAPACITÉ / CAPACIDAD	EMBALAGEM QUANTITY / EMBALLAGE / EMBALAJE	QTD. PALETE PALET / QT. PALETTE / CANT. PALÉ
003503000000	Pinho / Pine / Pin / Pino	300 ml	6	1134
003505000000	Faia / Beech / Hêtre / Haya	300 ml	6	1134
003504000000	Cerejeira / Cherry / Cerisier / Cerezo	300 ml	6	1134
003501000000	Carvalho / Oak / Chêne / Roble	300 ml	6	1134
003502000000	Sapelly / Sapelly / Sapelly / Sapelly	300 ml	6	1134

\*\* Cor do produto aproximada à cor RAL / The color of the product is close to color RAL / Couleur du produit similaire a couleur RAL / Color del producto aproximada al color RAL





# Cola para Sancas e Molduras

Construction Adhesive Solvent-free / Colle pour Corniches et Moulures / Adhesivo para Cornisas y Molduras

A Cola para Sancas e Molduras PECOL é uma cola de base aquosa, livre de solventes, com elevado poder de colagem. Este produto cura por evaporação da água, permitindo uma colagem forte, duradoura e com boa resistência à humidade.

#### Características

- Livre de Solventes;
- Boa capacidade de preenchimento em superfícies irregulares;
- Aplicação direta no substrato;
- Resistente à humidade;
- Pintável;
- Cor: Branca;
- Validade: 12 meses.

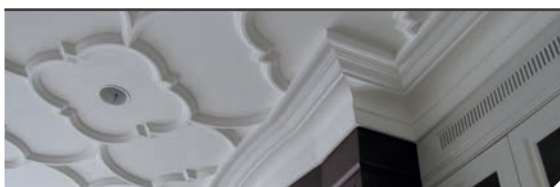

**i** Dados técnicos e ficha de segurança disponível sob pedido.  
/ Technical information and safety data sheet available under request / Données techniques et fiche de sécurité disponible sur demande / Datos técnicos y ficha de seguridad disponible bajo pedido  
dep.tecnico@pecol.pt

The construction adhesive is a versatile emulsion-based, solvent-free adhesive, with a high bond strength. The product cures by evaporation of water and forms a strong, durable, moisture resistant bonding.

#### Characteristics

- Solvent-free;
- Gap-filling properties when bonding on uneven surfaces;
- Direct application to one substrate;
- Moisture resistant;
- Can be painted over;
- Colour: white;
- Shelf Life: 12 months.

La Colle pour Corniches et Moulures est une colle de base aqueuse, sans solvant, avec un pouvoir de collage élevé. Ce produit durcit par évaporation d'eau, permet un collage fort, durable et avec une bonne résistance à l'humidité.

#### Caractéristiques

- Sans Solvants;
- Bonne capacité de remplissage sur surfaces irrégulières;
- Application directe sur le support;
- Résistant à l'humidité;
- Peut être peinté;
- Couleur: Blanc;
- Validité: 12 mois.

El Adhesivo para Cornisas y Molduras PECOL es un adhesivo de base acuosa, libre de solventes, con elevado poder de adhesión. Este producto cura por evaporación del agua, permitiendo un pegado fuerte, duradero y con buena resistencia a la humedad.

#### Características

- Libre de Solventes;
- Buena capacidad de relleno en superficies irregulares;
- Aplicación directa en el material;
- Resistente a la humedad;
- Pintable;
- Color: Blanco;
- Caducidad: 12 meses.



CÓDIGO CODE / CODE / CÓDIGO	COR** COLOR / COULEUR / COLOR	9003	CAPACIDADE CAPACITY / CAPACITÉ / CAPACIDAD	EMBALAGEM QUANTITY / EMBALLAGE / EMBALAJE	QTD. PALETE PALET / QT. PALETTE / CANT. PALÉ
006005000000	Branco / white / Blanc / Blanco		310 ml	12	1200

\*\* Cor do produto aproximada à cor RAL / The color of the product is close to color RAL / Couleur du produit similaire à couleur RAL / Color del producto aproximada al color RAL





# VEDAÇÃO E COLAGEM

Sealing and Bonding / Étanche et Collage / Sellado y Pegado

## Cola de Montagem Premium

Adhesive Montage Glue Premium / Colle Montage Premium / Adhesivo Montaje Premium



A Cola de Montagem Premium Pecol é um adesivo à base de neoprene, com uma elevada viscosidade, grande poder de aderência e uma fixação inicial muito forte.

É um produto de fácil aplicação através de uma pistola de silicone tradicional e com uma secagem rápida. Especialmente adequado para fixar materiais como madeira, betão, plástico, pedra, PVC e azulejo. Aplica-se facilmente em todo o tipo de materiais porosos.

### Características

- Elevadíssimo poder de agarre inicial;
- Aplicação direta no substrato;
- Resistente à humidade;
- Pintável com tintas aquosas;
- Boa capacidade de preenchimento, ideal para superfícies irregulares;
- Validade: 12 meses.

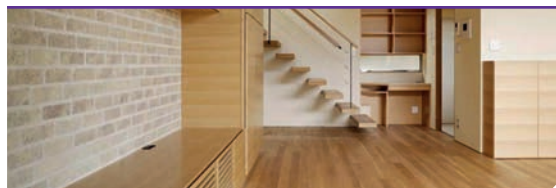

Dados técnicos e ficha de segurança disponível sob pedido.

/ Technical information and safety data sheet available under request / Données techniques et fiche de sécurité disponible sur demande / Datos técnicos y ficha de seguridad disponible bajo pedido dep. tecnico@pecol.pt

Montage Glue Pecol is a neoprene based adhesive with high viscosity, powerful bond strength and an extremely high initial setting. It is a product easy to apply by means of a traditional caulking gun, with a quick drying and does not make strings. Special suitable for fixing materials such as wood, concrete, plastic, stone, PVC and tiles.

### Characteristics

- Extremely high initial grab;
- Direct application on substrate;
- Moisture resistant;
- Can be painted over;
- Gap-filling properties when bonding on uneven surfaces;
- Shelf Life: 12 months.

La colle de montage Premium Pecol est un adhésif à la base de néoprène, avec une haute viscosité, grand pouvoir de adhésion et une prise initiale très fort. Ce produit est de facile application à l'aide d'un pistolet à mastic traditionnel et de séchage rapide.

Spécialement adapté pour fixer des matériaux comme le bois, béton, plastique, pierre, PVC et carrelage. De facile application sur tous types de matériaux poreux.

### Caractéristiques

- Très fort pouvoir de saisie initiale;
- Application directe sur le support;
- Résistante à l'humidité;
- Peut être peinte avec des peintures aqueuses;
- Bonne capacité de remplissage, idéale pour les surfaces irrégulières;
- Validité: 12 mois.

La Cola de Montaje Premium Pecol es un adhesivo a base de neopreno con una alta viscosidad, gran poder de adherencia y una fijación inicial muy fuerte. Es un producto de fácil aplicación a través de una pistola de silicona tradicional y con una cura rápida.

Especialmente adecuado para fijar materiales como madera, hormigón, plástico, piedra, PVC y azulejo. Se aplica fácilmente y en todo tipo de materiales porosos.

### Características

- Elevadísimo poder de agarre inicial;
- Aplicación directa en el material;
- Resistente a la humedad;
- Pintable con pinturas acuosas;
- Buena capacidad de relleno, ideal para superficies irregulares;
- Caducidad: 12 meses.

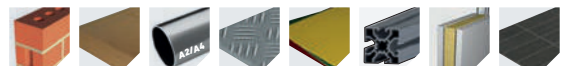

CÓDIGO CODE / CODE / CÓDIGO	COR** COLOR / COULEUR / COLOR	CAPACIDADE CAPACITY / CAPACITÉ / CAPACIDAD	EMBALAGEM QUANTITY / EMBALLAGE / EMBALAJE	QTD. PALETE PALET / QT. PALETTE / CANT. PALÉ
006003000000	Bege / Beige / Beige / Bege	310 ml	25	1200

\*\* Cor do produto aproximada à cor RAL / The color of the product is close to color RAL / Couleur du produit similaire à couleur RAL / Color del producto aproximada al color RAL



# Prego Líquido Special

Liquid Nail Special / Clou Liquide Special / Clavo Líquido Special

O Prego Líquido Special Pecol é um adesivo à base de solventes, com elevado nível de viscosidade, com uma grande aderência e uma fixação inicial muito forte.

É um produto de fácil aplicação através de uma pistola de silicone tradicional e com uma secagem rápida. Especialmente adequado para fixar uma vasta gama de materiais de construção, tais como madeira, betão, plástico, pedra, PVC e azulejo.

#### Características

- Elevadíssimo poder de agarre inicial;
- Aplicação direta no substrato;
- Resistente à humidade;
- Boa capacidade de preenchimento, ideal para superfícies irregulares.



Dados técnicos e ficha de segurança disponível sob pedido.

/ Technical information and safety data sheet available under request / Données techniques et fiche de sécurité disponible sur demande / Datos técnicos y ficha de seguridad disponible bajo pedido

dep.technico@pecol.pt

Liquid Nail is a solvent based adhesive with high viscosity, strong bond strength and high initial setting.  
It is a product easy to apply using a traditional caulking gun, with a quick drying and does not make strings. Specially suitable for fixing a wide range of construction materials, such as: wood, concrete, plastic, stone, PVC and tiles.

#### Characteristics

- Strong initial grab;
- Direct application on substrate;
- Moisture resistant;
- Gap-filling properties when bonding on uneven surfaces.

Le Clou Liquide Special est un adhésif à base de solvant, avec un niveau de viscosité élevé, un grand pouvoir d'adhésion et une fixation initiale très forte.  
Ce produit est de facile application à l'aide d'un pistolet à mastic traditionnel et de séchage rapide.

Spécialement adéquat pour fixer une vaste gamme de matériaux de construction comme le bois, béton, plastique, pierre, PVC et carrelage.

#### Caractéristiques

- Très fort pouvoir de saisie initiale;
- Application directe sur le support;
- Résistante à l'humidité;
- Bonne capacité de remplissage, idéale pour les surfaces irrégulières.

El Clavo Líquido Special Pecol es un adhesivo a base de solventes, con elevado nivel de viscosidad, con una gran adherencia y una fijación inicial muy fuerte.

Es un producto de fácil aplicación a través de una pistola de silicona tradicional y con una cura rápida.

Especialmente adecuado para fijar una vasta gama de materiales de construcción, tales como madera, hormigón, plástico, piedra, PVC y azulejo.

#### Características

- Elevadísimo poder de agarre inicial;
- Aplicación directa en el sustrato;
- Resistente a la humedad;
- Buena capacidad de relleno, ideal para superficies irregulares.



CÓDIGO CODE / CODE / CÓDIGO	COR** COLOR / COULEUR / COLOR	CAPACIDADE CAPACITY / CAPACITÉ / CAPACIDAD	EMBALAGEM QUANTITY / EMBALLAGE / EMBALAJE	QTD. PALETTE PALET / QT. PALETTE / CANT. PALE
006001000000	Bege / Beige / Beige / Bege	300 ml	25	1200

\*\* Cor do produto aproximada à cor RAL / The color of the product is close to color RAL / Couleur du produit similaire a couleur RAL / Color del producto aproximada al color RAL





# VEDAÇÃO E COLAGEM

Sealing and Bonding / Étanche et Collage / Sellado y Pegado

## Cola PU Express Multifibras Premium

Express PU Multifibre Structural Glue Premium / Colle de PU structurel multifibres Express Premium / Cola de PU Estructural Express Multifibras Premium



EN 204 D4



Cola estrutural à base de PU reforçada com fibra de vidro com elevado poder de colagem e secagem rápida. Excelente resistência às condições atmosféricas, variações térmicas e humidade. Indicado para colagem de uniões em madeira, alumínio, pedras naturais, cerâmica, metal, poliuretano, expostas à intempérie. De acordo com a norma (DIN EN 204 D4) e (DIN 14257 D4 standard).

### Características

- Pode ser pintado e polido após curado;
- Resistente à chuva e aos raios U.V.;
- Inodoro;
- Excelente resistência ao envelhecimento;
- Resistente a água salina e água doce;
- Isento de solventes;
- Isento de silicone;
- Excelente tixotropia, não escorre;
- Expande durante o processo de cura.



Dados técnicos e ficha de segurança disponível sob pedido.

/ Technical information and safety data sheet available under request / Données techniques et fiche de sécurité disponible sur demande / Datos técnicos y ficha de seguridad disponible bajo pedido  
dep.tecnico@peco.pt

Structural glue PU based reinforced with glass fiber with high power of gluing and fast drying. Excellent weather resistance, thermal and moisture variations. Suitable for gluing joints of wood, aluminum, natural stone, ceramic, metal, polyurethane, exposed to weathering. According to the standards (DIN EN 204 D4) and (D4 DIN 14257).

### Characteristics

- It can be painted and polished after cured;
- Resistant to rain and UV-rays;
- Odourless;
- Excellent resistance to ageing;
- Resistant to saline and fresh water;
- Solvent-free;
- Silicone-free;
- Excellent thixotropy, it does not drain;
- Expands during the curing process.

Colle de PU structurel à base de fibre de verre renforcée avec un fort pouvoir de collage et séchage rapide. Excellente résistance aux intempéries, aux variations thermiques et humidité. Adéquat pour collages en bois, aluminium, pierre naturelle, céramique, métal et polyuréthane, exposés aux intempéries. En accord avec la norme (DIN EN 204 D4) et (DIN 14257 D4 standard).

### Caractéristiques

- Peut être peint et poli après durcissement;
- Résistant à la pluie et rayons U.V.;
- Inodore;
- Excellente résistance au vieillissement;
- Résistant à l'eau salée et l'eau douce;
- Sans solvants;
- Sans silicone;
- Excellente thixotropie, ne coule pas;
- Se dilate pendant le processus de durcissement.

Pegamento estrutural a base de PU reforçada com fibra de vidro com un alto poder de pegado y secado rápido. Excelente resistencia a la intemperie, las variaciones térmicas y de humedad. Adecuado para uniones de madera, aluminio, piedra natural, cerámica, metal, poliuretano, expuestas a la intemperie. De acuerdo con la norma (DIN EN 204 D4) y (D4 DIN 14257 estándar).

### Características

- Puede ser pintado y pulido después de curado;
- Resistente a la lluvia y los rayos U.V.;
- Inodoro;
- Excelente resistencia al envejecimiento;
- Resistente a agua salada y dulce;
- Exento de solventes;
- Exento de silicona;
- Excelente tixotropía, no gotea;
- Expande durante el proceso de curado.

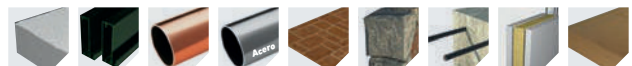

CÓDIGO CODE / CODE / CÓDIGO	COR** COLOR / COULEUR / COLOR	CAPACIDADE CAPACITY / CAPACITÉ / CAPACIDAD	EMBALAGEM QUANTITY / EMBALLAGE / EMBALAJE	QTD. PALETE PALET / QT. PALETTE / CANT. PALÉ
005901000000	Beige / Beige / Beige / Bege	300 ml	12	900

\*\* Cor do produto aproximada à cor RAL / The color of the product is close to color RAL / Couleur du produit similaire à couleur RAL / Color del producto aproximada a color RAL



# Selante Refratário

Fire Sealant 1200°C / Mastic Réfractaire / Sellante Refractario

O Selante Refratário é um produto de elevada qualidade, com base pastosa, que ao curar forma uma junta rígida que resiste a temperaturas até +1200°C. Produto adequado para aplicações em betão, metal e tijolo.

#### Características

- Pronto a utilizar;
- Não se desfaz nem estala após o endurecimento
- Resiste a temperaturas até +1200°C;
- Não encolhe após a cura;
- Isento de amianto;
- Cor antracite.



#### **i** Dados técnicos e ficha de segurança disponível sob pedido.

/ Technical information and safety data sheet available under request / Données techniques et fiche de sécurité disponible sur demande / Datos técnicos y ficha de seguridad disponible bajo pedido  
dep.tecnico@pecol.pt

Pecol Fire Sealant is a high quality sealing paste based, which cures to form a hard joint which withstand temperatures of up to 1200°C. Suitable for application on concrete, metal and bricks.

#### Characteristics

- Ready for use;
- Does not crumble or crack after hardening;
- Heat resistant until 1200°C;
- Free of asbestos;
- No shrinkage after cure;
- Color: anthracite.

Le Mastic Réfractaire est un produit de haute qualité, de base pâteuse qui forme une jointe rigide résistante à des températures jusqu'à +1200°C après durcir. Ce produit est adéquat pour des applications en béton, métal et briques.

#### Caractéristiques

- Prêt à l'emploi;
- Ne se défail pas et ne se fend pas après durcir ;
- Résiste à des températures jusqu'à +1200°C;
- Ne rétrécit pas après durcir;
- Sans amiante;
- Couleur: anthracite.

El Sellante Refractario es un producto de elevada calidad con base pastosa, que al secar forma una junta rígida que resiste a temperaturas hasta +1200°C. Producto adecuado para aplicaciones en hormigón, metal y ladrillo.

#### Características

- Listo para utilizar;
- No se deshace ni estalla tras endurecer
- Resiste a temperaturas hasta +1200°C;
- No encoje tras la cura;
- Exento de amianto;
- Color antracite.



**CÓDIGO**  
CODE / CODE /  
CÓDIGO

**COR\*\***  
COLOR / COULEUR / COLOR

**CAPACIDADE**  
CAPACITY /  
CAPACITÉ /  
CAPACIDAD

**EMBALAGEM**  
QUANTITY /  
EMBALLAGE /  
EMBALAJE

**QTD. PALETE**  
PALET /  
QT. PALETTE /  
CANT. PALÉ

002402000000

Antracite / Anthracite / Anthracite / Antracite

310 ml

12

900

\*\* Cor do produto aproximada à cor RAL / The color of the product is close to color RAL / Couleur du produit similaire à couleur RAL / Color del producto aproximada al color RAL





# VEDAÇÃO E COLAGEM

Sealing and Bonding / Étanche et Collage / Sellado y Pegado

## Espuma Poliuretano B2 Premium

Polyurethane Foam B2 Premium / Mousse Polyuréthane B2 Premium / Espuma Poliuretano B2 Premium



DIN 4102-1



A Espuma de Poliuretano B2 Premium é um produto mono componente, pronto a utilizar, de alta qualidade, que expande e cura em contacto com a água e a humidade do ar, proporcionando aplicações com excelente resistência ao calor, frio, envelhecimento e a muitos produtos químicos.

Os gases propulsores utilizados são inofensivos para a camada de ozono (CFC free). Tem na classificação de resistência ao fogo B2 (DIN 4102 - Parte2) — auto extingüível.

### Características

- Excelente adesão em todos os materiais (exceto PE, PP, PTFE e silicones);
- Rendimento aproximado de 45 litros;
- Elevadas performances no isolamento acústico e térmico;
- Grande poder de enchimento;
- Excelente estabilidade dimensional. Não tem contração de volume nem expansão posterior;
- Prazo de validade prolongado: 12 meses.

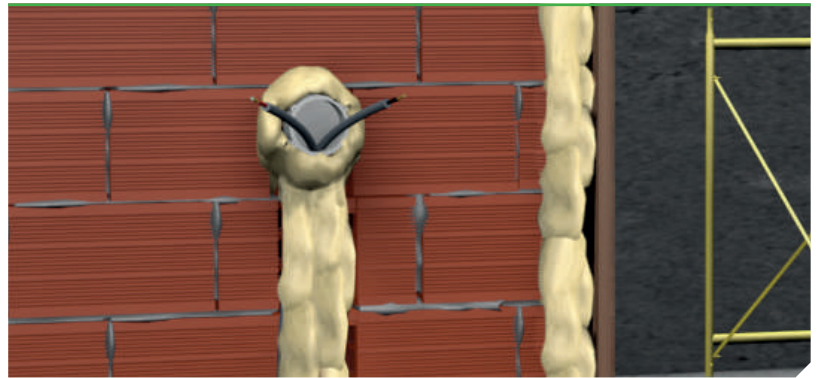

Dados técnicos e ficha de segurança disponível sob pedido.

Technical information and safety data sheet available under request / Données techniques et fiche de sécurité disponible sur demande / Datos técnicos y ficha de seguridad disponible bajo pedido

dep.technico@pecol.pt

PU Foam B2 Premium is a one component, self expanding, ready to use polyurethane foam. The foam cures with the humidity from the air and from building materials. It offers excellent resistance to age, heat, cold and most chemicals. It contains CFC free propellants which are completely harmless to the ozone layer. The fire class resistance is a B2 (DIN 4102 - Part2) — self extinguishing.

### Characteristics

- Excellent adhesion on most substrates;
- High foam yield up to 45 liters;
- High thermal and acoustical insulation;
- Very good filling and mounting capacities;
- Excellent stability. No shrinkage or post expansion;
- The fully cured foam resists temperatures from -30°C to +80°C;
- Long shelf life: 12 months.

La Mousse de Polyuréthane B2 Premium est un produit mono-composant, prêt à utiliser, de haute qualité, qui se répand et durcit en contact avec l'eau et l'humidité de l'air, proportionnant des applications avec une excellente résistance à la chaleur, froid, vieillissement et à plusieurs produits chimiques. Les gaz propulseur utilisés sont inoffensifs pour la couche d'ozone (CFC free). Elle est auto-extinguible dans la classification de résistance au feu B2 (DIN 4102 - Partie 2).

### Caractéristiques

- Excellente adhésion sur tous les matériaux (à l'exception de PE, PP, PTFE et silicones);
- Rendement approximatif de 45 litres;
- Hautes performances dans l'isolation acoustique et thermique;
- Grand pouvoir de remplissage;
- Excellente stabilité dimensionnelle. Ne contracte pas de volume ni augmente postérieurement;
- Validité prolongée: 12 mois.

La Espuma de Poliuretano B2 Premium es un producto monocomponente, listo para utilizar, de alta calidad, que expande y cura en contacto con el agua y la humedad del aire, proporcionando aplicaciones con excelente resistencia al calor, frío, envejecimiento y a muchos productos químicos. Los gases propulsores utilizados son inofensivos para la capa de ozono (CFC free). Tiene en la clasificación de resistencia al fuego B2 (DIN 4102 - Parte2) — autoextinguible.

### Características

- Excelente adhesión en todos los materiales (excepto PE, PP, PTFE y siliconas);
- Rendimento aproximado a 45 litros;
- Elevadas prestaciones en aislamiento acústico y térmico;
- Gran poder de relleno;
- Excelente estabilidad dimensional. No tiene contracción de volumen ni expansión posterior;
- Fecha de caducidad prolongada: 12 meses.



CÓDIGO CODE / CODE / CÓDIGO	TIPO TYPE / TIPO / TIPO	COR** COLOR / COULEUR / COLOR	CAPACIDADE CAPACITY / CAPACITÉ / CAPACIDAD	EMBALAGEM QUANTITY / EMBALLAGE / EMBALAJE	QTD. PALETE PALET / QT. PALLETTE / CANT. PALÉ
002101000000	Manual / Manual / Manuel / Manual	Bege / Beige / Beige / Beige	750 ml	12	840
002102000000	Pistolável / Gun / Pistolable / Pistolable	Bege / Beige / Beige / Beige	750 ml	12	840

JAR 1000 le ebomimomq otobomq leb 10000 \ JAR 1000 le ebomimomq otobomq leb 10000 \ JAR 1000 le ebomimomq otobomq leb 10000 \ JAR 1000 le ebomimomq otobomq leb 10000 \ JAR 1000 le ebomimomq otobomq leb 10000 \ JAR 1000 le ebomimomq otobomq leb 10000



# Espuma Poliuretano B3 Special

Polyurethane Foam B3 Special / Mousse Polyuréthane B3 Special / Espuma Poliuretano B3 Special

A Espuma de Poliuretano B3 Special é um produto monocomponente, pronto a utilizar, de alta qualidade e de auto expansão, para instalações e isolamentos. Este produto cura e expande em contacto com água e humidade do ar. Esta Espuma apresenta uma estrutura homogénea, com uma excelente capacidade de expansão e elevada resistência ao envelhecimento, ao frio e à maioria dos produtos químicos. Contém propulsores livres de CFC, que são completamente inofensivos para a camada de ozono.

#### Características

- Excelente adesão em todos os materiais (exceto PE, PP, PTFE e silicões);
- Rendimento aproximado de 45 litros;
- Elevadas performances no isolamento acústico e térmico;
- Grande poder de enchimento;
- Excelente estabilidade dimensional. Não tem contração de volume nem expansão posterior;
- A espuma depois de curada resiste a temperaturas entre os -30°C e os +80°C;
- Classe de Inflamabilidade (DIN 4102): B3;
- Prazo de Validade: 12 meses.



**i** Dados técnicos e ficha de segurança disponível sob pedido.  
/ Technical information and safety data sheet available under request / Données techniques et fiche de sécurité disponible sur demande / Datos técnicos y ficha de seguridad disponible bajo pedido  
dep.tecnico@pecol.pt



DIN 4102

PU Foam B3 Special is a one component, self expanding, ready to use polyurethane foam for installation and insulation purposes. The product cures by the reaction with humidity from the air. The foam has homogenous structure, excellent expansion capacity and high resistance to age, cold and most chemicals. It contains CFC free propellants which are completely harmless to the ozone layer.

#### Characteristics

- Excellent adhesion on most substrates;
- High foam yield up to 45 liters;
- High thermal and acoustical insulation;
- Very good filling and mounting capacities;
- Excellent stability. No shrinkage or post expansion;
- The fully cured foam resists temperatures from -30°C to +80°C;
- Flammability class (DIN 4102): B3;
- Long shelf life: 12 months.

La Mousse Polyuréthane B3 Special est un produit mono-composant, prêt à utiliser, de haute qualité et d'auto-expansion, pour des installations et isolations. Ce produit durcit et s'expand avec de l'eau et l'humidité de l'air. Cette Mousse présente une structure homogène, avec une excellente capacité d'expansion et une résistance élevée au vieillissement, au froid et à la plupart des produits chimiques. Elle contient des propulseurs libres de CFC, qui sont complètement inoffensifs pour la couche d'ozone.

#### Caractéristiques

- Excellente adhésion sur tous les matériaux (à l'exception de PE, PP, PTFE et silicões);
- Rendement approximatif de 45 litres;
- Hautes performances dans l'isolation acoustique et thermique;
- Grand pouvoir de remplissage;
- Excellente stabilité dimensionnelle. Ne contracte pas de volume ni augmente postérieurement;
- Après durcir, la Mousse résiste à des températures comprises entre -30°C et +80°C;
- Classe d'Inflamabilité (DIN 4102): B3;
- Validité: 12 mois.

La Espuma de Poliuretano B3 Special es un producto monocomponente, listo para utilizar, de alta calidad y de autoexpansión, para instalaciones y aislamientos. Este producto se cura y expande en contacto con el agua y humedad del aire. Esta Espuma presenta una estructura homogénea, con una excelente capacidad de expansión y elevada resistencia al desgaste, al frío y a la mayoría de los productos químicos. Contiene propulsores libres de CFC, que son completamente inofensivos para la capa de ozono.

#### Características

- Excelente adhesión en todos los materiales (excepto PE, PP, PTFE y silicões);
- Rendimiento aproximado a 45 litros;
- Elevadas prestaciones en el aislamiento acústico y térmico;
- Gran poder de relleno;
- Excelente estabilidad dimensional. No tiene contracción de volumen ni expansión posterior;
- La espuma después de curada resiste a temperaturas entre los -30°C y los +80°C;
- Clase de Inflamabilidad (DIN 4102): B3;
- Fecha de caducidad: 12 meses.



CÓDIGO CODE / CODE / CÓDIGO	TIPO TYPE / TIPO / TIPO	COR** COLOR / COULEUR / COLOR	CAPACIDADE CAPACITY / CAPACITÉ / CAPACIDAD	EMBALAGEM QUANTITY / EMBALLAGE / EMBALAJE	QTD. PALETE PALET / QT. PALLETTE / CANT. PALÉ
002101000001	Manual / Manual / Manuel / Manual	Bege / Beige / Beige / Bege	750 ml	12	840
002102000001	Pistolável / Gun / Pistolable / Pistolable	Bege / Beige / Beige / Bege	750 ml	12	840

\*\* Cor do produto aproximada à cor RAL / The color of the product is close to color RAL / Couleur du produit similaire a couleur RAL / Color del producto aproximada al color RAL





# VEDAÇÃO E COLAGEM

Sealing and Bonding / Étanche et Collage / Sellado y Pegado

## Pistola para Silicone Special

Caulking Gun Special / Pistolet à Mastic Special / Pistola para Silicona Special



CÓDIGO CODE / CODE / CÓDIGO	RÁCIO RATIO / RATIO / RATIO	CAPACIDADE CAPACITY / CAPACITÉ / CAPACIDAD	EMBALAGEM QUANTITY / EMBALLAGE / EMBALAJE
00500200000	1:28	280 - 310	1



### Para aplicação de selantes e colas de elevada viscosidade

For high and very high viscosity sealants and adhesives

Pour application de mastic et colles de haute viscosité

Para aplicación de sellantes y adhesivos de elevada viscosidad

## Pistola para Silicone Classic

Caulking Gun Classic / Pistolet à Mastic Classic / Pistola para Silicona Classic

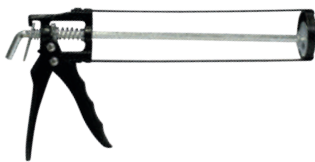

CÓDIGO CODE / CODE / CÓDIGO	RÁCIO RATIO / RATIO / RATIO	CAPACIDADE CAPACITY / CAPACITÉ / CAPACIDAD	EMBALAGEM QUANTITY / EMBALLAGE / EMBALAJE
00500100000	1:20	280 - 310	1



### Para aplicação de selantes e colas de elevada viscosidade

For high and very high viscosity sealants and adhesives

Pour application de mastic et colles de haute viscosité

Para aplicación de sellantes y adhesivos de elevada viscosidad

## Pistola para Foils 600 ml

Aluminium Foils 600 ml Gun Applicator / Pistolet à Sachets 600 ml / Pistola para Foils 600 ml



CÓDIGO CODE / CODE / CÓDIGO	RÁCIO RATIO / RATIO / RATIO	CAPACIDADE CAPACITY / CAPACITÉ / CAPACIDAD	EMBALAGEM QUANTITY / EMBALLAGE / EMBALAJE
00500400000	1:36	600	1



### Para aplicação de selantes e colas de elevada viscosidade

For high and very high viscosity sealants and adhesives

Pour application de mastic et colles de haute viscosité

Para aplicación de sellantes y adhesivos de elevada viscosidad

## Pistola para Foils 310 ml

Aluminium Foils 310 ml Gun Applicator / Pistolet à Sachets 310 ml / Pistola para Foils 310 ml



CÓDIGO CODE / CODE / CÓDIGO	RÁCIO RATIO / RATIO / RATIO	CAPACIDADE CAPACITY / CAPACITÉ / CAPACIDAD	EMBALAGEM QUANTITY / EMBALLAGE / EMBALAJE
00500400001	1:26	310	1



### Para aplicação de selantes e colas de elevada viscosidade

For high and very high viscosity sealants and adhesives

Pour application de mastic et colles de haute viscosité

Para aplicación de sellantes y adhesivos de elevada viscosidad

## Cartucho Reutilizável ECOSYSTEM

Reusable Cartridge ECOSYSTEM / Cartouche Réutilisable ECOSYSTEM / Cartucho Reutilizable ECOSYSTEM



CÓDIGO CODE / CODE / CÓDIGO	CAPACIDADE CAPACITY / CAPACITÉ / CAPACIDAD	EMBALAGEM QUANTITY / EMBALLAGE / EMBALAJE
0020100000003	300	1



### Mais Económico | Mais Ecológico | Mais Versátil

Economical | Ecological | Versatility

Plus Économique | Plus Écologique | Plus Versatilité

Más Económico | Más Ecológico | Más Versátil





## Pistola para PU Teflon Special

Teflon Gun Special / Pistolet à PU Téflon Special / Pistola para PU Teflon Special



CÓDIGO CODE / CODE / CÓDIGO	EMBALAGEM QUANTITY / EMBALLAGE / EMBALAJE
002500030000	1



**Para aplicação de espuma de poliuretano**  
For usage with PU foam gun  
Pour application de la mousse de polyuréthane  
Para la aplicación de espuma de poliuretano

## Pistola para PU Special

Gun Special / Pistolet à PU Special / Pistola para PU Special



CÓDIGO CODE / CODE / CÓDIGO	EMBALAGEM QUANTITY / EMBALLAGE / EMBALAJE
002500070000	1



**Para aplicação de espuma de poliuretano**  
For usage with PU foam gun  
Pour application de la mousse de polyuréthane  
Para la aplicación de espuma de poliuretano

## Pistola para PU Classic

Gun Classic / Pistolet à PU Classic / Pistola para PU Classic

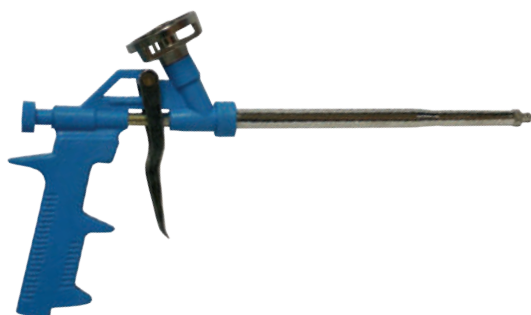

CÓDIGO CODE / CODE / CÓDIGO	EMBALAGEM QUANTITY / EMBALLAGE / EMBALAJE
002500020000	1



**Para aplicação de espuma de poliuretano**  
For usage with PU foam gun  
Pour application de la mousse de polyuréthane  
Para la aplicación de espuma de poliuretano

## Pulverizador para PU

Water sprayer for PU / Vaporisateur pour la mousse PU / Pulverizador para PU



CÓDIGO CODE / CODE / CÓDIGO	CAPACIDADE CAPACITY / CAPACITÉ / CAPACIDAD	EMBALAGEM QUANTITY / EMBALLAGE / EMBALAJE
002111000000	1.2 l	1



**Para adição controlada de água aquando da aplicação de espuma de poliuretano**  
For water sprayer during PU foam application  
Pour rajouter l'eau de façon contrôlée pendant l'application de la mousse de polyuréthane  
Para La adición controlada de agua durante la aplicación de la espuma de poliuretano

## Spray Limpeza Espuma P110

PU Cleaner P110 / Spray Nettoyage Mousse P110 / Spray Limpieza Espuma P110

# P110



CÓDIGO CODE / CODE / CÓDIGO	CAPACIDADE CAPACITY / CAPACITÉ / CAPACIDAD	EMBALAGEM QUANTITY / EMBALLAGE / EMBALAJE	QTD. PALETE PALET / QT. PALETTE / CANT. PALÉ
001011000000	500	12	1044



**Para limpeza do excesso de espuma de poliuretano e manutenção de pistola de aplicação PU**  
For PU foam cleaning and PU foam gun maintenance  
Pour nettoyer la mousse de polyuréthane en excès et pour l'entretien du pistolet d'application de la mousse PU  
Para limpiar el exceso de espuma de poliuretano y mantenimiento de la pistola de aplicación de PU







# PECLOCKS - Bloquear - Selar - Reter - Vedar

ANAEROBIC ADHESIVES - Locking - Sealing - Retaining - Gasketing / ANAEROBIC ADHESIVES - Bloquer - Sceller - retenir - étancher / PECLOCKS - Bloquear - Sellar - Retener

Os Peclocks PECOL (Adesivos e Selantes Anaeróbicos) são produtos de elevada qualidade, com base em resinas de metacrilato especiais, especialmente concebidos para bloquear, fixar, selar e vedar roscas, peças cilíndricas e tubos. Uma das principais características do Peclock é a cura em contacto com metais, mesmo que com ausência de ar. É criada uma junta resistente ao choque e à vibração, e ainda com excelentes capacidades de resistência aos químicos e aos solventes.

Graças à sua consistência líquida, o Peclock preenche completamente os espaços, protegendo de possíveis fugas e corrosões.

#### Características

O Peclock é simples, de fácil aplicação e muito económico. A força e poder deste produto começam a ser verificados alguns minutos após a aplicação, e a força final algumas horas após o uso, isto se aplicado e mantido à temperatura ambiente. O Peclock não necessita de qualquer tipo de mistura ou doseador para aplicar, e tem um desperdício mínimo.

Em muitos aspetos, o Peclock é muito superior à maioria dos produtos convencionais utilizados nas montagens e vedações.



Dados técnicos e ficha de segurança disponível sob pedido.

Technical information and safety data sheet available under request / Données techniques et fiche de sécurité disponible sur demande / Datos técnicos y ficha de seguridad disponible bajo pedido  
dep.tecnico@pecol.pt



Pecol Anaerobic Adhesives and sealants (Peclock) are high quality products based of special methacrylate resins, especially made for economical threadlocking, retaining and sealing of threaded, cylindrical and pipe assemblies.

The characteristic feature of Peclock is the curing in contact with metal while deprived of air. It provides a shock- and vibration-resistant joint, with excellent resistance to chemicals and solvents. Due to its liquid consistency, Peclock completely fills the gaps thus giving protection against leakage and fretting corrosion.

#### Characteristics

Peclock is simple, easy to use and very economical. Handling strength is reached within a few minutes and final strength within a few hours at room temperature. Metering and mixing is not necessary. There is no pot life to be respected and product wastage is minimised.

In many aspects, Peclock is superior to conventional methods of assembly.

Les Peclocks PECOL (Adhésifs et Scellant Anaérobiques) sont des produits de haute qualité, à base de résines de méthacrylate spéciales, spécialement conçus pour bloquer, fixer, sceller et étancher des vis, pièces cylindriques et tubes.

Une des principales caractéristiques de Peclock est le durcissement au contact des métaux, même en l'absence d'air. Un joint de résistance au choc et à la vibration est créé, et a une excellente capacité de résistance aux produits chimiques et aux solvants. Grâce à sa consistance liquide, Peclock remplit complètement les espaces, protégeant de possibles fuites et corrosion.

#### Caractéristiques

Le Peclock est simple, de facile application et très économique. La force et le pouvoir de ce produit commence à se vérifier quelques minutes après l'application, et sa force finale quelques heures après utilisation, si appliqué et maintenu à température ambiante. Le Peclock ne nécessite aucun type de mélange ou doseur pour appliquer, et un gaspillage minimum.

Dans plusieurs aspects, Peclock est supérieur à la plupart des produits conventionnels d'utilisation dans le montage et l'étanchéité.

Los Peclocks PECOL (Adhesivos y Sellantes Anaeróbicos) son productos de elevada calidad, con base en resinas de metacrilato especiales, especialmente concebidos para bloquear, fijar, sellar roscas, piezas cilíndricas y tubos.

Una de las principales características del Peclock es la cura en contacto con metales, incluso con ausencia de aire. Se crea una junta resistente al impacto y a la vibración, además con excelentes capacidades de resistencia a los químicos y a los solventes. Gracias a su consistencia líquida, el Peclock rellena completamente los espacios, protegiendo de posibles fugas y corrosiones.

#### Características

El Peclock es simple, de fácil aplicación y muy económico. La fuerza y poder de este producto empiezan a notarse algunos minutos tras la aplicación, y la fuerza final algunas horas tras el uso, esto al ser aplicado y mantenido a temperatura ambiente. Peclock no necesita ningún tipo de mezcla o dosificador para ser aplicado, y tiene un desperdicio mínimo.

En muchos aspectos, el Peclock es muy superior a la mayoría de los productos convencionales utilizados en montajes y sellados.

**BLOQUEIO DE ROSCAS**  
Threadlocking  
Blocage de filetage  
Bloqueo de roscas

PEC 31243      PEC 31270

**RETIÇÃO DE CONJUNTOS CILÍNDRICOS**  
Retaining cylindrical assemblies  
Rétention d'ensembles cylindriques  
Retención de conjuntos cilíndricos

PEC 31638

**VEDAÇÃO DE TUBOS ROSCADOS E ACESSÓRIOS**  
Sealing of threaded pipes and fittings  
Étanchéité des tubes filetés et accessoires  
Sellado de tubos roscados y accesorios

PEC 31542      PEC 31577

**VEDAÇÃO DE FLANGES**  
Flange sealing, gasketing  
Étanchéité de brides  
Sellado de bridas

PEC 31572



# VEDAÇÃO E COLAGEM

Sealing and Bonding / Étanche et Collage / Sellado y Pegado

PEC 31243

## Peclock bloqueio universal

/ Universal threadlocking type  
/ Peclock blocage universel  
/ Peclock bloqueo universal



CÓDIGO CODE / CODE / CÓDIGO	CAPACIDADE CAPACITY / CAPACITÉ / CAPACIDAD	EMBALAGEM QUANTITY / EMBALLAGE / EMBALAJE
001080004300	50 ml	12

**Bloqueio de roscas**  
Threadlocking  
Blocage de filetage  
Bloqueo de roscas

**Resistência média** / Medium strength / Résistance moyenne / Resistencia media  
**Viscosidade alta** / High viscosity / Haute viscosité / Viscosidad alta

PEC 31270

## Peclock bloqueio permanente de roscas e parafusos

/ Locking of threads and stud bolts  
/ Peclock blocage permanent de filetages et boulons  
/ Peclock bloqueo permanente de roscas y pernos



CÓDIGO CODE / CODE / CÓDIGO	CAPACIDADE CAPACITY / CAPACITÉ / CAPACIDAD	EMBALAGEM QUANTITY / EMBALLAGE / EMBALAJE
001080007000	50 ml	12

**Bloqueio de roscas**  
Threadlocking  
Blocage de filetage  
Bloqueo de roscas

**Resistência média** / Medium strength / Résistance moyenne / Resistencia media  
**Viscosidade média** / Medium viscosity / Moyenne viscosité / Viscosidad media

PEC 31572

## Peclock vedação de juntas

/ Pipe and flange sealing  
/ Peclock étanchéité de joints  
/ Peclock sellado de juntas



CÓDIGO CODE / CODE / CÓDIGO	CAPACIDADE CAPACITY / CAPACITÉ / CAPACIDAD	EMBALAGEM QUANTITY / EMBALLAGE / EMBALAJE
001080007200	50 ml	12

**Vedação de tubos roscados e acessórios | Vedação de flanges**  
Sealing of threaded pipes and fittings | Flange sealing, gasketing  
Étanchéité des tubes filetés et accessoires | Étanchéité de brides  
Sellado de tubos roscados y accesorios | Sellado de bridas

**Resistência média** / Medium strength / Résistance moyenne / Resistencia media  
**Viscosidade alta** / High viscosity / Haute viscosité / Viscosidad alta

PEC 31542

## Peclock vedação hidráulica e pneumática

/ Sealing of hydraulic and pneumatic systems  
/ Peclock étanchéité hydraulique et pneumatique  
/ Peclock sellado hidráulico y neumático



CÓDIGO CODE / CODE / CÓDIGO	CAPACIDADE CAPACITY / CAPACITÉ / CAPACIDAD	EMBALAGEM QUANTITY / EMBALLAGE / EMBALAJE
001080004200	50 ml	12

**Vedação de tubos roscados e acessórios**  
Sealing of threaded pipes and fittings  
Étanchéité des tubes filetés et accessoires  
Sellado de tubos roscados y accesorios

**Resistência média** / Medium strength / Résistance moyenne / Resistencia media  
**Viscosidade média** / Medium viscosity / Moyenne viscosité / Viscosidad media



### Peclock vedação universal p/ tubos e acessórios

/ Universal sealing type for pipes and fittings  
/ Peclock étanchéité universelle p/ tubes et accessoires  
/ Peclock sellado universal para tubos y accesorios

**PEC 31577**

**CÓDIGO**

CODE / CODE / CÓDIGO

001080007700

**CAPACIDADE**

CAPACITY / CAPACITÉ / CAPACIDAD

50 ml

**EMBALAGEM**

QUANTITY / EMBALLAGE / EMBALAJE

12



**Vedação de tubos roscados e acessórios**

Sealing of threaded pipes and fittings  
Étanchéité des tubes filetés et accessoires  
Sellado de tubos roscados y accesorios

**Resistência média** / Medium strength / Résistance moyenne / Resistencia media

**Viscosidade alta** / High viscosity / Haute viscosité / Viscosidad alta



### Peclock retenção de peças cilíndricas sob grandes níveis de esforço dinâmico

/ Retaining cylindrical assemblies under high dynamical stress  
/ Peclock rétention de pièces cylindriques sous grands niveaux d'effort dynamiques  
/ Peclock retención de piezas cilíndricas bajo grandes niveles de esfuerzo dinámico

**PEC 31638**

**CÓDIGO**

CODE / CODE / CÓDIGO

001080003800

**CAPACIDADE**

CAPACITY / CAPACITÉ / CAPACIDAD

50 ml

**EMBALAGEM**

QUANTITY / EMBALLAGE / EMBALAJE

12



**Retenção de conjuntos cilíndricos**

Retaining cylindrical assemblies  
Rétention d'ensembles cylindriques  
Retención de conjuntos cilíndricos

**Resistência alta** / High strength / Résistance haute / Resistencia alta

**Viscosidade média** / Medium viscosity / Moyenne viscosité / Viscosidad media



**31243      31270      31572      31542      31577      31638**

Cor / Color / Couleur / Color	Azul / Blue / Bleu / Azul	Verde / Green / Vert / Verde	Branco / White / Blanc / Blanco	Castanho / Brown / Marron / Marrón	Amarela / Yellow / Jaune / Amarillo	Verde / Green / Vert / Verde
Resistência à Temperatura (°C) / Temperature resistance (°C) / Résistance à la Température (°C) / Resistencia a la Temperatura (°C)	-60°C – +150°C	-60°C – +150°C	-60°C – +150°C	-60°C – +150°C	-60°C – +150°C	-60°C – +150°C
Para Roscas de Diâmetros até / For threaded joints up to / Pour Filetages de Diamètres jusqu'à / Para Roscas de Diâmetros hasta	M36	M20 R $\frac{1}{2}$	M80 R3"	M20 R $\frac{1}{2}$	M80 R3"	M36
Capacidade de Preenchimento (mm) / Gap filling capacity (mm) / Capacité de Remplissage (mm) / Capacidad de Relleno (mm)	0,25	0,15	0,40	0,15	0,50	0,20
Viscosidade a +25°C (Brookfield em mPa) / Viscosity at +25°C Brookfield in mPa / Viscosité à +25°C (Brookfield en mPa) / Viscosidad a +25°C (Brookfield en mPa)	2000 - 7000	500	17000 - 50000	500	24000 - 70000	2500
Tempo até atingir a Resistência Temperatura Ambiente (Horas) / Final strength at room temperature (hours) / Temps à atteindre la Résistance à Température Ambiante (Heures) / Tiempo hasta alcanzar la Resistencia Temperatura Ambiente (Horas)	1 - 3	3 - 6	5 - 10	2 - 4	1 - 3	1 - 3
Força Predominante N/m (Rosca) / Prevailing strength N/m (Thread) / Force Prédominante N/m (Filetage) / Fuerza Predominante N/m (Rosca)	8 - 12	50 - 65	2 - 4	18 - 22	10 - 14	50 - 70
Força de Ruptura N/m (Rosca) / Breakaway strength N/m (Thread) / Force de Rupture N/m (Filetage) / Fuerza de Ruptura N/m (Rosca)	17 - 22	28 - 35	7 - 10	12 - 15	18 - 22	35 - 45
Resistência à Tração N/mm <sup>2</sup> / Shear strength N/mm <sup>2</sup> / Résistance à la Traction N/mm <sup>2</sup> / Resistencia a la Tracción N/mm <sup>2</sup>	9 - 13	15 - 20	4 - 6	8 - 12	6 - 13	25 - 30

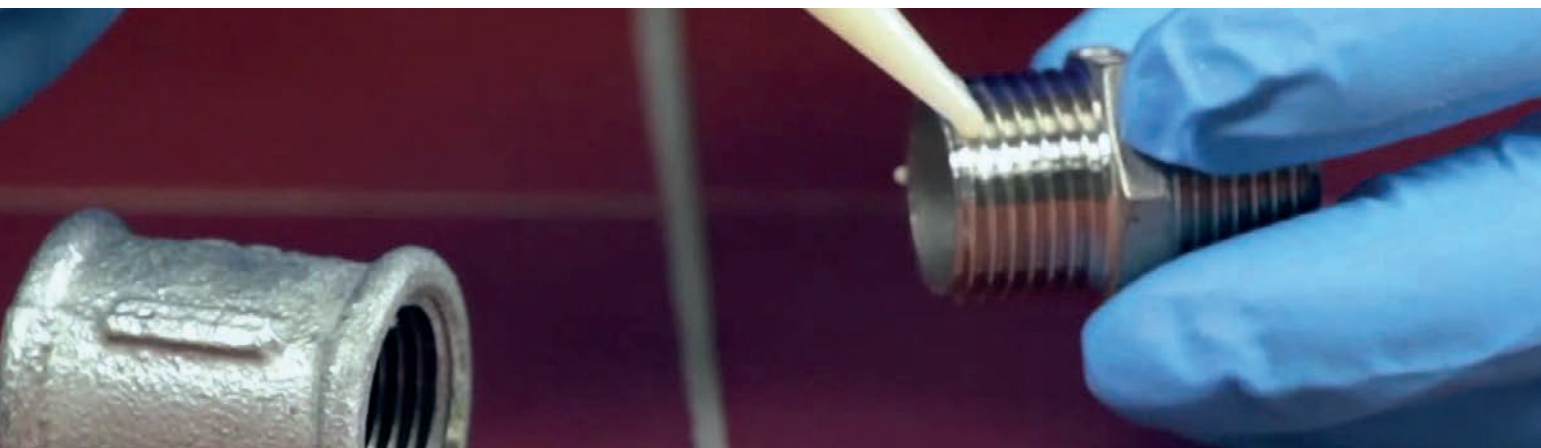



# VEDAÇÃO E COLAGEM

Sealing and Bonding / Étanche et Collage / Sellado y Pegado

## Cola P6 com Ativador

Extra strong adhesive with Activator / Adhésif extra fort avec activateur / Adhesivo extra fuerte con Activador



A Cola P6 é um adesivo com base de cianoacrilato de elevada viscosidade, que juntamente com o Ativador P6 formam um conjunto de alta eficácia para a colagem rápida de diversos materiais.

Este kit tem um excelente poder de aderência e é passível de ser aplicado em superfícies verticais pois não escorre nem cai.

É particularmente indicado para colagens complicadas de substratos porosos ou irregulares, uma vez que aumenta a resistência de colagem, evitando que a cola seja absorvida pelo substrato.

### Características

- Base: monómero de etil-2-cianoacrilato;
- Aparência: Clara, transparente quando líquida;
- Densidade: 1,06 g/cm<sup>3</sup>;
- Validade: 12 meses, fechado na embalagem;
- Tempo de cura completa: 24 horas;
- Velocidade da cura (colagem):
  - Madeira Balsa: < 10 segundos;
  - Borracha de nitrilo: 5 - 10 segundos;
  - EPDM: 5 - 10 segundos;
  - Neoprene: 5 - 10 segundos;
  - Aço (desengordurado): 20 a 50 segundos;
  - Policarbonato: 20 a 60 segundos;
  - Boa resistência a químicos.



Datos técnicos y ficha de seguridad disponible bajo pedido.

/ Technical information and safety data sheet available under request / Données techniques et fiche de sécurité disponible sur demande / Dados técnicos e ficha de segurança disponível sob pedido

dep.tecnico@pecol.pt

The P6 Glue is an adhesive set which consists of a high viscosity cyanoacrylate adhesive and activator.

The KIT has a high bonding strength and is suitable for use on vertical surfaces as it will not drip or slump.

It is particularly suitable to bonding difficult substrates which have a porous or uneven nature, since it increases bonding strength by preventing the adhesive to be absorbed by the surface.

### Characteristics

- Ester base, Ethyl-2-cyanoacrylate monomer;
- Appearance: Clear, colourless liquid;
- Density: 1,05 g/cm<sup>3</sup>;
- Shelf-life: 12 months, unopened;
- Flash Point > +81°C;
- Full Cure Time: 24 hours;
- Cure Speed (Bonding):
  - Balsa Wood: < 10 Seconds;
  - Nitrile Rubber: 7 Seconds;
  - EPDM: 7 Seconds;
  - Neoprene: 7 Seconds;
  - Steel (degreased): 25-40 Seconds;
  - Polycarbonate: 10-20 Seconds;
- Good chemical resistance.

La Colle P6 est un ensemble d'adhésion composé par une colle à base de cyanoacrylate de viscosité élevée et un activateur, qui forme un ensemble de haute efficacité pour le collage rapide de divers matériaux.

Le kit a une adhésion élevée et est adéquat pour une utilisation sur des surfaces verticales car il ne coule pas.

Il est particulièrement adapté au collage des supports difficiles, poreux ou inégaux, car il augmente la force de collage en empêchant la colle d'être absorbée par la surface.

### Caractéristiques

- Base ester, monomères ethyl-2-cyanoacrylate;
- Aspect: Liquide clair, incolore;
- Densité: 1,05 g / cm<sup>3</sup>;
- Validité: 12 mois, non ouvert;
- Flash point > +81 ° C;
- Plein de séchage total: 24 heures;
- Vitesse de séchage (Collage):
  - Bois de balsa: < 10 secondes;
  - Caoutchouc nitrile: 7 Seconds;
  - EPDM: 7 Seconds;
  - Néoprène: 7 Seconds;
  - Acier (dégraissé): 25-40 secondes;
  - Polycarbonate: 10-20 secondes;
- Bonne résistance aux produits chimiques.

El Adhesivo extra fuerte, con base de cianoacrilato de elevada viscosidad, juntamente con el Activador P6 forman un conjunto de alta eficacia para el pegado rápido de diversos materiales.

Este kit tiene un excelente poder de adherencia y puede ser aplicado en superficies verticales debido a que no escurre ni cae.

Está particularmente indicado para pegados complicados de substratos porosos o irregulares, ya que aumenta la resistencia de pegado, evitando que el adhesivo sea absorbido por el sustrato.

### Características

- Base: monómero de etil-2-cianoacrilato;
- Apariencia: Clara, transparente cuando líquida;
- Densidad: 1,05 g/cm<sup>3</sup>;
- Caducidad: 12 meses, cerrado en el embalaje;
- Punto de Inflamación: > +81°C;
- Tiempo de cura completa: 24 horas;
- Velocidad de la cura (pegado):
  - Madera Balsa: < 10 segundos;
  - Caucho de nitrilo: 7 segundos;
  - EPDM: 7 segundos;
  - Neopreno: 7 segundos;
  - Acero (desengrasado): 25 a 40 segundos;
  - Policarbonato: 10 a 20 segundos;
- Buena resistencia a químicos.



### CAPACIDADE CAPACITY / CAPACITÉ / CAPACIDAD

CÓDIGO  
CODE / CODE /  
CÓDIGO

ATIVADOR  
ACTIVATOR / ACTIVATEUR /  
ACTIVADOR

COLA P6  
GLUE / COLLE / ADHESIVO P 6

QUANTIDADE  
PACKAGE QTY / QT. PAQUETAGE / CANTIDAD

00100600000

200 ml

50 g

1 KIT (Ativador + Cola P 6) / 1 KIT (Activator + Glue) / 1 KIT (Activateur + Colle) / 1 KIT (Activador + Adhesivo P 6)





# Cola Cianoacrilato Pecol P1 Pen-System

Contact Cyanoacrylate Adhesive Pecol - P1 Pen-System / Colle Cyanoacrylate Pecol P1 Pen-System / Adhesivo Cianoacrilato Pecol P1 Pen-System

A cola de contacto cianoacrilato P1 Pecol é uma cola monocomponente de cura a frio, sem solventes. Tem uma polimerização rápida quando está em contacto com a humidade dos substratos e do ar e cura sob uma ligeira pressão.

A cola cianoacrilato cola em segundos quase todos os materiais entre si, como por exemplo, metais, plásticos, vidro, cerâmica, madeira, pele, borracha natural e sintética.

O produto está disponível num sistema inovador Pen System, de fácil utilização como uma caneta que cabe numa mão e garante: fácil aplicação, aplicação limpa e doseamento melhorado.

#### Características

- Baixa viscosidade 20-40 mPa.s
- Cura rápida;
- À base de éter etilo. Devido à dimensão das moléculas e ao espaçamento entre os pontos de colagem, é conseguida uma colagem de alta elasticidade. Por esta razão este tipo de cola é indicado para colagem de plásticos e borrachas;
- Não é sensível à exposição prolongada à humidade;
- Cor: transparente;
- Validade: 12 meses.



 **Dados técnicos e ficha de segurança disponível sob pedido.**  
/ Technical information and safety data sheet available under request / Données techniques et fiche de sécurité disponible sur demande / Datos técnicos y ficha de seguridad disponible bajo pedido  
dep.tecnico@pecol.pt



Pecol Contact Cyanoacrylate Adhesives P1 are cold curing, one-component adhesives, free of solvents. They quickly polymerise by reacting with moisture, both from the surfaces to be bonded and from the air, and cure under light pressure.

The cyanoacrylate adhesives will bond within seconds almost all materials to and among each other, such as: metals, plastics, glass, ceramics, wood, leather and natural and synthetic rubber.

The product is available in innovative special Pen System, very user friendly that lies in one hand like a pen and therefore guarantees: easy application, clean processing and improved dosing.

#### Characteristics

- Low viscosity, 20-40 mPa.s;
- Very fast-curing;
- Ethyl ester based types. Due to the size of the molecules and the resulting anchoring points positioned far from each other, a higher elasticity of the bond joint is achieved. These types are recommended for bonding plastics and rubber;
- Not sensitive to longer term humidity;
- Color: Transparent;
- Shelf life: 12 months.

La colle de contact cyanoacrylate P1 Pecol est une colle mono-composante d'endurissement à froid, sans solvants. Elle est de polymérisation rapide quand elle en contact avec l'humidité des supports et de l'air et elle durcit sous une légère pression.

La colle cyanoacrylate colle en secondes presque tous les matériaux entre eux, comme par exemple, les métaux, plastiques, verre, bois, peau, caoutchouc naturel et synthétique.

Le produit est disponible dans un système innovateur Pen System, de facile utilisation comme un stylo qui s'adapte à la main et garantit: une application facile, propre et un dosage amélioré.

#### Caractéristiques

- Basse viscosité 20-40 mPa.s
- Durcissement rapide;
- À base de éster éthylo. Du à la dimension des molécules et à la distance entre les points de colle, un collage de grande élasticité est réussi. Pour cette raison, ce type de colle est indiqué pour le collage de plastiques et caoutchoucs;
- N'est pas sensible à une exposition prolongé à l'humidité;
- Couleur: transparente;
- Validité: 12 mois.

El adhesivo de contacto cianoacrilato P1 Pecol es un adhesivo monocomponente de cura en frío, sin solventes. Tiene una polimerización rápida cuando está en contacto con la humedad de los sustratos y del aire y cura bajo una ligera presión.

El adhesivo cianoacrilato cura en segundos casi todos los materiales entre sí, como por ejemplo, metales, plásticos, vidrio, cerámica, madera, piel, goma natural y sintética.

El producto está disponible con un sistema innovador Pen System, de fácil utilización como un bolígrafo que cabe en una mano y garantiza: fácil aplicación, aplicación limpia y dosificación mejorada.

#### Características

- Baja viscosidad 20-40 mPa.s
- Cura rápida;
- A base de éster etilo. Debido a la dimensión de las moléculas y al espacio entre los puntos de pegado, se consigue un pegado de alta elasticidad. Por esta razón, este tipo de adhesivo está indicado para pegados de plásticos y gomas;
- No es sensible a la exposición prolongada a la humedad;
- Color: transparente;
- Validez: 12 meses.

CÓDIGO CODE / CODE / CÓDIGO	COR COLOR / COULEUR / COLOR	CAPACIDADE CAPACITY / CAPACITÉ / CAPACIDAD	EMBALAGEM QUANTITY / EMBALLAGE / EMBALAJE
001001000000	Transparente Opaco / Transparente mate / Transparente Opaque / Transp. Opaco	30 g	6





## VEDAÇÃO E COLAGEM

Sealing and Bonding / Étanche et Collage / Sellado y Pegado

# Cola Especial para PVC P5

PVC-U Special Adhesive P5 / Colle Spéciale pour PVC P5 / Adhesivo Especial para PVC P5



A Cola Especial para PVC P5 é um solvente sem THF (Tetrahidrofurano). Produto com configuração especial para colagem rápida de tubos de PVC e acessórios para tubos. A sua fórmula equilibrada permite uma extrema resistência na colagem, como se de uma só peça se tratasse. Transparente e não se altera com o passar do tempo. As juntas coladas ficam estanques.



**i** Dados técnicos e ficha de segurança disponível sob pedido.  
/ Technical information and safety data sheet available under request / Données techniques et fiche de sécurité disponible sur demande / Datos técnicos y ficha de seguridad disponible bajo pedido  
dep.tecnico@pecol.pt

Pecol PVC-U special adhesive P5 is a solvent without THF (tetrahydrofuran). Special quick setting glue for PVC pipes and pipe fittings. Balanced formula permits extremely resistant gluing equal to a single casting of the piece. Transparent does not alter over time. The bonded joints are waterproof.

La Colle Spéciale pour PVC P5 est un solvant sans THF (Tétrahydrofurane). Produit avec une configuration spéciale pour le collage rapide de tube de PVC et accessoires pour tubes. Sa formule équilibrée permet une résistance extrême dans le collage, comme si elles ne forment qu'une seule pièce. Transparente et ne s'altère pas au long du temps. Les joints collés deviennent étanches.

El Adhesivo Especial para PVC P5 es un solvente sin THF (Tetrahidrofurano). Producto con configuración especial para pegado rápido de tubos de PVC y accesorios para tubos. Su fórmula equilibrada permite una extrema resistencia en el pegado, como si de una pieza sola se tratase. Transparente y no se altera con el paso del tiempo. Las juntas pegadas quedan estancas.



**CÓDIGO**  
CODE / CODE / CÓDIGO

001005000000

**CAPACIDADE**  
CAPACITY / CAPACITÉ / CAPACIDAD

250 ml

**EMBALAGEM**  
QUANTITY / EMBALLAGE / EMBALAJE

12

# Produto de Limpeza para PVC P55

PVC Cleaner P 55 / Produit de Nettoyage pour PVC P 55 / Producto de Limpieza para PVC P55



O produto de limpeza de PVC P 55 é um produto composto por Acetona e Butanona adequado para limpeza de tubos e acessórios de PVC e ABS. Densidade de 0,8 g/ml a +20°C. Embalagem: Lata de Estanto de 500 ml em caixas de cartão com 6 unidades.

**i** Dados técnicos e ficha de segurança disponível sob pedido.  
/ Technical information and safety data sheet available under request / Données techniques et fiche de sécurité disponible sur demande / Datos técnicos y ficha de seguridad disponible bajo pedido  
dep.tecnico@pecol.pt

Pecol PVC Cleaner is a cleaning agent based on acetone and methyl ethyl ketone suitable for pipes and fitting made of PVC-U, PVC-C and ABS. This is not suitable for polyolefin weld joints. Density of 0,8 g/ml at +20°C. Packaging: 500ml tin 6 units per carton.

Le Produit de Nettoyage pour PVC P 55 est un produit composé par de l'Acétone et de la Butanone, adéquat pour le nettoyage de tubes et accessoires de PVC et ABS. Densité de 0,8 g/ml à +20°C. Paquetage: Bidon en Étain de 500 ml en boîtes en carton de 6 unités.

El producto de limpieza de PVC P 55 es un producto compuesto por Acetona y Butanona adecuado para limpieza de tubos y accesorios de PVC y ABS. Densidad de 0,8 g/ml a +20°C. Embalaje: Lata de Estanto de 500 ml en cajas de cartón con 6 unidades.



**CÓDIGO**  
CODE / CODE / CÓDIGO

000921000000

**CAPACIDADE**  
CAPACITY / CAPACITÉ / CAPACIDAD

500 ml

**EMBALAGEM**  
QUANTITY / EMBALLAGE / EMBALAJE

6





# Cola Poliuretano D4

D4 PUR Fast Glue / Colle Polyuréthane D4 / Adhesivo Poliuretano D4

A Cola de Poliuretano D4 foi especialmente concebida para colagens rápidas em todo o tipo de madeiras, especialmente em exteriores. Este produto está inserido no grupo D4 e está de acordo com a norma DIN/EN 204.

#### Características

Cor: Amarelada  
Densidade: Ca 1,10 g/cm<sup>3</sup>  
Viscosidade: Ca 5000 mPa.s (Brookfield RVT sp4, 20 rpm)  
Tempo de abertura: Cerca de 7 minutos  
Temperatura de armazenamento: > +10°C e <+25°C



**i** Dados técnicos e ficha de segurança disponível sob pedido.  
/ Technical information and safety data sheet available under request / Données techniques et fiche de sécurité disponible sur demande / Datos técnicos y ficha de seguridad disponible bajo pedido  
dep.tecnico@pecol.pt



**D4**  
EN 204 D4

This glue is especially formulated for fast gluing of all wood types, especially outdoors corresponds to loading group D4, pursuant to DIN/EN204.

#### Characteristics

Colour: Yellowish  
Density: Ca 1,10 g/cm<sup>3</sup>  
Viscosity: Ca 5000 mPa.s (Brookfield RVT sp4, 20 rpm)  
Open time: About 7 minutes  
Storage temperature: > +10°C; < +25°C

La Colle de polyuréthane D4 a été spécialement conçue pour collages rapides sur tous types de bois, spécialement les extérieurs. Ce produit s'insère dans le groupe D4 et respecte la norme DIN/EN 204.

#### Caractéristiques

Couleur: Jaune  
Densité: Ca 1,10 g/cm<sup>3</sup>  
Viscosité: Ca 5000 mPa.s (Brookfield RVT sp4, 20 rpm)  
Temps d'ouverture: Environ 7 minutes  
Température de stockage: > +10°C et <+25°C

El Adhesivo de Poliuretano D4 fue especialmente concebido para pegados rápidos en todo tipo de maderas, especialmente en exteriores. Este producto está integrado en el grupo D4 y de acuerdo con la norma DIN/ EN 204.

#### Características

Color: Amarillento  
Densidad: Ca 1,10 g/cm<sup>3</sup>  
Viscosidad: Ca 5000 mPa.s (Brookfield RVT sp4, 20 rpm)  
Tiempo de apertura: Cerca de 7 minutos  
Temperatura de almacenamiento: > +10°C y <+25°C

CÓDIGO CODE / CODE / CÓDIGO	COR COLOR / COULEUR / COLOR	CAPACIDADE CAPACITY / CAPACITÉ / CAPACIDAD	EMBALAGEM QUANTITY / EMBALLAGE / EMBALAJE
001007000001	Amarelado / Yellowish / jaune / Amarillento	750 gr	12





# VEDAÇÃO E COLAGEM

Sealing and Bonding / Étanche et Collage / Sellado y Pegado

## Cola para Madeira D3/D4

Cold Wood Adhesive D3/D4 Fast / Colle pour Bois D3/D4 / Cola para Madera D3/D4

D3

DIN EN 204

D4\*

DIN EN 204



A Cola para madeira D3/D4 foi especialmente concebida para todo o tipo de colagens em todo o tipo de madeiras em que seja necessária uma colagem rápida, forte e com excelentes níveis de resistência à água, estando de acordo com o grupo D3 de colas.

Após a adição de 5% de endurecedor D4 (cód. 005904100000), o produto fica de acordo com o grupo D4 de colas (EN 204).

### Características

Cor: Branca (transparente quando está seca)

Excelente resistência à água, de acordo com o grupo de colas D3 e D4 (após adição de 5% do endurecedor).



Dados técnicos e ficha de segurança disponível sob pedido.

/ Technical information and safety data sheet available under request / Données techniques et fiche de sécurité disponible sur demande / Datos técnicos y ficha de seguridad disponible bajo pedido  
dep.tecnico@pecol.pt

\* Após a adição de 5% de endurecedor D4 / After adding 5% of hardener D4 / Après l'addition de 5% de durcisseur D4 / Tras la adición de 5% de endurecedor D4

This glue is especially formulated for all wood bonding when a fast set, high bond strength and excellent water resistance are required complies with loading group D3.

After adding 5% of hardener D4 (ref. 005904100000) complies with loading group D4 (EN 204).

### Characteristics

Colour: White (clear when dry)

Excellent water resistance complies with loading group D3 and D4 after adding 5% hardener D4.

La Colle pour Bois D3/D4a été spécialement conçue pour tous types de collages sur tous types de bois dans le cas où un collage rapide, fort et avec d'excellents niveaux de résistance à l'eau est nécessaire, étant en accord avec le groupe D3 de colles.

Après l'addition de 5% de durcisseur D4 (cód. 005904100000), le produit entre en accord avec le groupe D4 de colles (EN 204).

### Caractéristiques

Couleur: Blanc (transparente quand elle est sèche)

Excellente résistance à l'eau, en accord avec le groupe de colles D3 et D4 (après addition de 5% de durcisseur).

La Cola para madeira D3/D4 fue especialmente formulada para todo tipo de pegados en todo tipo de maderas en que sea necesario un pegado rápido, fuerte y con excelentes niveles de resistencia al agua, estando de acuerdo con el grupo D3 de colas.

Tras la adición de 5% de endurecedor D4 (cód. 005904100000), el producto queda de acuerdo con el grupo D4 de colas (EN 204).

### Características

Color: Blanco (transparente cuando está seca)

Excelente resistencia al agua, de acuerdo con el grupo de colas D3 y D4 (tras adición de 5% del endurecedor).



CÓDIGO  
CODE / CODE /  
CÓDIGO

005904000000

### COR

COLOR / COULEUR / COLOR

Branco / White / Blanc / Blanco

### CAPACIDADE

CAPACITY / CAPACITÉ  
/ CAPACIDAD

5 Kg

### EMBALAGEM

QUANTITY / EMBALLAGE /  
EMBALAJE

1



CÓDIGO  
CODE / CODE /  
CÓDIGO

005904100000

### CAPACIDADE

CAPACITY / CAPACITÉ  
/ CAPACIDAD

500 g

### EMBALAGEM

QUANTITY / EMBALLAGE /  
EMBALAJE

1



# Cola Rápida para Madeira D2

Cold Wood Adhesive D2 Fast / Colle pour Bois D2 Rapide / Adhesivo Rápido para Madera D2

A Cola para Madeira D2 foi especialmente concebida e formulada para todo o tipo de colagens em madeiras que necessitem de uma rápida e forte cura, de acordo com o grupo de cargas D2 (DIN EN 204).

#### Características

Cor: Branca (transparente quando está seca)  
Elevada resistência à água, de acordo com o grupo de cargas D2 (DIN EN 204).



**i** **Datos técnicos y ficha de seguridad disponible bajo pedido.**  
/ Technical information and safety data sheet available under request / Données techniques et fiche de sécurité disponible sur demande / Dados técnicos e ficha de segurança disponível sob pedido  
dep.tecnico@pecol.pt



**D2**  
DIN EN 204

This glue is especially formulated for all wood bonding when a fast set and high bond strength are required complies with loading group D2 (DIN EN 204).

#### Characteristics

Colour: White (clear when dry)  
Good water resistance complies with loading group D2.

La Colle pour Bois D2 a été spécialement conçue pour tous types de collages sur tous types de bois dans le cas où un collage rapide et un grand pouvoir d'adhésion sont requis, en conformité avec le groupe D2 (DIN EN 204).

#### Caractéristiques

Couleur: Blanc (après séchage)  
Bonne résistance à l'eau, en conformité avec les spécifications du groupe D2.

El Adhesivo para Madera D2 fue especialmente concebido y formulado para todo tipo de pegados en maderas que necesiten una rápida y fuerte cura, de acuerdo con el grupo de cargas D2 (DIN EN 204)

#### Características

Color: Blanco (transparente cuando está seco)  
Elevada resistencia al agua, de acuerdo con el grupo de cargas D2 (DIN EN 204).

CÓDIGO CODE / CODE / CÓDIGO	COR COLOR / COULEUR / COLOR	CAPACIDADE CAPACITY / CAPACITÉ / CAPACIDAD	EMBALAGEM QUANTITY / EMBALLAGE / EMBALAJE
005905000000	Branco / White / Blanc / Blanco	25 Kg	1



# Cola de Contacto Tixotrópica

Thixotropic Contact Adhesive Gel / Colle de Contact Thixotropique / Adhesivo de Contacto Tixotrópico

Adesivo de Contacto com base em gel de policloropreno, resinas sintéticas e solventes.

#### Características

Tipo de produto: policloropreno em gel  
Cor: Amarela  
Teor de sólidos: 27%  
Densidade: 0,85 g/cm<sup>3</sup>  
Viscosidade: Tixotrópica  
Tempo aberto: Máx. de 40 minutos (à temperatura ambiente)  
Validade: 12 meses (devidamente armazenada).



**i** **Datos técnicos y ficha de seguridad disponible bajo pedido.**  
/ Technical information and safety data sheet available under request / Données techniques et fiche de sécurité disponible sur demande / Dados técnicos e ficha de segurança disponível sob pedido  
dep.tecnico@pecol.pt



This Thixotropic Contact Adhesive Gel is based on polychloroprene rubber, synthetic resins and solvents.

#### Characteristics

Basic Material: Polychloroprene rubber  
Colour: Yellowish  
Solid content: 27%  
Specific gravity: 0,85 g/cm<sup>3</sup>  
Viscosity: Thixotropic  
Open time: Max. 40 minutes (room temperature)  
Shelf life: 12 months

La Colle de Contact Thixotropique est à base de caoutchouc de polychloroprène, de résines synthétiques et de solvants.

#### Caractéristiques

Base: Caoutchouc de polychloroprène  
Couleur: Jaune  
Teneur en solide: 27%  
Densité: 0,85 g/cm<sup>3</sup>  
Viscosité: Thixotropique  
Temps ouvert: 40 minutes (température ambiante)  
Validité: 12 mois

Adhesivo de Contacto com base em gel de policloropreno, resinas sintéticas e solventes.

#### Características

Tipo de produto: policloropreno em gel  
Color: Amarillo  
Grado de sólidos: 27%  
Densidad: 0,85 g/cm<sup>3</sup>  
Viscosidad: Tixotrópico  
Tiempo abierto: Máx. de 40 minutos (a temperatura ambiente)  
Caducidad: 12 meses (debidamente almacenado)

CÓDIGO CODE / CODE / CÓDIGO	COR COLOR / COULEUR / COLOR	CAPACIDADE CAPACITY / CAPACITÉ / CAPACIDAD	EMBALAGEM QUANTITY / EMBALLAGE / EMBALAJE
005902000000	Amarela / Yellow / Jaune / Amarilla	750 ml	12





# VEDAÇÃO E COLAGEM

Sealing and Bonding / Étanche et Collage / Sellado y Pegado

## Ceras para Madeira

Soft Wax in Sticks / Cires pour Bois / Ceras para Madera



Caixa de 20 uni. - Ceras para Madeira / Soft Wax Stick - Box - 20 Uni. / Boîte de 20 uni. - Cires pour Bois / Caja de 20 uni. - Ceras para Madera

As Ceras para Madeira em stick foram desenvolvidas para reparar superfícies em melamina ou de madeira que estejam danificadas com pequenos riscos/fissuras e que não estejam sujeitas a utilizações exageradas.

### Características

- Geral: Ceras microcristalinas para reparações de madeiras;
- Bases de Solvente: Não;
- Secagem rápida;
- Lacável: A superfície pode ser lacada, mas aconselha-se um teste prévio.

### Cores disponíveis / Colors available / Couleurs disponibles / Colores disponibles

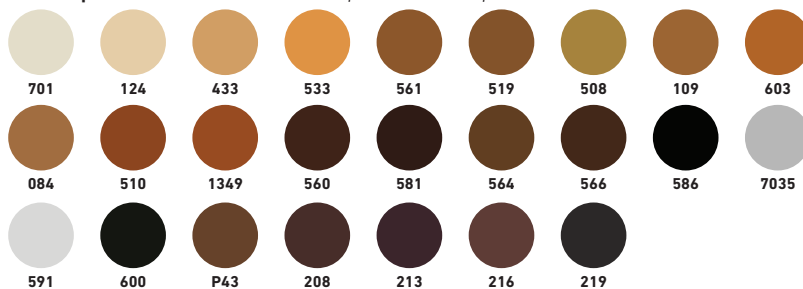

Dados técnicos e ficha de segurança disponível sob pedido.

/ Technical information and safety data sheet available under request / Données techniques et fiche de sécurité disponible sur demande / Datos técnicos y ficha de seguridad disponible bajo pedido

dep.technico@pecol.pt

Soft Wax in Stick for a filling repair of slight damages at wooden and melamine surfaces, which are not subjects to severe use.

### Characteristics

- General: Micro-crystalline waxes as filling-product;
- Bases of solvent: Not;
- Light fast: Good;
- Lacquable: Can be coated but the coatings have to be tested before application.

Les Cires pour Bois en stick ont été développées pour réparer les surfaces en mélamine ou en bois qui sont endommagées avec de petits risques/fissures et qui ne sont pas soumises à des utilisations exagérées.

### Caractéristiques

- Générale: Cires microcristallines pour réparations de bois;
- Bases de Solvant: Non;
- Séchage rapide;
- Laquage: La surface peut être laquée, mais un test préalable est conseillé.

Las Ceras para Madera en stick han sido desarrolladas para reparar superficies en melamina o de madera que estén dañadas con pequeñas rayas/fisuras y que no estén sujetas a utilizaciones exageradas.

### Características

- General: Ceras microcristalinas para reparaciones de maderas;
- Bases de Solvente: No;
- Secado rápido;
- Lacable: La superficie puede ser lacada, aunque se aconseja una prueba previa.



Caixa de 20 uni. - Ceras para Madeira / Soft Wax Stick - Box - 20 Uni. / Boîte de 20 uni. - Cires pour Bois / Caja de 20 uni. - Ceras para Madera

CÓDIGO	COR	EMBALAGEM
CODE / CODE / CÓDIGO	COLOR / COULEUR / COLOR	QUANTITY / EMBALLAGE / EMBALAJE
005906000001	S2	20



Saco de 4 uni. - Ceras para Madeira / Soft Wax Stick - Plastic bag - 4 Uni. / Sachet de 4 uni. - Cires pour Bois / Bolsa de 4 uni. - Ceras para Madera

CÓDIGO	COR	EMBALAGEM	CÓDIGO	COR	EMBALAGEM
CODE / CODE / CÓDIGO	COLOR / COULEUR / COLOR	QUANTITY / EMBALLAGE / EMBALAJE	CODE / CODE / CÓDIGO	COLOR / COULEUR / COLOR	QUANTITY / EMBALLAGE / EMBALAJE
005906043000	P43	4	005906533000	533	4
005906084000	084	4	005906560000	560	4
005906109000	109	4	005906561000	561	4
005906124000	124	4	005906564000	564	4
005906134900	1349	4	005906566000	566	4
005906208000	208	4	005906581000	581	4
005906213000	213	4	005906586000	586	4
005906216000	216	4	005906591000	591	4
005906219000	219	4	005906600000	600	4
005906433000	433	4	005906603000	603	4
005906508000	508	4	005906701000	701	4
005906510000	510	4	005906703500	7035	4
005906519000	519	4			



# Barra de Cola Termofusível

Hot Melt Glue Stick / Bâtonnet de Colle Thermofusible / Barra de Cola Termofusible

As barras de cola termofusível são matérias termoplásticas que derretem e solidificam durante a aplicação. À base de EVA (etileno acetato de vinil) e de resina, a cola pode ser convenientemente aplicada usando uma pistola de aplicação de cola termofusível. A cola adere a quente e solidifica em poucos segundos até um minuto, dependendo da humidade e temperatura.

Os adesivos termofusíveis oferecem diversas vantagens comparativamente aos adesivos à base de solvente:

- Redução ou eliminação de compostos orgânicos ou voláteis (COV);
- Tempo de cura é eliminado;
- Oferecem um tempo de vida mais longo e podem ser eliminados sem cuidados específicos;
- A cola não perde volume durante a solidificação (as colas à base de solventes perdem até 50-70% da espessura da camada durante a cura).

Disponível em barras de 11 mm de diâmetro e 30 cm de comprimento em branco, preto e transparente (sendo perfeito para aplicações elétricas).

Disponível em saco de 1 kg.



**i** **Datos técnicos y ficha de seguridad disponible bajo pedido.**  
/ Technical information and safety data sheet available under request / Données techniques et fiche de sécurité disponible sur demande / Dados técnicos e ficha de segurança disponível sob pedido  
dep.tecnico@pecol.pt



The general purpose hot melt glue sticks are thermoplastic materials that melt and resolidify upon cooling. Based on EVA (Ethylene-vinyl acetate) and resin, the hot melt sticks can be conveniently dispensed using hot melt glue gun applicators. The glue is tacky when hot, and solidifies in a few seconds to one minute depending the moisture and temperature.  
The hot melt adhesives provide several advantages comparing with solvent-based adhesives:

- Volatile organic compounds are reduced or eliminated;
- The drying or curing step is eliminated;
- Hot melt adhesives have long shelf life and usually can be disposed without special precautions;
- Hot melt don't lose thickness during solidifying (solvent-based adhesives may lose up to 50-70% of layer thickness during drying).

Available in sticks of 11 mm diameter and 30 cm length in white, black and transparent (perfect one for the electrical application).  
Available in 1 kg poly bags.

Les bâtonnets de colle thermofusibles sont des matériaux thermoplastiques qui fondent et solidifient lors de l'application. À base d'EVA (éthylène-acétate de vinyle) et de résine, les bâtonnets de colle peuvent être convenablement appliqués à l'aide du pistolet à colle. La colle adhère à chaud et se solidifie en quelques secondes jusqu'à une minute, en fonction de l'humidité et la température. Les adhésifs thermofusibles offrent plusieurs avantages en comparaison avec les adhésifs à base de solvants:

- Les composés organiques ou volatils sont réduits ou éliminés;
- Le temps de séchage est éliminé;
- Les adhésifs thermofusibles ont une durée de vie longue et peuvent généralement être éliminés sans précautions particulières;
- La colle thermofusible ne perd pas de volume pendant la solidification (les colles à base de solvants peuvent perdre jusqu'à 50-70% de l'épaisseur de la couche pendant le séchage).

Disponibles en bâtonnets de 11 mm de diamètre et de 30 cm de longueur en blanc, noir et transparent (parfait pour l'application électrique).  
Disponibles en sachet de 1 kg.

Las barras de cola termofusible son materias termoplásticas que derriten y solidifican durante la aplicación. A base de EVA (etileno acetato de vinilo) y de resina, la cola puede ser convenientemente aplicada usando una pistola de aplicación de cola termofusible. La cola adhiere en caliente y solidifica en pocos segundos hasta un minuto, dependiendo de la humedad y temperatura.  
Los adhesivos termofusibles ofrecen diversas ventajas en comparación a los adhesivos a base de solvente:

- Reducción o eliminación de compuestos orgánicos o volátiles (COV);
- Se elimina el tiempo de cura;
- Ofrecen un tiempo de vida más largo y pueden ser eliminados sin cuidados específicos;
- La cola no pierde volumen durante la solidificación (las colas a base de solventes pierden hasta 50-70% del espesor de la capa durante la cura).

Disponibles en barras de 11 mm de diámetro y 30 cm de largo en blanco, negro y transparente (siendo perfecto para aplicaciones eléctricas).  
Disponibles en bolsa de 1 kg.

CÓDIGO CODE / CODE / CÓDIGO	COR COLOR / COULEUR / COLOR	CPS	CAPACIDADE CAPACITY / CAPACITÉ / CAPACIDAD	EMBALAGEM QUANTITY / EMBALLAGE / EMBALAJE	QTD. PALETE PALET / QT. PALETTE / CANT. PALÉ
001008000001	Transparente / Transparent / Transparent / Transparente	19000	1 kg	1	200 kg
001008000002	Branco / White / Blanc / Blanco	13000	1 kg	1	200 kg
001008000003	Preto / Black / Noir / Negro	13000	1 kg	1	200 kg

## Pistola para Cola Termofusível Special

Hot Melt Glue Gun Special / Pistolet à Colle Thermofusible Special / Pistola de Cola Termofusible Special

CÓDIGO CODE / CODE / CÓDIGO	POTÊNCIA POWER / CAPACITÉ / CAPACIDADE	EMBALAGEM QUANTITY / EMBALLAGE / EMBALAJE
001008000100	220w	1



**Ideal para uso profissional | Ideal para utilização em trabalhos contínuos.**  
For all professional usage in carpeting and woodworking industry. Useful for non-stop working.  
Idéal pour tout usage professionnel. Utilisation pour un travail en continu.  
Ideal para uso profesional. Ideal para utilización en trabajos continuos.





# VEDAÇÃO E COLAGEM

Sealing and Bonding / Étanche et Collage / Sellado y Pegado

## Cola para Orladora HM-800

HM-800 Edge Banding Adhesive Glue / Colle pour Plaqueuse de Chant HM-800 / Cola para Canteadora HM-800



Cola termofusível universal, indicada para máquinas de alta velocidade à base de um copolímero de EVA, com ótimas propriedades de adesão e colagem.

### Ideal para colar

- Madeira;
- PVC;
- Melamina;
- Outro tipo de materiais



Dados técnicos e ficha de segurança disponível sob pedido.

/ Technical information and safety data sheet available under request / Données techniques et fiche de sécurité disponible sur demande / Datos técnicos y ficha de seguridad disponible bajo pedido dep.technico@pecol.pt

VISCOSIDADE (mPa.s)	
VISCOSITY / VISCOSITÉ / VISCOSIDAD	
190°C	90.000 - 120.000
200°C	70.000 - 90.000
210°C	50.000 - 70.000



Universal thermofusible glue, suitable for high speed machines based on an EVA copolymer, with excellent adhesion and bonding properties.

### Ideal for gluing

- Wood;
- PVC;
- Melamine;
- Other kind of materials

Colle thermofusible universelle, adaptée aux machines à grande vitesse à base d'un copolymère d'EVA, avec d'excellentes propriétés d'adhésion et de collage.

### Idéal pour coller

- Bois;
- PVC;
- Mélangine;
- Autres matériaux

Cola termofusible universal, indicada para máquinas de alta velocidad a base de un copolímero de EVA, con óptimas propiedades de adhesión y encolado.

### Idéal para pegar

- Madera;
- PVC;
- Melamina;
- Otro tipo de materiales



**CÓDIGO**  
CODE / CODE / CÓDIGO  
001008200000

**COLOR**  
COLOR / COULEUR / COR  
Amarillento / Yellowish / jaune / Amarelado

**CAPACIDAD**  
CAPACITY / CAPACITÉ / CAPACIDADE  
25 kg

**EMBALAJE**  
QUANTITY / EMBALLAGE / EMBALAGEM  
1

## Cola para Orladora HM-810

HM-810 Edge Banding Adhesive Glue / Colle pour Plaqueuse de Chant HM-810 / Cola para Canteadora HM-810



Cola termofusível, à base de um copolímero de EVA, com ótimas propriedades adesivas e indicada para a generalidade das máquinas de orlar.

### Idéal para colar

- Madeira;
- PVC;
- Melamina;
- Ripas maciças\*;
- Papel resinado\*.

\* Deve-se testar a adesão sobre os materiais antes da aplicação industrial.



Dados técnicos e ficha de segurança disponível sob pedido.

/ Technical information and safety data sheet available under request / Données techniques et fiche de sécurité disponible sur demande / Datos técnicos y ficha de seguridad disponible bajo pedido dep.technico@pecol.pt

VISCOSIDADE (mPa.s)	
VISCOSITY / VISCOSITÉ / VISCOSIDAD	
190°C	75.000 - 100.000
200°C	50.000 - 70.000
210°C	40.000 - 60.000



A thermofusible glue based on an EVA copolymer with excellent adhesive properties and suitable for all milling machines.

### Idéal for gluing

- Wood;
  - PVC;
  - Melamine;
  - Solid strips\*;
  - Resin paper\*.
- \* Adherence to materials must be tested prior to industrial application.

Colle thermofusible à base de copolymère d'EVA avec d'excellentes propriétés adhésives et adaptée à toutes les plaqueuses de chant.

### Idéal pour coller

- Bois;
  - PVC;
  - Mélangine;
  - Lattes solides\*;
  - Papier résine\*.
- \* L'adhésion aux matériaux doit être testée avant l'application industrielle.

Cola termofusible, a base de un copolímero de EVA, con óptimas propiedades adhesivas y indicada para la generalidad de las máquinas aplicadoras de cantos.

### Idéal para pegar

- Madera;
  - PVC;
  - Melamina;
  - Ripas macizas\*;
  - Papel resinado\*.
- \* Se debe probar la adhesión sobre los materiales antes de la aplicación industrial.



**CÓDIGO**  
CODE / CODE / CÓDIGO  
001008200001

**COLOR**  
COLOR / COULEUR / COR  
Amarillento / Yellowish / jaune / Amarelado

**CAPACIDAD**  
CAPACITY / CAPACITÉ / CAPACIDADE  
25 kg

**EMBALAJE**  
QUANTITY / EMBALLAGE / EMBALAGEM  
1



# Cola para Embalagem HME-510

HME-510 Packaging Glue / Colle d'Emballage HME-510 / Cola para Embalaje HME-510

A Cola para Embalagem HME-510 é um adesivo termofusível rápido (à base de polímero EVA) com baixa viscosidade. Esta cola foi especialmente concebida para a colagem de embalagens de cartão em máquinas de alta velocidade e com ponteiros de baixo calibre.

#### Idéal para colar

- Máquinas de montagem de caixas;
- Indicado para o setor:
  - Alimentar;
  - Azeite e Vinhos;
  - Bebidas;
  - Hortofrutícola (frutas e legumes);
  - Cerâmica;
  - Eletrónica;
  - Mobiliário;
  - Embalagens de cartão;

VISCOSIDADE (mPa.s)	
VISCOSITY / VISCOSITÉ / VISCOSIDAD	
140°C	1.600 - 2.400
160°C	800 - 1.200
180°C	500-800



Dados técnicos e ficha de segurança disponível sob pedido.

/ Technical information and safety data sheet available under request / Données techniques et fiche de sécurité disponible sur demande / Datos técnicos y ficha de seguridad disponible bajo pedido

dep.tecnico@pecol.pt

HME-510 Packaging Glue is a fast thermofusibile adhesive (EVA polymer-based) with low viscosity. This glue has been specially designed for the gluing of cardboard packs on high speed machines and with low caliber tips.

#### Idéal for gluing

- Box assembly machines;
- Indicated for the sector of:
  - Food;
  - Olive oil and Wines;
  - Beverages;
  - Horticultural (fruits and vegetables);
  - Ceramics;
  - Electronics;
  - Furniture;
  - Cardboard packaging;

La colle d'emballage HME-510 est un adhésif thermofusibile rapide (à base de polymère EVA) à faible viscosité. Cette colle a été spécialement conçue pour le collage d'emballages en carton dans des machines à grande vitesse et avec des pointes de faible calibre.

#### Idéal pour coller

- Machines d'assemblage de boîtes;
- Indiqué pour les secteurs:
  - Alimentaire;
  - Huile d'olive et Vins;
  - Boissons;
  - Fruits et légumes;
  - Céramique;
  - Électronique;
  - Meubles;
  - Emballage en carton;

La Cola para Embalaje HME-510 es un adhesivo termofusibile rápido (a base de polímero EVA) con baja viscosidad. Esta cola ha sido especialmente diseñada para el encolado de envases de cartón en máquinas de alta velocidad y con punteras de bajo calibre.

#### Idéal para pegar

- Máquinas de montaje de cajas;
- Indicado para el sector de:
  - Alimentación;
  - Aceite de oliva y vino;
  - Bebidas;
  - Hortofrutícola (frutas y verduras);
  - Cerámica;
  - Electrónica;
  - Mobiliario;
  - Embalajes de cartón;

CÓDIGO	COLOR	CAPACIDAD	EMBALAJE
CODE / CODE / CÓDIGO	COLOR / COULEUR / COR	CAPACITY / CAPACITÉ / CAPACIDADE	QUANTITY / EMBALLAGE / EMBALAGEM
001008100000	Amarillento / Yellowish / jaune / Amarelado	20 kg	1





# VEDAÇÃO E COLAGEM

Sealing and Bonding / Étanche et Collage / Sellado y Pegado

## PW10 Exterior Deck

PW10 Exterior Deck / PW10 Extérieur Deck et Satiné / PW10 Exterior (Deck y Satinado)



Impregnante monocomponente de base aquosa para decks de madeira. Este produto confere à madeira uma proteção contra raios UV, assim como proteção fungicida, bactericida e inseticida. Tem baixos níveis de viscosidade e teor de sólidos, de forma a garantir um excelente poder de penetração na madeira. O poro fica aberto, permitindo que a madeira respire e facilitando a manutenção.

**Cores disponíveis / Colors available / Couleurs disponibles / Colores disponibles**



**Ipê**  
/ Ipe / Ipé / Ipé



**Teka**  
/ Teka / Teck / Teka



**Pinho**  
/ Pine / Pin / Pino



**Incolor**  
/ Colourless / Incolore / Incoloro



**Datos técnicos y ficha de seguridad disponible bajo pedido.**

*/ Technical information and safety data sheet available under request / Données techniques et fiche de sécurité disponible sur demande / Dados técnicos y ficha de seguridad disponible sob pedido*  
[dep.technico@pecol.pt](mailto:dep.technico@pecol.pt)



One component water-borne impregnations for outdoor wooden floors (pure deck). They give wood protection against outdoor agents (UV light, fungi...). They have a low viscosity and solids content in order to achieve a high penetration power. Open pore finishing wish offers an easy maintenance.

Impregnant mono-composant de base aqueuse pour decks en bois. Ce confère au bois une protection contre les rayons UV, ainsi que fongicide, bactéricide et insecticide. Les niveaux de viscosité et teneur en solides sont bas, garantissant un excellent pouvoir de pénétration dans le bois. Le pore reste ouvert, proportionnant une facile manutention.

Impregnante monocomponente de base acuosa para decks de madera. Este producto confiere a la madera una protección contra los rayos UV, así como protección fungicida, bactericida e insecticida. Tiene bajos niveles de viscosidad y grado de sólidos, de forma que se garantiza un excelente poder de penetración en la madera. El poro queda abierto, permitiendo que la madera respire y facilitando el mantenimiento.



CÓDIGO CODE / CODE / CÓDIGO	COR COLOR / COULEUR / COLOR	CAPACIDADE CAPACITY / CAPACITÉ / CAPACIDAD	EMBALAGEM QUANTITY / EMBALLAGE / EMBALAJE
00580100001	Ipê / Ipe / Ipé / Ipé	5 L	1
00580100003	Pinho / Pine / Pin / Pino	5 L	1
00580100004	Teka / Teka / Teck / Teka	5 L	1
00580100005	Incolor / Colourless / Incolore / Incoloro	5 L	1

## PW10 Exterior Acetinado

PW10 Exterior Satiny / PW10 Extérieur Satiné / PW10 Exterior Satinado



Impregnante monocomponente de base aquosa para todo o tipo de madeiras de exterior, que confere um acabamento fantástico e protege todo o tipo de madeiras.

O PW10 Acetinado aumenta o brilho natural da madeira, dando mais cor e prevenindo do envelhecimento.

**Cores disponíveis / Colors available / Couleurs disponibles / Colores disponibles**



**Carvalho Francês**  
/ French Oak / Chêne / Roble Francés



**Teka**  
/ Teka / Teck / Teka



**Nogueira**  
/ Walnut / Noyer / Nogal



**Incolor**  
/ Colourless / Incolore / Incoloro



**Nogueira Escuro**  
/ Dark Walnut / Noyer foncé / Nogal oscuro



**Caoba**  
/ Caoba / Acajou / Caoba

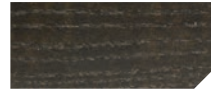

**Ébano**  
/ Ebony / Ébène / Ébano



**Datos técnicos y ficha de seguridad disponible bajo pedido.**

*/ Technical information and safety data sheet available under request / Données techniques et fiche de sécurité disponible sur demande / Dados técnicos y ficha de seguridad disponible sob pedido*  
[dep.technico@pecol.pt](mailto:dep.technico@pecol.pt)

Range of water-borne wood finishes protectors wish are developed in order to protect and to embellish any kind of wood, both indoor and outdoor. The PW10 Satiny increase the natural beauty of wood, adding some more colour and preventing greying.

Impregnant mono-composant de base aqueuse pour tous types de bois d'extérieur, embellit et protège tous type de bois. PW 10 Satiné améliore l'aspect naturel du bois, lui donne plus de couleur et prévient son vieillissement.

Impregnante monocomponente de base acuosa para todo tipo de maderas de exterior, que confiere un acabado fantástico y protege todo tipo de maderas. El PW10 Satinado aumenta el brillo natural de la madera, dando más color y previniendo del envejecimiento.



CÓDIGO CODE / CODE / CÓDIGO	COR COLOR / COULEUR / COLOR	CAPACIDADE CAPACITY / CAPACITÉ / CAPACIDAD	EMBALAGEM QUANTITY / EMBALLAGE / EMBALAJE
005801000100	Incolor / Colourless / Incolore / Incoloro	5 L	1
005801000101	Carvalho Francês / French Oak / Chêne / Roble Francés	5 L	1
005801000102	Teka / Teka / Teck / Teka	5 L	1
005801000103	Nogueira / Walnut / Noyer / Nogal	5 L	1
005801000104	Nogueira Escuro / Dark Walnut / Noyer foncé / Nogal oscuro	5 L	1
005801000105	Ébano / Ebony / Ébène / Ébano	5 L	1
005801000106	Caoba / Caoba / Acajou / Caoba	5 L	1





## PW10 Renovador

PW10 Renovator / PW10 Rénovateur / PW10 Renovador



Produto de base aquosa e praticamente inodoro que limpa e protege madeiras manchadas e envelhecidas com o decorrer do tempo

**Características**

- Limpa e revitaliza todo o tipo de madeiras;
- Recupera o tom natural da madeira;
- Base Aquosa.

**Dados técnicos e ficha de segurança disponível sob pedido.**  
/ Technical information and safety data sheet available under request / Données techniques et fiche de sécurité disponible sur demande / Datos técnicos y ficha de seguridad disponible bajo pedido  
dep.tecnico@pecol.pt

Water-based product, practically odorless which cleans and protects stained and time aged woods.

**Characteristics**

- Cleans and revitalizes all types of wood;
- Retrieves the natural tone of the wood;
- Water Based.

Produit de base aqueuse et pratiquement inodore qui nettoie et protège le Bois taché et vieilli par le passage du temps.

**Characteristics**

- Nettoie et revitalise tous types de Bois;
- Récupère le ton naturel du bois;
- Base Aqueuse.

Producto de base acuosa y prácticamente inodoro que limpia y protege maderas manchadas y envejecidas con el paso del tiempo.

**Characteristics**

- Limpia y revitaliza todo tipo de maderas;
- Recupera el tono natural de la madera;
- Base Acuosa.

CÓDIGO CODE / CODE / CÓDIGO	COR COLOR / COULEUR / COLOR	CAPACIDADE CAPACITY / CAPACITÉ / CAPACIDAD	EMBALAGEM QUANTITY / EMBALLAGE / EMBALAJE
00580400001	Incolor / Colourless / Incolore / Incolore	5 L	1

## PW10 Decapante

PW10 Pickling / PW10 Décapant / PW10 Decapante

Decapante em forma de gel para Madeiras de Interiores e Exteriores.

**Características**

- Não estraga a madeira;
- Não escurece nem desgasta a madeira;
- Não é tóxico, irritante, nem nocivo.

**Dados técnicos e ficha de segurança disponível sob pedido.**  
/ Technical information and safety data sheet available under request / Données techniques et fiche de sécurité disponible sur demande / Datos técnicos y ficha de seguridad disponible bajo pedido  
dep.tecnico@pecol.pt

Pickling gel suitable for Interior and Exterior Wood.

**Characteristics**

- Do not spoil the wood;
- Do not darken or wears wood;
- Non-toxic, irritating or harmful.

Décapant en forme de gel pour Bois d'Intérieurs et d'Extérieurs.

**Characteristics**

- N'endommage pas le bois;
- Ne foncé ni use le bois;
- Non toxique, irritant et nocif.

Decapante em forma de gel para Maderas de Interiores y Exteriores.

**Characteristics**

- No estropea la madera;
- No oscurece ni desgasta la madera;
- No es tóxico, irritante ni nocivo.



CÓDIGO CODE / CODE / CÓDIGO	COR COLOR / COULEUR / COLOR	CAPACIDADE CAPACITY / CAPACITÉ / CAPACIDAD	EMBALAGEM QUANTITY / EMBALLAGE / EMBALAJE
00580400002	Incolor / Colourless / Incolore / Incolore	750 ML	1

## PW10 Óleo Teka

PW10 Oil Teka / PW10 Huile de Teck / PW10 Aceite Teka



Impregnante revitalizador para qualquer tipo de madeira, tanto em interiores como em exteriores. Realça os tons naturais da madeira, potenciando o seu aspeto mais natural.

**Características**

- Mantém o tom mais natural da madeira;
- Elevada resistência aos raios U.V.;
- Hidrofobia a madeira.

**Dados técnicos e ficha de segurança disponível sob pedido.**  
/ Technical information and safety data sheet available under request / Données techniques et fiche de sécurité disponible sur demande / Datos técnicos y ficha de seguridad disponible bajo pedido  
dep.tecnico@pecol.pt

Revitalizing impregnant for any type of wood, both indoors and outdoors. Enhances the natural tones of the wood, maximizing its more natural look.

**Characteristics**

- Maintains wood most natural tone;
- High resistance to U.V. rays;
- Seals the wood.

Impregnant revitalisant pour n'importe quel type de bois, pour intérieurs et extérieurs. Fait ressortir les tons naturels du bois, proportionnant un aspect plus naturel.

**Characteristics**

- Maintient le ton plus naturel du bois;
- Haute résistance aux rayons U.V.;
- Hydrophobie du bois.

Impregnante revitalizador para cualquier tipo de madera, tanto en interiores como en exteriores. Realza los tonos naturales de la madera, potenciando su aspecto más natural.

**Characteristics**

- Mantiene el tono más natural de la madera;
- Elevada resistencia a los rayos U.V.;
- Impermeabiliza la madera.

CÓDIGO CODE / CODE / CÓDIGO	COR COLOR / COULEUR / COLOR	CAPACIDADE CAPACITY / CAPACITÉ / CAPACIDAD	EMBALAGEM QUANTITY / EMBALLAGE / EMBALAJE
00580400005	Incolor / Colourless / Incolore / Incolore	5 L	1

## PW10 Tratamento

PW10 Treatment / PW10 Traitement / PW10 Tratamiento

Impregnante biocida em base solvente com uma excelente capacidade de penetração, tanto em madeiras duras como em madeiras gordurosas (coníferas e tropicais)

**Características**

- Elevada percentagem de biocida (0,40%);
- Protege de ataques do bicho da madeira;
- Compatível com base aquosa ou solvente.

**Dados técnicos e ficha de segurança disponível sob pedido.**  
/ Technical information and safety data sheet available under request / Données techniques et fiche de sécurité disponible sur demande / Datos técnicos y ficha de seguridad disponible bajo pedido  
dep.tecnico@pecol.pt

Biocide impregnant, solvent based, excellent penetration capacity in both hard wood such as in greasy wood (coniferous and tropical).

**Characteristics**

- High percentage of biocide (0.40%);
- Protects the wood from worm attacks;
- Compatible with water-based or solvent.

Impregnant biocide à base de solvant avec une excellente capacité de pénétration, aussi bien sur bois durs comme sur bois gras (conifères et tropicaux).

**Characteristics**

- Pourcentage élevé de biocide (0,40%);
- Protège des attaques de vermoulures;
- Compatible avec base aqueuse ou solvant.

Impregnante biocida em base solvente com uma excelente capacidade de penetração, tanto em madeiras duras como em madeiras gordurosas (coníferas e tropicais)

**Characteristics**

- Elevado porcentaje de biocida (0,40%);
- Protege de ataques del bicho de la madera;
- Compatible con base acuosa o solvente.



CÓDIGO CODE / CODE / CÓDIGO	COR COLOR / COULEUR / COLOR	CAPACIDADE CAPACITY / CAPACITÉ / CAPACIDAD	EMBALAGEM QUANTITY / EMBALLAGE / EMBALAJE
00580400003	Incolor / Colourless / Incolore / Incolore	5 L	1



# VEDAÇÃO E COLAGEM

Sealing and Bonding / Étanche et Collage / Sellado y Pegado

## Massa para Juntas de Alumínio e PVC P250

Aluminium and PVC Bonding and Sealing Glue / Pâte à Joints pour Aluminium et PVC P 250 / Masilla para Juntas de Aluminio y PVC P 250



A Massa para Juntas de Alumínio e PVC P 250 Pecol é um selante monocomponente, elástico e transparente com base em resinas acrílicas em emulsão.

Produto adequado para selar juntas em perfis de alumínio e PVC.

A Massa para Juntas P 250 seca entre sete a dez dias.

### Características

- A Massa para Juntas de Alumínio e PVC P 250 Pecol torna-se transparente quando seco, e permanece inalterado quando se encontra em contacto com água.
- Inodoro
- O produto não curado é de fácil limpeza e remoção, através da limpeza com água;
- Não mancha;
- Muito boa adesão em alumínio, alumínio anodizado e alumínio lacado, assim como em PVC;
- Peso específico: 1,03.

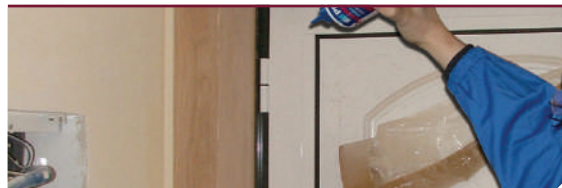

Dados técnicos e ficha de segurança disponível sob pedido.

/ Technical information and safety data sheet available under request / Données techniques et fiche de sécurité disponible sur demande / Datos técnicos y ficha de seguridad disponible bajo pedido dep. tecnico@pecol.pt

A one component, elastic and transparent sealant based on acrylic resins in emulsion.

The product is suitable for sealing aluminium and PVC frames and connection joints.

The product dries totally between seven and ten days.

### Characteristics

- The product becomes transparent when dry and remains unaltered when in contact with water;
- Odorless;
- The uncured product is easy cleaned with water and does not stain the surfaces;
- Very good adhesion on aluminium, anodised and lacquered aluminium and PVC;
- Specific weight: 1.03

La Pâte à Joints pour Aluminium et PVC P 250 est un produit mono-composant, élastique et transparent à base de résine acrylique en émulsion.

Produit adéquat pour étancher les jointes de profilés en aluminium et en PVC.

La Pâte pour joints P 250 sèche entre 7 à 10 jours.

### Caractéristiques

- La Pâte à Joints pour Aluminium et PVC P 250 devient transparente quand elle sèche, et ne s'altère pas au contact de l'eau;
- Inodore;
- Le produit non durci est de facile nettoyage et retrait à l'eau;
- Ne tache pas;
- Très bonne adhésion sur aluminium, aluminium anodisé et aluminium laqué, ainsi que sur le PVC;
- Poids spécifique: 1,03

La Masilla para Juntas de Aluminio y PVC P 250 Pecol es un sellante monocomponente, elástico y transparente con base de resinas acrílicas en emulsión.

Producto adecuado para sellar juntas en perfiles de aluminio y PVC.

La Masilla para Juntas P 250 seca entre siete y diez días.

### Características

- La Masilla para Juntas de Aluminio y PVC P 250 Pecol se vuelve transparente cuando seca, y permanece inalterada cuando se encuentra en contacto con el agua;
- Inodora
- El producto no curado es de fácil limpieza y eliminación, a través de la limpieza con agua;
- No mancha;
- Muy buena adhesión en aluminio, aluminio anodizado y aluminio lacado, así como en PVC;
- Peso específico: 1,03



CÓDIGO CODE / CODE / CÓDIGO	COR COLOR / COULEUR / COLOR	CAPACIDADE CAPACITY / CAPACITÉ / CAPACIDAD	EMBALAGEM QUANTITY / EMBALLAGE / EMBALAJE
00102500000	Transparente / Transparent / Transparent / Transparente	500 g	12



# Vedante Pelúcia

Weatherstrips / Joint Brosse / Burlete de Felpa

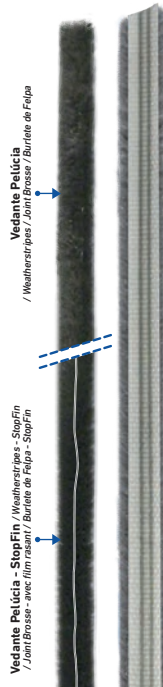

O Vedante Pelúcia é utilizado em perfis de alumínio, tanto em portas como em janelas. É utilizado como isolante, de forma a evitar correntes de ar, passagem de poeiras, luz e outro tipo de contaminantes que possam vir do exterior para o interior através das frestas existentes nas janelas e/ou portas.

A Pelúcia é inserida no interior do perfil de alumínio da janela/porta, atuando como um isolante. O vedante Pelúcia StopFin possui uma fina membrana em Polipropileno que garante um isolamento mais eficiente contra a entrada de correntes de ar e água.

### Características

Calafetagem em suporte de tecido coberto por uma camada de polipropileno que a torna muito rígida e durável. Constituído 100% por polipropileno que evita a formação de bolor. Não é corrosivo.

A Pelúcia da PECOL tem como base silicone, de forma a repelir a água e garantir a resistência aos raios U.V. Fabricado a partir de fibras de multifilamento que se movem independentes uns dos outros, garantindo um isolamento hermético, mesmo em superfícies irregulares. A Pelúcia é ainda sujeita a processos de texturização e configurações térmicas, que lhe confere elevadas propriedades de resistência.



Datos técnicos y ficha de seguridad disponible bajo pedido.  
/ Technical information and safety data sheet available under request / Données techniques e fiche de sécurité disponible sur demande /  
Dados técnicos e ficha de segurança disponível sob pedido  
dep.technico@pecol.pt

Vedante Pelúcia - 4P

Vedante Pelúcia - 3P

Weatherstrips for sliding aluminium windows and doors. It is used as insulation to prevent drafts, dust, light and other contaminants coming in from outside through the edges of windows and doors.

The product is inserted into the aluminium profile of sliding windows, acting as insulation between their panels.

The Weatherstrips StopFin with a very rigid and durable fin which ensure a better insulation to the water and air entering.

### Characteristics

Weatherstripping on woven backing covered by a layer of polypropylene which makes it very rigid and durable.

The strip is made from 100% polypropylene which prevents mildew formation and is also noncorrosive.

The pile of Pecol weatherstripping is siliconized to repel water and is UV stable.

It is manufactured from multi-filament fibres that move independently, guaranteeing an airtight seal even for irregular surfaces. The pile is also subjected to texturizing and heat-setting processes that give it excellent resistance and recovery properties.

Le Joint Brosse est utilisé sur profilés en aluminium, autant sur les porte que sur les fenêtres. Il est utilisé comme isolante, de forme à éviter les courants d'air, passage de poussières, lumière et autres types de contaminant qui puissent venir de l'extérieur vers l'intérieurs au travers de fentes existantes dans les fenêtres et/ou portes.

La Brosse est insérée à l'intérieur du profilé en aluminium de la fenêtre/porte, agissant comme isolant.

Le Joint Brosse avec Film Rasant possède une fine membrane en Polypropylène qui garantit une isolation plus efficace contre l'entrée de courants d'air et eau.

### Caractéristiques

Calfeutrage sur support en tissu couvert par une couche de polypropylène qui devient rigide et durable.

Constitué à 100% par du polypropylène qui évite la formation de moisissures. Non corrosif.

La base de la Brosse PECOL est en silicone, de façon à repousser l'eau et résister aux rayons U.V.

Formulé à partir de fibres de multi-filament qui se meuvent indépendamment les unes des autres, garantissant une isolation hermétique, même en surfaces irrégulières. La Brosse est encore soumise à un processus de texturation et configurations thermiques, qui lui confèrent des propriétés de résistance élevées.

El Burlete de Felpa se utiliza en perfiles de aluminio, tanto en puertas como en ventanas. Se usa como aislante, para evitar corrientes de aire, paso de polvo, luz y otro tipo de contaminantes que puedan venir del exterior para el interior a través de las rendijas existentes en las ventanas y/o puertas. El Burlete se inserta en el interior del perfil de aluminio de la ventana/puerta, actuando como un aislante.

### Características

Calafateado en soporte de tejido cubierto por una capa de polipropileno que lo vuelve muy rígido y duradero.

Fabricado 100% por polipropileno que evita la formación de moho. No es corrosivo.

El Burlete de PECOL tiene como base silicona, de forma que repele el agua y garantiza la resistencia a los rayos U.V. Fabricado a partir de fibras de multifilamento que se mueven independientemente unas de otras, garantizando un aislamiento hermético, incluso en superficies irregulares. El Burlete está además sujeto a procesos de texturización y configuraciones térmicas, que le confiere elevadas propiedades de resistencia.

## Vedante Pelúcia / Weatherstrips / Joint Brosse / Burlete de Felpa

CÓDIGO CODE / CODE / CÓDIGO				LARGURA DA BASE / BASE WIDTH / LARGEUR DE LA BASE / ANCHO DE LA BASE	ALTURA DO PELO / PILE HEIGHT / HAUTEUR DU POIL / ALTO DEL PELO	COMPRIMENTO DA BOBINE / LENGTH OF SPOOL / LONGUEUR DE LA BOBINE / ALTO DE LA BOBINA
Cinza / Grey / Gris / Gris		Preta / Black / Noir / Negra				
3P	4P	3P	4P			
013013650450	-	013023650450	-	6,5 mm	4,5 mm	500 m
013013650550	-	-	-	6,5 mm	5,5 mm	400 m
013013700450	-	-	-	7,0 mm	4,5 mm	450 m
013013700500	-	-	-	7,0 mm	5 mm	450 m
-	-	013023700550	-	7,0 mm	5,5 mm	450 m
013013700550	-	-	-	7,0 mm	5,5 mm	400 m
-	013014700600	013023700600	-	7,0 mm	6,0 mm	400 m
013013700600	-	-	-	7,0 mm	6,0 mm	350 m
013023700651	013014700650	013023700650	-	7,0 mm	6,5 mm	350 m
013013700700	013014700700	013023700700	013024700700	7,0 mm	7,0 mm	350 m
-	-	013024700900	-	7,0 mm	9,0 mm	350 m

## Vedante Pelúcia - StopFin / Weatherstrips - StopFin / Joint Brosse - avec film rasant / Burlete de Felpa - StopFin

CÓDIGO CODE / CODE / CÓDIGO				LARGURA DA BASE / BASE WIDTH / LARGEUR DE LA BASE / ANCHO DE LA BASE	ALTURA DO PELO / PILE HEIGHT / HAUTEUR DU POIL / ALTO DEL PELO
Cinza / Grey / Gris / Gris		Preta / Black / Noir / Negra			
4P	COMPRIMENTO DA BOBINE / LENGTH OF SPOOL / LONGUEUR DE LA BOBINE / ALTO DE LA BOBINA	4P	COMPRIMENTO DA BOBINE / LENGTH OF SPOOL / LONGUEUR DE LA BOBINE / ALTO DE LA BOBINA		
013114700600	400 m	-	-	7,0 mm	6,0 mm
013114700650	350 m	013124700650	450 m	7,0 mm	6,5 mm
013114700700	350 m	13124700700	400 m	7,0 mm	7,0 mm
013114700750	325 m	-	-	7,0 mm	7,5 mm
-	-	13124900700	350 m	7,0 mm	9,0 mm



# VEDAÇÃO E COLAGEM

Sealing and Bonding / Étanche et Collage / Sellado y Pegado

## Massa Reparadora Aqua

Aqua Epoxy Putty Sticks / Tube de Pâte Réparatrice Époxy Aqua / Masilla Reparadora Aqua

A Massa Reparadora – Aqua é uma massa de base Epoxy, utilizada em reparações permanentes em aplicações húmidas, molhadas ou debaixo de água. Este produto é moldável e quando misturado à mão, fica de cor branca, endurece e pode ser perfurado, serrado, limado, lixado ou pintado, se necessário.



Dados técnicos e ficha de segurança disponível sob pedido.  
/ Technical information and safety data sheet available under request / Données techniques et fiche de sécurité disponible sur demande / Datos técnicos y ficha de seguridad disponible bajo pedido  
dep.tecnico@pecol.pt

Celmend Aqua is a resilient epoxy putty used to provide permanent repairs in damp, wet or underwater applications. It is a hand kneadable epoxy putty, when mixed it sets to a hard, white material which can be drilled, sawn, filed or sanded and painted as required.

La pâte réparatrice Aqua est un mastic époxy résistant, utilisé pour fournir des réparations permanentes en applications humides, mouillées ou immergées. Le mastic époxy est pétrissable. Quand mélangé, il durcit et blanchit et peut être percé, scié, met sur un matériau blanc et dur qui peut être percé, scié, limé, poncé et peint selon les besoins.

La Masilla Reparadora – Aqua es una masilla de base Epoxi, utilizada en reparaciones permanentes en aplicaciones húmedas, mojadas o debajo de agua. Este producto es moldeable y cuando es mezclado a mano, queda de color blanco, endurece y puede ser perforado, serrado, limado, lijado o pintado, si necesario.



CÓDIGO  
CODE / CODE  
/ CÓDIGO

COR  
COLOR / COULEUR / COLOR

CAPACIDADE  
CAPACITY / CAPACITÉ /  
CAPACIDAD

EMBALAGEM  
QUANTITY / EMBALLAGE  
/ EMBALAJE

003011500003

Branca  
/ White / Blanc / Blanca

57 gr.

1

## Massa Reparadora Cobre

Copper Epoxy Putty Sticks / Tube de Pâte Réparatrice Époxy Cuivre / Masilla Reparadora Cobre

A Massa Reparadora – Cobre é um produto reforçado de base Epoxy. Este produto endurece rapidamente, e é utilizado para reparar objetos ou tubos em cobre, bronze e outro tipo de metais não ferrosos. Esta massa é moldável, e quando misturada, torna-se num produto de cor idêntica ao cobre, endurece e pode ser perfurado, serrado, limado, lixado ou pintado.



Dados técnicos e ficha de segurança disponível sob pedido.  
/ Technical information and safety data sheet available under request / Données techniques et fiche de sécurité disponible sur demande / Datos técnicos y ficha de seguridad disponible bajo pedido  
dep.tecnico@pecol.pt

Celmend Copper is a copper reinforced epoxy putty. It is fast-setting, and is used to repair objects or tubes in copper, bronze and other nonferrous metals. It is a hand kneadable epoxy putty; when mixed it sets to a hard, copper-coloured material which can be drilled, tapped, machined, filed or sanded and painted as required.

La pâte réparatrice cuivre est un mastic époxy en cuivre renforcé. Il est de prise rapide, et est utilisé pour réparer des objets ou des tuyaux en cuivre, bronze et autres métaux non ferreux. Le mastic époxy est pétrissable. Quand mélangé, il durcit et prend la couleur du cuivre et peut être percé, taraudé, usiné, limé ou poncé et peint selon les besoins.

La Masilla Reparadora – Cobre es un producto reforzado de base Epoxi. Este producto endurece rápidamente, y es utilizado para reparar objetos o tubos en cobre, bronce y otro tipo de metales no ferrosos. Esta masilla es moldeable, y cuando se mezcla, se convierte en un producto de color idéntico al cobre, endurece y puede ser perforada, serrada, limada, lijada o pintada.



CÓDIGO  
CODE / CODE  
/ CÓDIGO

COR  
COLOR / COULEUR / COLOR

CAPACIDADE  
CAPACITY / CAPACITÉ /  
CAPACIDAD

EMBALAGEM  
QUANTITY / EMBALLAGE  
/ EMBALAJE

003011500004

Cobre  
/ Cooper / Cuivre / Cobre

57 gr.

1

## Massa Reparadora Aço

Steel Epoxy Putty Sticks / Pâte Réparatrice Époxy en Tube / Masilla Reparadora Acero

A Massa Reparadora – Aço é uma massa que não enferruja de base Epoxy que proporciona reparações permanentes num curto espaço de tempo em substratos produzidos em metais ferrosos. Este produto é moldável, e quando misturado, torna-se num produto cinza escuro, endurece e pode ser perfurado, serrado, limado, lixado ou pintado.



Dados técnicos e ficha de segurança disponível sob pedido.  
/ Technical information and safety data sheet available under request / Données techniques et fiche de sécurité disponible sur demande / Datos técnicos y ficha de seguridad disponible bajo pedido  
dep.tecnico@pecol.pt

Celmend Steel is a non-rusting steel reinforced epoxy putty used to provide a fast and permanent repairs to items made of ferrous metal. It is a hand kneadable epoxy putty when mixed it sets to a hard, dark grey material which can be drilled, tapped, machined or filed as required.

La pâte réparatrice acier est un mastic époxy antirouille utilisé pour fournir des réparations rapides et permanentes des objets en métal ferreux. Le mastic époxy est pétrissable. Quand mélangé, il durcit et devient gris foncé, il peut être percé, taraudé, usiné ou limé selon les besoins.

La Masilla Reparadora – Acero es una masilla que no oxida de base Epoxi que proporciona reparaciones permanentes en un corto espacio de tiempo en sustratos fabricados en metales ferrosos. Este producto es moldeable, y cuando se mezcla se convierte en un producto gris oscuro, endurece y puede ser perforado, serrado, limado, lijado o pintado.



CÓDIGO  
CODE / CODE  
/ CÓDIGO

COR  
COLOR / COULEUR / COLOR

CAPACIDADE  
CAPACITY / CAPACITÉ /  
CAPACIDAD

EMBALAGEM  
QUANTITY / EMBALLAGE  
/ EMBALAJE

003011500005

Cinza  
/ Grey / Gris / Gris

57 gr.

1



## Massa Reparadora Plástico

Plastic Epoxy Putty Sticks / Tube de Pâte Réparatrice Époxy Plastique / Masilla Reparadora Plástico



A Massa Reparadora – Plástico é uma massa de base Epoxy, utilizada em reparações na maioria dos plásticos rijos, exceto materiais à base de poliolefinas (PP, PE e EPDR). Pode ser moldado à forma pretendida, envolvendo-o na peça a reparar. É uma massa Epoxy moldável, que quando misturada à mão fica de cor branca e endurece, podendo posteriormente ser perfurada, limada, serrada e se necessário, pintada.



Dados técnicos e ficha de segurança disponível sob pedido.  
/ Technical information and safety data sheet available under request / Données techniques et fiche de sécurité disponible sur demande / Datos técnicos y ficha de seguridad disponible bajo pedido  
dep.technico@pecol.pt

Celmead Plastic is a resilient epoxy putty that will bond to all major types of rigid plastics except polyolefines (PP, PE, EPDR). It can be moulded to shape, and wrapped around or built up to repair items. It is a kneadable epoxy putty, when mixed it sets to a hard, white material which can be drilled, sawn, filed or sanded and painted as required.

La pâte réparatrice plastique est un mastic époxy élastique qui est utilisée dans la réparation de tous types de plastique rigide à l'exception des polyoléfinas (PP, PE, EPDR). Il peut être moulé, enroulé ou utilisé pour réparer des objets. Il s'agit d'un mastic époxy malléable. Quand mélangé, il durcit et blanchit et peut être percé, scié, met sur un matériau blanc et dur qui peut être percé, scié, limé, poncé et peint selon les besoins.

La Masilla Reparadora – Aqua es una masilla de base Epoxi, utilizada en reparaciones permanentes en aplicaciones húmedas, mojadas o debajo de agua. Este producto es moldeable y cuando es mezclado a mano, queda de color blanco, endurece y puede ser perforado, serrado, limado, lijado o pintado, si necesario.

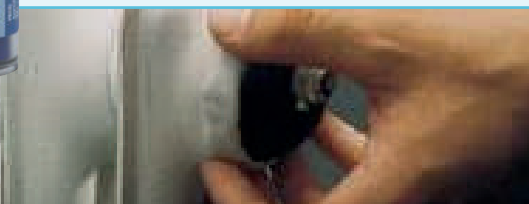

**CÓDIGO**  
CODE / CODE  
/ CÓDIGO

003011500002

**COR**

COLOR / COULEUR / COLOR  
Cinza  
/ Grey / Gris / Gris

**CAPACIDADE**  
CAPACITY / CAPACITÉ /  
CAPACIDAD

57 gr.

**EMBALAGEM**  
QUANTITY / EMBALLAGE  
/ EMBALAJE

1

## Massa Reparadora Alumínio

Aluminium Epoxy Putty Sticks / Tube de Pâte Réparatrice Époxy aluminium / Masilla Reparadora Aluminio

A Massa Reparadora – Alumínio é uma massa Epoxy reforçada, de cura rápida e utilizada para remendar ou reparar tubos, barras e reservatórios de alumínio. É um produto moldável, e quando misturado à mão, fica de cor de alumínio, endurece e pode ser perfurado, maquinado, limado ou pintado se necessário.



Dados técnicos e ficha de segurança disponível sob pedido.  
/ Technical information and safety data sheet available under request / Données techniques et fiche de sécurité disponible sur demande / Datos técnicos y ficha de seguridad disponible bajo pedido  
dep.technico@pecol.pt

Celmead Aluminium is a aluminium reinforced epoxy putty. It is fast setting, and is used to repair, patch or re-form aluminium pipes, rods and tanks. It is a hand kneadable epoxy putty, when mixed it sets to a hard, aluminium-coloured material which can be drilled, lapped, machined, filed or sanded and painted as required.

La pâte réparatrice aluminium est un mastic époxy renforcé. Il est de prise rapide, et est utilisé pour réparer, corriger ou refaire des tubes, tiges et réservoirs en aluminium. Le mastic époxy est pétrissable. Quand mélangé, il durcit et prend la couleur de l'aluminium et peut être percé, taroué, usiné, limé, poncé et peint selon les besoins.

La Masilla Reparadora – Aluminio es una masilla Epoxi reforzada, de cura rápida y utilizada para remendar o reparar tubos, barras o depósitos de aluminio. Es un producto moldeable, y cuando es mezclado a mano, queda de color aluminio, endurece y puede ser perforado, maquinado, limado o pintado si es necesario.

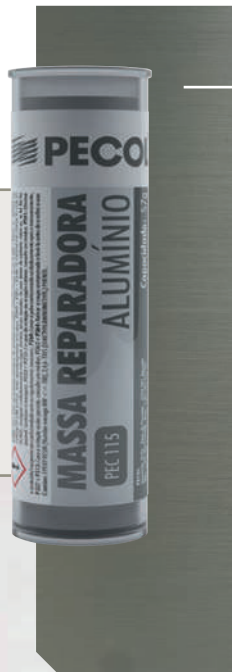

**CÓDIGO**  
CODE / CODE  
/ CÓDIGO

003011500007

**COR**

COLOR / COULEUR / COLOR  
Cinza  
/ Grey / Gris / Gris

**CAPACIDADE**  
CAPACITY / CAPACITÉ /  
CAPACIDAD

57 gr.

**EMBALAGEM**  
QUANTITY / EMBALLAGE  
/ EMBALAJE

1

## Massa Reparadora Madeira

Wood Epoxy Putty Sticks / Tube de Pâte Réparatrice Époxy Bois / Masilla Reparadora Madera



A Massa Reparadora – Madeira é uma massa Epoxy de reduzida densidade, que não perde volume nem se solta da madeira. É um produto de base Epoxy moldável, e quando misturado à mão fica de cor idêntica à madeira, endurece e pode ser perfurada, serrada, esculpida, areada, tingida, colorida ou pintada, se necessário.



Dados técnicos e ficha de segurança disponível sob pedido.  
/ Technical information and safety data sheet available under request / Données techniques et fiche de sécurité disponible sur demande / Datos técnicos y ficha de seguridad disponible bajo pedido  
dep.technico@pecol.pt

Celmead Wood is a low density epoxy putty which will not shrink or pull away from wood. It is a hand kneadable epoxy putty, when mixed it sets to a light wood coloured material which can be drilled, sawn, carved, sanded and stained or painted as required.

La pâte réparatrice bois est un mastic époxy de faible densité qui ne rétrécit et se détache pas du bois. Le mastic époxy est pétrissable. Quand mélangé, il prend la couleur d'un bois clair qui peut être percé, scié, sculpté, poncé, coloré ou peint selon les besoins.

La Masilla Reparadora – Madera es una masilla Epoxi de reducida densidad, que no pierde volumen ni se suelta de la madera. Es un producto de base Epoxi moldeable, y cuando es mezclado a mano queda de color idéntico a la madera, endurece y puede ser perforado, serrado, esculpido, arenado, teñido, coloreado o pintado, si fuese necesario.

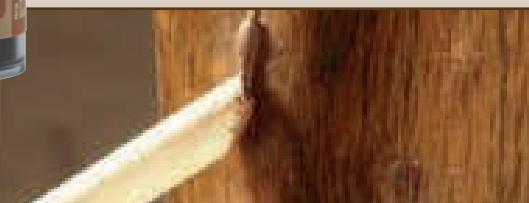

**CÓDIGO**  
CODE / CODE  
/ CÓDIGO

003011500001

**COR**

COLOR / COULEUR / COLOR  
Castanha  
/ Brown / Marron / Marrón

**CAPACIDADE**  
CAPACITY / CAPACITÉ /  
CAPACIDAD

57 gr.

**EMBALAGEM**  
QUANTITY / EMBALLAGE  
/ EMBALAJE

1

## Massa Reparadora Titânio

Titanium Epoxy Putty Sticks / Tube de Pâte Réparatrice Époxy Titane / Masilla Reparadora Titano

A Massa Reparadora – Titânio é um produto resistente a temperaturas elevadas, com base Epoxy reforçado, ideal para reparações de fendas e fissuras em peças, tubos, ferramentas e moldes metálicos. É um produto moldável, e quando misturado à mão fica de cor cinza amarelado, endurece e pode ser perfurado, maquinado ou serrado.



Dados técnicos e ficha de segurança disponível sob pedido.  
/ Technical information and safety data sheet available under request / Données techniques et fiche de sécurité disponible sur demande / Datos técnicos y ficha de seguridad disponible bajo pedido  
dep.technico@pecol.pt

Celmead Titanium is a temperature-resistant. It is a reinforced epoxy putty ideally suited for repairing cracks, breaks, blowholes and threads in metal castings, pipes, tools, patterns and moulds. It is a hand kneadable epoxy putty, when mixed it sets to a hard, yellow-grey material which can be drilled, sawn, filed or sanded as required.

La pâte réparatrice titane est un mastic époxy résistant à la température, idéal pour réparer les fissures, cassures, soufflures et de fils dans les moulages métalliques, tuyaux, outils, modèles et moules. Le mastic époxy est pétrissable. Quand mélangé, il durcit et prend une couleur gris-jaune et peut être percé, scié, limé ou poncé selon les besoins.

La Masilla Reparadora – Titano es un producto resistente a temperaturas elevadas, con base Epoxi reforzado, ideal para reparaciones de hendiduras y fisuras en piezas, tubos, herramientas y moldes metálicos. Es un producto moldeable, y cuando es mezclado a mano queda de color gris amarillento, endurece y puede ser perforado, maquinado o serrado.

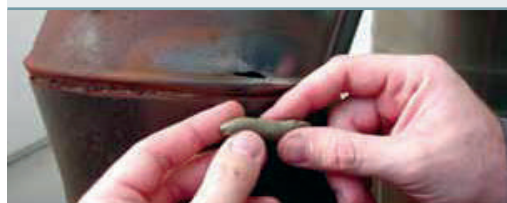

**CÓDIGO**  
CODE / CODE  
/ CÓDIGO

003011500006

**COR**

COLOR / COULEUR / COLOR  
Castanha  
/ Brown / Marron / Marrón

**CAPACIDADE**  
CAPACITY / CAPACITÉ /  
CAPACIDAD

57 gr.

**EMBALAGEM**  
QUANTITY / EMBALLAGE  
/ EMBALAJE

1



# VEDAÇÃO E COLAGEM

Sealing and Bonding / Étanche et Collage / Sellado y Pegado

## Óleo Solúvel P225

Cutting and Cooling Lubricant P 225 / Lubrifiant de Coupe et Refroidissement P 225 / Aceite Soluble P 225



O Óleo Solúvel P225 é um óleo de corte, com base numa formulação ecológica, muito fácil de misturar com água, que cria uma emulsão de cor branca, muito estável e que proporciona um elevado rendimento.

O Óleo Solúvel P225 confere uma boa performance ao nível da lubrificação e da refrigeração, com excelentes propriedades de proteção contra a corrosão em peças metálicas. Adequado para maquinaria leve e pesada.

### Características

- Ajuda a proteger as máquinas da corrosão dos metais;
- A emulsão é estável com qualquer tipo de água (PH);
- Grande capacidade de refrigeração e lubrificação;
- Mantém todos os componentes da máquina a temperatura estável, prevenindo que as peças se partam devido ao sobreaquecimento das mesmas;
- Melhora o desempenho do corte.

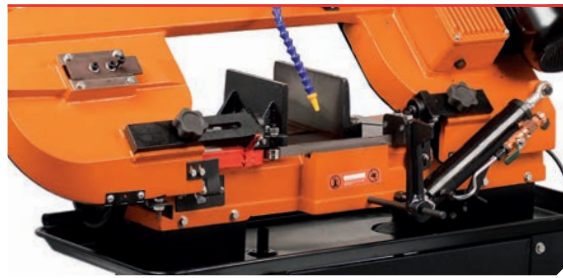

Dados técnicos e ficha de segurança disponível sob pedido.

/ Technical information and safety data sheet available under request / Données techniques et fiche de sécurité disponible sur demande / Datos técnicos y ficha de seguridad disponible bajo pedido  
dep.tecnico@pecol.pt

The P 225 is a cutting oil, with an ecological formulation, very easy to mix with water, creating a white emulsion, very stable and with a high yield. The P 225 provides a high cooling and a lubricating performance with a very good corrosion protection to the metal parts. Suitable for light and heavy machining.

### Characteristics

- It helps to protect the machines and metals parts from corrosion;
- The emulsion is stable with any kind of waters (PH);
- The formulation has a bactericide that prevents the putrefaction and also the bad smells;
- High refrigeration and lubrication capacity;
- Keeps the components at a stable temperature, preventing the breaking of the tools;
- Improves the cutting performance.

Le P 225 est une huile de coupe, avec une formule écologique, très facile à mélanger avec de l'eau, créant une émulsion blanche, très stable et avec un rendement élevé. Le P 225 fournit un refroidissement élevé et une performance de lubrification avec une très bonne protection contre la corrosion des pièces métalliques. Adéquat pour machinerie légère et lourdes.

### Caractéristiques

- Il aide à protéger les machines et les pièces métalliques contre la corrosion;
- L'émulsion est stable avec tout type d'eaux (PH);
- La formule a un bactéricide qui empêche la putréfaction et aussi les mauvaises odeurs;
- Grande capacité de réfrigération et de lubrification;
- Maintient les composants à une température stable, empêchant la rupture des outils;
- Améliore les performances de coupe.

El Aceite Soluble P 225 es un aceite de corte, con base en una formulación ecológica, muy fácil de mezclar con agua, que crea una emulsión de color blanca, muy estable y que proporciona un elevado rendimiento.

El Aceite Soluble P 225 confiere una buena prestación a nivel de la lubricación y de la refrigeración, con excelentes propiedades de protección contra la corrosión en piezas metálicas. Adequado para maquinaria leve y pesada.

### Características

- Ayuda a proteger las máquinas de la corrosión de los metales;
- La emulsión es estable con cualquier tipo de agua (PH);
- Gran capacidad de refrigeración y lubricación;
- Mantiene todos los componentes de la máquina a temperatura estable, previniendo que las piezas se rompan debido al sobrecalentamiento de las mismas;
- Mejora la prestación del corte.



CÓDIGO CODE / CODE / CÓDIGO	CAPACIDADE CAPACITY / CAPACITÉ / CAPACIDAD	EMBALAGEM QUANTITY / EMBALLAGE / EMBALAJE
001022500000	5 l	1



# Massa Consistente

Multi Purpose Grease / Graisse Multifonction / Masilla Consistente

A Massa Consistente EP (Elevada Pressão) é uma massa multifuncional formulada para a lubrificação de cargas médias e pesadas. Concebida para a lubrificação duradoura de correntes, rolamentos, engrenagens e outro tipo de peças metálicas sujeitas a fricção.

Produto isento de chumbo e de qualquer tipo de materiais perigosos para a saúde humana e meio ambiente.

#### Características

- Excelente desempenho durante o funcionamento;
- Aditivos EP, que proporcionam uma elevada resistência à pressão;
- Elevado nível de aderência às peças;
- Proporciona uma boa vedação e proteção contra a corrosão;
- Altamente repelente a poeiras, sujidades e água;
- Resistente a temperaturas entre os -20°C e os +130°C;
- Cor: Castanha;
- Cartucho de 400 gramas;
- Pistola de Aplicação da Massa Consistente vendida em separado.



Dados técnicos e ficha de segurança disponível sob pedido.

/ Technical information and safety data sheet available under request / Données techniques et fiche de sécurité disponible sur demande / Datos técnicos y ficha de seguridad disponible bajo pedido

dep.tecnico@pecol.pt



Multipurpose grease with EP (Extreme pressure) additives for middle and heavy loads. Formulated for long lasting lubrication of chains, bearings, gears and other metal parts subject to friction. The product is lead-free and does not contain other materials with potential danger for human health and environment.

#### Characteristics

- Outstanding performance during running;
- EP additives, providing high pressure resistance;
- Very high adhesion to the parts;
- Provides a good seal and corrosion protection;
- Highly repellent to dust, dirt and water;
- Temperature resistance: -20°C to +130°C;
- Colour: Brown;
- Cartridge of 400 grams;
- Application gun sold separately.

La Graisse Multifonction a des additifs EP (extrême-pression) pour des charges moyennes et lourdes. Conçu pour la lubrification longue durée des chaînes, roulements, engrenages et autres pièces métalliques soumises à la friction. Le produit est sans plomb et ne contient pas d'autres matériaux potentiellement dangereux pour la santé humaine et l'environnement.

#### Caractéristiques

- Des performances exceptionnelles lors de l'utilisation;
- Additifs EP, offrant une résistance à haute pression;
- Très grande adhérence aux supports;
- Assure une bonne étanchéité et protection contre la corrosion;
- Hautement imperméable à la poussière, la saleté et l'eau;
- Résistance à la température: -20 ° C à +130 ° C;
- Couleur: Marron;
- Cartouche de 400 grammes;
- Pistolet d'application vendu séparément.

La Masilla Consistente EP (Elevada Presión) multifunción está formulada para la lubricación de cargas medias y pesadas. Concebida para la lubricación duradera de corrientes, rodamientos, engranajes y otro tipo de piezas metálicas sujetas a fricción. Producto exento de plomo y cualquier tipo de materiales peligrosos para la salud humana y medio ambiente.

#### Características

- Excelente rendimiento durante el funcionamiento;
- Aditivos EP, que proporcionan una elevada resistencia a la presión;
- Elevado nivel de adherencia a las piezas;
- Proporciona un buen sellado y protección contra la corrosión;
- Altamente repelente a polvo, suciedades y agua;
- Resistente a temperaturas entre los -20°C y los +130°C;
- Color: Marrón;
- Cartucho de 400 gramos;
- La Pistola de Aplicación de la Masilla Consistente se vende por separado.

CÓDIGO CODE / CODE / CÓDIGO	COR COLOR / COULEUR / COLOR	CAPACIDADE CAPACITY / CAPACITÉ / CAPACIDAD	EMBALAGEM QUANTITY / EMBALLAGE / EMBALAJE
001034000400	Castanho / Brown / Marron / Marrón	400 g	1

CÓDIGO CODE / CODE / CÓDIGO	EMBALAGEM QUANTITY / EMBALLAGE / EMBALAJE
001034000401	1



Pistola de aplicação da massa consistente  
/ Application gun  
/ Pistolet d'application  
/ Pistola de aplicación de la masilla de rendimiento



# VEDAÇÃO E COLAGEM

Sealing and Bonding / Étanche et Collage / Sellado y Pegado

## Gel Passa Cabos

Gliss Gel / Gel Passe Câbles / Gel Pasa Cables



O Gel Passa Cabos Pecol foi desenvolvido para resolver as dificuldades que muitas vezes aparecem nas instalações de cabos telefónicos, fibra ótica e cabos de alimentação elétrica. Este produto elimina 80% da fricção existente.

O produto é um gel fino de cor branca. A água e o glicol existentes no gel atuam como lubrificantes e formam uma película protetora dos cabos ao longo do tempo.

### Características

- Gel Passa Cabos Pecol é um produto não tóxico, inerte, biodegradável e não inflamável;
- Não produz nenhum efeito de cola.

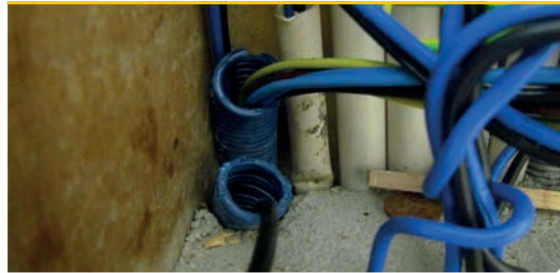

Dados técnicos e ficha de segurança disponível sob pedido.

/ Technical information and safety data sheet available under request / Données techniques et fiche de sécurité disponible sur demande / Datos técnicos y ficha de seguridad disponible bajo pedido  
dep.tecnico@pecol.pt

Pecol Gliss Gel is designed to address the problems related to the installation of electric power, telephone, and fiber optic telephone cables. It eliminates up to 80% of friction.

The product is a thin white gel. The water and glycol in the gelatin act as lubricants as well as vehicles for other specific lubricants which act along the way.

### Characteristics

- Pecol Gliss Gel is a non-toxic, inert, bio-degradable, non-flammable product;
- The product has no glue effect.

Le Gel Passe Câbles Pecol a été développé pour résoudre les difficultés qui apparaissent plusieurs fois dans l'installation de câbles téléphoniques, fibre optique et câbles électriques d'alimentation. Ce produit élimine 80% de la friction existante.

Le produit est un gel fin de couleur blanc. L'eau et le glycol existant dans le gel agissent comme lubrifiants et forment une pellicule protectrice des câbles au long du temps.

### Caractéristiques

- Le Gel Passe Câbles Pecol est un produit non toxique, inerte, biodégradable et non inflammable;
- Ne produit aucun effet de colle.

El Gel Pasa Cables Pecol fue desarrollado para resolver las dificultades que muchas veces aparecen en las instalaciones de cables telefónicos, fibra óptica y cables eléctricos de alimentación. Este producto elimina el 80% de la fricción existente.

El producto es un gel fino de color blanco. El agua y el glicol existentes en el gel actúan como lubricantes y forman una película protectora en los cables a lo largo del tiempo.

### Características

- Gel Pasa Cables Pecol es un producto no tóxico, inerte, biodegradable y no inflamable;
- No produce ningún efecto de adhesión.



CÓDIGO CODE / CODE / CÓDIGO	COR COLOR / COULEUR / COLOR	CAPACIDADE CAPACITY / CAPACITÉ / CAPACIDAD	EMBALAGEM QUANTITY / EMBALLAGE / EMBALAJE
001011500000	Branco / White / Blanc / Blanco	500 ml	12





# Película Protetora Invisível para Vidro

Invisible Glass Protective Film / Film de Protection Invisible pour le Verre / Película Protectora Invisible para Vidrio

Película Protetora Invisível para Vidro é um produto líquido e concentrado, de baixa viscosidade e incolor.

Após aplicação cria uma fina camada protetora invisível.

Repele e dispersa gotas de água e sujidade de poeiras, lamas, gorduras, seiva de árvores.

Não ataca borrachas, plásticos, pinturas, lacados ou cromados.

#### Características

- Fácil aplicação;
- Invisível;
- Repele e dispersa gotas de água e sujidade;
- Não ataca borrachas, plásticos, pinturas, lacados ou cromados.

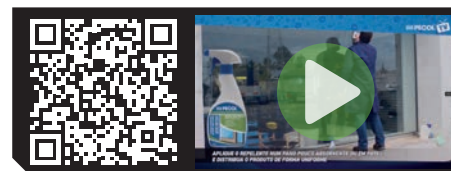
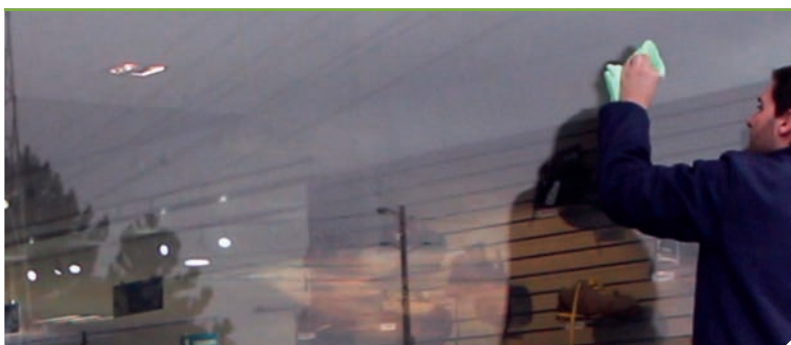

**i** Dados técnicos e ficha de segurança disponível sob pedido.  
/ Technical information and safety data sheet available under request / Données techniques et fiche de sécurité disponible sur demande / Datos técnicos y ficha de seguridad disponible bajo pedido  
dep.tecnico@pecol.pt

Invisible Glass Protective Film is a liquid, concentrated, low viscosity and colourless product.  
After application creates a thin invisible protective layer.  
Repels and disperses water droplets and dirt from dust, sludge, grease, tree sap.  
It does not attack rubbers, plastics, paints, lacquers or chrome-plated.

**Characteristics**

- Easy application;
- Invisível;
- Repels and disperses water droplets and dirt;
- Does not attack rubbers, plastics, paints, lacquers or chrome-plated.

Le Film de Protection Invisible pour le Verre est un produit liquide et concentré, de faible viscosité et incolore.  
Après l'application, il crée une fine couche de protection invisible.  
Repousse et disperse les gouttelettes d'eau et la saleté de la poussière, les boues, la graisse, la sève des arbres.  
Il n'attaque pas les caoutchoucs, plastiques, peintures, laques ou le chrome.

**Caractéristiques**

- Application facile;
- Invisível;
- Repousse et disperse les gouttelettes d'eau et la saleté;
- N'attaque pas les caoutchoucs, plastiques, peintures, laques ou le chrome.

Película Protectora Invisible para Vidrio es un producto líquido y concentrado, de baja viscosidad e incoloro.  
Después de la aplicación crea una fina capa protectora invisible.  
Repetir y dispersar gotas de agua y suciedad de polvo, todos, grasas, savia de árboles.  
No ataca gomas, plásticos, pinturas, lacados o cromados.

**Características**

- Fácil aplicación;
- Invisível;
- Repetir y dispersar gotas de agua y suciedad;
- No ataca gomas, plásticos, pinturas, lacados o cromados.

CÓDIGO CODE / CODE / CÓDIGO	CAPACIDADE CAPACITY / CAPACITÉ / CAPACIDAD	EMBALAGEM QUANTITY / EMBALLAGE / EMBALAJE
003200000042	500 ml	6





**O SEU FORNECEDOR DE SEMPRE,  
ONDE ESTIVER!**

*/ Your ever-ready supplier, wherever you are! / Votre fournisseur de toujours, où que vous soyez! / Su proveedor de siempre, donde esté!*

[HTTP://STORE.PECOL.PT/](http://store.pecol.pt/)

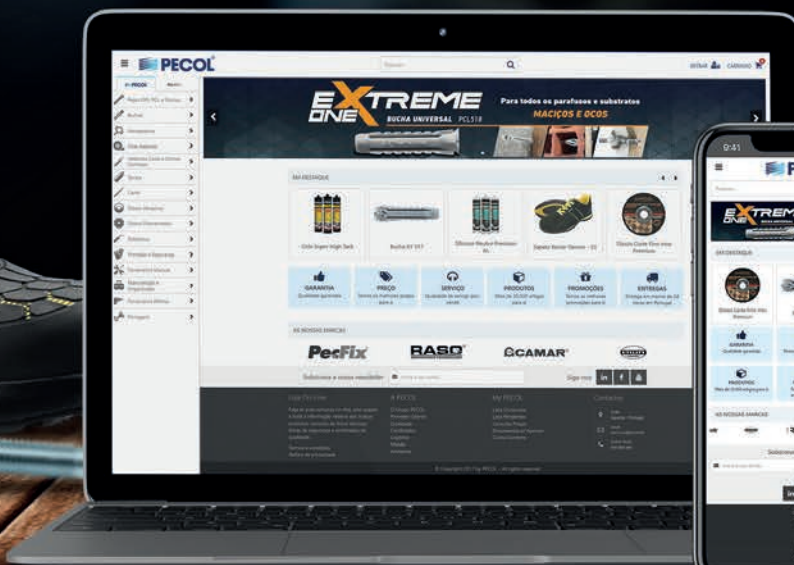



# SPRAYS

SPRAYS  
SPRAYS  
SPRAYS

Protege - Lubrifica - Desoxida  
Protege - lubrica - Desoxida



# SPRAYS

Sprays / Sprays / Sprays

P50 TURBO

LUBRIFICANTES



P240 LUBRIFICANTE MULTIUSOS



P230 LUBRIFICANTE



P180 LUBRIFICANTE CORRENTES



P140 LUBRIFICANTE SECO



P220 ÓLEO CORTE E FURAR



P340 DESENGORDURANTE INDUSTRIAL

LIMPEZA



P210 SUPER DETERGENTE



P120 LIMPEZA ALUMÍNIO E PVC



P90 SILICONE



P70 LIMPEZA DE AÇO INOX



P290 LIMPEZA TRAVÕES



P130 REMOVEDOR DE SILICONES, COLAS E TINTAS



P150 DISSOLVENTE SILICONE



P330 COCKPIT



P350 LIMPEZA DE AR CONDICIONADO



P60 PROTETOR DE SOLDADURA



P65 PROTETOR DE SOLDADURA



P600 DETETOR DE FUGAS



P170 CONTACTOS ELÉTRICOS



P900 COLA



P10 ZINCO CLARO

METÁLICOS



P15 ZINCO BRILHANTE



P20 ZINCO ESCURO



P25 ZINCO MATE



P30 INOX



P40 ALUMÍNIO



P500 LACAGEM E PINCEL DE RETOQUE

PINTURA



P400 PINTURA ACRÍLICA



ALTAS TEMPERATURAS





# Turbo Spray P50 Premium

Spray Turbo P50 Premium / Spray Turbo P50 Premium / Spray Turbo P50 Premium

## LUBRIFICA, PROTEGE, DESBLOQUEIA

O Turbo Spray P50 Premium cobre uma larga variedade de aplicações industriais e de manutenção, devido à sua fórmula especial e excelente capilaridade. Características como proteção à corrosão, resistência à água, lubrificação, conservação e limpeza combinam-se num único produto.

O Spray Turbo P50 Premium não contém Clorofluorcarbonetos (CFC's e HCFC's), cumpre a regulação COV (Composto Orgânico Volátil) e é um produto biodegradável.

Graças ao dispersor e pequeno tubo que vêm juntamente com o Spray P 50, torna-se mais fácil a sua aplicação em locais com difícil acesso.



**i** Dados técnicos e ficha de segurança disponível sob pedido.  
/ Technical information and safety data sheet available under request / Données techniques et fiche de sécurité disponible sur demande / Datos técnicos y ficha de seguridad disponible bajo pedido  
dep.tecnico@pecol.pt

### LUBRICATION, PROTECTION, UNBLOCKING

Turbo Spray P50 Premium covers a wide range of industrial and maintenance applications due to its special formula and excellent creep properties. Corrosion protection, water resistance, lubrication, preservation and cleaning are combined in one product.

Turbo P50 does not contain Chlorofluorocarbons (cfc's and hcfc's), complies with VOC regulations and is biodegradable.

Thanks to the extra nozzle and tube supplied with the product, make it very easy to apply in places which are difficult to access.

### LUBRIFIE, PROTÈGE, DÉBLOQUE

Le Spray Turbo P50 Premium couvre une large variété d'applications industrielles et de maintenance, dû à leur formule spéciale et excellente capillarité. Des caractéristiques comme protection à la corrosion, résistance à l'eau, lubrification, conservation et nettoyage se combine dans un unique produit.

Le Spray Turbo P50 Premium n'a pas de chlore-fluor-carbonates (CFC's et HCFC's), exécute la régulation COV (Composant Organique Volatile) et est biodégradable.

Grâce au disperser et au petit tuyau assemblés au Spray P50, l'application devient plus facile dans des locaux d'accès difficile.

### LUBRICA, PROTEGE, DESBLOQUEA

El Spray Turbo P50 Premium cubre una amplia variedad de aplicaciones industriales y de mantenimiento, debido a su fórmula especial y excelente capilaridad. Características como protección a la corrosión, resistencia al agua, lubricación, conservación y limpieza se combinan en un único producto.

El Spray Turbo P50 Premium no contiene Clorofluorcarbonatos (CFC's e HCFC's), cumple la regulación COV (Compuesto Orgánico Volátil) y es un producto biodegradable.

Gracias al dispersor y pequeño tubo que vienen junto con el Spray P 50, se vuelve más fácil su aplicación en lugares de difícil acceso.

CÓDIGO CODE / CODE / CÓDIGO	CAPACIDADE CAPACITY / CAPACITÉ / CAPACIDAD	EMBALAGEM QUANTITY / EMBALLAGE / EMBALAJE	QTD. PALETTE PALET / QT. PALETTE / CANT. PALÉ
001050000000	400 ml	6	576

# TURBO SPRAY P50

- LUBRIFICA**  
LUBRICATE / LUBRIFIER / LUBRICA
- PROTEGE SUPERFÍCIES**  
PROTECT SURFACES / ZONES DE PROTECTION  
/ PROTEGE SUPERFÍCIES
- REMOVE HUMIDADES**  
ELIMINATE MOISTURE / ÉLIMINE L'HUMIDITÉ  
/ ELIMINA HUMEDADES
- DESBLOQUEIA**  
UNBLOCK / DÉBLOQUE  
/ DESBLOQUEA
- LIMPA CONTACTOS ELÉTRICOS**  
CLEAN ELECTRICAL CONTACTS / NETTOYER  
LES CONTACTS ÉLECTRIQUES / LIMPIA  
CONTACTOS ELÉCTRICOS
- DESOXIDA**  
DEOXIDIZE / DESOXYDE  
/ DESOXIDA

**6 EM 1**  
IN / À / EN



**CASA**  
HOME / MAISON  
/ CASA



**JARDIM**  
GARDEN / JARDIN  
/ JARDÍN



**BRICOLAGE**  
BRICOLAGE / BRICOLAGE  
/ BRICOLAGE



**INDÚSTRIA**  
INDUSTRY / INDUSTRIE  
/ INDUSTRIA



**AUTO**  
AUTO / AUTO  
/ AUTO



**MOTO**  
MOTO / MOTO  
/ MOTO

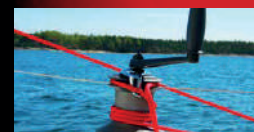

**NÁUTICA**  
NAUTICAL / NAUTIQUE  
/ NAUTICO

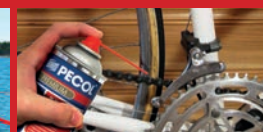

**BICICLETA**  
BICYCLE / BICYCLETTE  
/ BICICLETA



**CONSTRUÇÃO**  
CONSTRUCTION / CONSTRUCTION  
/ CONSTRUCCIÓN



**ELECTRICIDADE**  
ELECTRICITY / ÉLECTRICITÉ  
/ ELECTRICIDAD



**CAÇA**  
HUNTING / CHASSE  
/ CAZA

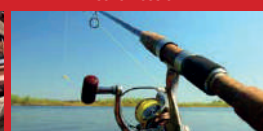

**PESCA**  
FISHING / PÊCHE  
/ PESCA



**FERRAGENS**  
IRON WORK / FERRONNERIE  
/ HERRAJES



**AGRICULTURA**  
AGRICULTURE / AGRICULTURE  
/ AGRICULTURA



**CANALIZAÇÃO**  
PLUMBING / PLÔMBERIE  
/ CANALIZACIONES



# Spray Lubrificante Multiusos P240 Special

Penetrating Lubricant Spray P240 Special / Spray Lubrifiant Multiusages P240 Special / Spray Lubricante P240 Special



O Spray Multiusos P240 Special é um lubrificante à base de uma mistura de óleos minerais e aditivos. O produto atua rapidamente entre as partes enferrujadas e corroídas, de forma a eliminar os pontos de oxidação presentes no metal. Graças à sua excelente propriedade de penetração, o Spray P 240 é adequado para peças que estejam enferrujadas, engorduradas ou sujas. No final da aplicação, o produto deixa uma fina camada que lubrifica e protege a superfície de ferrugens.



**i** Dados técnicos e ficha de segurança disponível sob pedido.  
/ Technical information and safety data sheet available under request / Données techniques et fiche de sécurité disponible sur demande / Datos técnicos y ficha de seguridad disponible bajo pedido  
dep.tecnico@pecol.pt

Penetrating lubricant, based on a blend of petroleum oils and additives. The product quickly flows between rusted and corroded parts to break the bond of oxidized metal. Due to its exceptional penetrating properties it is also suitable for loosening tar, grease, dirt and other carbon deposits. The product leaves a thin film that lubricates and prevents rust.

Le Spray Multiusages P240 Special est un lubrifiant à base d'un mélange d'huiles minérales et additifs. Le produit agit rapidement entre les parties rouillées et rongées, de façon à éliminer les points d'oxydation présentes dans le métal. Grâce à son excellente propriété de pénétration, le spray P240 Special est adéquat pour les pièces qui soient rouillées, graisseuses et sales. À la fin de l'application, le produit laisse une fine couche qui lubrifie et prévient la surface de rouiller.

El Spray Multiusos P240 Special es un lubricante a base de una mezcla de aceites minerales y aditivos. El producto actúa rápidamente entre las partes oxidadas y corroídas, de forma que elimina los puntos de oxidación presentes en el metal. Gracias a su excelente propiedad de penetración, el Spray P240 Special es adecuado para piezas que estén oxidadas, engrasadas o sucias. Tras la aplicación, el producto deja una fina capa que lubrica y previene la superficie de óxidos.

CÓDIGO CODE / CODE / CÓDIGO	CAPACIDADE CAPACITY / CAPACITÉ / CAPACIDAD	EMBALAGEM QUANTITY / EMBALLAGE / EMBALAJE	QTD. PALETE PALET / QT. PALETTE / CANT. PALÉ
001024000000	400 ml	12	576
001024000200	200 ml	12	576

# Spray Lubrificante P230 Premium

Spray on Grease P230 Premium / Spray Lubrifiant P230 Premium / Spray Lubricante P230 Premium



O Spray Lubrificante P230 Premium é um lubrificante sintético resistente a altas pressões, com excelente poder adesivo e excelentes propriedades repelentes de humidade.

O Spray P230 forma uma película lubrificante muito coesa e consistente, reduzindo o ruído e as vibrações durante o funcionamento dos equipamentos.

Excelentes propriedades lubrificantes, com tolerâncias apertadas. Alto poder anti corrosivo.

O produto não salpica quando aplicado em peças em movimento.



**i** Dados técnicos e ficha de segurança disponível sob pedido.  
/ Technical information and safety data sheet available under request / Données techniques et fiche de sécurité disponible sur demande / Datos técnicos y ficha de seguridad disponible bajo pedido  
dep.tecnico@pecol.pt

P230 Premium is an extremely high-pressure resistant synthetic oil with a very good adhesive and moisture displacing properties. Extraordinarily tear-resistant lubricating film with outstanding noise and vibration damping properties. Excellent lubricating properties with close tolerances. Reliably protects against corrosion. No throwing off of the lubricant with turning and rotating parts.

Le Spray Lubrifiant P230 Premium est un lubrifiant synthétique résistant aux hautes pressions, avec un excellent pouvoir d'adhésion et d'excellentes propriétés de répulsion d'humidité. Le Spray P230 forme une pellicule lubrificante très cohérente et consistante, réduisant le bruit et les vibrations pendant le fonctionnement des équipements. Excellentes propriétés lubrifiantes, avec des tolérances serrées. Grand pouvoir anticorrosif. Le produit n'éclabousse pas quand il est appliqué sur des pièces en mouvement.

El Spray Lubricante P230 Premium es un lubricante sintético resistente a altas presiones, con excelente poder adhesivo y excelentes propiedades repelentes de humedad. El Spray P230 forma una película lubricante muy adherente y consistente, reduciendo el ruido y las vibraciones durante el funcionamiento de los equipos. Excelentes propiedades lubricantes, con tolerancias justas. Alto poder anticorrosivo. El producto no salpica cuando se aplica en piezas en movimiento.

CÓDIGO CODE / CODE / CÓDIGO	CAPACIDADE CAPACITY / CAPACITÉ / CAPACIDAD	EMBALAGEM QUANTITY / EMBALLAGE / EMBALAJE	QTD. PALETE PALET / QT. PALETTE / CANT. PALÉ
001023000000	400 ml	6	576



# Spray Lubrificante Correntes P180 Premium

Chain and Rope Lubricant Spray P180 Premium / Spray Lubrifiant Chaîne P180 Premium / Spray Lubricante Cadenas P180 Premium

O Spray Lubrificante para Correntes P180 Premium é um spray lubrificante sintético transparente para lubrificações interiores ou exteriores, em todo o tipo de correntes e cabos de aço. É adequado para diversas áreas de aplicação, tais como, indústria, oficinas mecânicas, automóveis, equipamento marítimo, indústria de bicicletas e motociclos. Previne ainda o alongamento/desgaste de correntes, reduzindo a fricção.

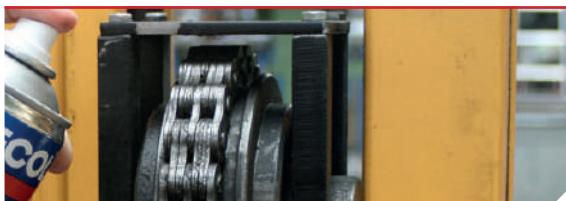

**i** Dados técnicos e ficha de segurança disponível sob pedido.  
/ Technical information and safety data sheet available under request / Données techniques et fiche de sécurité disponible sur demande / Datos técnicos y ficha de seguridad disponible bajo pedido  
dep.tecnico@pecol.pt



The multipurpose chain and rope spray is a synthetic transparent adhesive lubricator for the permanent inside and outside lubrications of all kinds of highly stressed chains and wire cables. It is suitable for several fields of application such as: industry, mechanical car shops, automotive, hardware marine industry, bicycles and motorcycle industry, hardware. The product prevents elongation, friction and wear of the chains, wire cables and steel ropes.

Le Spray Lubrifiant pour Chaînes P180 Premium est un spray lubrifiant synthétique pour lubrifications intérieures et extérieures, en tous types de chaînes et câbles en acier. Adéquat pour diverses zones d'application, telles que l'industrie, garages mécaniques, automobiles, équipements maritime, industrie du vélos et motocycles. Préviens aussi l'allongement/ usure des chaînes, réduisant la friction.

El Spray Lubricante para Cadenas P180 Premium es un spray lubricante sintético transparente para lubricaciones interiores o exteriores, en todo tipo de cadenas y cables de acero. Es adecuado para diversas áreas de aplicación, tales como, industria, talleres mecánicos, automóviles, equipamiento marítimo, Industria de bicicletas y motocicletas. Previene además el alargamiento/desgaste de cadenas, reduciendo la fricción.

CÓDIGO CODE / CODE / CÓDIGO	CAPACIDADE CAPACITY / CAPACITÉ / CAPACIDAD	EMBALAGEM QUANTITY / EMBALLAGE / EMBALAJE	QTD. PALETTE PALET / QT. PALETTE / CANT. PALÉ
001018000001	400 ml	6	576

# Spray Lubrificante Seco PTFE P140 Premium

PTFE Dry Lube Spray P140 Premium / Spray Lubrifiant sec PTFE P140 Premium / Spray Lubricante seco PTFE P140 Premium

O spray lubrificante seco PTFE P140 Premium é um spray isento de silicone e de secagem rápida, que proporciona uma elevada qualidade na lubrificação conferindo uma película protetora na superfície a tratar. O spray lubrificante seco PTFE P140 é um spray incolor, com polytetrafluoroethylene (PTFE) que, após evaporação dos seus solventes, deixa uma camada de lubrificante seco e invisível. A proteção é resistente à sujidade, ao pó, água, óleo, gordura e muitos químicos. A resistência à temperatura é de -60°C a +280°C.

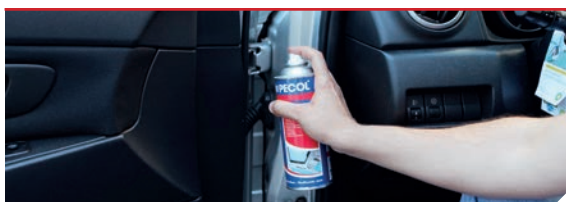

**i** Dados técnicos e ficha de segurança disponível sob pedido.  
/ Technical information and safety data sheet available under request / Données techniques et fiche de sécurité disponible sur demande / Datos técnicos y ficha de seguridad disponible bajo pedido  
dep.tecnico@pecol.pt



Pecol P140 PTFE Dry Lube Premium is a fast drying and silicone free lubricant, that leaves a high quality lubricating and sliding film on treated surface. Thanks to its unique composition, this product provides a dry and almost invisible anti-static layer, thus reducing stick & slip resistance to zero. This dry-film lubricant is a dispersion of colourless, waxy polytetrafluoroethylene (PTFE) that, after evaporation of the solvents, leaves an invisible and completely dry layer of sliding lacquer. The coating is resistant to dirt, dust, water, oils, greases and many chemicals. Temperature resistant is from -60°C to +280°C.

Le spray lubrifiant sec PTFE P140 Premium est un spray sans silicone et de séchage rapide, qui proportionne une grande qualité de lubrification offrant une pellicule protectrice sur la surface à traité. Le spray lubrifiant sec PTFE P140 Premium est un spray incolore, avec polytétrafluoréthylène (PTFE) qui, après évaporation de ces solvants, laisse une couche de lubrifiant sec et invisible. La protection est résistante à la saleté, poussière, eau, huile, graisse et plusieurs produits chimiques. La résistance à la température est de -60°C à +280°C.

El spray lubricante seco PTFE P140 Premium es un spray exento de silicona y de secado rápido, que proporciona una elevada calidad en la lubricación, confiriendo una película protectora en la superficie a tratar. El spray lubricante seco PTFE P140 Premium es un spray incoloro, con Politetrafluoroetileno (PTFE) que, tras evaporación de sus solventes, deja una capa de lubricante seco y invisible. La protección es resistente a la suciedad, al polvo, agua, aceite, grasa y muchos químicos. La resistencia a temperatura es de -60°C a +280°C.

CÓDIGO CODE / CODE / CÓDIGO	CAPACIDADE CAPACITY / CAPACITÉ / CAPACIDAD	EMBALAGEM QUANTITY / EMBALLAGE / EMBALAJE	QTD. PALETTE PALET / QT. PALETTE / CANT. PALÉ
001014000000	400 ml	6	576



# Spray Óleo Corte e Furar P220 Premium

Cutting Oil Spray P220 Premium / Spray Huile Couper et Percer P220 Premium / Spray Aceite Corte y Perforado P220 Premium



O Spray Óleo Corte e Furar P220 Premium é composto por uma mistura de óleos minerais com elevada qualidade lubrificante, perfeito a fazer furos, novas rosças, fresagens e corte de cabos de aço inox e outro tipo de metais. É um produto eficaz quando utilizado em máquinas manuais e semiautomáticas. Lubrifica as peças, reduzindo a temperatura durante o funcionamento da máquina e eliminando as vibrações. O Spray P 220 protege ainda as peças de possíveis corrosões. Produto lavável com água.



Dados técnicos e ficha de segurança disponível sob pedido.

/ Technical information and safety data sheet available under request / Données techniques et fiche de sécurité disponible sur demande / Datos técnicos y ficha de seguridad disponible bajo pedido  
dep.technico@pecol.pt

Cutting oil is a mixture of mineral oils with a high lubricating quality, ideal for drilling, threading, milling and cutting stainless steel and other metals. It is effectively used in manual and semi automatic machining. It lubricates workpieces, lowering their temperatures and eliminating vibrations. It also protects the workpiece by preventing corrosion. The product is washable using water.

Le Spray Huile Couper et Percer P220 Premium est composé d'un mélange d'huiles minérales avec une haute qualité lubrifiante, parfait pour faire des trous, nouveaux filetages, fraisages et coupe de câbles en acier inox et autres types de métaux.

Le produit est efficace quand utilisé sur machines manuelles ou semi-automatiques. Lubrifie les pièces, réduisant la température pendant le fonctionnement de la machine et éliminant les vibrations.

Le Spray P220 Premium protège aussi les pièces de possibles corrosions. Produit lavable à l'eau.

El Spray Aceite Corte y Perforar P220 Premium está compuesto por una mezcla de aceites minerales con elevada calidad lubricante, perfecto para hacer agujeros, nuevas roscas, fresados y corte de cables de acero inox y otro tipo de metales.

Es un producto eficaz cuando se utiliza en máquinas manuales y semiautomáticas. Lubrica las piezas, reduciendo la temperatura durante el funcionamiento de la máquina y eliminando las vibraciones.

El Spray P220 Premium protege además las piezas de posibles corrosiones. Producto lavable con agua.

CÓDIGO CODE / CODE / CÓDIGO	CAPACIDADE CAPACITY / CAPACITÉ / CAPACIDAD	EMBALAGEM QUANTITY / EMBALLAGE / EMBALAJE	QTD. PALETE PALET / QT. PALETTE / CANT. PALÉ
001022000000	400 ml	6	576







# Spray Desengordurante Industrial P340

P340 Industrial Degreaser Spray / Spray Dégraissant P340 / Spray Desengrasante Industrial P340

O Spray Desengordurante Industrial P340 é um produto de limpeza e agente desengordurante de elevadas prestações para a indústria em geral.

Dissolve e remove óleos, gorduras e ceras, sujidade ou outros resíduos que possam causar falhas nos equipamentos industriais.

Desengordura rapidamente e limpa vários substratos sem os danificar e evapora sem deixar resíduos.



Dados técnicos e ficha de segurança disponível sob pedido.

/ Technical information and safety data sheet available under request / Données techniques et fiche de sécurité disponible sur demande / Datos técnicos y ficha de seguridad disponible bajo pedido

dep.tecnico@pecol.pt

P340 Industrial Degreaser Spray is a cleaner and degreasing agent of high performance for the industry in general.

Dissolves and removes oil, grease, wax, dirt or other debris that could cause failures in industrial equipment.

Degreases quickly and clean various materials not damaging them and evaporates leaving no residues.

Le spray dégraissant P340 est un produit de nettoyage dégraissant de haute performance pour l'industrie en général.

Dissout et élimine l'huile, la graisse, la cire, la saleté ou d'autres débris qui pourraient provoquer des défaillances dans l'équipement industriel.

Dégraisse rapidement et nettoie divers substrats sans les endommager et évapore sans laisser de résidus.

El Spray Desengrasante industrial P340 es un agente limpiador y desengrasante de alto rendimiento para la industria en general.

Disuelve y elimina aceite, grasa, cera, suciedad u otros residuos que podrían causar fallos en equipos industriales.

Desengrasa y limpia rápidamente diversos materiales sin dañarlos y se evapora sin dejar residuos.

CÓDIGO CODE / CODE / CÓDIGO	CAPACIDADE CAPACITY / CAPACITÉ / CAPACIDAD	EMBALAGEM QUANTITY / EMBALLAGE / EMBALAJE	QTD. PALETTE PALET / QT. PALETTE / CANT. PALÉ
001034000000	500 ml	6	576

# Spray Super Detergente P210

Super Cleaner Spray P210 / Spray Super Détergent P210 / Spray Super Detergente P210

O Spray Super Detergente P210 limpa e desengordura todo o tipo de superfícies metálicas, vidros, cerâmicas e a maioria dos plásticos. O Spray evapora rapidamente sem deixar marcas. Não fica presente nenhum tipo de camada de resíduos, ao contrário do uso de diluentes. Mesmo quando existem lubrificantes viscosos, os mesmos são eliminados.

Graças à sua válvula especial, o Spray Super Detergente P210 pode ser aplicado em qualquer direção/posição.



Dados técnicos e ficha de segurança disponível sob pedido.

/ Technical information and safety data sheet available under request / Données techniques et fiche de sécurité disponible sur demande / Datos técnicos y ficha de seguridad disponible bajo pedido

dep.tecnico@pecol.pt

P210 cleans and degreases all metal surfaces, glass, ceramics and most plastics. It evaporates quickly and works without residue. No residual layer remains as is the case when thinners are used. Even gummy lubricants are removed.

Thanks to its special valve the P210 spray can may be used in any position.

Le Spray Super Détergent P210 nettoie et dégraisse tous types de surfaces métalliques, verre, céramiques et la plupart des plastiques. Le Spray évapore rapidement sans laisser de marques. Aucun type de couche de résidus ne se forme, au contraire de l'utilisation de diluant. Même quand il existe des lubrifiants visqueux, ils sont éliminés.

Grâce à sa valve spéciale, le Spray Super Détergent P210 peut être appliqué dans n'importe quelle direction/position.

El Spray Super Detergente P210 limpia y desengrasa todo tipo de superficies metálicas, vidrios, cerámicas y la mayoría de los plásticos. El Spray evapora rápidamente sin dejar marcas. No queda presente ningún tipo de capa de residuos, al contrario que en el uso de diluyentes. Incluso cuando existen lubricantes viscosos, estos son eliminados.

Gracias a su válvula especial, el Spray Super Detergente P210 puede ser aplicado en cualquier dirección/ posición.

CÓDIGO CODE / CODE / CÓDIGO	CAPACIDADE CAPACITY / CAPACITÉ / CAPACIDAD	EMBALAGEM QUANTITY / EMBALLAGE / EMBALAJE	QTD. PALETTE PALET / QT. PALETTE / CANT. PALÉ
001021000000	500 ml	6	576



## SPRAYS

Sprays / Sprays / Sprays

# Spray Limpeza de Vidro e Alumínio P120

Glass and Aluminium Spray Cleaner P120 / Spray Nettoyant de Vitre et Aluminium P120 / Spray Limpieza de Vidrio y Aluminio P120



Spray de alta qualidade para limpeza de janelas de vidro e espelhos, assim como caixilharias de alumínio. O produto tem forma de espuma, fácil de aplicar e com excelentes propriedades de dissolução.

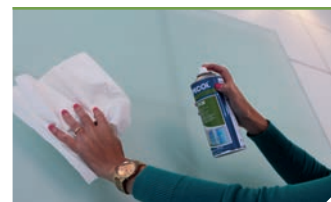

Dados técnicos e ficha de segurança disponível sob pedido.  
/ Technical information and safety data sheet available under request / Données techniques et fiche de sécurité disponible sur demande / Datos técnicos y ficha de seguridad disponible bajo pedido

dep.tecnico@pecol.pt

High quality spray to clean window glass and mirrors as well as aluminium frames. The product has a form of white foam, is easy to apply and high dissolving properties.

Spray de haute qualité pour nettoyage de vitre et miroirs, ainsi que de cadres en aluminium.  
Le produit a la forme d'une mousse, facile d'appliquer et avec d'excellentes propriétés de dissolution.

Spray de alta calidad para limpieza de cristales y espejos, así como estructuras de aluminio.  
El producto tiene forma de espuma, fácil de aplicar y con excelentes propiedades de disolución.

CÓDIGO CODE / CODE / CÓDIGO	CAPACIDADE CAPACITY / CAPACITÉ / CAPACIDAD	EMBALAGEM QUANTITY / EMBALLAGE / EMBALAJE	QTD. PALETE PALET / QT. PALETTE / CANT. PALÉ
001012000000	400 ml	6	576

# Spray Silicone P90

Silicone Spray P90 / Spray Silicone P90 / Spray Silicona P90



O Spray Silicone P90 é um óleo de baixa viscosidade, adequado para a lubrificação de metais e superfícies não-metálicas, tais como guias, tapetes rolantes, transportadores, facas de corte, madeira, borracha e vinil. Este produto produz uma camada protetora resistente e duradoura. Protege componentes elétricos, sendo perfeito ainda para ambientes húmidos e meio marítimo. Este spray não pode ser aplicado em zonas a serem pintadas ou em equipamento elétrico sob tensão. Deve sempre assegurar que os resíduos do spray são removidos para permitir uma futura utilização.



Dados técnicos e ficha de segurança disponível sob pedido.  
/ Technical information and safety data sheet available under request / Données techniques et fiche de sécurité disponible sur demande / Datos técnicos y ficha de seguridad disponible bajo pedido

dep.tecnico@pecol.pt

The Silicone Spray is a general purpose low viscosity silicone oil, suitable for lubricating metal and non-metal surfaces e.g. guides, conveyors, cutting knives as well as rubber, wood and vinyl.

It provides a durable separating film and good surface properties. Also protects electrical parts and is perfect for wet environments and marine use.

The silicone oil cannot be used in areas where painting is undertaken and on live electrical equipment. Always ensure that aerosol vapors are removed or allowed to dissipate fully prior to re-use.

Le Spray Silicone P90 est une huile de basse viscosité, adéquat pour lubrifier des métaux ou des surfaces non-métalliques, tels que les guides, tapis roulants, transporteurs, couteau de coupe, bois, caoutchouc et vinyle.

Le spray produit une couche protectrice résistante et durable. Protège les composants électriques et est également parfait pour des environnements humides et milieu maritime.

Le spray ne peut pas être appliqué en zones à être peintes ou en équipements électriques sous tension.  
Il faut toujours garantir que les résidus de spray sont retirés pour permettre une future utilisation.

El Spray Silicona P90 es un aceite de baja viscosidad, adecuado para la lubricación de metales y superficies no-metálicas, tales como guías, cintas deslizantes, transportadoras, cuchillos de corte, madera, caucho y vinilo. Este producto produce una capa protectora resistente y duradera. Protege componentes eléctricos, siendo perfecto además para ambientes húmedos y medio marítimo.

Este spray no puede ser aplicado en zonas que vayan a ser pintadas o en equipos eléctricos bajo tensión. Debe siempre asegurar que los residuos del spray son eliminados para permitir una futura utilización.

CÓDIGO CODE / CODE / CÓDIGO	CAPACIDADE CAPACITY / CAPACITÉ / CAPACIDAD	EMBALAGEM QUANTITY / EMBALLAGE / EMBALAJE	QTD. PALETE PALET / QT. PALETTE / CANT. PALÉ
001090000000	400 ml	6	576



# Spray Proteção e Limpeza de Aço Inox P70

Stainless Steel Care Spray P70 / Spray de Protection et Nettoyage d'Acier Inox P70 / Spray Protección y Limpieza de Acero Inox P70

O Spray Proteção e Limpeza de Aço Inox P70 foi desenvolvido especialmente para limpar, cuidar e proteger Superfícies de Aço Inox fosco e polido, quer seja em interiores ou exteriores. Este produto tem um efeito anti estático.

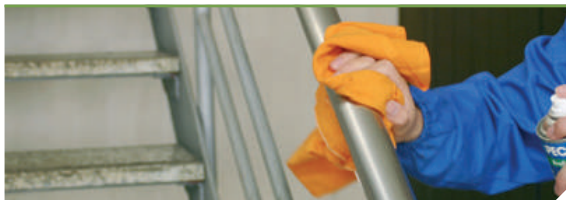

**i** Dados técnicos e ficha de segurança disponível sob pedido.  
/ Technical information and safety data sheet available under request / Données techniques et fiche de sécurité disponible sur demande / Datos técnicos y ficha de seguridad disponible bajo pedido  
dep.tecnico@pecol.pt

Pecol Stainless Steel Care Spray is specially developed for cleaning, care and protection of matt and polished stainless steel surfaces, indoor and outdoors. This spray has an antistatic effect.

Le Spray de Protection et Nettoyage d'Acier Inox P70 a été développé spécialement pour nettoyer, prendre soin et protéger les surfaces en Acier Inox terne et poli, soit en intérieurs ou en extérieurs. Le produit a un effet antistatique.

El Spray Protección y Limpieza de Acero Inox P70 fue desarrollado especialmente para limpiar, cuidar y proteger Superfícies de Acero Inox mate y pulido, sea en interiores o exteriores. Este producto tiene un efecto antiestático.

CÓDIGO CODE / CODE / CÓDIGO	CAPACIDADE CAPACITY / CAPACITÉ / CAPACIDAD	EMBALAGEM QUANTITY / EMBALLAGE / EMBALAJE	QTD. PALETTE PALET / QT. PALETTE / CANT. PALÉ
001070000000	400 ml	6	576

# Spray Limpeza de Travões P290

Brake Cleaner Spray P290 / Spray Nettoyant de Freins P290 / Spray Limpieza de Frenos P290

O Spray Limpeza de Travões P290 é um produto de grande qualidade, com base em Hidrocarbonetos Alifáticos e tem uma aplicabilidade universal como spray de limpeza, especialmente na indústria automóvel. Comparativamente a outros solventes de limpeza convencionais, o Spray Limpeza de Travões P290 evapora sem deixar resíduos.

Rapidamente desengordura e limpa metais, vidros e vários tipos de plásticos sem qualquer dificuldade.

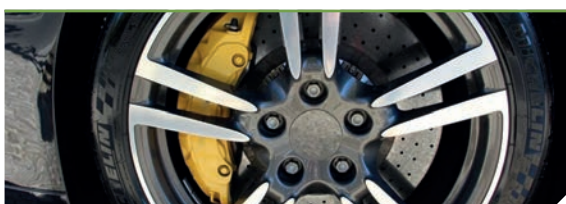

**i** Dados técnicos e ficha de segurança disponível sob pedido.  
/ Technical information and safety data sheet available under request / Données techniques et fiche de sécurité disponible sur demande / Datos técnicos y ficha de seguridad disponible bajo pedido  
dep.tecnico@pecol.pt

P290 is a high quality product based on aliphatic hydrocarbon and works as a universal cleaner especially for automotive applications. In comparison with conventional thinners, P290 Brake Cleaner evaporates without residue. It quickly degreases and cleans metals, glass and many plastics without a problem.

Le Spray Nettoyant de Freins P290 est un produit de grande qualité, à base d'hydrocarbures Aliphatiques et a applicabilité universelle comme spray de nettoyage, spécialement dans l'industrie automobile. Comparativement à d'autres solvants de nettoyage conventionnels, le Spray Nettoyant de Freins P290 évapore sans laisser de résidus. Il dégraisse et nettoie rapidement les métaux, verres et plusieurs types de plastiques sans aucune difficulté.

El Spray Limpieza de Frenos P290 es un producto de gran calidad, con base en Hidrocarburos Alifáticos y tiene una aplicabilidad universal como spray de limpieza, especialmente en la industria automóvil. Comparativamente a otros solventes de limpieza convencionales, el Spray Limpieza de Frenos P290 evapora sin dejar residuos. Rápidamente desengrasa y limpia metales, vidrios y varios tipos de plásticos sin ninguna dificultad.

CÓDIGO CODE / CODE / CÓDIGO	CAPACIDADE CAPACITY / CAPACITÉ / CAPACIDAD	EMBALAGEM QUANTITY / EMBALLAGE / EMBALAJE	QTD. PALETTE PALET / QT. PALETTE / CANT. PALÉ
001029000000	500 ml	6	576



# Spray Removedor Silicones, Colas e Tintas P130

Sealant and Adhesive Remover P130 / Spray Nettoyant de Silicones, Colles et Peintures P130 / Spray Eliminator Siliconas, Adhesivos y pinturas P130

**Indicado para produtos curados** / Indicated for cured parts / Indiqué pour Produit Durci / Indicado para Producto Curado

O Spray P130 dissolve-se rapidamente e elimina resíduos de silicones e selantes já curados, assim como vernizes e tintas, sem qualquer dificuldade, mesmo em superfícies verticais.

É um produto muito eficaz para remover silicones em substratos como a pedra, metal e madeira.

De fácil aplicação, eficaz e com um grande poder de penetração.

Não deve ser aplicado em plásticos sensíveis/frágeis, tais como o PVC, linéoleos sintéticos, lacados, entre outros.



**Dados técnicos e ficha de segurança disponível sob pedido.**

/ Technical information and safety data sheet available under request / Données techniques et fiche de sécurité disponible sur demande / Datos técnicos y ficha de seguridad disponible bajo pedido  
dep.tecnico@pecol.pt

P130 dissolves and quickly eliminates sealant and hardened adhesive residues, as well as lacquers and paints, without a problem, even on vertical surfaces.

This is a high quality effective tool to remove silicones on surfaces of stone, metal and wood.

Easy to apply, very effective with a good penetrating quality.

It should not be used with sensitive plastics like PVC, synthetics linoleum, lacquers and so on.

Le Spray P130 se dissout rapidement et élimine les résidus de silicones et mastics déjà durcis ainsi que les vernis et peintures, sans aucune difficulté, même sur surfaces verticales.

Le produit est très efficace pour retirer le silicone de supports en pierre, métal et bois.

De facile application, efficace et avec un grand pouvoir de pénétration.

Ne doit pas être appliqué sur plastiques sensibles/fragiles, tels que le PVC, linéoleum synthétique, laques, entre autres.

El Spray P130 se disuelve rápidamente y elimina residuos de siliconas y sellantes ya curados, así como barnices y pinturas, sin ninguna dificultad, incluso en superficies verticales.

Es un producto muy eficaz para eliminar siliconas en materiales como piedra, metal y madera.

De fácil aplicación, eficaz y con un gran poder de penetración.

No debe ser aplicado en plásticos sensibles/frágiles, tales como PVC, linéoleos sintéticos, lacas, entre otros.

CÓDIGO CODE / CODE / CÓDIGO	CAPACIDADE CAPACITY / CAPACITÉ / CAPACIDAD	EMBALAGEM QUANTITY / EMBALLAGE / EMBALAJE	QTD. PALETE PALET / QT. PALETTE / CANT. PALÉ
001013000000	400 ml	6	576

# Spray Dissolvente Silicone P150

Silicone Solvent P150 / Spray Dissolvant Silicone P150 / Spray Disolvente Silicona P150

**Indicado para produtos não curados** / Indicated for Uncured Product / Indiqué pour Produit Non Durci / Indicado para Producto No Curado

O Spray P150 é um Dissolvente de Silicone de elevada qualidade, com base em hidrocarbonetos alifáticos. É um produto muito eficaz na remoção de gorduras, silicones, óleos, sujidades e poeiras existentes em superfícies tais como pedra, metal e madeira.

Uma vez aplicado sobre o produto não curado, este spray dissolve o Silicone e limpa a superfície.



**Dados técnicos e ficha de segurança disponível sob pedido.**

/ Technical information and safety data sheet available under request / Données techniques et fiche de sécurité disponible sur demande / Datos técnicos y ficha de seguridad disponible bajo pedido  
dep.tecnico@pecol.pt

P150 is a high quality solvent cleaner, based on aliphatic hydrocarbons, and is a effective tool to remove grease, silicones, oil dirt and dust on surfaces such as stone, metal and wood.

Once applied over the uncured product it solves the silicone and cleans the surfaces.

Le Spray P150 est un Dissolvant de Silicone de grande qualité, à base d'hydrocarbures alyphatiques. Le produit est très efficace dans le retrait de graisses, silicones, huiles, saletés et poussières existantes sur les surfaces comme la pierre, métal et bois.

Une fois appliqué sur le produit non durci, le spray dissout le silicone et nettoie la surface.

El Spray P150 es un Disolvente de Silicona de elevada calidad, con base en hidrocarburos alifáticos. Es un producto muy eficaz en la eliminación de grasas, siliconas, aceites, suciedades y polvo existentes en superficies tales como piedra, metal y madera.

Una vez aplicado sobre el producto no curado, este spray disuelve la Silicona y limpia la superficie.

CÓDIGO CODE / CODE / CÓDIGO	CAPACIDADE CAPACITY / CAPACITÉ / CAPACIDAD	EMBALAGEM QUANTITY / EMBALLAGE / EMBALAJE	QTD. PALETE PALET / QT. PALETTE / CANT. PALÉ
001015000000	400 ml	6	576



## Spray Cockpit P330

Cleaning and Care Cockpit Spray P330 / Spray Cockpit P330 / Spray Cockpit P330

O Spray Cockpit P330 é um produto de limpeza de grande qualidade que limpa, protege e embeleza o painel e outro tipo de plásticos do interior dos carros.

O produto, uma vez aplicado, cria uma película protetora que perdura durante um longo período de tempo, reanimando as cores e deixando um brilho fosco e sedoso. Este Spray prolonga ainda o tempo de vida dos componentes dos plásticos.



Dados técnicos e ficha de segurança disponível sob pedido.

/ Technical information and safety data sheet available under request / Données techniques et fiche de sécurité disponible sur demande / Datos técnicos y ficha de seguridad disponible bajo pedido

dep.tecnico@pecol.pt

Cockpit spray is a high quality spray to clean, protect and embellish the dashboard and other plastic in the car.

The product, once applied, leaves a protective layer that stays for a long time, revives colours and leaves a silky matt shine. The product extend the life time of the plastic components.

Le Spray Cockpit P330 est un produit de nettoyage de grande qualité qui nettoie, protège et embellit le panneau et autres types de plastiques de l'intérieur des voitures.

Le produit, une fois appliqué, crée une pellicule protectrice qui perdure pendant une longue période de temps, réanimant les couleurs et laissant une brillance dépoli et soyeuse. Le Spray prolonge le temps de vie des composants des plastiques.

El Spray Cockpit P330 es un producto de limpieza de gran calidad que limpia, protege y embellece el panel y otro tipo de plásticos del interior de los coches. El producto, una vez aplicado, crea una película protectora que perdura durante un largo período de tiempo, reavivando los colores y dejando un brillo mate y sedoso. Este Spray prolonga además el tiempo de vida de los componentes de los plásticos.

CÓDIGO CODE / CODE / CÓDIGO	CAPACIDADE CAPACITY / CAPACITÉ / CAPACIDAD	EMBALAGEM QUANTITY / EMBALLAGE / EMBALAJE	QTD. PALETTE PALET / QT. PALETTE / CANT. PALÉ
001033000000	400 ml	6	576

## Spray Limpeza de Ar Condicionado P350

Air Conditioning Cleaner P350 / Spray Nettoyage de Climatisation P350 / Spray Limpieza de Aire Acondicionado P350

O Spray de Limpeza de Ar Condicionado é uma espuma de elevada qualidade para a limpeza de aparelhos de Ar Condicionado em veículos, habitações, entre outros.

É um produto muito eficaz quer na limpeza quer na desinfestação dos aparelhos.

Não atua somente como um produto para renovar e melhorar o cheiro do ar, mas garante ainda que odores a bolor e a mofo sejam eliminados, devido à ação fungicida e bactericida do Spray.



Dados técnicos e ficha de segurança disponível sob pedido.

/ Technical information and safety data sheet available under request / Données techniques et fiche de sécurité disponible sur demande / Datos técnicos y ficha de seguridad disponible bajo pedido

dep.tecnico@pecol.pt

High quality effective foam to clean the air-conditioning system in vehicles and domestic A/C appliances.

This is a highly effective product for cleaning and disinfecting, which does not just act as a cosmetic odour cover-up but also ensures that mouldy smells are effectively eliminated at source by killing mildew and fungi.

Le Spray de Nettoyage de Climatisation est une mousse de haute qualité pour le nettoyage d'appareils de climatisation en habitations, véhicules entre autres.

Le produit est très efficace aussi bien dans le nettoyage que dans la désinfection des appareils.

Il n'agit pas seulement comme un produit pour rénover et améliorer l'odeur de l'air, mais garantit encore que l'odeur de moisissure et renfermé soit éliminée, dû à l'action fongicide et bactéricide du Spray.

El Spray de Limpieza de Aire Acondicionado es una espuma de elevada calidad para la limpieza de aparatos de Aire Acondicionado en vehículos, habitaciones, entre otros.

Es un producto muy eficaz ya sea en la limpieza como en la desinfección de los aparatos.

No actúa solamente como un producto para renovar y mejorar el olor del aire, sino que también garantiza que olores a moho sean eliminados, debido a la acción fungicida y bactericida del Spray.

CÓDIGO CODE / CODE / CÓDIGO	CAPACIDADE CAPACITY / CAPACITÉ / CAPACIDAD	EMBALAGEM QUANTITY / EMBALLAGE / EMBALAJE	QTD. PALETTE PALET / QT. PALETTE / CANT. PALÉ
001035000000	400 ml	6	576



## SPRAYS

Sprays / Sprays / Sprays

# Spray Protetor de Soldadura P60

Welding Protection Spray P60 / Spray Protecteur de Soudure P60 / Spray Protetor de Soldadura P60



O Spray Protetor de Soldadura P60 é um produto não inflamável de elevada qualidade, com base em óleos e solventes, utilizado para limpar os bicos das pistolas MIG MAG, mantendo-os limpos.

O Spray P60 protege os bicos das pistolas e os substratos soldados de salpicos de solda, sem prejudicar o cordão de solda.



Dados técnicos e ficha de segurança disponível sob pedido.

/ Technical information and safety data sheet available under request / Données techniques et fiche de sécurité disponible sur demande / Datos técnicos y ficha de seguridad disponible bajo pedido  
dep.technico@pecol.pt

P60 is a non - flammable high quality product based on oil and solvents, used to clean welding nozzles and keep them clean.

Welding Protection Spray prevents weld spatters from sticking to gas nozzles and workpiece surfaces without impairing the weld seam.

Le Spray Protecteur de soudure P60 est un produit non inflammable de haute qualité, à base d'huiles et solvants, utilisés pour nettoyer les pointes des pistolets MIG MA, les maintenant propres.

Le spray P60 protège les pointes des pistolets et les supports soudés des éclaboussures de soude, sans nuire le cordon de soudure.

El Spray Protector de Soldadura P60 es un producto no inflamable de alta calidad, con base de aceites y disolventes, utilizado para limpiar las boquillas de las pistolas MIG MAG, manteniéndolos limpios.

El Spray P60 protege las boquillas de las pistolas y los materiales soldados de salpicaduras de la soldadura sin dañar el cordón de soldadura.

CÓDIGO CODE / CODE / CÓDIGO	CAPACIDAD CAPACITY / CAPACITÉ / CAPACIDADE	EMBALAJE QUANTITY / EMBALLAGE / EMBALAGEM	CANT. PALÉ PALET / QT. PALETTE / QTD. PALETTE
P60 001060000000	400 ml	6	576

# Spray Protetor de Soldadura P65

Welding Protection Spray P65 / Spray Protecteur de Soudure P65 / Spray Protetor de Soldadura P65



O Spray Protetor de Soldadura P65 é um produto não inflamável de elevada qualidade, de base aquosa, utilizado para limpar os bicos das pistolas MIG MAG, mantendo-os limpos.

O Spray P65 é livre de silicone e protege os bicos das pistolas e os substratos soldados de salpicos de solda, sem prejudicar o cordão de solda.



Dados técnicos e ficha de segurança disponível sob pedido.

/ Technical information and safety data sheet available under request / Données techniques et fiche de sécurité disponible sur demande / Datos técnicos y ficha de seguridad disponible bajo pedido  
dep.technico@pecol.pt

P65 is a non - flammable high quality water-based product, used to clean welding nozzles and keep them clean.

P65 is a free of silicone welding protection spray that prevents weld spatters from sticking to gas nozzles and workpiece surfaces without impairing the weld seam.

Le Spray Protecteur de soudure P65 est un produit non inflammable de haute qualité, à base d'eau, utilisés pour nettoyer les pointes des pistolets MIG MA, les maintenant propres.

Le spray P65, sans silicone, protège les pointes des pistolets et les supports soudés des éclaboussures de soude, sans nuire le cordon de soudure.

El Spray Protector de Soldadura P65 es un producto no inflamable de alta calidad, con base acuosa, utilizado para limpiar las boquillas de las pistolas MIG MAG, manteniéndolos limpios.

El Spray P65 es libre de silicona y protege las boquillas de las pistolas y los materiales soldados de salpicaduras de la soldadura sin dañar el cordón de soldadura.

CÓDIGO CODE / CODE / CÓDIGO	CAPACIDAD CAPACITY / CAPACITÉ / CAPACIDADE	EMBALAJE QUANTITY / EMBALLAGE / EMBALAGEM	CANT. PALÉ PALET / QT. PALETTE / QTD. PALETTE
P65 001062000000	300 ml	6	576



## Spray Detetor de Fugas P600

Leak Detector P600 / Spray Détecteur de Fuites P600 / Spray Detetor de Fugas P600

O Spray Detetor de Fugas P600 é um produto de elevada qualidade com base aquosa e aditivos. Este produto deteta fugas num curto espaço de tempo, de uma forma segura.

O produto é biodegradável, não inflamável, não é venenoso nem corrosivo.

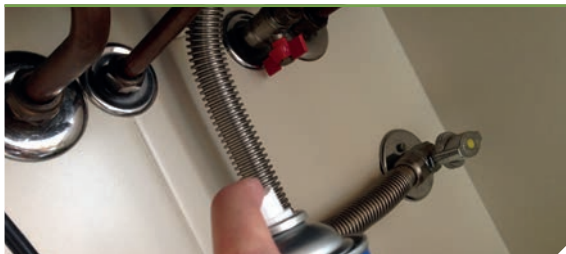

Dados técnicos e ficha de segurança disponível sob pedido.

/ Technical information and safety data sheet available under request / Données techniques et fiche de sécurité disponible sur demande / Datos técnicos y ficha de seguridad disponible bajo pedido  
dep.technico@pecol.pt



Leak detector is a high quality product based on water and additives. This product finds a leak in a quick and safe manner.  
The product is biodegradable and is not flammable, poisonous and corrosive.

Le Spray Détecteur de Fuites P600 est un produit de grande qualité de base aqueuse et avec additifs. Le produit détecte les fuites dans un court espace de temps, de forme sûre.  
Le produit est biodégradable, ininflammable. Il n'est ni vénéneux ni corrosif.

El Spray Detetor de Fugas P600 es un producto de elevada calidad con base acuosa y aditivos.  
Este producto detecta fugas en un corto espacio de tiempo, de una forma segura. El producto es biodegradable. No es inflamable, ni venenoso ni corrosivo.

CÓDIGO CODE / CODE / CÓDIGO	CAPACIDADE CAPACITY / CAPACITÉ / CAPACIDAD	EMBALAGEM QUANTITY / EMBALLAGE / EMBALAJE	QTD. PALETTE PALET / QT. PALETTE / CANT. PALÉ
001060000001	400 ml	6	576

## Spray Contactos Eléctricos P170

P170 Electrical Contacts Spray / Spray contacts électriques P170 / Spray para Contactos Eléctricos P170

O Spray para Contactos Eléctricos, é um produto de elevada qualidade, ideal para a limpeza e restabelecimento dos contactos de circuitos eléctricos e eletrónicos. Produto com base em solventes de evaporação rápida, indicado para a limpeza e proteção de contactos eléctricos. Mantém os contactos eléctricos, livres da oxidação. Remove eficazmente gordura, poeiras e sujidade, sem deixar resíduos, restabelecendo a passagem de corrente. Não é condutor de corrente eléctrica.



Dados técnicos e ficha de segurança disponível sob pedido.

/ Technical information and safety data sheet available under request / Données techniques et fiche de sécurité disponible sur demande / Datos técnicos y ficha de seguridad disponible bajo pedido  
dep.technico@pecol.pt



Spray for Electronic Contacts, is a high quality product, ideal for cleaning and restoration of contacts of electrical and electronic circuits. Product based on fast evaporating solvents suitable for the cleaning and protection of electrical contacts. Keeps the electric contacts free of oxidation. Removes grease, dust and dirt effectively leaving no residues, restoring the current flow. Not electric conductor.

Le spray pour contacts électroniques est un produit de haute qualité, parfait pour le nettoyage et la restitution des contacts électriques en circuits électriques et électroniques. Produit à base de solvants d'évaporation rapide ce produit est approprié pour le nettoyage et protection des contacts électriques. Maintient les circuits électriques libres d'oxydation. Élimine complètement la graisse, la poussière et la saleté sans laisser traces de façon à rétablir le passage du courant. Le spray P170 n'est pas un conducteur de courant électrique.

El Spray para Contactos Eléctricos, es un producto de alta calidad, ideal para la limpieza y restauración de los contactos de los circuitos eléctricos y electrónicos. Producto con base de disolventes de evaporación rápida, indicado para la limpieza y protección de los contactos eléctricos. Mantiene los contactos eléctricos libres de oxidación. Elimina eficazmente la grasa, el polvo y suciedad sin dejar residuos, restaurando el paso de corriente. No es conductor de la corriente eléctrica.

CÓDIGO CODE / CODE / CÓDIGO	CAPACIDAD CAPACITY / CAPACITÉ / CAPACIDAD	EMBALAJE QUANTITY / EMBALLAGE / EMBALAJE	CANT. PALÉ PALET / QT. PALETTE / QTD. PALETTE
001017000000	400 ml	6	576



# Spray Cola P900

Adhesive Spray P900 / Spray Colle P900 / Spray Adhesivo P900



Cola de excelente qualidade e secagem rápida para adesões temporárias ou permanentes. Ideal para utilizar em superfícies de papel, cartão, cortiça, madeira, têxtil, couro e vários plásticos.



Dados técnicos e ficha de segurança disponível sob pedido.

/ Technical information and safety data sheet available under request / Données techniques et fiche de sécurité disponible sur demande / Datos técnicos y ficha de seguridad disponible bajo pedido  
dep.tecnico@pecol.pt

High quality glue for both permanent and temporary adhesion. Suitable to glue paper, cardboard, wood, textile and various types of plastic. Ideal to be used in large surfaces of paper, cardboard, cork, wood, textile, leather and various plastics.

Colle d'excellente qualité et séchage rapide pour adhésion temporaires ou permanentes. Idéale pour utiliser en surfaces en papier, carton, liège, bois, textile, cuir et plusieurs plastiques.

Adhesivo de excelente calidad y secado rápido para adhesiones temporales o permanentes. Ideal para utilizar en superficies de papel, cartón, corcho, madera, textil, cuero y varios plásticos.

CÓDIGO CODE / CODE / CÓDIGO	CAPACIDAD CAPACITY / CAPACITÉ / CAPACIDADE	EMBALAJE QUANTITY / EMBALLAGE / EMBALAGEM	CANT. PALÉ PALET / QT. PALETTE / QTD. PALETTE
001090000001	400 ml	6	576







# Spray Zinco Claro P10 Premium

Zinc Spray Coating Bright Colour P10 Premium / Spray Zinc Clair P10 Premium / Spray Zinc Claro P10 Premium

O Spray de Zinco Claro é um protetor anticorrosivo, de secagem rápida e boa aderência em todas as superfícies metálicas. O produto depois de seco apresenta uma cor cinzenta clara idêntica à das peças galvanizadas, devido aos pigmentos de zinco (98% de pureza) e de alumínio.

O Spray Zinco pode ser usado como primário anticorrosivo e pode ser pintado depois de seco por uma grande variedade de tintas.

Resistente até +500°C.



Dados técnicos e ficha de segurança disponível sob pedido.

/ Technical information and safety data sheet available under request / Données techniques et fiche de sécurité disponible sur demande / Datos técnicos y ficha de seguridad disponible bajo pedido

dep.technico@pecol.pt



Zinc Spray Coating Bright Colour is an anti corrosive primer that adheres to any metal surface. It is a semi-glossy silvertone paint which gives a very good electrochemical corrosion protection on metal, by means of the pure zinc contents (98% pure and 23% w/w in dry film) and the aluminum pigments. It can be used as a primer or as a one can system on metal and it can be painted over with a wide range of various paints. Resist to temperatures up to +550°C.

Le Spray Zinc Clair est un protecteur anticorrosif, à séchage rapide et bonne adhérence sur toutes surfaces métalliques. Le produit séché présente une couleur gris clair semblable à des pièces galvanisées, en raison du pigment de zinc (98% de pureté) et de l'aluminium.

Le Spray Zinc peut être utilisé comme primaire anticorrosion et peut être peint après le séchage par une grande variété de peintures. Résistante jusqu'à +550°C.

El Spray Zinc Claro es un protector anticorrosivo, de secado rápido y buena adherencia en todas las superficies metálicas. El producto una vez seco presenta un color gris claro idéntico a las piezas galvanizadas, debido a los pigmentos de zinc (98% de pureza) y de aluminio. El Spray Zinc puede ser usado como imprimación anticorrosiva y puede ser pintado una vez seco con una gran variedad de pinturas. Resistente hasta +550°C.

CÓDIGO CODE / CODE / CÓDIGO	CAPACIDADE CAPACITY / CAPACITÉ / CAPACIDAD	EMBALAGEM QUANTITY / EMBALLAGE / EMBALAJE	QTD. PALETE PALET / QT. PALETTE / CANT. PALÉ
001010000000	400 ml	12	576

# Spray Zinco Brilhante P15 Special

Zinc Spray Coating Bright Colour P15 Special / Spray Zinc Brillant P15 Special / Spray Zinc Brillante P15 Special

O Spray de Zinco P15 proporciona uma camada protetora e duradoura, tendo uma elevada capacidade de cobertura. Confere a todo o tipo de superfícies metálicas (em bruto, polido, furado ou soldado) uma resistência a agentes atmosféricos, marítimos e água salgada.



Dados técnicos e ficha de segurança disponível sob pedido.

/ Technical information and safety data sheet available under request / Données techniques et fiche de sécurité disponible sur demande / Datos técnicos y ficha de seguridad disponible bajo pedido

dep.technico@pecol.pt



P15 is a protective coat with high covering power and long life, making all metallic surface (rough, polished, punctured, soldered) resistant to atmospheric agents, marine and salt water.

Le Spray de Zinc P15 proportionne une couche protectrice et durable, ayant une haute capacité de couverture. Confère à tous les types de surfaces métalliques (en brut, poli, percé ou soudé) une résistance anticorrosive aux agents atmosphériques, maritimes et eau salée.

El Spray de Zinc P15 proporciona una capa protectora y duradera, teniendo una elevada capacidad de cobertura. Proporciona a todo tipo de superficies metálicas (en bruto, pulido, perforado o soldado) una resistencia a agentes atmosféricos, marítimos y agua salada.

CÓDIGO CODE / CODE / CÓDIGO	CAPACIDADE CAPACITY / CAPACITÉ / CAPACIDAD	EMBALAGEM QUANTITY / EMBALLAGE / EMBALAJE	QTD. PALETE PALET / QT. PALETTE / CANT. PALÉ
001001500000	400 ml	12	576



# Spray Zinco Escuro P20 Premium

Zinc Spray Coating Dark Colour P20 Premium / Spray Zinc Foncé P20 Premium / Spray Zinc Oscuro P20 Premium



O Spray de Zinco Escuro é um primário anticorrosivo de excepcional qualidade que garante uma galvanização a frio apropriada para todas as superfícies metálicas. Proporciona uma coloração cinza escuro às superfícies metálicas devido à sua elevada percentagem de pigmentos de zinco na camada seca.



**Dados técnicos e ficha de segurança disponível sob pedido.**

/ Technical information and safety data sheet available under request / Données techniques et fiche de sécurité disponible sur demande / Datos técnicos y ficha de seguridad disponible bajo pedido  
dep.tecnico@pecol.pt

Zinc Spray Coating Dark Colour is an anti corrosive primer that adheres to any metal surface, forming a long-lasting protective film, preventing from oxidation and corrosion. It gives a dark colour to the treated surface. Due to its high zinc content in the dry film, it builds up a tough film with excellent anti-corrosion properties.

Le Spray de Zinc Foncé est un primaire anticorrosif de qualité exceptionnelle qui garantit une galvanisation à froid appropriée à toutes les surfaces métalliques. Il proportionne une coloration gris foncé aux surfaces métalliques dû à son pourcentage élevé de pigments de zinc dans la couche sèche.

El Spray de Zinc Oscuro es un recubrimiento anticorrosivo de excepcional calidad que garantiza una galvanización en frío apropiada para todas las superficies metálicas. Proporciona una coloración gris oscura a las superficies metálicas debido a su elevado porcentaje de pigmentos de zinc en la capa seca.

CÓDIGO CODE / CODE / CÓDIGO	CAPACIDADE CAPACITY / CAPACITÉ / CAPACIDAD	EMBALAGEM QUANTITY / EMBALLAGE / EMBALAJE	QTD. PALETE PALET / QT. PALETTE / CANT. PALÉ
00102000000	400 ml	12	576

# Spray Zinco Mate P25 Special

Zinc Spray Coating Dark Colour P25 Special / Spray Zinc Mate P25 Special / Spray Zinc Mate P25 Special



O Spray de Zinco P25 é um spray anti corrosivo com elevada capacidade de cobertura, formando um duradoura película protetora que protege todas as superfícies metálicas de agentes atmosféricos. Este produto confere uma cor escura à superfície tratada.



**Dados técnicos e ficha de segurança disponível sob pedido.**

/ Technical information and safety data sheet available under request / Données techniques et fiche de sécurité disponible sur demande / Datos técnicos y ficha de seguridad disponible bajo pedido  
dep.tecnico@pecol.pt

P25 is a anti corrosive primer with high coverage properties, forming a long lasting protective film, making all metallic surfaces resistant to atmospheric agents. It gives a dark colour to the treated surface.

Le Spray de Zinc P25 est un spray anticorrosif avec une grande capacité de couverture, formant une pellicule protectrice durable qui protège toutes les surfaces métalliques des agents atmosphériques. Le produit confère une couleur foncée à la surface traité.

El Spray de Zinc P25 es un spray anticorrosivo con elevada capacidad de cobertura, actúa formando una duradera película protectora que protege todas las superficies metálicas de agentes atmosféricos. Este producto proporciona un color oscuro a la superficie tratada.

CÓDIGO CODE / CODE / CÓDIGO	CAPACIDADE CAPACITY / CAPACITÉ / CAPACIDAD	EMBALAGEM QUANTITY / EMBALLAGE / EMBALAJE	QTD. PALETE PALET / QT. PALETTE / CANT. PALÉ
00100250000	400 ml	12	576



# Spray Inox P30 Premium

Stainless Steel Spray P30 Premium / Spray Inox P30 Premium / Spray Inox P30 Premium

O Spray de Inox P30 tem um grande poder anticorrosivo e proporciona um acabamento na superfície com grande resistência à intempérie, devido à sua elevada resistência química. Pode ser utilizado sempre que seja necessária uma proteção efetiva e resistente.

A liga é composta por cromo, níquel e manganésio.

A cor do Spray após a cura é muito semelhante à cor do Aço Inox.



Dados técnicos e ficha de segurança disponível sob pedido.

/ Technical information and safety data sheet available under request / Données techniques et fiche de sécurité disponible sur demande / Datos técnicos y ficha de seguridad disponible bajo pedido

dep.tecnico@pecol.pt



*Pecol Stainless Steel Spray is a high quality corrosion and weather resistant surface coating. Due to the high chemical resistance, it can be used wherever a resistant, effective protective layer is required. The alloy is composed of chromium, nickel and manganese. The color of the product after dry is identical to the stainless steel.*

*Le Spray Inox P30 a un grand pouvoir anticorrosif et proportionne une finition sur la surface avec une grande résistance aux intempéries, dû à sa résistance chimique élevée. Peut être utilisé à chaque fois qu'une protection effective et résistante est nécessaire. L'alliage est composé de chrome, nickel et magnésium. La couleur du spray après séchage est semblable à celle de l'inox.*

*El Spray de Inox P30 tiene un gran poder anticorrosivo y proporciona un acabado en la superficie con gran resistencia a la intemperie, debido a su elevada resistencia química. Puede ser utilizado siempre que sea necesaria una protección efectiva y resistente. La aleación está compuesta por cromo, níquel y manganeso. El color del Spray tras la cura es muy similar al color del Acero Inox.*

CÓDIGO CODE / CODE / CÓDIGO	CAPACIDADE CAPACITY / CAPACITÉ / CAPACIDAD	EMBALAGEM QUANTITY / EMBALLAGE / EMBALAJE	QTD. PALETTE PALET / QT. PALETTE / CANT. PALÉ
001030000000	400 ml	6	576

# Spray Alumínio P40 Premium

Aluminium Spray P40 Premium / Spray Aluminium P40 Premium / Spray Aluminio P40 Premium

O Spray de Alumínio P40 é um primário para tratar superfícies de alumínio, metal, madeira, vidro, pedra e diversos tipos de plásticos.

O Spray de Alumínio P40 oferece um grande poder anticorrosivo em todas as superfícies metálicas e é resistente a diversos ácidos diluídos e lixívia, assim como à intempérie.

O produto tem um excelente poder de cobertura e adesão e proporciona um brilho metálico à superfície.



Dados técnicos e ficha de segurança disponível sob pedido.

/ Technical information and safety data sheet available under request / Données techniques et fiche de sécurité disponible sur demande / Datos técnicos y ficha de seguridad disponible bajo pedido

dep.tecnico@pecol.pt



*P40 is a high quality decorative lacquer to treat surfaces of aluminium, metal, wood, glass, stone and various types of plastic.*

*P40 is offers a high quality corrosion protection for all metallic surfaces and is resistant against many diluted acids and lye, as well as atmospheric influences. The product has an excellent coverage and adhesion and gives a metallic gloss to the surface.*

*Le Spray Aluminium P40 est un primaire pour traiter les surfaces en aluminium, métal, bois, verre, pierre et divers types de plastiques.*

*Le Spray Aluminium P40 offre un grand pouvoir anticorrosif sur toutes les surfaces métalliques et résiste à divers acides dilués et javel, ainsi qu'aux intempéries.*

*Le produit a un excellent pouvoir de couverture et d'adhésion et proportionne un éclat métallique à la surface.*

*El Spray de Aluminio P40 es un primario para tratar superficies de aluminio, metal, madera, vidrio, piedra y diversos tipos de plásticos.*

*El Spray de Aluminio P40 ofrece un gran poder anticorrosivo en todas las superficies metálicas y es resistente a diversos ácidos diluidos y lejías, así como a la intemperie.*

*El producto tiene un excelente poder de cobertura y adhesión y proporciona un brillo metálico a la superficie.*

CÓDIGO CODE / CODE / CÓDIGO	CAPACIDADE CAPACITY / CAPACITÉ / CAPACIDAD	EMBALAGEM QUANTITY / EMBALLAGE / EMBALAJE	QTD. PALETTE PALET / QT. PALETTE / CANT. PALÉ
001040000000	400 ml	6	576



# SPRAYS

Sprays / Sprays / Sprays

## Spray Lacagem P500 e Pincel de Retoque

Spray for Lacquered Aluminium P500 And Touch Up Pencil / Spray Laquage P500 et Pinceau de Retouche / Spray Lacado P500 y Pincel de Retoque



O Spray de Lacagem P500 e o Pincel de Retoque são um produto de elevada qualidade utilizando resinas de base acrílica. Este produto tem como principal função pintar variadas superfícies, tais como alumínio tratado ou não, metais, vidros, madeiras, pedras e vários tipos de plásticos. Este é o produto ideal para eliminar riscos dos perfis de alumínio lacados, utilizados nas janelas e portas. Proporciona um acabamento perfeito, idêntico à cor original da superfície. Pode ser aplicado tanto em interiores como em exteriores.



Dados técnicos e ficha de segurança disponível sob pedido.  
/ Technical information and safety data sheet available under request / Données techniques et fiche de sécurité disponible sur demande / Datos técnicos y ficha de seguridad disponible bajo pedido  
dep.tecnico@pecol.pt

The high quality acrylic decorative lacquer P500 and the touch up pencil are used to treat surfaces, treated and untreated of aluminium, metal, glass, wood, stone and various types of plastics. This is the ideal product to eliminate scratches from lacquered aluminium profiles used on windows and doors. The product leaves a perfect finishing similar to the original color of the surface. Can be used in interiors and outdoors applications.

Le Spray de Laquage P500 et Le Pinceau de Retouche est un produit de grande qualité utilisant des résines de base acrylique. Le produit a comme principale fonction peindre plusieurs surfaces, tels que les aluminiums traités ou non, métaux, verres, bois, pierres et plusieurs types de plastiques. Le produit est idéal pour éliminer les rayures des profilés en aluminium laqués, utilisés dans les fenêtres et portes. Le produit proportionne une finition parfaite, identique à la couleur original de la surface. Peut être appliqué aussi bien en intérieurs qu'en extérieurs.

El Spray de Lacado P500 y el Pincel de Retoque es un producto de elevada calidad, compuesto con resinas de base acrílica. Este producto tiene como principal función pintar superficies variadas, tales como aluminios tratados o no, metales, vidrios, maderas, piedras y varios tipos de plásticos. Este producto es el ideal para eliminar arañazos de los perfiles de aluminio lacados, utilizados en ventanas y puertas. El producto de proporciona un acabado perfecto, idéntico al color original de la superficie. Puede ser aplicado tanto en interiores como en exteriores.

COR COLOR / COULEUR / COLOR	RAL
Branco / Signal white / Blanc de sécurité / Blanco señales	9003
Branco puro / Pure white / Blanc pur / Blanco puro	9010
Branco opaco / Pure white Matte / Blanc Dépoli / Blanco mate	9110
Cinza / Dusty grey / Gris poussière / Gris polvo	7037
Cinza ferro / Iron grey / Gris fer / Gris hierro	7011
Verde musgo / Moss green / Vert mousse / Verde musgo	6005
Verde / Fir green / Vert sapin / Verde abeto	6009
Castanho / Sepia brown / Brun sépia / Sepia	8014
Preto / Jet black / Noir foncé / Negro intenso	9005

SPRAYP500 / SPRAY P500 / SPRAY P500 / SPRAY P500		
CÓDIGO CODE / CODE / CÓDIGO	CAPACIDADE CAPACITY / CAPACITÉ / CAPACIDAD	EMBALAGEM QUANTITY / EMBALLAGE / EMBALAJE
00105000001	400 ml	6
00105000002	400 ml	6
00105000009	400 ml	6
00105000006	400 ml	6
00105000005	400 ml	6
00105000003	400 ml	6
00105000004	400 ml	6
00105000008	400 ml	6
00105000007	400 ml	6

PINCEL DE RETOQUE / TOUCH UP PENCIL / PINCEAU DE RETOUCHE / PINCEL DE RETOQUE		
CÓDIGO CODE / CODE / CÓDIGO	CAPACIDADE CAPACITY / CAPACITÉ / CAPACIDAD	EMBALAGEM QUANTITY / EMBALLAGE / EMBALAJE
-	-	-
001490100000	12 ml	6
001491100000	12 ml	6
001470370000	12 ml	6
001470110000	12 ml	6
001460050000	12 ml	6
001462000000	12 ml	6
001480140000	12 ml	6
001490050000	12 ml	6





# Spray Tinta Acrílica

Acrylic Enamel Spray / Spray Peinture Acrylique / Spray Pintura Acrílica

O spray de tinta acrílica foi concebido para garantir uma cobertura de qualidade superior e com um acabamento magnífico, de secagem rápida, adequado para interiores e para exteriores.

Este produto pode ser aplicado numa vasta gama de superfícies, tais como metal, madeira, plástico e vidro, resistindo a riscos e ao envelhecimento.

Gama completa de cores para abranger todo o tipo de aplicações, industriais e domésticas.



Dados técnicos e ficha de segurança disponível sob pedido.

/ Technical information and safety data sheet available under request / Données techniques et fiche de sécurité disponible sur demande / Datos técnicos y ficha de seguridad disponible bajo pedido

dep.tecnico@pecol.pt

Is a premium acrylic enamel, designed to provide superior coverage with excellent finish and quick drying, suitable for indoor/outdoor use. Adhesive to a wide range of surfaces: metal, wood, plastic, glass, resists to the aging and scratching. Complete colours range to suit all market needs for industry, house and DIY.

Le spray de peinture acrylique a été conçu pour garantir une couverture de qualité supérieur et une finition magnifique, de séchage rapide, adéquate pour intérieurs et extérieurs.

Le produit peut être appliqué sur une vaste gamme de surfaces, telles que le métal, bois, plastique et verre, résistant aux rayures et vieillissement. Gamme complète de couleurs pour englober tous types d'applications, industrielles et domestiques.

El Spray de Pintura Acrílica fue desarrollado para garantizar una cobertura de calidad superior y con un acabado magnífico, de secado rápido, adecuado para interiores y exteriores.

Este producto puede ser aplicado en una amplia gama de superficies, tales como metal, madera, plástico y vidrio, resistiendo a arañazos y al envejecimiento. Gama completa de colores para abarcar todo tipo de aplicaciones, industriales y domésticas.

CÓDIGO CODE / CODE / CÓDIGO	COR COLOR / COULEUR / COLOR	RAL	CAPACIDADE CAPACITY / CAPACITÉ / CAPACIDAD	EMBALAGEM QUANTITY / EMBALLAGE / EMBALAJE	QTD. PALETTE PALET / QT. PALETTE / CANT. PALÉ
00104000001	Transp. opaco / Transparent matte / Transparent opaque / Transparente opaco	-	400 ml	6	522
00104000002	Transp. brilhante / Transparent glossy / Transparent brilliant / Transparente brillante	-	400 ml	6	522
001040090100	Branco opaco / Pure white matte / Blanc dépoli / Blanco mate	9010M	400 ml	6	522
001040090101	Branco brilhante / Pure white gloss / Blanc brillant / Blanco brillante	9010G	400 ml	6	522
001040090051	Preto opaco / Jet black matte / Noir dépoli / Negro mate	9005M	400 ml	6	522
001040090050	Preto brilhante / Jet black gloss / Noir brillant / Negro brillante	9005G	400 ml	6	522
001040070240	Cinza grafite / Gris graphite / Graphite grey / Gris grafito	7024	400 ml	6	522
001040070010	Cinza prata / Silver grey / Gris argent / Gris plata	7001	400 ml	6	522
001040070400	Cinza / Window grey / Gris fenêtre / Gris Ventana	7040	400 ml	6	522
001040070350	Cinza luminoso / Light grey / Gris clair / Gris luminoso	7035	400 ml	6	522
001040070320	Cinza pedra / Pebble grey / Gris sílex / Gris guijarro	7032	400 ml	6	522
001040090060	Alumínio claro / White aluminium / Aluminium blanc / Aluminio blanco	9006	400 ml	6	522
001040060050	Verde musgo / Moss green / Vert mousse / Verde musgo	6005	400 ml	6	522
001040060260	Verde opala / Opal green / Vert opale / Verde opala	6026	400 ml	6	522
001040060020	Verde folha / Leaf green / Vert feuillage / Verde hoja	6002	400 ml	6	522
001040060290	Verde menta / Mint green / Vert menthe / Verde menta	6029	400 ml	6	522
001040060110	Verde cinza / Reseda green / Vert réséda / Verde reseda	6011	400 ml	6	522
001040050120	Azul luminoso / Light blue / Bleu clair / Azul luminoso	5012	400 ml	6	522
001040050050	Azul / Signal blue / Bleu de sécurité / Azul señales	5005	400 ml	6	522
001040050170	Azul tráfego / Traffic blue / Bleu clair / Azul tráfico	5017	400 ml	6	522
001040050100	Azul genciana / Gentian blue / Bleu gentiane / Azul genciana	5010	400 ml	6	522
001040050030	Azul safira / Sapphire blue / Blue saphir / Azul safiro	5003	400 ml	6	522
001040080110	Castanho noz / Nut brown / Brun noisette / Marrón nuez	8011	400 ml	6	522
001040080140	Castanho / Sepia brown / Brun sépia / Castanho / Sepia	8014	400 ml	6	522
001040080170	Castanho chocolate / Chocolate brown / Brun chocolat / Chocolate	8017	400 ml	6	522
001040030050	Bordeaux / Wine red / Rouge vin / Rojo vino	3005	400 ml	6	522
001040030090	Vermelho telha / Oxide red / Rouge oxyde / Rojo óxido	3009	400 ml	6	522
001040030000	Vermelho fogo / Flame red / Rouge feu / Rojo vivo	3000	400 ml	6	522
001040030200	Vermelho tráfego / Traffic red / Rouge signalization / Rojo tráfico	3020	400 ml	6	522
001040020040	Laranja puro / Pure orange / Orangé pur / Naranja puro	2004	400 ml	6	522
001040010070	Amarelo narciso / Daffodil yellow / Jaune narcissé / Amarillo narciso	1007	400 ml	6	522
001040010230	Amarelo tráfego / Traffic yellow / Jaune signalisation / Amarillo tráfico	1023	400 ml	6	522
001040010140	Marfim / Ivory / Ivoire / Marfil	1014	400 ml	6	522
001040010150	Crema / Light ivory / Ivoire clair / Marfil claro	1015	400 ml	6	522
001040010130	Pérola / Oyster white / Blanc perlé / Blanco perla	1013	400 ml	6	522
001040030150	Rosa claro / Light pink / Rose clair / Rosa claro	3015	400 ml	6	522
001040080040	Castanho Claro / Light brown / Brun clair / Marrón claro	8004	400 ml	6	522
001040070110	Cinza / Grey / Gris / Gris	7011	400 ml	6	522
001040070160	Cinza Escuro / Dark grey / Gris foncé / Gris oscuro	7016	400 ml	6	522
001040040100	Magenta / Magenta / Magenta / Magenta	4010	400 ml	6	522



# Spray Altas Temperaturas

High Temperature Enamel Spray / Spray Hautes Températures / Spray Altas Temperaturas



Spray de elevada qualidade, resistente a temperaturas até aos +800°C, que protege e reveste todo o tipo de objetos que estejam expostos a estas temperaturas.

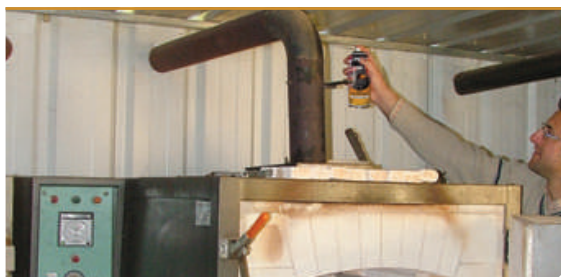

Dados técnicos e ficha de segurança disponível sob pedido.  
/ Technical information and safety data sheet available under request / Données techniques et fiche de sécurité disponible sur demande / Datos técnicos y ficha de seguridad disponible bajo pedido  
dep.tecnico@pecol.pt

Very high quality heat resistant (+800°C) enamel to coat and protect all objects exposed to heat.

Spray de haute qualité, résistant à des température jusqu'à +800°C, qui protège et revêt tous les types d'objets qui sont exposés à ces températures.

Spray de elevada calidad, resistente a temperaturas hasta los +800°C, que protege y reviste todo tipo de objetos que estén expuestos a estas temperaturas.

CÓDIGO CODE / CODE / CÓDIGO	COLOR COLOR / COULEUR / COR	RAL	CAPACIDADE CAPACITY / CAPACITÉ / CAPACIDAD	EMBALLAGEM QUANTITY / EMBALLAGE / EMBALAJE	QTD. PALETE PALET / QT. PALETTE / CANT. PALÉ
001004000001	Antracite / Anthracite / Anthracite / Antracita		400 ml	6	522
001004000000	Preto / Black / Noir / Negro		400 ml	6	522



A blue and silver drill bit stands vertically on a concrete floor. The floor is composed of large, light-colored tiles with visible grout lines and some surface wear. In the upper right corner, a green mat is partially visible. The drill bit is positioned centrally, with its tip pointing downwards.

# FERRAMENTAS DE CORTE

CUTTING TOOLS  
OUTILS DE COUPE  
HERRAMIENTAS DE CORTE



# CORTE

Cut / Coupe / Corte

## SDS PLUS BROCAS SDS PLUS

SDS Plus Hammer Drill / Foret à Marteau SDS Plus / Brocas SDS Plus

As brocas SDS Plus cumprem os standards de eficiência e performance, com uma rápida furação e com um mínimo de vibração. As Brocas SDS Plus são um excelente produto para uso profissional em betão, pedra natural, alvenaria... Ideal para usar em martelos a bateria e eletropneumáticos de 2 a 4 Kg com encaixe SDS Plus.

The SDS Plus Hammer drill, sets standards of efficiency and performance, with fast dynamic drilling progress and minimal vibrations, The SDS Plus drill bit is a powerful product for professional users in concrete, natural stone, masonry...  
For rotary hammer drills between 2 and 4 kg with SDS-plus chuck.

Les forets à marteau SDS Plus sont en accords avec les standards d'efficacité et de performance, avec un forage rapide et un minimum de vibration. Les forets à marteau SDS Plus Special sont un excellent produit pour usage professionnel en béton, pierre naturelle, maçonnerie...  
Pour utiliser sur marteau de 2 à 4 kg avec emboîtement SDS.

Las brocas SDS Plus cumplen los estándares de eficiencia y prestación, con una rápida perforación y con un mínimo de vibración. Las Brocas SDS Plus son un excelente producto para uso profesional en hormigón, piedra natural, mampostería...  
Para usar en taladros percutores de 2 a 4 Kg con inserción SDS Plus.



### PREMIUM



### SPECIAL



### CLASSIC





# SDS PLUS PREMIUM

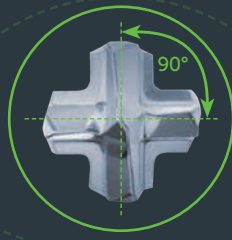
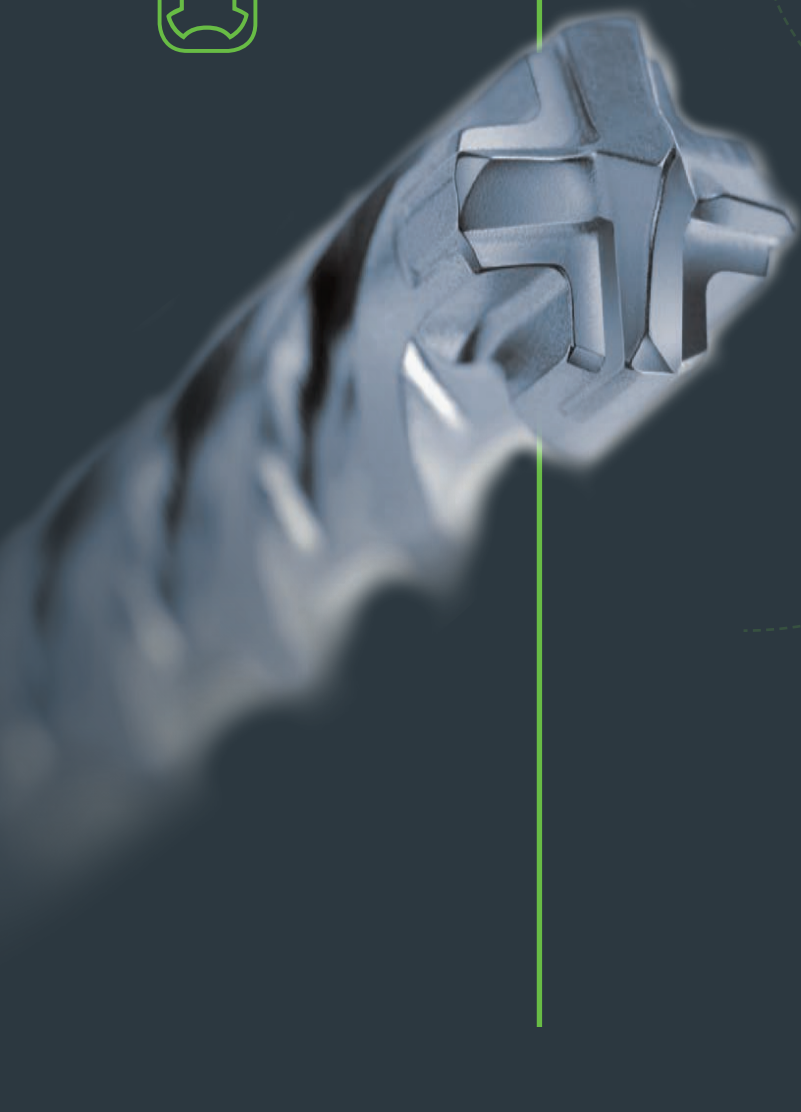

## CABEÇA DA BROCA DE CORPO ÚNICO

Em carboneto de tungsténio com 4 lâminas dispostas a 90° cuja simetria previne o sobredimensionamento do furo aquando do impacto nas barras de aço que podem ser encontradas no betão armado.

**ONE PIECE CARBIDE TIP**  
Element with optimal 4x90° solid carbide cutting symmetry prevents seizing up on hitting reinforcing steel.

**TÊTE DU FORET DE CORPS UNIQUE**  
En carbure de tungstène de 4 lames disposées à 90°, dont la symétrie empêche le surdimensionnement du trou lors de l'impact sur les barres en acier qui peuvent se trouver dans le béton armé.

**CABEÇA DE LA BROCA DE CUERPO ÚNICO**  
En carburo de tungsteno con 4 láminas dispuestas a 90° cuya simetría previene el sobredimensionamiento del agujero en el momento del impacto en las barras de acero que pueden ser encontradas en el hormigón armado.



## CHANFREADO DA CABEÇA

Que proporciona um tempo de vida maior da broca até 50%. Capacidade de furar otimizada e não desliza na presença de barras de aço.

**PATENTED REINFORCING CHAMFERING**  
Provides high longevity: up to +50%. Optimal drilling performance and no seizing up on hitting reinforcing steel.

**TÊTE CHANFREIN**  
Fournit une plus grande longévité au foret, jusqu'à 50%. Capacité de perçage optimisée et ne glisse pas dans la présence de barres d'acier.

**BISELADO DE LA CABEZA**  
Que proporciona un tiempo de vida mayor de la broca hasta 50%. Capacidad de perforar optimizada y no se desliza en la presencia de barras de acero.



## PONTA CENTRADORA

Para uma maior precisão no ataque ao material sem deslizamento. Com cabeça estriada, proporciona uma remoção rápida de poeiras e detritos.

**CENTERING POINT**  
For accurate drilling with no slipping. With the short head to flute entrance, it is capable of fast removal of drilling debris from drill head into the flute.

**POINTE DE CENTRAGE**  
Pour une précision plus élevée dans l'attaque du matériel sans glissement. La tête rayé proportionne une élimination rapide des poussières et des débris.

**PUNTA CENTRADORA**  
Para una mayor precisión en la perforación del material sin deslizamiento. Con cabeza estriada, proporciona una retirada rápida de polvo y residuos.



## GEOMETRIA DE 4 ESPIRAIS

Que assegura que a carga é uniformemente distribuída sobre todas as espirais reduzindo o seu desgaste.

**GENUINE 4 FLUTE GEOMETRY**  
Ensures that the load is fully distributed over all flutes creating low and uniform flute wear.

**GÉOMÉTRIE DE 4 SPIRAL**  
Cela garantit que la charge est répartie uniformément sur toutes les spirales réduisant l'usure.

**GEOMETRIA DE 4 ESPIRALES**  
Que asegura que la carga es uniformemente distribuida sobre todas las espirales reduciendo su desgaste.

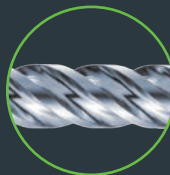

## REALIZAÇÃO DE FUROS RIGOROSAMENTE CILÍNDRICOS

E reduzida vibração durante a operação devido ao corpo de 4 espirais. Garante também uma remoção ótima do pó proveniente da furação.

**THE 4 FLUTED SPIRAL GEOMETRY**  
Ensures cylindrical drilling holes and low vibration drilling performance. Optimal removal of drilling dust due to the cutting flute geometry. The optimised flute core strength provides high fracture resistance.

**FAIRE DES TROUS STRICTEMENT CILINDRIQUES**  
Et réduire les vibrations pendant le fonctionnement grâce aux 4 spirales. Elle assure également l'élimination de poussières provenant du forage.

**REALIZACIÓN DE AGUJEROS RIGOROSAMENTE CILÍNDRICOS**  
Y reducida vibración durante la operación debido al cuerpo de 4 espirales. Garantiza también una retirada óptima del polvo proveniente del perforado.



## DE ACORDO COM PGM

Permite efetuar furos concêntricos para um encaixe perfeito da bucha.

**PGM CONFORMITY**  
Stands for precisely fitting anchor holes and precise concentricity.

**HOMOLOGATION PGM**  
Permet de faire des trous concentriques pour un ajustement parfait du foret.

**EN CONFORMIDAD CON PGM**  
Permite efectuar agujeros concéntricos para un encaje perfecto del taco.



## BAIXA VIBRAÇÃO

Proporciona uma perfuração suave e confortável, protegendo assim o operador e a máquina.

**LOW-VIBRATION DRILLING**  
Guarantees smooth drilling which protects man and machine.

**VIBRATION RÉDUITE**  
Foret SDS Plus Premium proportionne un forage doux et confortable, protégeant ainsi l'ouvrier et la machine.

**BAJA VIBRACIÓN**  
Proporciona una perforación suave y confortable, protegiendo así al operario y la máquina.



# CORTE

Cut / Coupe / Corte

## SDS PLUS

Premium / Premium / Premium / Premium



CÓDIGO CODE / CODE / CÓDIGO	DIMENSÕES SIZE / DIMENSIONS / MEDIDA	l	EMBALAGEM QUANTITY / EMBALLAGE / EMBALAJE
034150051100	05 x 110	50	1
034150051600	05 x 160	100	1
034150551000	05,5 x 160	100	1
034150061150	06 x 110	50	1
034150061650	06 x 160	100	1
034150062150	06 x 210	150	1
034150062650	06 x 260	200	1
034150651650	06,5 x 160	100	1
034150065210	06,5 x 210	150	1
034150071600	07 x 160	100	1
034150081100	08 x 110	50	1
034150081650	08 x 160	100	1
034150082150	08 x 210	150	1
034150082650	08 x 260	200	1



CÓDIGO CODE / CODE / CÓDIGO	DIMENSÕES SIZE / DIMENSIONS / MEDIDA	l	EMBALAGEM QUANTITY / EMBALLAGE / EMBALAJE
034150101600	010 x 160	100	1
034150102150	010 x 210	150	1
034150102650	010 x 260	200	1
034150103650	010 x 450	400	1
034150122150	012 x 210	150	1
034150122650	012 x 260	200	1
034150124650	012 x 450	400	1
034150142150	014 x 210	150	1
034150142650	014 x 260	200	1
034150143650	014 x 310	250	1
034150161600	016 x 160	100	1
034150162100	016 x 210	150	1
034150163100	016 x 310	250	1



**Especialmente adequada em materiais em que para além de perfuração também necessita percussão**

*Particularly suitable in materials that besides drilling also requires percussion*

*Particulièrement appropriée dans des matériaux en qu'outre le forage exige également la percussion*

*Especialmente adecuada en materiales donde además de perforación se necesita percusión*

## SDS PLUS

Special / Special / Special / Special

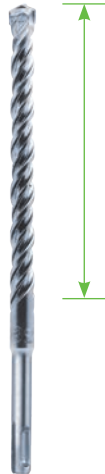

CÓDIGO CODE / CODE / CÓDIGO	DIMENSÕES SIZE / DIMENSIONS / MEDIDA	l	EMBALAGEM QUANTITY / EMBALLAGE / EMBALAJE
034121041100	04 x 110	50	1
034121041600	04 x 160	100	1
034121051100	05,0 x 110	50	1
034121551100	05,5 x 110	50	1
034121551600	05,5 x 160	100	1
034121061100	06,0 x 110	50	1
034121061600	06,0 x 160	100	1
034121062100	06,0 x 210	150	1
034121062600	06,0 x 260	200	1
034121651100	06,5 x 110	50	1
034121651600	06,5 x 160	100	1
034121071600	07 x 160	100	1
034121081100	08 x 110	50	1
034121081600	08 x 160	100	1
034121082100	08 x 210	150	1
034121091600	09 x 160	100	1
034121101600	010 x 160	100	1
034121102100	010 x 210	150	1
034121102600	010 x 260	200	1



CÓDIGO CODE / CODE / CÓDIGO	DIMENSÕES SIZE / DIMENSIONS / MEDIDA	l	EMBALAGEM QUANTITY / EMBALLAGE / EMBALAJE
034121121600	012 x 160	110	1
034121122600	012 x 260	210	1
034121123600	012 x 360	310	1
034121141600	014 x 160	110	1
034121142100	014 x 210	160	1
034121142600	014 x 260	210	1
034121162100	016 x 210	160	1
034121163100	016 x 310	260	1
034121182000	018 x 200	150	1
034121182500	018 x 250	200	1
034121183000	018 x 300	250	1
034121202000	020 x 200	150	1
034121203000	020 x 300	250	1
034121204500	020 x 450	400	1
034121224500	022 x 450	-	1
034121244500	024 x 450	-	1
034121264500	026 x 450	-	1



**Especialmente adequada em materiais em que para além de perfuração também necessita percussão**

*Particularly suitable in materials that besides drilling also requires percussion*

*Particulièrement appropriée dans des matériaux en qu'outre le forage exige également la percussion*

*Especialmente adecuada en materiales donde además de perforación se necesita percusión*

## SDS PLUS

Classic / Classic / Classic / Classic

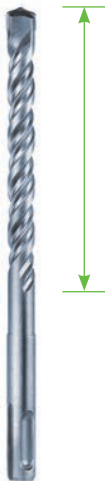

CÓDIGO CODE / CODE / CÓDIGO	DIMENSÕES SIZE / DIMENSIONS / MEDIDA	l	EMBALAGEM QUANTITY / EMBALLAGE / EMBALAJE
034021041100	04 x 110	50	1
034021041600	04 x 160	100	1
034021051100	05 x 110	50	1
034021551100	05,5 x 110	50	1
034021551600	05,5 x 160	100	1
034021061100	06 x 110	50	1
034021061600	06 x 160	100	1
034021062100	06 x 210	150	1
034021062600	06 x 260	200	1
034021651100	06,5 x 110	50	1
034021651600	06,5 x 160	100	1
034021071600	07 x 160	100	1
034021081100	08 x 110	50	1
034021081600	08 x 160	100	1
034021082100	08 x 210	150	1
034021091600	09 x 160	100	1
034021101600	010 x 160	100	1
034021102100	010 x 210	150	1

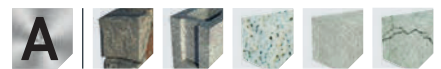

CÓDIGO CODE / CODE / CÓDIGO	DIMENSÕES SIZE / DIMENSIONS / MEDIDA	l	EMBALAGEM QUANTITY / EMBALLAGE / EMBALAJE
034021102600	010 x 260	200	1
034021121600	012 x 160	110	1
034021122600	012 x 260	210	1
034021123600	012 x 360	310	1
034021141600	014 x 160	110	1
034021142100	014 x 210	160	1
034021142600	014 x 260	210	1
034021161600	016 x 160	110	1
034021162100	016 x 210	160	1
034021162600	016 x 260	210	1
034021163100	016 x 310	260	1
034021182000	018 x 200	150	1
034021182500	018 x 250	200	1
034021183000	018 x 300	250	1
034021202000	020 x 200	150	1
034021203000	020 x 300	250	1
034021204500	020 x 450	400	1



**Especialmente adequada em materiais em que para além de perfuração também necessita percussão**

*Particularly suitable in materials that besides drilling also requires percussion*

*Particulièrement appropriée dans des matériaux en qu'outre le forage exige également la percussion*

*Especialmente adecuada en materiales donde además de perforación se necesita percusión*



## Conjuntos Brocas SDS PLUS

SDS Plus Assortments / Jeu de Forets SDS Plus / Conjunto de Brocas SDS Plus

# SDS PLUS

### Conjunto 7 Brocas SDS PLUS

/ Set of 7 SDS Plus Drills / Jeu de 7 Forets SDS Plus / Conjunto de 7 Brocas SDS Plus



### Conjunto 5 Brocas SDS PLUS

/ Set of 5 SDS Plus Drills / Jeu de 5 Forets SDS Plus / Conjunto de 5 Brocas SDS Plus



### Conjunto 7 Brocas SDS PLUS

/ Set of 7 SDS Plus Drills / Jeu de 7 Forets SDS Plus / Conjunto de 7 Brocas SDS Plus



**DIMENSÕES**  
SIZE / DIMENSIONS / MEDIDA  
5-110 | 6-110 | 8-110  
| 6-160 | 8-160 | 10-160 | 12-160

**CÓDIGO**  
CODE / CODE /  
CÓDIGO

**EMBALAGEM**  
QUANTITY /  
EMBALLAGE /  
EMBALAJE

CLASSIC 03422100001 1

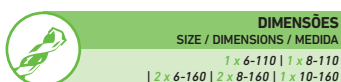

**DIMENSÕES**  
SIZE / DIMENSIONS / MEDIDA  
1 x 6-110 | 1 x 8-110  
| 2 x 6-160 | 2 x 8-160 | 1 x 10-160

**CÓDIGO**  
CODE / CODE /  
CÓDIGO

**EMBALAGEM**  
QUANTITY /  
EMBALLAGE /  
EMBALAJE

PREMIUM 03422200001 1  
SPECIAL 03422200002 1  
CLASSIC 03422200003 1



**DIMENSÕES**  
SIZE / DIMENSIONS / MEDIDA  
1 x 6-110 | 1 x 8-110  
| 1 x 6-160 | 1 x 8-160 | 1 x 10-160

**CÓDIGO**  
CODE / CODE /  
CÓDIGO

**EMBALAGEM**  
QUANTITY /  
EMBALLAGE /  
EMBALAJE

PREMIUM 03422300001 1  
SPECIAL 03422300002 1  
CLASSIC 03422300003 1

## Guilhos SDS Plus

Chisels SDS Plus Shank / Burins SDS Plus / Cinceles SDS Plus

# SDS PLUS



#### 1. Ponteiro

/ Pointed chisel  
/ Pointerolle / Puntero



#### Perfuração inicial de lajes de betão e demolição

Starts holes in concrete slabs, general chipping and breaking  
Perforage initial de dalles en béton et démolition  
Perforación inicial de losa de hormigón y demolición

#### 2. Liso

/ Flat chisel  
/ Plat / Plano



#### Para demolição e cinzelagem geral de tijolo, betão e pedra, para aplicações normais de passagem de cabos

For general chiseling and breaking work in brickwork, concrete and loose stone, for example when laying cables  
Pour démolition et cisèlement général de brique, béton et pierre, pour applications normales de passage de câbles  
Para demolición y cincelado general de ladrillo, hormigón y piedra, para aplicaciones normales de paso de cables



#### 3. Pá Larga

/ Spade chisel  
/ Bêche / Pala ancha

#### Para a remoção de grandes quantidades de materiais

For removing large quantities of materials  
Pour le retrait de grandes quantités de matériaux  
Para la eliminación de grandes cantidades de materiales



#### 4. Goiva

/ Hollow chisel  
/ Gouge / Huevo

#### Para abertura de canais estreitos em betão

For cutting narrow channels into concrete  
Pour ouverture de voies étroites en béton  
Para apertura de canales estrechos en hormigón



**CÓDIGO**  
CODE / CODE /  
CÓDIGO

**COMPRIMENTO**  
LENGTH  
/ LONGUEUR  
/ LONGITUD

**LARGURA**  
WIDTH  
/ LARGEUR  
/ LARGO

**EMBALAGEM**  
QUANTITY  
/ EMBALLAGE  
/ EMBALAJE

1	034921002500	250	-	1
2	034921202500	250	20	1
3	034921402500	250	40	1
4	034921222500	250	22	1



# CORTE

Cut / Coupe / Corte

## SDS MAX

### Brocas SDS Max Premium

SDS Max Hammer Drill Premium / Foret SDS Max Premium / Broca SDS Max Premium

A Broca SDS Max Premium é uma broca robusta, que permite uma furação agressiva devido à combinação da geometria da cabeça inovadora e a geometria da espiral, conferindo uma qualidade inigualável. Isto reflete-se no tempo de vida útil mais longo, em furos mais precisos e na transmissão de energia máxima do martelo para o substrato a furar. Uma ferramenta de alta qualidade para todos os operadores profissionais onde é necessário perfurar em betão reforçado e pedra natural.

Cabeça extremamente inovadora com ponta centradora e até 50% mais de carboneto de tungsténio para a perfuração precisa e furos concêntricos. Cortantes com uma geometria simétrica 4 x 90° garantindo furos perfeitamente concêntricos.

*Rotary hammer drill bit Premium is a robust, aggressive power pack, combining an innovative head geometry and an established flute geometry with uncompromising quality in its detail. This is reflected in the long service life, in the precise drill holes and in the maximal energy transmission. A high quality tool for all professional operators where to drill into reinforced concrete and natural stone is required.*

*Innovative drill bit head with centering point and up to 50% more carbide tip for precise drilling and optimal drill hole guidance. Symmetrical 4 x 90° solid carbide cutting geometry ensures perfect round drilling holes.*

*Le Foret SDS Max Premium est un foret robuste, qui permet le perçage agressif dû à une combinaison de la géométrie de la tête innovatrice et la géométrie en spirale, attribuant une qualité inégalable. Cela se traduit par la durée de vie plus longue, dans des trous plus précis et dans transmission d'énergie maximale du marteau pour le support à percer. Un outil de haute qualité pour tous les opérateurs professionnels où il est nécessaire percer le béton armé et la pierre naturelle.*

*Tête extrêmement innovatrice avec pointe de centrage et jusqu'à 50% de plus de carbure de tungstène pour une perforation précise et trous concentriques. Taillants avec une géométrie symétrique 4 x 90° garantissant un trou parfaitement centré.*

*La broca SDS Max Premium es una broca robusta, que permite una perforación agresiva debido a la combinación de la geometría de la cabeza innovadora y la geometría de la espiral, confiriendo una calidad inigualable. Esto se refleja en un tiempo de vida útil más largo, en agujeros más precisos y en la transmisión de energía máxima del martillo para el sustrato a perforar. Una herramienta de alta calidad para todos los utilizadores profesionales donde es necesario perforar en hormigón reforzado y piedra natural.*

*Cabeza extremadamente innovadora con punta centradora y hasta 50% más de carburo de tungsteno para la perforación precisa y agujeros concéntricos. Cortantes con una geometría simétrica 4 x 90° garantizando agujeros perfectamente concéntricos.*



#### PREMIUM

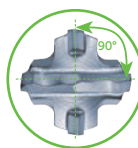

#### CORTANTES EM CARBONETO DE TUNGSTÉNIO COM UMA GEOMETRIA SIMÉTRICA 4 X 90°

Previne o sobredimensionamento do furo aquando da furação de betão reforçado.

#### CORTANTES SECUNDÁRIOS DE GRANDE DIMENSÃO E ROBUSTOS

Com cortantes curvados auxiliam o cortante central durante o processo de corte.

*OPTIMAL 4x90° CARBIDE CUTTING EDGE SYMMETRY*

*Prevents sizing up on hitting reinforcing steel.*

*LARGE, ROBUST SECONDARY CUTTERS*

*With dynamically curved cutting tips actively support the main carbide tip during fast drilling.*

*TAILLANTS EN CARBURE DE TUNGSTÈNE AVEC UNE GÉOMÉTRIE SYMÉTRIQUE 4 X 90°*

*Prévient la surchauffe du trou au moment du perçage du béton armé.*

*TALLANTS SECUNDARIOS DE GRANDE DIMENSION E ROBUSTOS*

*Avec taillants courbés qui aident le taillant central pendant le processus de coupe.*

*CORTANTES EN CARBURO DE TUNGSTENO CON UNA GEOMETRÍA SIMÉTRICA 4 X 90°*

*Previne el sobredimensionamiento del agujero en el momento de la perforación de hormigón reforzado.*

*CORTANTES SECUNDARIOS DE GRAN DIMENSION Y ROBUSTOS*

*Con cortantes curvados ayudan el cortante central durante el proceso de corte.*



#### MARCADOR DO DESGASTE DA BROCA

É um indicador para avaliar a estabilidade dimensional dos furos.

*THE WEAR MARKING*

*Is an indicator for evaluating the dimensional stability of the anchor holes.*

*MARQUEUR DE L'USURE DU FORET*

*Indicateur pour évaluer la stabilité dimensionnelle des trous.*

*MARCADOR DEL DESGASTE DE LA BROCA*

*Es un indicador para evaluar la estabilidad dimensional de los agujeros.*

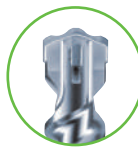

#### PONTA CENTRADORA

Com um ângulo de 130° garante alta precisão da perfuração e furação concêntrica.

*CENTERING POINT*

*With 130° point angle ensures highly accurate, precise drilling and guarantees optimal drill guidance.*

*LA POINTE EN CARBURE MASSIVE AVEC CHANFREIN BREVETÉ*

*Permet le forage précis en béton armé.*

*PUNTA CENTRADORA*

*Con un ángulo de 130° garantiza alta precisión de la perforación y perforado concéntrico.*



#### PONTA DE CARBONETO MACIÇA COM CHANFREADO PATENTEADO

Permite uma furação precisa em betão reforçado

*THE MASSIVE CARBIDE TIP WITH PATENTED REINFORCING CHAMFERING*

*Provides optimal drilling performance into reinforced concrete.*

*LA POINTE EN CARBURE MASSIVE AVEC CHANFREIN BREVETÉ*

*Permet le forage précis en béton armé.*

*LA PUNTA DE CARBURO SUAVE CON BISELADO PATENTADO*

*Permite un perforado preciso en hormigón reforzado.*



#### CORPO CENTRAL DA BROCA REFORÇADO

Atinge o equilíbrio ideal entre o volume e a resistência à ruptura.

As vibrações são amortecidas resultando assim em maior energia de impacto sobre a cabeça da broca.

*THE REINFORCED-CORE FLUTE*

*Achieves the optimum balance between volume and break resistance.*

*Vibrations are dampened and resulting in more impact energy on the carbide tips.*

*CORPS CENTRAL DU FORET RENFORCÉ*

*Atteint l'équilibre idéal entre le volume et la résistance à la rupture.*

*Les vibrations sont amorties, donnant ainsi plus d'énergie d'impact sur la tête du foret.*

*CUERPO CENTRAL DE LA BROCA REFORZADO*

*Alcanza el equilibrio ideal entre el volumen y la resistencia a la ruptura.*

*Las vibraciones son amortiguadas resultando así una mayor energía de impacto sobre la cabeza de la broca.*



#### DE ACORDO COM PGM

Permite efectuar furos concêntricos para um encaixe perfeito da bucha.

*PGM CONFORMITY*

*Stands for precisely fitting anchor holes and precise concentricity.*

*HOMOLOGATION PGM*

*Permet de faire des trous concentriques pour un ajustement parfait du foret.*

*EN CONFORMIDAD CON PGM*

*Permite efectuar agujeros concéntricos para un encaje perfecto del taco.*



Premium / Premium / Premium / Premium

SDS MAX



CÓDIGO CODE / CODE / CÓDIGO	DIMENSÕES SIZE / DIMENSIONS / MEDIDA	COMPRIMENTO TRABALHO WORKING LENGTH / LONGUEUR DE TRAVAIL / LONGITUD DE TRABAJO	EMBALAGEM QUANTITY / EMBALLAGE / EMBALAJE
034621125400	Ø12 x 540	400	1
034621145400	Ø14 x 540	400	1
034621165400	Ø16 x 540	400	1
034621185400	Ø18 x 540	400	1
034621205200	Ø20 x 520	400	1
034621225200	Ø22 x 520	400	1
034621245200	Ø24 x 520	400	1
034621255200	Ø25 x 520	400	1
034621285700	Ø28 x 570	450	1
034621305700	Ø30 x 570	450	1
034621325700	Ø32 x 570	450	1
034621355700	Ø35 x 570	450	1
034621405700	Ø40 x 570	450	1
034621525700	Ø52 x 520	450	1



**Especialmente adequada para furação agressiva devido à inovadora geometria da cabeça e à geometria da espiral**  
Rotary hammer drill bit Premium is a robust, aggressive power pack, combining an innovative head geometry and an established flute geometry  
Permet le perçage agressif dû à une combinaison de la géométrie de la tête innovatrice et la géométrie en spirale  
Permite un perforación agresiva debido a la combinación de la geometría de la cabeza innovadora y la geometría de la espiral



## Broca Craneana SDS Max

Hollow Core Bit - SDS Max Adapter / Trépan Marteau SDS Max / Broca Corona SDS Max

# SDS MAX



CÓDIGO CODE / CODE / CÓDIGO	DIMENSÕES SIZE / DIMENSIONS / MEDIDA	EMBALAGEM QUANTITY / EMBALLAGE / EMBALAJE	CÓDIGO CODE / CODE / CÓDIGO	DIMENSÕES SIZE / DIMENSIONS / MEDIDA	EMBALAGEM QUANTITY / EMBALLAGE / EMBALAJE
034861035000	Ø35 x 100	1	034861080000	Ø80 x 100	1
034861040000	Ø40 x 100	1	034861090000	Ø90 x 100	1
034861050000	Ø50 x 100	1	034861100000	Ø100 x 100	1
034861066000	Ø65 x 100	1	034861125000	Ø125 x 100	1



**Especialmente indicada para trabalhar em betão, alvenaria, pedra natural e pedra calcária, em martelos SDS MAX**  
Ideal for working in concrete, masonry, natural stone and calcareous sandstone. The Hollow Core Bit can be used with SDS Max adapter for rotary hammer drills  
Idéal pour travailler le béton, la maçonnerie, la pierre naturelle et la roche calcaire. Le trépan doit être utilisé en marteaux SDS MAX  
Ideal para trabajar en hormigón, mampostería, piedra natural y piedra calcárea. La broca corona debe ser usada en martillos SDS MAX



## Acessórios / Accessory / Accessoire / Accesorio

### Adaptador SDS Max de formato cónico

/ SDS Max adapter with conical shape / Adaptateur SDS Max en format conique / Adaptador SDS Max de formato cónico



CÓDIGO CODE / CODE / CÓDIGO	DIMENSÕES SIZE / DIMENSIONS / MEDIDA	EMBALAGEM QUANTITY / EMBALLAGE / EMBALAJE
034881025000	180	1
034881045000	450	1



### Broca centradora / Centering Drill Bit / Foret centrage / Broca centradora



CÓDIGO CODE / CODE / CÓDIGO	DIMENSÕES SIZE / DIMENSIONS / MEDIDA	EMBALAGEM QUANTITY / EMBALLAGE / EMBALAJE
034871012000	Ø11 x 120	1

### Ponteiro / Drift key, flat / Aiguille / Cuña



CÓDIGO CODE / CODE / CÓDIGO	DIMENSÕES SIZE / DIMENSIONS / MEDIDA	EMBALAGEM QUANTITY / EMBALLAGE / EMBALAJE
034871012001	140	1

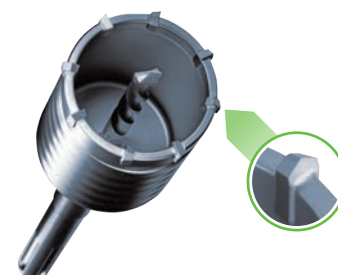



# CORTE

Cut / Coupe / Corte

## SDS MAX Broca Perfuradora SDS Max

SDS Max Breakthrough Core Cutter / Foret Perforateur SDS Max / Broca Perforadora SDS Max



CÓDIGO CODE / CODE / CÓDIGO	DIMENSÕES SIZE / DIMENSIONS / MEDIDA	EMBALAGEM QUANTITY / EMBALLAGE / EMBALAJE
033331445550	Ø45 x 550	1
033331445990	Ø45 x 990	1
033331455550	Ø55 x 550	1
033331455990	Ø55 x 990	1

CÓDIGO CODE / CODE / CÓDIGO	DIMENSÕES SIZE / DIMENSIONS / MEDIDA	EMBALAGEM QUANTITY / EMBALLAGE / EMBALAJE
033331465550	Ø65 x 550	1
033331465990	Ø65 x 990	1
033331480550	Ø80 x 550	1



**Especialmente indicada para furar grandes diâmetros (40-80mm) para passagem de tubos e cabos**

Useful for drilling into large diameters (Ø40 - 80 mm). Special for breakthrough cuts for cables and pipes

Indiqué pour perforer des grands diamètres (Ø40 - 80 mm). Foret idéal pour la réalisation de trous permettant le passage de tuyaux et câbles

Especialmente adecuada para perforar grandes diâmetros (Ø40 - 80 mm). Broca ideal para la realización de agujeros, para el paso de tubos y cables



## SDS MAX Guilhos SDS Max

Chisels SDS Max Shank / Burins SDS Max / Cinceles Max Plus

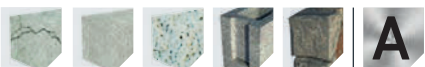

**Ponteiro**  
/ Pointed chisel  
/ Pointe/rolle / Puntero



**Perfuração inicial de lajes de betão e demolição**  
Starts holes in concrete slabs, general chipping and breaking  
Perforage initial de dalles en béton et démolition  
Perforación inicial de losa de hormigón y demolição

2

**Liso**  
/ Flat chisel  
/ Plat / Plano



**Para demolição e cinzelagem geral de tijolo, betão e pedra, para aplicações normais de passagem de cabos**  
For general chiseling and breaking work in brickwork, concrete and loose stone, for example when laying cables  
Pour démolition et cisèlement général de brique, béton et pierre, pour applications normales de passage de câbles  
Para demolición y cinzelado general de ladrillo, hormigón y piedra, para aplicaciones normales de paso de cables

3

**Pá Larga**  
/ Spade chisel  
/ Bêche / Pala ancha



**Para a remoção de grandes quantidades de materiais em grandes extensões**  
For removing large quantities of materials  
Pour le retrait de grandes quantités de matériaux  
Para la eliminación de grandes cantidades de materiales

4

**Goiva**  
/ Hollow chisel  
/ Gouge / Hueco



**Para abertura de canais estreitos em betão**  
For cutting narrow channels into concrete  
Pour ouverture de voies étroites en béton  
Para apertura de canales estrechos en hormigón



	CÓDIGO CODE / CODE / CÓDIGO	COMPRIMENTO LENGTH / LONGUEUR / LONGITUD	LARGURA WIDTH / LARGEUR / LARGO	EMBALAGEM QUANTITY / EMBALLAGE / EMBALAJE
1	034921004000	400	-	1
2	034921254000	400	25	1
3	034921754000	400	50	1
4	034921224000	300	26	1



## Broca Encaixe Cilíndrico Multimateriais Premium

Multi Construction Multi-Purpose Drill Bit Premium / Foret Polyvalent Multi Construction Premium / Broca de Encaixe Cilíndrico Múltiplos Materiales Premium



CÓDIGO CODE / CODE / CÓDIGO	DIMENSÕES SIZE / DIMENSIONS / MEDIDA	COMPRIMENTO TRABALHO WORKING LENGTH / LONGUEUR DE TRAVAIL / LONGITUD DE TRABAJO	EMBALAGEM QUANTITY / EMBALLAGE / EMBALAJE
033926040750	Ø4 x 75	40	1
033926050850	Ø5 x 85	50	1
033926550850	Ø5,5 x 85	50	1
033926061000	Ø6 x 100	60	1
033926061500	Ø6 x 150	90	1
033926651000	Ø6,5 x 100	60	1

CÓDIGO CODE / CODE / CÓDIGO	DIMENSÕES SIZE / DIMENSIONS / MEDIDA	COMPRIMENTO TRABALHO WORKING LENGTH / LONGUEUR DE TRAVAIL / LONGITUD DE TRABAJO	EMBALAGEM QUANTITY / EMBALLAGE / EMBALAJE
033926071000	Ø7 x 100	60	1
033926081200	Ø8 x 120	80	1
033926082500	Ø8 x 250	200	1
033926091200	Ø9 x 120	80	1
033926101200	Ø10 x 120	80	1
033926121500	Ø12 x 150	90	1
033926142500	Ø14 x 250	200	1



**Especialmente adequada em materiais de construção sensíveis em que não é necessário percussão**

Suitable for applications with soft or fragile building materials where is not necessary percussion  
Convient particulièrement aux matériaux de construction sensibles ou il n'est pas nécessaire percussion  
Especialmente adecuada en materiales de construcción sensibles donde no se necesita percusión



**Cerâmica**

Ceramics / Poterie / Cerámica



**Material Multicamada**

Multilayer Material / Matériau Multicouches / Materiales Multicapas



**Tijolo Refratário**

Firebrick / Brique Réfractaire / Ladrillo Refractorio



**Madeira**

Wood / Bois / Madera



## Broca de Encaixe Cilíndrico para Grés e Porcelanato

Rotary Drill Bit for Hard Building Materials / Foret Cylindrique pour Grès et Porcelaine / Broca de Encaixe Cilíndrico para Gres y Porcelanato



CÓDIGO CODE / CODE / CÓDIGO	DIMENSÕES SIZE / DIMENSIONS / MEDIDA	COMPRIMENTO TRABALHO WORKING LENGTH / LONGUEUR DE TRAVAIL / LONGITUD DE TRABAJO	EMBALAGEM QUANTITY / EMBALLAGE / EMBALAJE
033924040850	Ø4 x 85	45	1
033924061000	Ø6 x 100	60	1
033924081250	Ø8 x 125	80	1



**Especialmente indicada para perfuração fácil e segura de todos os tipos de cerâmica, incluindo azulejo, grés e porcelanato**

Easy and safe drilling of all kinds of tile, including ceramic tile, gres and porcelanato tiles  
Perforage facile et sûre de tous types de céramiques, incluant carrelage, grès et porcelaine  
Perforación fácil y segura de todo tipo de cerámica, incluyendo azulejo, gres y porcelanato



**A REFRIGERAÇÃO À ÁGUA MELHORA A VIDA ÚTIL DA BROCA BEM COMO O NÍVEL DE DESEMPENHO DA MESMA**

Water cooling improves life of bit / La réfrigération à l'eau améliore la vie utile du foret ainsi que son niveau de performance  
/ La refrigeración a agua mejora la vida útil de la broca así como el nivel de rendimiento de la misma





# DIN 338

## Brocas HSS DIN 338

Twist Drills HSS DIN 338 / Forets HSS DIN 338 / Brocas HSS DIN 338

HSS



118°



HSS Rebaixada

/ Reduced shank / Queue réduite / Rebajada

HSS 5% Co



135°



HSS 8% Co



135°



HSS	HSS 5% Co	HSS 8% Co	HSS Reb	DIMENSÕES SIZE / DIMENSIONS / MEDIDA	COMPRIMENTO TRABALHO WORKING LENGTH / LONGUEUR DE TRAVAIL / LONGITUD DE TRABAJO	EMBALAGEM QUANTITY / EMBALLAGE / EMBALAJE
033821010000	—	—	—	Ø1 x 34	12	10
033821015000	—	—	—	Ø1,5 x 43	20	10
033821020000	036121020000	036221020000	—	Ø2 x 49	24	10
033821025000	036121025000	036221025000	—	Ø2,5 x 57	30	10
033821027500	036121027500	036221027500	—	Ø2,75 x 61	33	10
033821030000	036121030000	036221030000	—	Ø3 x 61	33	10
033821032500	036121032500	036221032500	—	Ø3,25 x 65	36	10
033821035000	036121035000	036221035000	—	Ø3,5 x 70	39	10
033821037500	036121037500	036221037500	—	Ø3,75 x 70	39	10
033821040000	036121040000	036221040000	—	Ø4 x 75	43	10
033821042500	036121042500	036221042500	—	Ø4,25 x 75	43	10
033821045000	036121045000	036221045000	—	Ø4,5 x 80	47	10
033821047500	—	036221047500	—	Ø4,75 x 80	47	10
033821050000	036121050000	036221050000	—	Ø5 x 86	52	10
033821052500	036121052500	036221052500	—	Ø5,25 x 86	52	10
033821055000	036121055000	036221055000	—	Ø5,5 x 93	57	10
033821057500	—	036221057500	—	Ø5,75 x 99	57	10
033821060000	036121060000	036221060000	—	Ø6 x 93	57	10
033821062500	—	—	—	Ø6,25 x 101	63	10
033821065000	036121065000	036221065000	—	Ø6,5 x 101	63	10
033821067500	—	—	—	Ø6,75 x 101	63	10
033821070000	036121070000	036221070000	—	Ø7 x 109	69	10
033821072500	—	—	—	Ø7,25 x 109	69	10
033821075000	036121075000	036221075000	—	Ø7,5 x 109	69	10
033821077500	—	—	—	Ø7,75 x 117	75	10
033821080000	036121080000	036221080000	—	Ø8 x 117	75	10
033821082500	—	—	—	Ø8,25 x 117	75	5
033821085000	036121085000	036221085000	—	Ø8,5 x 117	75	5
033821087500	—	—	—	Ø8,75 x 125	81	5
033821090000	036121090000	036221090000	—	Ø9 x 125	81	5
033821092500	—	—	—	Ø9,25 x 125	81	5
033821095000	036121095000	036221095000	—	Ø9,5 x 125	81	5
033821097500	—	—	—	Ø9,75 x 133	87	5
033821100000	036121100000	036221100000	—	Ø10 x 133	87	5
033821102500	036121102500	036221102500	—	Ø10,25 x 133	87	5
033821105000	036121105000	036221105000	—	Ø10,5 x 133	87	5
033821107500	—	—	—	Ø10,75 x 142	94	5
033821110000	036121110000	036221110000	—	Ø11 x 142	94	5
033821112500	—	—	—	Ø11,25 x 142	94	5
033821115000	036121115000	036221115000	—	Ø11,5 x 142	94	5
033821120000	036121120000	036221120000	—	Ø12 x 151	101	5
033821125000	036121125000	—	—	Ø12,5 x 151	101	5
033821130000	036121130000	—	—	Ø13 x 151	101	5
033821135000	—	—	—	Ø13,5 x 160	108	1
033821140000	—	—	033821140001	Ø14 x 160	108	1
033821150000	—	—	033821150001	Ø15 x 169	114	1
033821155000	—	—	033821155001	Ø15,5 x 178	120	1
033821160000	—	—	033821160001	Ø16 x 178	120	1
033821165000	—	—	033821165001	Ø16,5 x 184	125	1
033821170000	—	—	033821170001	Ø17 x 184	125	1
033821175000	—	—	033821175001	Ø17,5 x 191	130	1
033821180000	—	—	033821180001	Ø18 x 191	130	1
033821185000	—	—	033821185001	Ø18,5 x 198	135	1
033821190000	—	—	033821190001	Ø19 x 198	135	1
033821195000	—	—	033821195001	Ø19,5 x 205	140	1
033821200000	—	—	033821200001	Ø20 x 205	140	1
033821205000	—	—	—	Ø20,5 x 210	145	1
033821210000	—	—	033821210001	Ø21 x 210	145	1
—	—	—	033821215001	Ø21,5 x 210	150	1
033821220000	—	—	033821220001	Ø22 x 210	150	1



Aços macio, ligas de alumínio, zinco, cobre fino, zamak, plásticos e madeira

Long chips soft steels, like (long chips) aluminium alloys, zinc, fine copper, zamak, plastics and wood

Acier doux, aluminium, zinc, cuivre fin, zamak, plastique et bois

Aceros blandos y de virutas largas como aleaciones de aluminio (de virutas largas), zinc, cobre fino, zamak, plasticos y madera





## Conjuntos Brocas HSS DIN 338

SDS Plus Assortments / Jeu de Forets SDS Plus / Conjunto de Brocas SDS Plus

# DIN 338

### Conjunto 19 Brocas HSS - M2

/ Set of 19 HSS - M2 Drills / Jeu de 19 Forets HSS - M2 / Conjunto de 19 Brocas HSS - M2



118°



### Conjunto 19 Brocas HSS - M2

/ Set of 19 HSS - M2 Drills / Jeu de 19 Forets HSS - M2 / Conjunto de 19 Brocas HSS - M2

GRIP BOX



118°



**DIMENSÕES**  
SIZE / DIMENSIONS / MEDIDA

1.0 | 1.5 | 2.0 | 2.5 | 3.0  
| 3.5 | 4.0 | 4.5 | 5.0 | 5.5 | 6.0  
| 6.5 | 7.0 | 7.5 | 8.0 | 8.5 | 9.0 | 9.5 | 10.0

**CÓDIGO**  
CODE / CODE / CÓDIGO

**EMBALAGEM**  
QUANTITY / EMBALLAGE  
/ EMBALAJE

036021030000

1



**DIMENSÕES**  
SIZE / DIMENSIONS / MEDIDA

1.0 | 1.5 | 2.0 | 2.5 | 3.0  
| 3.5 | 4.0 | 4.5 | 5.0 | 5.5 | 6.0  
| 6.5 | 7.0 | 7.5 | 8.0 | 8.5 | 9.0 | 9.5 | 10.0

**CÓDIGO**  
CODE / CODE / CÓDIGO

**EMBALAGEM**  
QUANTITY / EMBALLAGE  
/ EMBALAJE

036021020000

1

### Conjunto 170 Brocas HSS - M2

/ Set of 170 HSS - M2 Drills / Jeu de 170 Forets HSS - M2 / Conjunto de 170 Brocas HSS - M2



118°



x10

**DIMENSÕES**  
SIZE / DIMENSIONS / MEDIDA

1.0 | 1.5 | 2.0 | 2.5 | 3.0  
| 3.5 | 4.0 | 4.5 | 5.0 | 5.5  
| 6.0 | 6.5 | 7.0 | 7.5 | 8.0

x5



**CÓDIGO**  
CODE / CODE / CÓDIGO

**EMBALAGEM**  
QUANTITY / EMBALLAGE / EMBALAJE

036021010000

1

## 5% Co | HSS - M35

### Conjunto 19 Brocas HSS - M35

/ Set of 19 HSS - M35 Drills / Jeu de 19 Forets HSS - M35 / Conjunto de 19 Brocas HSS - M35



135°



GRIP BOX



135°



**DIMENSÕES**  
SIZE / DIMENSIONS / MEDIDA

1.0 | 1.5 | 2.0 | 2.5 | 3.0 | 3.5 | 4.0 | 4.5 | 5.0 | 5.5  
| 6.0 | 6.5 | 7.0 | 7.5 | 8.0 | 8.5 | 9.0 | 9.5 | 10.0

**CÓDIGO**  
CODE / CODE / CÓDIGO

**EMBALAGEM**  
QUANTITY / EMBALLAGE / EMBALAJE

036021100000

1



x10

**DIMENSÕES**  
SIZE / DIMENSIONS / MEDIDA

1.0 | 1.5 | 2.0 | 2.5 | 3.0 | 3.5 | 4.0 | 4.5  
| 5.0 | 5.5 | 6.0 | 6.5 | 7.0 | 7.5 | 8.0

x5



**CÓDIGO**  
CODE / CODE / CÓDIGO

**EMBALAGEM**  
QUANTITY / EMBALLAGE / EMBALAJE

036021090000

1



## CORTE

Cut / Coupe / Corte

# DIN 333A

## Brocas de Centrar HSS - DIN 333A

HSS Center Drill Bits - DIN 333A / Forets de centrage HSS - DIN 333A / Brocas de centrar HSS - DIN 333A



A

CÓDIGO CODE / CODE / CÓDIGO	DIMENSÕES SIZE / DIMENSIONS / MEDIDA	EMBALAGEM QUANTITY / EMBALLAGE / EMBALAJE
036421020000	Ø2 x 40	1
036421031500	Ø3.15 x 50	1
036421040000	Ø4 x 56	1
036421050000	Ø5 x 63	1
036421063000	Ø6.3 x 71	1



**Possibilidade de fazer furos concêntricos numa única operação | Pode ser usado em ambos os lados**

Makes center holes in a single operation | Can be used on both sides

Possibilité de faire des trous concéntriques en une opération | Peut être utiliser des deux côtés

Possibilidad de hacer agujeros concéntricos en una única operación | Puede ser usado por ambos lados

# DIN 1897

## Broca Dupla HSS-G - DIN 1897

HSS Double End Drill Bits - DIN 1897 / Foret Double HSS-G - DIN 1897 / Broca Doble HSS-G - DIN 1897



A

CÓDIGO CODE / CODE / CÓDIGO	DIMENSÕES SIZE / DIMENSIONS / MEDIDA	COMPRIMENTO TRABALHO WORKING LENGTH / LONGUEUR DE TRAVAIL / LONGITUD DE TRABAJO	EMBALAGEM QUANTITY / EMBALLAGE / EMBALAJE
036321040000	Ø4 x 470	55	1
036321045000	Ø4.5 x 470	58	1
036321050000	Ø5 x 470	62	1
036321055000	Ø5.5 x 470	66	1
036321060000	Ø6 x 470	66	1



**Ideal para ser usado em chapas de aço | Pode ser usado em ambos os lados**

Specially to be used on sheet metal | Can be used on both sides

Idéale pour être utilisé sur feuilles en acier | Peut être utiliser des deux côtés

Ideal para ser usado en chapas de acero | Puede ser usado por ambos lados

# DIN 335C

## Escareador de 90° - DIN 335 Tipo C

Countersink Bit 90° - DIN 335 Type C / Fraise à 3 dents de 90° DIN 335 Type C / Avellanador de 90° - DIN 335 Tipo C



A

CÓDIGO CODE / CODE / CÓDIGO	DIMENSÕES SIZE / DIMENSIONS / MEDIDA	ENCAIXE Ø SHANK / QUEUE / ENCAJE	PARAFUSO SCREW / VIS / TORNILLO	EMBALAGEM QUANTITY / EMBALLAGE / EMBALAJE
035021063000	Ø6.3 x 45	5	M3	1
035021083000	Ø8.3 x 50	6	M4	1
035021104000	Ø10.4 x 50	6	M5	1
035021124000	Ø12.4 x 56	8	M6	1



**Escareador | Limpa arestas de possíveis rebarbas | Chanfreado**

Countersinking | Deburring | Chamfering

Fraise | Nettoie les arêtes de possibles bavures | Chanfreiné

Avellanador | Limpia aristas de posibles rebabas | Biselado



## Brocas Escalonadas

Step Drill Bits / Fraises Étagées / Brocas Escalonadas

M2



A



Para uso em aço (0,1 a 4 mm de espessura), metais não ferrosos (0,1 a 5 mm) e em plástico (até 10 mm)

For use on steel (0,1 to 4 mm thick) non ferrous metals (0,1 to 5 mm) and plastic (up to 10 mm)  
Pour utiliser sur acier (0,1 à 4 mm d'épaisseur), métaux non ferreux (0,1 à 5 mm) et plastique (jusqu'à 10 mm)  
Para uso en acero (0,1 a 4 mm de espesor), metales no ferrosos (0,1 a 5 mm) y en plástico (hasta 10 mm)

M35



A



Para uso em aço e aço inoxidável  
For use on steel and stainless steel  
Pour utiliser sur acier et acier inoxydable  
Para uso en acero y acero inoxidable

Co + Ti



Co  
Ti



Ideal para uso intensivo  
For use on repetitive drilling  
Idéale pour une utilisation intensive  
Ideal para uso intensivo



	CÓDIGO CODE / CODE / CÓDIGO	FUROS HOLES / TROUS / AGUJEROS	Ø	PASSO DO Ø STEP GRADIENT / PAS DU DIAMÈTRE / PASO DEL DIÁMETRO	ENCAIXE SHANK / QUEUE / ENCAJE		COMPRIMENTO TOTAL TOTAL LENGTH / LONGUEUR TOTAL / LARGO TOTAL	EMBALAGEM QUANTITY / EMBALLAGE / EMBALAJE
					Ø	COMPRIMENTO LENGTH / LONGUEUR / LARGO		
M2	035121043000	14	4 - 30	2	10	24	100	1
	035121060000	12	6 - 30	2	10	24	98	1
	035121043001	14	4 - 30	2	10	24	100	1
M35	035121043900	12	6 - 39	3	10	24	99	1
	035121060001	12	6 - 30	2	10	24	98	1
	035121141000	9	4 - 12	1	5,6	19	79	1
Co + Ti	035121142000	9	4 - 20	2	10	23	100	1
	035121140000	14	4 - 30	2	10	23	100	1
	035121164000	14	6 - 37	3/2	10	23	98	1

### Conjunto 3 Brocas Escalonadas

Set of 3 Step Drill Bits / Jeu de 3 Fraises Étagées /  
Conjunto de 3 Brocas Escalonadas

4-12 | 4-20 | 4-30

A

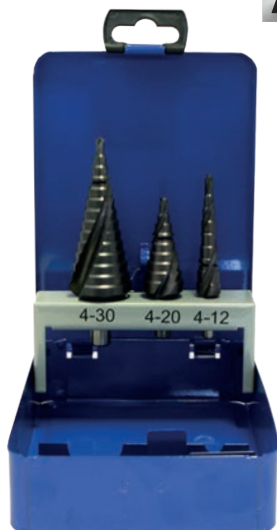

A



Ideal para trabalhos em chapa metálica | Utilizada por canalizadores, eletricitistas e mecânicos de automóveis  
Ideal tool for sheet metal workers, plumbers, electric contractors and auto mechanics  
Idéal pour des travaux sur feuilles métalliques, plombiers, électriciens et mécaniciens automobiles  
Ideal para trabajos en chapa metálica, canalizadores, electricistas y mecánicos de automóviles

CÓDIGO CODE / CODE / CÓDIGO	EMBALAGEM QUANTITY / EMBALLAGE / EMBALAJE
035121200000	1

CÓDIGO CODE / CODE / CÓDIGO	FUROS HOLES / TROUS / AGUJEROS	Ø	PASSO DO Ø STEP GRADIENT / PAS DU DIAMÈTRE / PASO DEL DIÁMETRO	ENCAIXE SHANK / QUEUE / ENCAJE		COMPRIMENTO TOTAL TOTAL LENGTH / LONGUEUR TOTAL / LARGO TOTAL	EMBALAGEM QUANTITY / EMBALLAGE / EMBALAJE
				Ø	COMPRIMENTO LENGTH / LONGUEUR / LARGO		
001190899335	15	6 - 35	2 / 3	-	-	90	1
001190899302	5	4 - 12	2	-	-	65	1



# CORTE

Cut / Coupe / Corte

## Broca Craneana HSS M2 metal

HSS Hole Saws / Trépan HSS M2 / Broca Corona HSS M2 metal



CÓDIGO CODE / CODE / CÓDIGO	DIMENSÕES SIZE / DIMENSIONS / MEDIDA	EMBALAGEM QUANTITY / EMBALLAGE / EMBALAJE
033421010000	10	1
033421011000	11	1
033421012000	12	1
033421013000	13	1
033421014000	14	1
033421015000	15	1
033421016000	16	1
033421017000	17	1
033421018000	18	1
033421019000	19	1
033421020000	20	1
033421021000	21	1
033421022000	22	1
033421023000	23	1
033421024000	24	1
033421025000	25	1
033421026000	26	1
033421027000	27	1
033421028000	28	1
033421029000	29	1
033421030000	30	1
033421031000	31	1
033421032000	32	1
033421033000	33	1
033421034000	34	1
033421035000	35	1
033421036000	36	1
033421037000	37	1
033421038000	38	1
033421039000	39	1
033421040000	40	1
033421052000	52	1
033421065000	65	1



As brocas são apropriadas para a perfuração de aço, ferro, alumínio, ligas metálicas leves, ferro fundido ou plástico com espessuras de 7-8 mm e pode ser também utilizado em superfícies curvas

They are suitable for drilling steel, iron, aluminium, light alloys, cast iron and plastics with thickness of 7-8 mm and can be also used on curved surface

Les trépan sont appropriés pour le perçage de l'acier, aluminium, alliages métalliques légers, fonte ou plastique avec une épaisseur de 7-8 mm et peut être utilisé en surfaces courbes

Las brocas son apropiadas para la perforación de acero, hierro, aluminio, aleaciones metálicas leves, hierro fundido o plástico con espesores de 7-8 mm y puede ser también utilizado en superficies curvas

## Broca Craneana TCT Aço inox

TCT Hole Saws / Trépan TCT acier inox / Broca Corona TCT acero inox



CÓDIGO CODE / CODE / CÓDIGO	DIMENSÕES SIZE / DIMENSIONS / MEDIDA	EMBALAGEM QUANTITY / EMBALLAGE / EMBALAJE
033121014000	14	1
033121015000	15	1
033121016000	16	1
033121017000	17	1
033121018000	18	1
033121019000	19	1
033121020000	20	1
033121021000	21	1
033121022000	22	1
033121023000	23	1
033121024000	24	1
033121025000	25	1
033121026000	26	1
033121027000	27	1
033121028000	28	1
033121029000	29	1
033121030000	30	1
033121031000	31	1
033121032000	32	1
033121033000	33	1
033121034000	34	1
033121035000	35	1
033121036000	36	1
033121037000	37	1
033121038000	38	1
033121039000	39	1
033121040000	40	1



Cabeça em carboneto de tungstênio. Apropriada para a perfuração em inox, ferro fundido rígido, aço, ligas de aço, alumínio e cobre

Tungsten carbide Head. Suitable for drilling in stainless steel, hard cast iron, steel, alloy steels, aluminium and copper

Tête en carbure de tungstène. Approprié pour le perçage sur inox, fonte dure, acier, alliages d'acier, aluminium et cuivre

Cabeza de carburo de tungsteno. Apropriada para la perforación en inox, hierro fundido rígido, acero, aleaciones de acero, aluminio y cobre

## Serra Craneana Bimetálica AISI M42 (HSS - Co 8%)

Bi-Metal Variable Pitch Hole Saw AISI M42 (HSS - Co 8%) / Scie Trépan Bimétallique AISI M42 (HSS - Co 8%) / Sierra Corona Bimetálica AISI M42 (HSS - Co 8%)



CÓDIGO CODE / CODE / CÓDIGO	DIMENSÕES SIZE / DIMENSIONS / MEDIDA	EMBALAGEM QUANTITY / EMBALLAGE / EMBALAJE
033739016000	Ø16 x 38	1
033739019000	Ø19 x 38	1
033739020000	Ø20 x 38	1
033739022000	Ø22 x 38	1
033739025000	Ø25 x 38	1
033739029000	Ø29 x 38	1
033739030000	Ø30 x 38	1
033739032000	Ø32 x 38	1
033739035000	Ø35 x 38	1
033739038000	Ø38 x 38	1
033739041000	Ø41 x 38	1
033739044000	Ø44 x 38	1

CÓDIGO CODE / CODE / CÓDIGO	DIMENSÕES SIZE / DIMENSIONS / MEDIDA	EMBALAGEM QUANTITY / EMBALLAGE / EMBALAJE
033739046000	Ø46 x 38	1
033739051000	Ø51 x 38	1
033739054000	Ø54 x 38	1
033739057000	Ø57 x 38	1
033739064000	Ø64 x 38	1
033739070000	Ø70 x 38	1
033739076000	Ø76 x 38	1
033739090000	Ø90 x 38	1
033739100000	Ø100 x 38	1
033739102000	Ø102 x 38	1
033739111000	Ø111 x 38	1



ADAPTADOR 7/16  
THREADED ADAPTER 7/16 / ADAPTATEUR 7/16 / ADAPTADOR 7/16

033722314030	14 - 30	1
033722332203	32 - 203	1



BROCA CENTRADORA HSS  
CENTRING DRILL HSS / FORET DE CENTRAGE HSS / BROCA CENTRADORA HSS

033723063574	6.35 x 74	1
--------------	-----------	---



Corte fácil, rápido e sem rebarba | Elevado tempo de vida útil | Profundidade de corte até 38 mm

Countersinking | Deburring | Chamfering

Coupe facile, rapide et sans bavure | Temps de vie utile élevée | Profondeur de coupe jusqu'à 38 mm

Corte fácil, rápido y sin rebaba | Elevado tiempo de vida útil | Profundidad de corte hasta 38 mm



## Broca Craneana HSS para Coluna Magnética

HSS Core Drills for Magnetic Drilling Machines / Trépan Marteau HSS pour Colonne Magnétique / Broca Corona HSS para Columna Magnética

**A**

30 mm					
CÓDIGO CODE / CODE / CÓDIGO	Ø	A	B	C	EMBALAGEM QUANTITY / EMBALLAGE / EMBALAJE
030321012000	12	40	63	23	1
030321014000	14				1
030321016000	16				1
030321018000	18				1
030321020000	20				1
030321022000	22				1
030321024000	24				1
030321025000	25				1
030321026000	26				1
030321027000	27				1
030321030000	30				1



50 mm					
CÓDIGO CODE / CODE / CÓDIGO	Ø	A	B	C	EMBALAGEM QUANTITY / EMBALLAGE / EMBALAJE
050321012000	12	60	83	23	1
050321014000	14				1
050321018000	18				1
050321020000	20				1
050321022000	22				1
050321024000	24				1
050321025000	25				1
050321026000	26				1

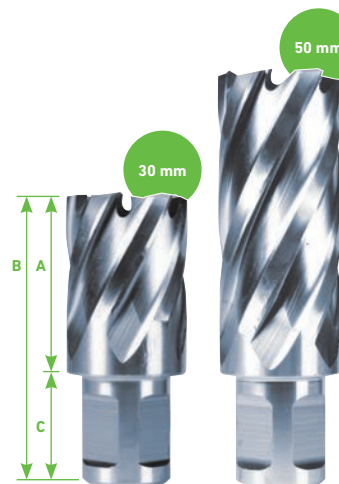

BROCA CENTRADORA HSS COLUNA MAGNÉTICA CENTRING DRILL BIT / FORET DE CENTRAGE HSS COLONNE MAGNÉTIQUE / BROCA CENTRADORA HSS COLUMNA MAGNÉTICA	
030321000000	1

BROCA CENTRADORA HSS COLUNA MAGNÉTICA CENTRING DRILL BIT / FORET DE CENTRAGE HSS COLONNE MAGNÉTIQUE / BROCA CENTRADORA HSS COLUMNA MAGNÉTICA	
050321000000	1



**Todos os trabalhos em metal | Construção de aço estrutural**  
All kind of metal works activities | Steel structural construction  
Tous les travaux en métal | Construction en acier structurel  
Todos los trabajos en metal | Construcción de acero estructural





# CORTE

Cut / Coupe / Corte

## DIN 352

### Jogo 3 Machos Métricos HSS - DIN 352

Standard 3 Pcs Hand TAPS - DIN 352 / Jeu 3 Tarauds Métriques HSS - DIN 352 / Juego 3 Machos Métricos HSS - DIN 352

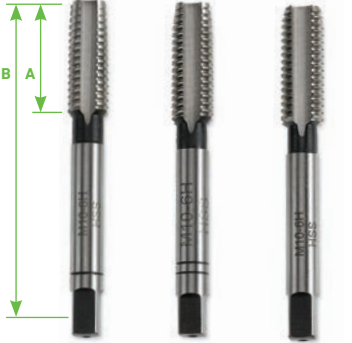

CÓDIGO CODE / CODE / CÓDIGO	ROSCA THREAD / FILETAGE / ROSCA	PASSO DE ROSCA PITCH / PAS DE FILETAGE / PASO DE ROSCA	A	B	EMBALAGEM QUANTITY / EMBALLAGE / EMBALAJE
*	M3	0,5	11	40	1
035321040000	M4	0,7	13	45	1
035321050000	M5	0,8	16	50	1
035321060000	M6	1	19	50	1
035321080000	M8	1,25	22	56	1
035321100000	M10	1,5	24	70	1
*	M12	1,75	29	75	1
*	M14	2	30	80	1
*	M16	2	32	80	1
*	M18	2,5	40	95	1
*	M20	2,5	40	95	1



\* Disponível sob pedido / Available only on request / Disponible sur demande / Disponible bajo pedido



#### Criação de roscas em ferro e aço | Alta precisão de fabrico

Making threads in iron and steel | High precision manufacture

Création de filetages sur fer et acier | Haute précision de fabrication

Creación de roscas en hierro y acero | Alta precisión de fabricación

### Gira Machos Adaptável – Zinco fundido

Adjustable TAP Wrenches - Zinc Die Cast / Tourne-à-gauche - Zinc fondu / Giramachos Adaptable - Zinc fundido



CÓDIGO CODE / CODE / CÓDIGO	Ø	EMBALAGEM QUANTITY / EMBALLAGE / EMBALAJE
035621010100	1 - 10	1
035621040120	4 - 12	1
035621050200	5 - 20	1

### Gira Machos em "T"

TAP Holder with Ratchet - for Taps / Porte-Taraud à Cliquet en "T" / Giramachos em "T"



CÓDIGO CODE / CODE / CÓDIGO	Ø	EMBALAGEM QUANTITY / EMBALLAGE / EMBALAJE
035521030100	3 - 10	1
035521050120	5 - 12	1

### Porta Caçonetes – Zinco fundido

Round Die Stock - Zinc Die Cast / Porte-Filière - Zinc fondu / Portaterrajás - Zinc fundido



CÓDIGO CODE / CODE / CÓDIGO	Ø	EMBALAGEM QUANTITY / EMBALLAGE / EMBALAJE
035421045060	4,5 - 6	1
035421070090	7 - 9	1
035421100110	10 - 11	1
035421120140	12 - 14	1
035421160200	16 - 20	1

### Caçonetes Métricos HSS – DIN 223

Round Dies Metric Thread - DIN223 / Filières Métriques HSS - DIN 223 / Terrajas Métricas HSS - DIN 223



CÓDIGO CODE / CODE / CÓDIGO	ROSCA THREAD / FILETAGE / ROSCA	PASSO DE ROSCA PITCH / PAS DE FILETAGE / PASO DE ROSCA	EMBALAGEM QUANTITY / EMBALLAGE / EMBALAJE
035221040000	4	0,70	1
035221060000	6	1,00	1
035221080000	8	1,25	1
035221100000	10	1,50	1

### Caixa Met. 32 Machos e Caçonetes métricos

Met. Box 32 Males and metric Dies / Boîte Métallique 32 Mâles et Filières Métriques / Caja Met. 32 Machos y Terrajas métricas

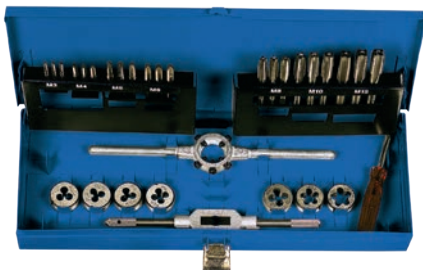

O CONJUNTO INCLUI: / THE SET INCLUDES: / L'ENSEMBLE COMPREND: / EL CONJUNTO INCLUYE:

21 MACHOS: M3, M4, M5, M6, M8, M10, M12 X 3 PÇS  
/ 21 Hand TAPS: M3, M4, M5, M6, M8, M10, M12 x 3 pcs  
/ 21 Tarauds Métriques: M3, M4, M5, M6, M8, M10, M12 x 3 pcs  
/ 21 Machos: M3, M4, M5, M6, M8, M10, M12 x 3 pzs

7 CAÇONETES: M3, M4, M5, M6, M8, M10, M12  
/ 7 Round Dies Metric: M3, M4, M5, M6, M8, M10, M12  
/ 7 Filières Métriques: M3, M4, M5, M6, M8, M10, M12  
/ 7 Terrajas Métricas: M3, M4, M5, M6, M8, M10, M12

1 GIRA MACHOS NR.1.1/2  
/ 1 TAP Wrenches Nr.1.1/2  
/ 1 Tourne-à-gauche Nr.1.1/2  
/ 1 Giramachos Nr.1.1/2

1 PORTA CAÇONETES 25 X 9 MM  
/ 1 Round Die Stock 25x9mm  
/ 1 Porte-Filière 25x9mm  
/ 1 Puerta Terrajas 25x9mm

1 CONTA-FIOS  
/ 1 Thread counter  
/ 1 Porte-Filière  
/ 1 Cuentahilos

1 CHAVE DE FENDA  
/ Screwdriver  
/ 1 Tournevis  
/ 1 Destornillador

CÓDIGO CODE / CODE / CÓDIGO	EMBALAGEM QUANTITY / EMBALLAGE / EMBALAJE
035721320000	1



## Fresas em HSS para Alumínio

HSS Hole Saws / Trépan HSS M2 / Fresa HSS para Alumínio

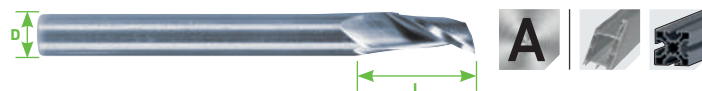

CÓDIGO CODE / CODE / CÓDIGO	DIMENSÕES SIZE / DIMENSIONS / MEDIDA	L	D	EMBALAGEM QUANTITY / EMBALLAGE / EMBALAJE
033522040000	4 x 60	12	8	1
033522050000	5 x 60	12		1
033522060000	6 x 60	14		1
033522080000	8 x 80	15		1

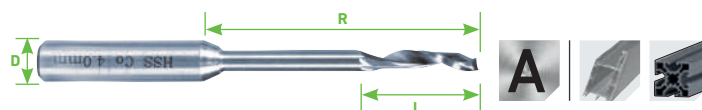

CÓDIGO CODE / CODE / CÓDIGO	DIMENSÕES SIZE / DIMENSIONS / MEDIDA	L/R	D	EMBALAGEM QUANTITY / EMBALLAGE / EMBALAJE
033523040000	4 x 80	16/45	8	1
033523050000	5 x 80	16/45		1
033523060000	6 x 90	16/45		1
033523080000	8 x 100	28/68		1



**Especialmente indicadas para alumínio e PVC**

Mainly aluminium and PVC

Spécialement indiquées pour aluminium et PVC

Especialmente indicadas para aluminio y PVC

## Corta Círculos Ajustável p/ Gesso

Adjustable Hole Cutter / Scie cloche ajustable / Cortacírculos ajustable con recogepolvos



CÓDIGO CODE / CODE / CÓDIGO	Ø	PASSO DO Ø STEP GRADIENT / PAS DU DIAMÈTRE / PASO DEL DIÁMETRO	EMBALAGEM QUANTITY / EMBALLAGE / EMBALAJE
001190560260	51 - 178	6,4	1



## Folha de Serra Bimetálica

Bi-Metal Hacksaw Blades / Lame de Scie Bimétallique / Hoja de Sierra Bimetálica

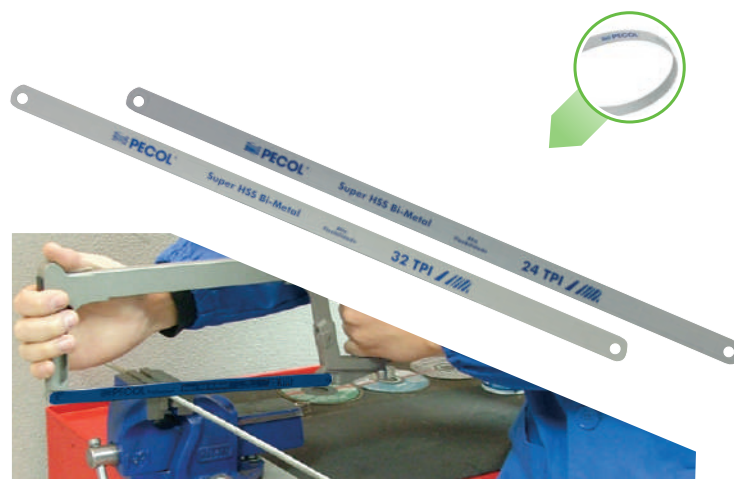

CÓDIGO CODE / CODE / CÓDIGO	TPI	DIMENSÕES SIZE / DIMENSIONS / MEDIDA	EMBALAGEM QUANTITY / EMBALLAGE / EMBALAJE
001521024000	24	300 x 16 x 0.65	100
001521032000	32	300 x 16 x 0.65	100



**Corte de tubos e perfis de aço, aço inox, cobre, alumínio, plástico e metais não ferrosos | Aço estrutural (alta e baixa liga) | Aço (alta e baixa liga) | Aço rápido**

Cutting pipes and profiles in stainless steel, steel, copper, aluminium, plastic and non-ferrous materials | Structural steel (high and low alloy) | Tool steel (high and low alloy) | High speed steel

Coupe de tuyaux et profils en acier, inox, cuivre, aluminium, plastique et métaux non ferreux | Acier structurel (haut et bas alliage) | Acier (haut et bas alliage) | Acier rapide

Corte de tubos y perfiles de acero, acero inox, cobre, aluminio, plástico y metales no ferrosos | Acero estructural (alta y baja aleación) | Acero (alta y baja aleación) | Acero rápido



# CORTE

Cut / Coupe / Corte

## Fita de Serra Bimetálica M42 (68-69 HRC)

Multi-purpose Band Saw Blade M42 (68-69 HRC) / Lame de Scie à Ruban Bimétallique M42 (68-69 HRC) / Hoja de Sierra Bimetálica M42 (68-69 HRC)

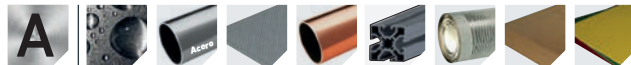

CÓDIGO CODE / CODE / CÓDIGO	DIMENSÕES SIZE / DIMENSIONS / MEDIDA	TPI	TIPO DE DENTE TEETH TYPE / TYPE DE DENT / TIPO DIENTE	EMBALAGEM QUANTITY / EMBALLAGE / EMBALAJE
002602450046	2450 x 27 x 0,90	4/6	P - N	2
002602450508	2450 x 27 x 0,90	5/8	N	2
002602450610	2450 x 27 x 0,90	6/10	N	2
002602450812	2450 x 27 x 0,90	8/12	N	2
002602480610	2480 x 27 x 0,90	6/10	N	2
002602480812	2480 x 27 x 0,90	8/12	N	2
002602500610	2500 x 27 x 0,90	6/10	N	2
002602500812	2500 x 27 x 0,90	8/12	N	2
002602570812	2570 x 27 x 0,90	8/12	N	2
002602710610	2710 x 27 x 0,90	6/10	N	2
002602750046	2750 x 27 x 0,90	4/6	P - N	2
002602750508	2750 x 27 x 0,90	5/8	N	2
002602750610	2750 x 27 x 0,90	6/10	N	2
002602750812	2750 x 27 x 0,90	8/12	N	2
002602751014	2750 x 27 x 0,90	10/14	N	2
002602825610	2825 x 27 x 0,90	6/10	N	2
002602835610	2835 x 27 x 0,90	4/6	P - N	2
002602950610	2950 x 27 x 0,90	6/10	N	2
002602950812	2950 x 27 x 0,90	8/12	N	2
002603010610	3010 x 27 x 0,90	6/10	N	2
002603010812	3010 x 27 x 0,90	8/12	N	2
002603100046	3100 x 27 x 0,90	4/6	P - N	2
002603100812	3100 x 27 x 0,90	8/12	N	2
002603150508	3150 x 27 x 0,90	5/8	N	2
002603160058	3160 x 27 x 0,90	5/8	N	2
002603160812	3160 x 27 x 0,90	8/12	N	2
002603190508	3190 x 27 x 0,90	5/8	N	2
002603660610	3660 x 27 x 0,90	6/10	N	2

**P - Dente P (positivo) – Inclinação 10°, aplicável em barras sólidas, perfis e tubos de espessura mínima 8-10 mm**

Teeth P (positive) – 10° for solid bars, profiles and pipes over 8-10 mm thickness / Dent P (positif) – Inclination 10°, applicable en barres solides, profilés et tubes d'épaisseur minimum de 8-10 mm / Diente P (positivo) – Inclinação 10°, aplicable en barras sólidas, perfiles y tubos con espesor mínimo 8-10 mm

**N - Dente N (neutro) – Inclinação 0°, aplicável em perfis pequenos / médios e tubos de espessura máxima 8-10 mm**

Teeth N (neutral) – 0° for small and medium profiles and tubes up to 8-10 mm / Dent N (neutre) – Inclination 0°, applicables en profilés de petite/moyenne taille et tubes d'épaisseur maximale de 8-10 mm / Diente N (neutro) – Inclinação 0°, aplicable en perfiles pequeños / medios y tubos con espesor máximo 8-10 mm



**Para uso em máquinas de média ou elevada dimensão | Para uso universal e processos de corte de peças em série | Para corte de materiais sólidos e perfis | Distância variável entre dentes | Para aço até 40HRC e metais não ferrosos | Alta resistência ao desgaste e utilização**  
Use on medium to heavy production machines | For universal use and serial cutting | For large profiles and solid materials | Variable pitch teeth | For steels of up to 40 HRC and non-ferrous metals | High wear and heat resistance

Pour usage en machines de moyennes et grandes dimensions | Pour usage universel et processus de coupe de pièces en série | Pour coupe de matériaux solides et profilés | Distance variable entre les dents | Pour acier jusqu'à 40HRC et métaux non ferreux | Haute résistance à l'usure et utilisation

Para uso em máquinas de média o elevada dimensão | Para uso universal y procesos de corte de piezas en serie | Para corte de materiales sólidos y perfiles | Distancia variable entre dientes | Para acero hasta 40HRC y metales no ferrosos | Alta resistencia al desgaste y utilización



**MEDIDAS DISPONÍVEIS SOB CONSULTA**

Measures available on request / Mesures disponibles sur demande / Medidas disponibles bajo consulta



### 0° Dente (Neutro)

/ 0° Rake (Neutral) / 0° Dent (Neutre) / 0° Diente (Neutro)

**Excelente capacidade de arrasto de resíduos**

Excellent chip carrying capacity / Excellente capacité de trainage de résidus / Excelente capacidad de arrastre de residuos

**Redução de vibração harmónica**

Reduces harmonic vibration / Réduction de vibration harmonique / Reducción de vibración armónica



### Gancho (Dente positivo)

/ Hook (Positive Rake) / Crochet (Dent positif) / Gancho (Diente positivo)

**Maior poder de remoção de material**

Better chip formation / Plus grande pouvoir de retrait de matériau / Mayor poder de eliminación de material

**Excelente capacidade de arrasto de resíduos**

Excellent chip carrying capacity / Excellente capacité de trainage des résidus / Excelente capacidad de arrastre de residuos

**Redução de vibração harmónica**

Reduces harmonic vibration / Réduction de vibration harmonique / Reducción de vibración armónica

**Corte mais agressivo**

More aggressive cutting / Coupe plus agressive / Corte más agresivo

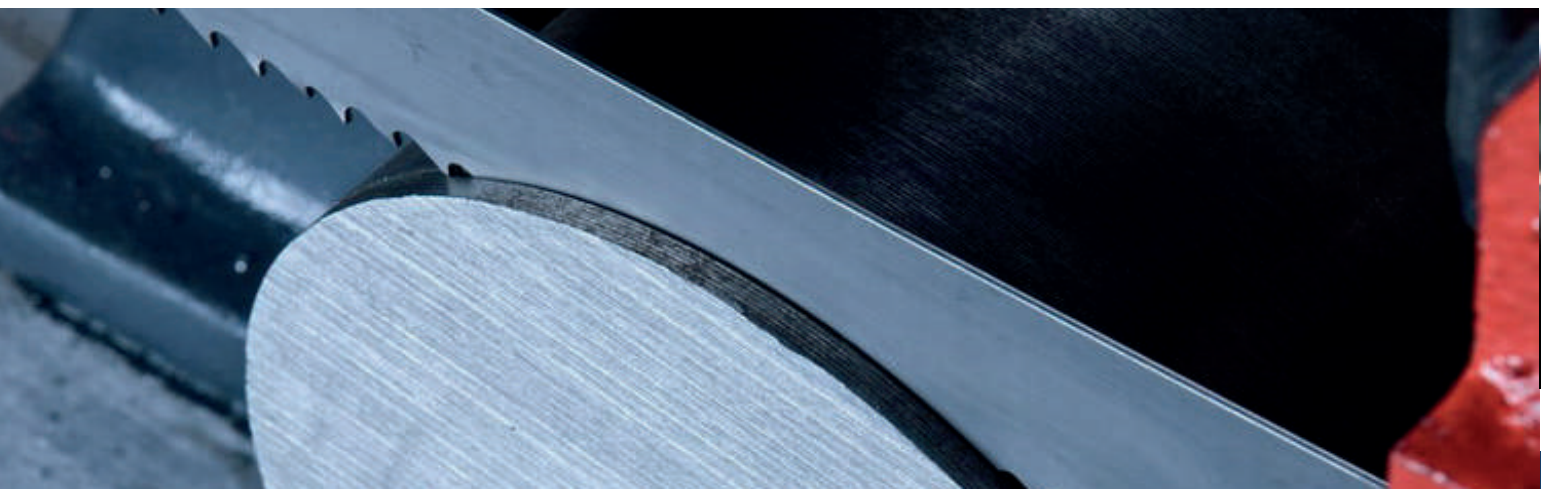





## Serras Tico-Tico

T-Shank Jig Saw Blades / Lames de Scie Sauteuse / Hojas de Sierra de Calar

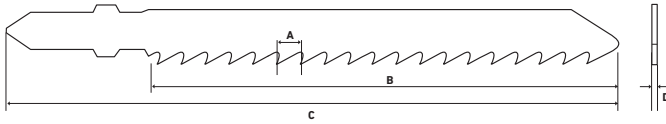

BI- METÁLICAS					HSS							
001521103001	001521103003	001521103007	001521103005	001521103008	001521102002	001521102001	001521102004	001521102003	001521102008	001521102009	001521102006	001521102005

	A	B	C	D	TPI
001521103001	2.0	50	75	2.5-6	12
001521103003	1.2	50	75	1-3	21
001521103007	4.0	75	100	5-50	6
001521103005	3.0	75	100	3-15	8
001521103008	2.5	75	100	3-30	10
001521102002	2.0	50	75	2.5-6	12
001521102001	1.2	50	75	1-3	21
001521102004	1.2	50	75	1-3	21
001521102003	0.8	50	75	0.5-1.5	32
001521102008	3.0	75	100	3-15	8
001521102009	3.0	75	100	3-15	8
001521102006	2.0	110	132	2.5-6	12
001521102005	1.2	110	132	1-3	21

	MATERIAIS / Materials / Matériaux / Materiales											
MADEIRA / Wood / Bois / Madera	○	○	●	●	●	●	●	●	●	●	●	●
MADEIRA COM PREGOS / Wood with nails / Bois avec clous / Madera con clavos	○	○	●	●	●	●	●	●	●	●	●	●
CONTRAPLACADO / Plywood / Contre-plaqué / Contraplacado	●	●	●	●	●	●	●	●	●	●	●	●
MELAMINA / Melamine / Mélamine / Melamina	●	○	●	●	●	●	●	●	●	●	●	●
AÇO, AÇO MACIO / Steel, Mild steel / Acier, Acier doux / Acero, Acero suave	●	●	●	●	●	●	●	●	●	●	●	●
CHAPAS METÁLICAS / Metal sheets / Feuilles Métalliques / Chapas Metálicas	●	●	●	●	●	●	●	●	●	●	●	●
ALUMÍNIO / Aluminium / Aluminium / Aluminio	●	●	●	○	●	●	●	●	●	●	●	●
METAIS NÃO FERROSOS / Non ferrous metals / Métaux non ferreux / Metales no ferrosos	●	●	●	○	●	●	●	●	●	●	●	●
PAINÉIS SANDWICH / Sandwich panels / Panneaux Sandwich / Paneles Sandwich	●	●	●	●	●	●	●	●	●	●	●	●
MATERIAIS SINTÉTICOS E PVC / PVC and synthetic materials / Matériaux synthétiques et PVC / Materiales sintéticos y PVC	○	○	●	●	●	●	●	●	●	●	●	●
ACRÍLICOS / Acrylic / Acryliques / Acrílicos	○	○	●	●	●	●	●	●	●	●	●	●
COURO, ESFEROVITE E CARTÃO / Leather, styrofoam and carton / Cuir, polystyrène et carton / Cuero, polixpan y cartón	●	●	●	●	●	●	●	●	●	●	●	●

	TIPO DE CORTE / Curved cut / Coupe courbe / Corte curvo											
PADRÃO DE CORTE RETO / Standard Straight cut / Modèle de coupe droit / Patrón de corte recto	●	●	●	●	●	●	●	●	○	○	○	●
CORTE CURVO / Curved cut / Coupe courbe / Corte curvo	●	●	●	●	●	●	○	●	●	●	●	●
CORTE FINO / Thin cut / Coupe fine / Corte fino	●	●	●	●	●	●	●	●	●	●	●	●
CORTE GROSSO / Thick cut / Coupe grossière / Corte grueso	●	●	○	●	●	●	●	●	●	●	●	●
CORTE RÁPIDO / Fast cut / Coupe rapide / Corte rápido	●	●	●	●	●	●	●	●	●	●	●	●

EMBALAGEM / Quantity / Emballage / Embalaje

5	5	5	5	5	5	5	5	5	5	5	5	5
---	---	---	---	---	---	---	---	---	---	---	---	---





# CORTE

Cut / Coupe / Corte

## DISCOS PASTILHADOS

TCT Saw Blades / Lames de Scie Circulaire / Discos Widia

### Disco Pastilhado p/ Corte Madeira

/ Wood TCG Circular Saw Blade / Lame de Scie Circulaire p/ Coupe Bois / Disco Widia p/ Corte Madera



- MADEIRA**  
/ Wood / Bois / Madera Excelente / Excellent / Excellent / Excelente
- MADEIRA**  
/ Wood / Bois / Madera Bom / Good / Bon / Bueno
- CONTRAPLACADO**  
/ Laminated / Contre-plaqué / Contraplacado Bom / Good / Bon / Bueno
- MELAMINA**  
/ Melamine / Mélamine / Melamina Bom / Good / Bon / Bueno

CÓDIGO CODE / CODE / CÓDIGO	DIMENSÕES SIZE / DIMENSIONS / MEDIDA	Nº DE DENTES Z Nº OF TEETH Z / NOMBRE DE DENTS Z / NÚMERO DE DIENTES Z	EMBALAGEM QUANTITY / EMBALLAGE / EMBALAJE
006172003036	200 x 30	36	1
006172503048	250 x 30	48	1
006172503060	250 x 30	60	1
006173003048	300 x 30	48	1
006173003072	300 x 30	72	1
006173003096	300 x 30	96	1
006173503054	350 x 30	54	1
006173503072	350 x 30	72	1
006174003060	400 x 30	60	1
006174003096	400 x 30	96	1

**Dentes com inclinação alternada (Esquerdo/Direito), indicado para uma utilização universal em madeira dura e macia, aglomerado e MDF**  
This disc has alternate ATB (Alternate Top Bevel) teeth configuration (right / left) and it was developed for use in all kinds of wood (soft and hard wood, laminated and MDF)  
Dents avec inclination alternée (Gauche/Droite), indiquées pour une utilisation universelle en bois dure et douce, aggloméré et MDF  
Dientes con inclinación alterna (Izquierda/Derecha), indicado para una utilización universal en madera dura y blanda, aglomerado y MDF

### Disco Pastilhado p/ Corte Melamina

/ Melamine TCG Circular Saw Blade / Lame de Scie Circulaire p/ Coupe Melamine / Disco Widia p/ Corte Melamina



- CONTRAPLACADO**  
/ Laminated / Contre-plaqué / Contraplacado Excelente / Excellent / Excellent / Excelente
- MADEIRA FOLHEADA**  
/ Wood veneer / Placage (bois) / Madera Chapada Excelente / Excellent / Excellent / Excelente
- MELAMINA**  
/ Melamine / Mélamine / Melamina Bom / Good / Bon / Bueno
- MADEIRA**  
/ Wood / Bois / Madera Bom / Good / Bon / Bueno

CÓDIGO CODE / CODE / CÓDIGO	DIMENSÕES SIZE / DIMENSIONS / MEDIDA	Nº DE DENTES Z Nº OF TEETH Z / NOMBRE DE DENTS Z / NÚMERO DE DIENTES Z	EMBALAGEM QUANTITY / EMBALLAGE / EMBALAJE
006162503060	250 x 30	60	1
006162503080	250 x 30	80	1
006163003072	300 x 30	72	1
006163003096	300 x 30	96	1

**Este disco tem os dentes trapezoidais com inclinação negativa**  
This disc has trapezoidal teeth with negative angle position  
La lame a des dents trapézoïdales avec inclination négative  
Este disco tiene los dientes trapezoidales con inclinación negativa





## DISCOS PASTILHADOS

TCT Saw Blades / Lames de Scie Circulaire / Discos Widia

### Disco Pastilhado p/ Corte Alumínio e Plástico

/ Aluminium / Plastic TCG Circular Saw Blade / Lame de Scie Circulaire p/ Coupe Aluminium et Plastique / Disco Widia p/ Corte Alumínio y Plástico



#### ALUMÍNIO

/ Aluminium / Aluminium / Aluminio

Excelente / Excellent / Excellent / Excelente



#### PLÁSTICO

/ Plastic / Plastique / Plástico

Excelente / Excellent / Excellent / Excelente

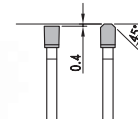
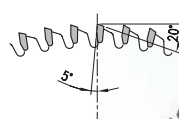

CÓDIGO CODE / CODE / CÓDIGO	DIMENSÕES SIZE / DIMENSIONS / MEDIDA	Nº DE DENTES Z Nº OF TEETH Z / NOMBRE DE DENTS Z / NÚMERO DE DIENTES Z	EMBALAGEM QUANTITY / EMBALLAGE / EMBALAJE
006142503080	250 x 30	80	1
006142503280	250 x 32	80	1
006143003096	300 x 30	96	1
006143003296	300 x 32	96	1
006143303010	330 x 30	102	1
006143503084	350 x 30	84	1
006143503098	350 x 30	108	1
006143503284	350 x 32	84	1
006143503298	350 x 32	108	1
006144003012	400 x 30	120	1
006144003212	400 x 32	120	1
006144503018	450 x 30	128	1
006144503218	450 x 32	128	1
006145003014	500 x 30	140	1
006145003214	500 x 32	140	1



Este disco tem os dentes alternados entre planos e trapezoidais com inclinação negativa

This disc has alternate teeth configuration (plane / trapezoidal) with negative angle position

La lame a des dents alternée entre planes et trapézoïdales avec inclinaison négative

Este disco tiene los dientes alternados entre planos y trapezoidales con inclinación negativa

### Disco Pastilhado Construção Civil p/ Serra Circular Portátil

/ TCG Circular Saw Blade for Building Construction - Portable Circular Saw / Lame de Scie Circulaire Construction Civile p/ Scie Circulaire Portable / Disco Widia Construcción Civil p/ Sierra Circular Portátil



#### PLÁSTICO

/ Plastic / Plastique / Plástico

Excelente / Excellent / Excellent / Excelente



#### MADEIRA C/ PREGOS

/ Wood with nails / Bois avec Clous / Madera c/Clavos

Excelente / Excellent / Excellent / Excelente

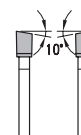
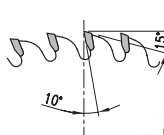

CÓDIGO CODE / CODE / CÓDIGO	DIMENSÕES SIZE / DIMENSIONS / MEDIDA	Nº DE DENTES Z Nº OF TEETH Z / NOMBRE DE DENTS Z / NÚMERO DE DIENTES Z	EMBALAGEM QUANTITY / EMBALLAGE / EMBALAJE
006151903024	190 x 30	24	1
006152353024	230 x 30	24	1
006152353034	235 x 30	34	1



Dentes com inclinação alternada (Esquerdo/Direito)

This disc has alternate ATB (Alternate Top Bevel) teeth configuration (right / left)

Dents avec inclinaison alternée (Gauche/Droite)

Dientes con inclinación alterna (Izquierda/Derecha)

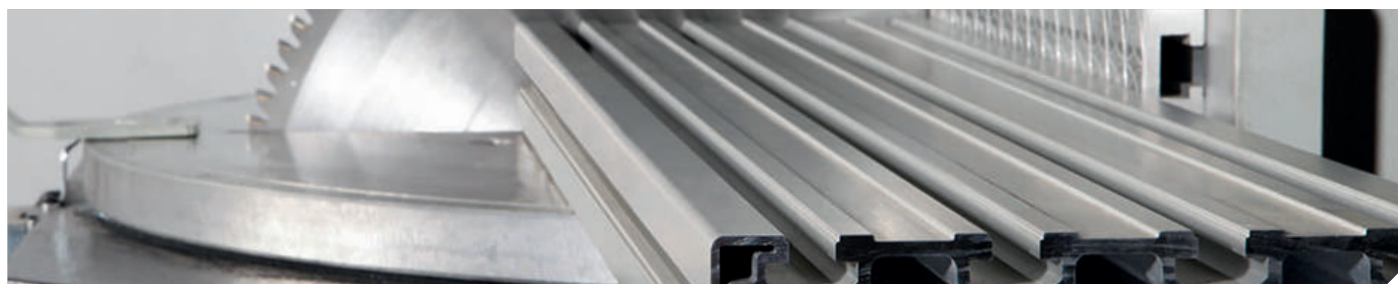



# CORTE

Cut / Coupe / Corte

## Escovas (Catrabuchas)

Cup and Wheel Brushes / Broses (Boisseaux) / Cepillos



**Ideal para a limpeza de superfícies grandes**  
Ideal for cleaning large surfaces  
Idéale pour nettoyage de grandes surfaces  
Ideal para limpeza de grandes superficies

### Escovas Copo em arame entrelaçado

/ Knotted Steel Wire - Cup / Brosse Boisseau à fils torsadés / Cepillos Copa de alambre trenzado

M14



**Aço temperado**  
/ Tempered Steel Wire  
/ Acier trempé  
/ Acero templado

CÓDIGO CODE / CODE / CÓDIGO	DIMENSÕES SIZE / DIMENSIONS / MEDIDA	ESPESSURA DO FIO WIRE THICKNESS / ÉPAISSEUR DU FIL / ESPESOR DEL HILO	EMBALAGEM QUANTITY / EMBALLAGE / EMBALAJE
001572000750	75 x 25	0.5	1
001572001250	125 x 25	0.5	1

### Escovas Copo em arame ondulado

/ Crimped Brass Coated Steel Wire - Cup / Brosse Boisseau à fils ondulés / Cepillos Copa de alambre ondulado

M14



**Aço latonado**  
/ Brass Coated Steel Wire  
/ Acier laitonné  
/ Acero latonado

CÓDIGO CODE / CODE / CÓDIGO	DIMENSÕES SIZE / DIMENSIONS / MEDIDA	ESPESSURA DO FIO WIRE THICKNESS / ÉPAISSEUR DU FIL / ESPESOR DEL HILO	EMBALAGEM QUANTITY / EMBALLAGE / EMBALAJE
001573000750	75 x 25	0.35	1
001573001250	125 x 33	0.35	1

### Escovas Circulares em arame entrelaçado

/ Knotted Steel Wire - Wheel / Brosse Circulaire à fils torsadés / Cepillos Circular de alambre trenzado

M14



**Aço temperado**  
/ Tempered Steel Wire  
/ Acier trempé  
/ Acero templado

CÓDIGO CODE / CODE / CÓDIGO	DIMENSÕES SIZE / DIMENSIONS / MEDIDA	ESPESSURA DO FIO WIRE THICKNESS / ÉPAISSEUR DU FIL / ESPESOR DEL HILO	EMBALAGEM QUANTITY / EMBALLAGE / EMBALAJE
001571001150	115x24	0.5	1



### Escovas Copo com haste

/ Crimped Brass Coated Steel Wire Cup brush with Shaft / Brosse Boisseau sur tige / Cepillos Copa con vástago

6 x 30



**Aço latonado**  
/ Brass Coated Steel Wire  
/ Acier laitonné  
/ Acero latonado

CÓDIGO CODE / CODE / CÓDIGO	DIMENSÕES SIZE / DIMENSIONS / MEDIDA	ESPESSURA DO FIO WIRE THICKNESS / ÉPAISSEUR DU FIL / ESPESOR DEL HILO	EMBALAGEM QUANTITY / EMBALLAGE / EMBALAJE
001574000500	50	0.35	1
001574000750	75	0.35	1

### Escovas Circulares com haste

/ Crimped Brass Coated Steel Wire Wheel brush with Shaft / Brosse Circulaire sur tige / Cepillos Circular con vástago

6 x 30



**Aço latonado**  
/ Brass Coated Steel Wire  
/ Acier laitonné  
/ Acero latonado

CÓDIGO CODE / CODE / CÓDIGO	DIMENSÕES SIZE / DIMENSIONS / MEDIDA	ESPESSURA DO FIO WIRE THICKNESS / ÉPAISSEUR DU FIL / ESPESOR DEL HILO	EMBALAGEM QUANTITY / EMBALLAGE / EMBALAJE
001573000750	75	0.35	1
001573001250	125	0.35	1



# DISCOS ABRASIVOS

ABRASIVE DISCS  
DISQUES ABRASIFS  
DISCOS ABRASIVOS



# DISCOS ABRASIVOS

Abrasive Discs / Disques Abrasifs / Discos Abrasivos

## Disco Corte Fino Premium - AÇO INOX

Flat Cutting Thin Wheels Premium - STAINLESS STEEL / Meules à Tronçonner fines Premium - ACIER INOX / Discos Corte Fino Premium - ACERO INOX

O Disco de Corte Fino Premium para aço inox é um produto especialmente formulado para cortar com excelentes resultados em aço inox, aços de liga, hardox e outros tipos de metais não ferrosos. É fabricado sem adição de ferro, enxofre ou cloro.

Funciona com todo o tipo de rebarbadoras, respeitando as velocidades periféricas recomendadas. Produzido com abrasivo e resinas de alta qualidade.

O disco tem um baixo coeficiente de fricção devido à sua fina espessura, reduzindo a produção de calor durante o corte, aumentando a velocidade de corte e uma perfeita estabilidade dinâmica do disco.

Com formato côncavo nos Ø 115 e Ø 125 confere maior segurança ao operador e melhora a performance devido à reduzida vibração do disco.

Tecnologia "Hydro Safe" – Protege o disco contra a humidade e previne o envelhecimento precoce do disco, mantendo as características de fábrica durante mais tempo. Hydro Safe proporciona maior longevidade otimizando o desempenho e a eficiência do disco.

The flat cutting thin wheel Premium for stainless steel is a multipurpose tool specially designed to cut stainless steel (inox) material, alloy steel and hardox. It is manufactured without addition of ferrous sulphurous and chlorinated fillers. It is suitable for angle grinders of all output levels.

Produced with abrasive and high quality resins. Lower friction coefficient due to the lower thickness, reducing the cut overheat, increasing the cut speed maintaining the dynamical stability of the disc.

The concave shape (Ø115 and Ø125) provides a superior safety to the operator and improves the performance due to low disk vibration. "Hydro Safe" Technology - protects the disc against moisture and prevents the premature aging of the disc, by keeping the factory default characteristics longer. Hydro Safe provides more longevity and optimizes the performance and the disc efficiency.

Les Meules à Tronçonner fines Premium pour acier inoxydable sont un produit spécialement formulé pour couper avec d'excellents résultats les aciers inoxydables, aciers alliés, hardox et d'autres métaux non ferreux.

Il est fabriqué sans addition de fer, du soufre ou du chlore. Il fonctionne avec tous les types de meuleuse, respectant les vitesses périphériques recommandées. Créé avec des abrasifs et des résines de hautes qualités.

Le disque a un faible coefficient de friction ce qui réduit la production de chaleur pendant la coupe, augmentant ainsi la vitesse de coupe et donnant une parfaite stabilité dynamique du disque.

Avec une forme concave en Ø115 et Ø 125 donne une plus grande sécurité à l'opérateur et améliore la performance dû à la réduite vibration du disque. Technologie "Hydro Safe" - protège le disque contre l'humidité et retarde le vieillissement du disque, maintenant les propriétés de neuf pendant plus longtemps. Hydro Safe augmente la durée de vie du disque et optimise ses performances.

El Disco de Corte Fino Premium para acero inox es un producto especialmente formulado para cortar con excelentes resultados en acero inoxidable, aceros aleados, hardox y otros tipos de metales no ferrosos. Está fabricado sin adición de hierro, azufre o cloro. Funciona con todo tipo de amoladoras, respetando las velocidades periféricas recomendadas. Fabricado con abrasivo y resinas de alta calidad. El disco tiene un bajo coeficiente de fricción, reduciendo la producción de calor durante el corte, aumentando la velocidad de corte y una perfecta estabilidad dinámica del disco.

Su forma cóncava en los discos de Ø 115 y Ø 125 confieren más seguridad al operario y mejora el rendimiento debido a la reducida vibración del disco. Tecnología "Hydro Safe" - Protege el disco contra la humedad y previene el envejecimiento prematuro del disco, manteniendo las características de fábrica durante más tiempo. Hydro Safe proporciona mayor longevidad optimizando el desempeño y la eficiencia del disco



Ø 230

Ø 180

Ø 125

Ø 115



CÓDIGO CODE / CODE / CÓDIGO	DIMENSÕES SIZE / DIMENSIONS / MEDIDA	EMBALAGEM QUANTITY / EMBALLAGE / EMBALAJE	QTD. PALETTE PALET / QT. PALETTE / CANT. PALÉ
007200021150	115 x 1.0 x 22.23	50	8000
007200021250	125 x 1.0 x 22.23	50	8000
007200021800	180 x 1.6 x 22.23	25	3000
007200022300	230 x 2.0 x 22.23	25	3000



Especialmente concebido para cortar aço inox, aços de liga, hardox e aços galvanizados | Indicado para o corte de chapas de aço, tubos, perfis e peças maciças

Especially conceived for cutting stainless steel and particular hard alloy steels as well as rust and acid proof steels, hardox, hardened steels, high alloy steels, high tensile steels and galvanized parts | Cutting of steel sheets, tubes, profiles and full materials

Conçu spécialement pour couper l'acier inoxydable, acier allié, hardox et acier galvanisé | Indiqué pour la coupe de feuilles en aciers, tuyaux, profilés et pièces massives  
Especialmente concebido para cortar acero inoxidable, aceros aleados, hardox y aceros galvanizados | Indicado para el corte de placas de acero, tubos, perfiles y piezas macizas

## Disco Corte Fino Premium - AÇO

Flat Cutting Thin Wheels Premium - STEEL / Meules à Tronçonner fines Premium - ACIER / Discos Corte Fino Premium - ACERO

CÓDIGO CODE / CODE / CÓDIGO	DIMENSÕES SIZE / DIMENSIONS / MEDIDA	EMBALAGEM QUANTITY / EMBALLAGE / EMBALAJE	QTD. PALETTE PALET / QT. PALETTE / CANT. PALÉ
007200021151	115 x 1.3 x 22.23	25	8000
007200021251	125 x 1.3 x 22.23	25	8000
007200021801	180 x 2.0 x 22.23	25	3000
007200022301	230 x 2.0 x 22.23	25	3000



**Para cortar ferro, aço, aços de elevada dureza, hardox, aços estruturais, peças galvanizadas | Ideal para cortar tubos de canalização, perfis metálicos para gesso cartonado, chapas metálicas e peças sólidas em aço**

*For cutting iron, steel, high tensile steels, hardox, structural steels, galvanized parts | Cutting of thin-walled tubes, thin-walled profiles, steel sheets, solid material and flat iron*  
*Pour couper le fer, acier, acier de haute dureté, hardox, acier structurel, pièces galvanisées | Idéale pour couper des tuyaux de canalisation, profilés métalliques pour plâtre cartoné, feuilles métalliques et pièces solides en acier*

*Para cortar hierro, acero, aceros de elevada dureza, hardox, aceros estructurales, piezas galvanizadas | Ideal para cortar tuberías, perfiles metálicos para placas de yeso laminado, chapas metálicas y piezas sólidas en acero*



## Disco Corte Fino Premium Dynamic - AÇO INOX

Flat Cutting Thin Wheels Premium Dynamic - Stainless steel / Meules à Tronçonner fines Premium Dynamic - Acier Inox / Discos Corte Fino Premium Dynamic - ACERO INOX

CÓDIGO CODE / CODE / CÓDIGO	DIMENSÕES SIZE / DIMENSIONS / MEDIDA	EMBALAGEM QUANTITY / EMBALLAGE / EMBALAJE	QTD. PALETTE PALET / QT. PALETTE / CANT. PALÉ
007200021152	115 x 1.0 x 22.23	50	8000
007200021252	125 x 1.0 x 22.23	50	8000
007200021802	180 x 1.5 x 22.23	25	3000
007200022302	230 x 1.9 x 22.23	25	3000



**Especialmente concebido para cortar aço inox, aços de liga, hardox e aços galvanizados | Indicado para o corte de chapas de aço, tubos, perfis e peças maciças**

*Especially conceived for cutting stainless steel and particular hard alloy steels as well as rust and acid proof steels, hardox, hardened steels, high alloy steels, high tensile steels and galvanized parts | Cutting of steel sheets, tubes, profiles and full materials*

*Conçu spécialement pour couper l'acier inoxydable, acier allié, hardox et acier galvanisé | Indiqué pour la coupe de feuilles en aciers, tuyaux, profilés et pièces massives*  
*Especialmente concebido para cortar acero inoxidable, aceros aleados, hardox y aceros galvanizados | Indicado para el corte de placas de acero, tubos, perfiles y piezas macizas*

## PREMIUM DYNAMIC



## Disco Corte Fino Premium Dynamic - AÇO

Flat Cutting Thin Wheels Premium Dynamic - STEEL / Meules à Tronçonner fines Premium Dynamic - ACIER / Discos Corte Fino Premium Dynamic - ACERO

CÓDIGO CODE / CODE / CÓDIGO	DIMENSÕES SIZE / DIMENSIONS / MEDIDA	EMBALAGEM QUANTITY / EMBALLAGE / EMBALAJE	QTD. PALETTE PALET / QT. PALETTE / CANT. PALÉ
007200021153	115 x 1.0 x 22.23	50	8000
007200021253	125 x 1.0 x 22.23	50	8000
007200021803	180 x 1.5 x 22.23	25	3000
007200022303	230 x 1.9 x 22.23	25	3000



**Para cortar ferro, aço, aços de elevada dureza, hardox, aços estruturais, peças galvanizadas | Ideal para cortar tubos de canalização, perfis metálicos para gesso cartonado, chapas metálicas e peças sólidas em aço**

*For cutting iron, steel, high tensile steels, hardox, structural steels, galvanized parts | Cutting of thin-walled tubes, thin-walled profiles, steel sheets, solid material and flat iron*  
*Pour couper le fer, acier, acier de haute dureté, hardox, acier structurel, pièces galvanisées | Idéale pour couper des tuyaux de canalisation, profilés métalliques pour plâtre cartoné, feuilles métalliques et pièces solides en acier*

*Para cortar hierro, acero, aceros de elevada dureza, hardox, aceros estructurales, piezas galvanizadas | Ideal para cortar tuberías, perfiles metálicos para placas de yeso laminado, chapas metálicas y piezas sólidas en acero*

## PREMIUM DYNAMIC





# DISCOS ABRASIVOS

Abrasive Discs / Disques Abrasifs / Discos Abrasivos

## Discos Corte Fino Special - AÇO INOX

Flat Cutting Thin Wheels Special - Stainless steel / Meules à Tronçonner fines Special - Acier Inox / Disco Corte Fino Special - ACERO INOX



CÓDIGO CODE / CODE / CÓDIGO	DIMENSÕES SIZE / DIMENSIONS / MEDIDA	MÁX RPM MAX RPM / MAX RPM / MÁX RPM	EMBALAGEM QUANTITY / EMBALLAGE / EMBALAJE	QTD. PALETTE PALET / QT. PALETTE / CANT. PALÉ
007200011150	115 x 1 x 22.23	...	50	8000
007200011250	125 x 1 x 22.23	...	50	8000
007200161800	180 x 1.9 x 22.23	...	25	3000
007200192300	230 x 2.0 x 22.23	...	25	3000



Para cortar aço inox, aço, aços de elevada dureza, aços de liga e peças galvanizadas | Ideal para cortar tubos de canalização, perfis metálicos para gesso cartonado, chapas metálicas e peças sólidas em aço

For cutting stainless steel, steel, high hardness steels, alloy steels and galvanised parts | Ideal for cutting piping tubes, metal profiles for plasterboard, metal sheets and solid steel parts  
Pour couper l'acier inoxydable, l'acier, les aciers à haute dureté, les aciers alliés et les pièces galvanisées | Idéal pour couper les tuyaux de plomberie, profilés métalliques pour les plaques de plâtre, tôles métalliques et pièces solides en acier

Para cortar acero inoxidable, acero, aceros de alta dureza, aceros aleados y piezas galvanizadas | Ideal para cortar tubos de canalización, perfiles metálicos para yeso cartonado, chapas metálicas y piezas sólidas de acero

## Discos Corte Fino Classic Plus - AÇO INOX

Flat Cutting Thin Wheels Classic Plus - Stainless steel / Meules à Tronçonner fines Classic Plus - Acier Inox / Disco Corte Fino Classic Plus - ACERO INOX



CÓDIGO CODE / CODE / CÓDIGO	DIMENSÕES SIZE / DIMENSIONS / MEDIDA	MÁX RPM MAX RPM / MAX RPM / MÁX RPM	EMBALAGEM QUANTITY / EMBALLAGE / EMBALAJE	QTD. PALETTE PALET / QT. PALETTE / CANT. PALÉ
007200011153	115 x 1 x 22.23	...	50	20000
007200011253	125 x 1 x 22.23	...	50	20000
007200161803	180 x 1.6 x 22.23	...	25	5200
007200192303	230 x 1.9 x 22.23	...	25	3150



Corte de aço inox, aço e peças galvanizadas | Ideal para cortar tubos de canalização, perfis metálicos para gesso cartonado, chapas metálicas e peças sólidas em aço

Cutting of stainless steel, steel and galvanised parts | Ideal for cutting piping tubes, metal profiles for plasterboard, metal sheets and solid steel parts

Coupe d'acier inoxydable, d'acier et de pièces galvanisées | Idéal pour couper les tuyaux de plomberie, profilés métalliques pour les plaques de plâtre, tôles métalliques et pièces solides en acier

Corte de acero inoxidable, acero y piezas galvanizadas | Ideal para cortar tubos de canalización, perfiles metálicos para yeso cartonado, chapas metálicas y piezas sólidas de acero

## Discos Corte Fino Classic - AÇO INOX

Flat Cutting Thin Wheels Classic - Stainless steel / Meules à Tronçonner fines Classic - Acier Inox / Disco Corte Fino Classic - ACERO INOX



CÓDIGO CODE / CODE / CÓDIGO	DIMENSÕES SIZE / DIMENSIONS / MEDIDA	MÁX RPM MAX RPM / MAX RPM / MÁX RPM	EMBALAGEM QUANTITY / EMBALLAGE / EMBALAJE	QTD. PALETTE PALET / QT. PALETTE / CANT. PALÉ
006800011150	115 x 1 x 22.23	...	50	9950
006800011250	125 x 1 x 22.23	...	50	9950
006800021800	180 x 2 x 22.23	...	25	-
006800022300	230 x 1.9 x 22.23	...	25	2000



Corte de aço inox, aço e peças galvanizadas | Ideal para cortar tubos de canalização, perfis metálicos para gesso cartonado, chapas metálicas e peças sólidas em aço

Cutting of stainless steel, steel and galvanised parts | Ideal for cutting piping tubes, metal profiles for plasterboard, metal sheets and solid steel parts

Coupe d'acier inoxydable, d'acier et de pièces galvanisées | Idéal pour couper les tuyaux de plomberie, profilés métalliques pour les plaques de plâtre, tôles métalliques et pièces solides en acier

Corte de acero inoxidable, acero y piezas galvanizadas | Ideal para cortar tubos de canalización, perfiles metálicos para yeso cartonado, chapas metálicas y piezas sólidas de acero





## Disco de Corte Aço Premium

Cutting-off Wheels (for Metal) Premium / Meules à Tronçonner Acier Premium / Disco de Corte Acero Premium

CÓDIGO CODE / CODE / CÓDIGO	DIMENSÕES SIZE / DIMENSIONS / MEDIDA	MÁX RPM MAX RPM / MAX RPM / MÁX RPM	EMBALAGEM QUANTITY / EMBALLAGE / EMBALAJE	QTD. PALETE PALET / QT. PALETTE / CANT. PALÉ
007200331150	115 x 2.5 x 22.23	13300	25	8000
007200331250	125 x 2.5 x 22.23	12250	25	8000
007200332300	230 x 3.2 x 22.23	6600	25	3000



Usar preferencialmente em máquinas pneumáticas e rebarbadoras elétricas com a potência adequada | Na produção do disco foram utilizados abrasivos de elevada qualidade sem qualquer adição de ferro sulfúreo e aglomerantes com cloro | Os discos são apropriados para o corte de ferro fundido, aço, tubos e perfis, chapa de aço, chapas de aço estrutural e aço maciço

Preferably for use on high powered pneumatic and electric angle grinders | The wheels containing a high quality abrasive manufactured without addition of ferrous sulphurous, and chlorinated fillers | The wheels are particularly suitable to cut cast iron, steel, thin walled tubes and profiles, steel sheets, flat iron, structural steel sheets and solid materials

Utiliser de préférence dans des machines pneumatiques et des meuleuses électriques avec une puissance adéquate | Dans la fabrication du disque, des abrasifs de haute qualité ont été utilisés sans aucune addition de fer sulfurés et d'agglomérants avec du chlore | Les disques sont préparés pour couper de la fonte, acier, tuyaux et profilés, tôles en acier, plaques en acier de construction et de l'acier massif

Usar preferentemente en máquinas neumáticas y amoladoras eléctricas con la potencia adecuada | En la producción del disco han sido utilizados abrasivos de elevada calidad sin cualquier adición de hierro sulfuro y aglomerantes con cloro | Los discos son apropiados para el corte de hierro fundido, acero, tubos y perfiles, chapa de acero, chapas de acero estructural y acero macizo

## Disco de Corte Aço Classic

Cutting-off Wheels (for Metal) Classic / Meules à Tronçonner Acier Classic / Disco de Corte Acero Classic

CÓDIGO CODE / CODE / CÓDIGO	DIMENSÕES SIZE / DIMENSIONS / MEDIDA	MÁX RPM MAX RPM / MAX RPM / MÁX RPM	EMBALAGEM QUANTITY / EMBALLAGE / EMBALAJE	QTD. PALETE PALET / QT. PALETTE / CANT. PALÉ
007200031150	115 x 3.2 x 22.23	13300	25	...
007200321250	125 x 3.2 x 22.23	12250	25	...
007200321800	180 x 3.2 x 22.23	8500	25	...
007200322300	230 x 3.2 x 22.23	6600	25	...



Corte de aço, chapas de aço e aço maciço | Pode ser usado em qualquer tipo de rebarbadora

Cutting off metal, sheet profile and solid materials | Suitable for angle grinders of all output levels  
Couper d'acier, de plaques d'acier et d'acier massif | Il peut être utilisé en toutes sortes de meuleuse

Corte de acero, chapas de acero y acero macizo | Puede ser usado en cualquier tipo de amoladora

## Disco de Rebarbar Aço Premium

Grinding Wheels Premium / Meule à Ébarber Premium / Discos de Desbaste Premium

CÓDIGO CODE / CODE / CÓDIGO	DIMENSÕES SIZE / DIMENSIONS / MEDIDA	MÁX RPM MAX RPM / MAX RPM / MÁX RPM	EMBALAGEM QUANTITY / EMBALLAGE / EMBALAJE
007200651150	115 x 6.5 x 22.23	13300	10
007200651250	125 x 6.5 x 22.23	12250	10
007200651800	180 x 7.0 x 22.23	8500	10
007200652300	230 x 7.0 x 22.23	6600	10



Especialmente desenvolvido para polir soldaduras, nivelar chanfros, rebarbar, polimento de superfícies e esquadrias | Usar preferencialmente em máquinas pneumáticas e rebarbadoras com a potência adequada

Specially conceived for grinding on weld seams, levelling chamfers, deburring, edge and surface grindings | Preferably for use on high powered pneumatic and electric angle grindings

Spécialement développées pour polir soudages, niveler chanfreins, ébarber, polir surfaces et équerres | Utiliser, de préférence, sur machines pneumatiques et meuleuses avec puissance adéquate

Especialmente desarrollado para pulir soldaduras, nivelar biselados, desbarbar, pulido de superficies y escuadras | Usar preferentemente en máquinas neumáticas y amoladoras con la potencia adecuada

## Disco de Rebarbar Aço Classic

Grinding Wheels Classic / Meule à Ébarber Classic / Discos de Desbaste Classic

CÓDIGO CODE / CODE / CÓDIGO	DIMENSÕES SIZE / DIMENSIONS / MEDIDA	MÁX RPM MAX RPM / MAX RPM / MÁX RPM	EMBALAGEM QUANTITY / EMBALLAGE / EMBALAJE
007200641150	115 x 7.0 x 22.23	13300	10
007200641250	125 x 7.0 x 22.23	12250	10
007200641800	180 x 7.0 x 22.23	8500	10
007200642300	230 x 7.0 x 22.23	6600	10



Polimento de superfícies, desbaste de soldaduras, chanfros, rebarbar cordões de soldadura em esquadrias | Pode ser usado em qualquer tipo de rebarbadora

Surface grinding, work on weld seams, chamfering, deburring, fillet weld grinding | Suitable for use on angle grinders of all output categories

Poliissage de surfaces, ébavurage de soudage, chanfreins, ébarber cordons de soudure sur équerres | Peut être utiliser sur n'importe quel type de meuleuse  
Pulido de superficies, desbaste de soldaduras, biselados, desbarbar cordones de soldadura en escuadras | Puede ser usado en cualquier tipo de amoladora



# DISCOS ABRASIVOS

Abrasive Discs / Disques Abrasifs / Discos Abrasivos

## Disco de Lamelas Premium

Flap Disc Premium / Disque à Lamelles Premium / Discos de Láminas Premium

### DISCOS DE LAMELAS LONG LIFE PREMIUM

/ FLAP DISC LONG LIFE PREMIUM / DISQUE À LAMELLES LONG LIFE PREMIUM / DISCOS DE LÁMINAS LONG LIFE

CÓDIGO CODE / CODE / CÓDIGO	DIÂMETROS DIAMETERS / DIAMÈTRES / DIÁMETROS	GRÃO GRITS / GRAIN / GRANO	MÁX RPM MAX RPM / MAX RPM / MÁX RPM	EMBALAGEM QUANTITY / EMBALLAGE / EMBALAJE
007514115040	115	40	13200	10
007514115060	115	60	13200	10
007514115080	115	80	13200	10
007514115120	115	120	13200	10
007514125040	125	40	12200	10
007514125060	125	60	12200	10
007514125080	125	80	12200	10
007514125120	125	120	12200	10



#### ATÉ 2H DE TRABALHO CONTÍNUO

/ Up to two hours of continuous work / Jusqu'à deux heures de travail continu / Hasta dos horas de trabajo continuo

### DISCOS DE LAMELAS MULTISUPERFÍCIES PREMIUM

/ FLAP DISC MULTISUPERFÍCIES PREMIUM / DISQUE À LAMELLES MULTISUPERFÍCIES PREMIUM / DISCOS DE LÁMINAS MULTISUPERFÍCIES

CÓDIGO CODE / CODE / CÓDIGO	DIÂMETROS DIAMETERS / DIAMÈTRES / DIÁMETROS	GRÃO GRITS / GRAIN / GRANO	MÁX RPM MAX RPM / MAX RPM / MÁX RPM	EMBALAGEM QUANTITY / EMBALLAGE / EMBALAJE
007514115041	115	40/60	13200	10
007514125041	125	40/60	13200	10



#### LIXA MULTIGRÃO (40/60) PARA DESBASTE E ACABAMENTO

/ Multigrain abrasive for roughing and finishing / Abrasif multigrain pour l'ébauche et la finition / Lija multigrano para desbaste y acabado

### DISCOS DE LAMELAS TORNADO PREMIUM

/ FLAP DISC TORNADO PREMIUM / DISQUE À LAMELLES TORNADO PREMIUM / DISCOS DE LÁMINAS TORNADO

CÓDIGO CODE / CODE / CÓDIGO	DIÂMETROS DIAMETERS / DIAMÈTRES / DIÁMETROS	GRÃO GRITS / GRAIN / GRANO	MÁX RPM MAX RPM / MAX RPM / MÁX RPM	EMBALAGEM QUANTITY / EMBALLAGE / EMBALAJE
007514115042	115	40	12200	10
007514115043	115	60	12200	10
007514125042	125	40	12200	10
007514125043	125	60	12200	10



#### REMOVE ATÉ 1KG DE AÇO EM 20 MINUTOS

/ Removes up to 1 kg steel in 20 minutes / Il supprime jusqu'à 1 kg d'acier dans 20 minutes / Elimina hasta 1 kg de acero en 20 minutos

#### LONG LIFE

#### MULTISUPERFÍCIES



#### TORNADO



#### Soluções de alta performance para polimento de aço e aço inox

High performance solutions for polishing of steel and stainless steel

Solutions hautes performances pour le polissage de l'acier et acier inoxydable

Soluciones de alto rendimiento para el pulido de acero y acero inoxidable



## DISCO DE LAMELAS LONG LIFE PREMIUM

- Para aço inox A2 (304 e 308) e A4 (316): Elevada taxa de remoção sem sobreaquecer as peças;
- Até 2 horas de trabalho contínuo;
- Autodesgaste do prato para usar até ao último grão;
- 100% Zircônio com agentes de arrefecimento;
- Extremamente seguro e amigo do ambiente.

### FLAP DISC LONG LIFE PREMIUM

- For A2 (304 and 308) and A4 (316) stainless steel: High rate of removal without overheating the parts;
- 2 hours of continuous grinding;
- Self-trimming, grind to the last millimeter;
- 100% Zirconium with cooling agents;
- Completely safe and helps the environment.

### DISQUE À LAMELLES LONG LIFE PREMIUM

- Pour acier inox A2 (304 et 308) et A4 (316): Taux élevé de dépose sans surchauffer les pièces;
- Jusqu'à 2h de travail continu;
- Autodégradation du plateau pour utilisé jusqu'au dernier grain;
- 100% Zirconium avec des agents de refroidissement;
- Extrêmement sûr et ami de l'environnement.

### DISCOS DE LÁMINAS LONG LIFE PREMIUM

- Para acero inox A2(304 y 308) y A4(316): Alta tasa de extracción sin sobrecalentamiento de las piezas;
- Hasta 2 horas de trabajo continuo;
- Autodesgaste del plato para usar hasta al último grano;
- 100% de circonio con agentes de refrigeración;
- Extremadamente seguro y respetuoso con el medio ambiente.



**2 HORAS**  
**POLIMENTO**  
/ 2 HOURS POLISH  
/ 2 HEURES POLISSAGE  
/ 2 HORAS PULIDO

Aço inoxidável  
Stainless steel /  
Acier inoxydable /  
Acero inoxidable



DURABILIDADE | PERFORMANCE / Durability | Performance / Durabilité | Performances / Durabilidad | Rendimiento

## DISCO DE LAMELAS MULTISUPERFÍCIES PREMIUM

- Lixa de Cerâmica Multigrão (40/60): Para todo o tipo de metais;
- Elevada taxa de remoção de material apenas com um tipo de grão;
- Autodesgaste do prato para usar até ao último grão;
- Baixo ruído e vibração e pouco aquecimento do disco devido ao desbaste a baixa temperatura;
- Ecológico e de fácil eliminação, amigo do ambiente.

### FLAP DISC ALL METALS PREMIUM

- Multi grain ceramic abrasive (40/60): For all type of metals;
- Very aggressive stock removal with just one grit size;
- Self-trimming, grind to the last millimeter;
- Vibration, heat and noise reduced due to low temperature self-grinding;
- Easy waste disposal. Helps environment.

### DISQUE À LAMELLES MULTISURFACES PREMIUM

- Abrasif multigrain en céramique (40/60): Pour tous types de métaux;
- Taux élevé de retrait de matériel à peine avec un type de grain;
- Autodégradation du plateau pour l'utiliser jusqu'au dernier grain;
- Moins de bruit et vibration et peu de chauffe du disque à ébavurage à basse température;
- Ecologique et de facile élimination, ami de l'environnement.

### DISCOS DE LÁMINAS MULTISUPERFÍCIES PREMIUM

- Lixa de cerâmica multigrano (40/60): Para todo tipo de metais;
- Elevada tasa de eliminación de material solamente con un tipo de grano;
- Autodesgaste del plato para usar hasta al último grano;
- Bajo ruido y vibración y poco calentamiento del disco debido a la operación de mecanizado a baja temperatura;
- Ecológico y de fácil eliminación y respetuoso con el medio ambiente.



**MULTI**  
**MATERIAIS**  
/ MULTI-MATERIALS  
/ MULTI-MATIÈRES  
/ MULTI MATERIAL

Aço  
Steel /  
Acier /  
Acero

Alumínio  
Aluminium /  
Aluminium /  
Aluminio

Bronze  
Brass /  
Bronze /  
Bronce

Titânio  
Titanium /  
Titane /  
Titanio

DESBASTE AGRESSIVO | MULTI MATERIAIS / Thinning aggressive | Multi-material / L'éclaircie agressif | multi-matières / Adelgazamiento | Multi-material agresivo

## DISCO DE LAMELAS TORNADO PREMIUM

- Para aço: Remove até 1kg de material em 20 min;
- Elevada taxa de remoção de material com baixa vibração, calor e ruído;
- Auto Desgaste do prato para usar até ao último grão;
- 100% Zircónio híbrido com agentes de arrefecimento;
- Ecológico.

### FLAP DISC TORNADO PREMIUM

- For steel: Removes up to 1kg of material in 20 min;
- High material removal rate with low vibration, heat and noise;
- Self-trimming, grind to the last millimeter;
- 100% Zirconium hybrid with cooling agents;
- Ecological.

### DISQUE À LAMELLES TORNADE PREMIUM

- Pour l'acier: Supprime jusqu'à 1kg de matériau en 20 min;
- Taux d'enlèvement de matériel élevé avec peu de vibrations, bruit et chaleur;
- Usure automatique de plat pour utilisation jusqu'à la dernier grain;
- 100% Zirconium hybride avec des agents de refroidissement;
- Ecologique.

### DISCOS DE LÁMINAS TORNADO PREMIUM

- Para acero: Elimina hasta 1kg de material en 20min.;
- Elevada tasa de eliminación de materiales con poca vibración, calor y ruido;
- Autodesgaste del plato para usar hasta al último grano;
- 100% híbrido de circonio con agentes refrigerantes;
- Ecológico.



**REMOVE ATÉ**  
**1 KG** DE AÇO  
**EM 20 MINUTOS!!\***  
/ REMOVES UP TO 1 KG STEEL IN 20 MINUTES!!  
/ IL SUPPRIME JUSQU'À 1 KG D'ACIER DANS 20 MINUTES !!  
/ ELIMINA HASTA 1 KG DE ACERO EN 20 MINUTOS!!

Aço  
Steel /  
Acier /  
Acero

DESBASTE RÁPIDO | AÇO / Rapid thinning | Steel / Amincissement rapide | Acier / rápido adelgazamiento | Acero

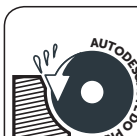

**Auto Desgaste do prato para usar até ao último grão.**  
Self-trimming, grind to the last millimeter / Usure automatique de plat pour utilisation jusqu'à la dernier grain / Autodesbaste del plato para utilizar hasta el último grano





# DISCOS ABRASIVOS

Abrasive Discs / Disques Abrasifs / Discos Abrasivos

## Disco de Lamelas Zircónio Special

Zirconium Flap Disc Special / Disque à Lamelles Zirconium Special / Discos de Láminas Circonio Special



CÓDIGO CODE / CODE / CÓDIGO	DIÂMETROS DIAMETERS / DIAMÈTRES / DIÁMETROS	GRÃO GRITS / GRAIN / GRANO	EMBALAGEM QUANTITY / EMBALLAGE / EMBALAJE
007524115040	115	40	10
007524115060	115	60	10
007524115080	115	80	10
007524115120	115	120	10
007524125040	125	40	10
007524125060	125	60	10
007524125080	125	80	10
007524125120	125	120	10



**Para desbaste de cordões de soldadura e esquadrias em aço inox e aço**

*To work on weld seams, chamfering surface grinding on stainless steel and steel*

*Pour ébavurage de cordons de soudure et équerres en acier et inox*

*Para desbaste de cordones de soldadura y escuadras en acero inox y acero*

## Disco de Lamelas Zircónio Classic

Zirconium Flap Disc Classic / Disque à Lamelles Zirconium Classic / Discos de Láminas Circonio Classic



CÓDIGO CODE / CODE / CÓDIGO	DIÂMETROS DIAMETERS / DIAMÈTRES / DIÁMETROS	GRÃO GRITS / GRAIN / GRANO	EMBALAGEM QUANTITY / EMBALLAGE / EMBALAJE
007534115040	115	40	10
007534115060	115	60	10
007534115080	115	80	10
007534115120	115	120	10
007534125040	125	40	10
007534125060	125	60	10
007534125080	125	80	10
007534125120	125	120	10



**Para desbaste de cordões de soldadura e esquadrias em aço inox e aço**

*To work on weld seams, chamfering surface grinding on stainless steel and steel*

*Pour ébavurage de cordons de soudure et équerres en acier et inox*

*Para desbaste de cordones de soldadura y escuadras en acero inox y acero*



## Disco de Lixa

Flexible Fibre Discs / Disque Abrasif / Disco de Lija

### DISCOS DE LIXA ÓXIDO ALUMÍNIO / FLEXIBLE FIBRE DISCS ALUMINIUM OXIDE / DISQUE ABRASIF OXYDE D'ALUMINIUM / DISCO DE LIXA ÓXIDO ALUMÍNIO

CÓDIGO CODE / CODE / CÓDIGO	DIÂMETROS DIAMETERS / DIAMÈTRES / DIAMETROS	GRÃO GRITS / GRAIN / GRANO	EMBALAGEM QUANTITY / EMBALLAGE / EMBALAJE
007300241150	115	24	50
007300361150	115	36	50
007300501150	115	50	50
007300601150	115	60	50
007300801150	115	80	50
007301001150	115	100	50
007301201150	115	120	50

### DISCOS DE LIXA ZIRCÔNIO / FLEXIBLE FIBRE DISCS ALUMINA ZIRCONIA / DISQUE ABRASIF ZIRCONNE / DISCO DE LIXA ZIRCONIO

CÓDIGO CODE / CODE / CÓDIGO	DIÂMETROS DIAMETERS / DIAMÈTRES / DIAMETROS	GRÃO GRITS / GRAIN / GRANO	EMBALAGEM QUANTITY / EMBALLAGE / EMBALAJE
007310241150	115	24	50
007310361150	115	36	50
007310501150	115	50	50
007310601150	115	60	50
007310801150	115	80	50
007311001150	115	100	50
007311201150	115	120	50

### DISCOS DE LIXA CARBONETO DE SILÍCIO / FLEXIBLE FIBRE DISCS SILICON CARBIDE / DISQUE ABRASIF CARBURE DE SILICIUM / DISCO DE LIXA CARBURO DE SILÍCIO

CÓDIGO CODE / CODE / CÓDIGO	DIÂMETROS DIAMETERS / DIAMÈTRES / DIAMETROS	GRÃO GRITS / GRAIN / GRANO	EMBALAGEM QUANTITY / EMBALLAGE / EMBALAJE
007320361150	115	36	50
007320501150	115	50	50
007320601150	115	60	50
007320801150	115	80	50
007321001150	115	100	50
007321201150	115	120	50

### PRATO ADAPTADOR / BACKING PAD / PLATEAU ADAPTATEUR / PLATO ADAPTADOR

CÓDIGO CODE / CODE / CÓDIGO	DIÂMETROS DIAMETERS / DIAMÈTRES / DIAMETROS	EMBALAGEM QUANTITY / EMBALLAGE / EMBALAJE
007300001150	115	1



**Excelente performance no desbaste agressivo e limpeza de peças metálicas, rebarbar e polir soldaduras e remoção de riscos. Os discos de lixa são indicados para trabalhos de acabamento em peças metálicas.**

Outstanding for rough grinding and sanding de-rusting metal parts, deburring and grinding welded seams and removing scratches. These discs are also suitable for precision finishing work metals.

Excellente performance dans l'ébavurage agressif et nettoyage des pièces métalliques, ébarbage et polissage de soudures et retrait de rayures. Les disques abrasifs sont indiqués pour les travaux de finition en pièces métalliques.

Excelente rendimiento en el desbaste agresivo y limpieza de piezas metálicas, desbarbar y pulir soldaduras y eliminación de rayas. Los discos de lija están indicados para trabajos de acabados en piezas metálicas.

## Discos de Lixa com Velcro

Abrasive Disc with Velcro Tape / Disques Abrasifs avec Velcro / Discos de Lija con Velcro

### ALUMINIUM OXIDE ABRASIVE DISC / DISQUE D'OXYDE D'ALUMINIUM / DISCO DE ÓXIDO ALUMÍNIO / DISCO DE ÓXIDO ALUMÍNIO

CÓDIGO CODE / CODE / CÓDIGO	DIÂMETROS DIAMETERS / DIAMÈTRES / DIAMETROS	GRÃO GRITS / GRAIN / GRANO	EMBALAGEM QUANTITY / EMBALLAGE / EMBALAJE
007520360115	115	36	25
007520500115	115	50	25
007520600115	115	60	25
007520800115	115	80	25
007521200115	115	120	25
007522200115	115	220	25



**Decapagem de tintas, remoção de ferrugens e oxidações, limpeza de superfícies | Ideal para serralharias.**

Ink removal, dust and oxidation removal, surface cleaning | Ideal for metal industry.

Décapage de peintures, retrait de rouille et oxydations, nettoyage de surfaces | Idéal pour serrureries.

Decapado de pinturas, eliminación de herrumbres y oxidaciones, limpieza de superficies | Ideal para serrallerías.

### SILICON CARBIDE ABRASIVE DISC / DISQUE DE CARBURE DE SILICIUM / DISCO DE CARBURO DE SILÍCIO / DISCO DE CARBONETO DE SILÍCIO

CÓDIGO CODE / CODE / CÓDIGO	DIÂMETROS DIAMETERS / DIAMÈTRES / DIAMETROS	GRÃO GRITS / GRAIN / GRANO	EMBALAGEM QUANTITY / EMBALLAGE / EMBALAJE
007530360115	115	36	25
007530500115	115	50	25
007530600115	115	60	25
007530800115	115	80	25
007531200115	115	120	25
007532200115	115	220	25
007330150060	150	60	25
007330150080	150	80	25
007330150120	150	120	25
007330150180	150	180	25
007330150240	150	240	25



**Decapagem de tintas, polimento de pedra, mármore e vidro**

Painted surface Ink removal, stone polishing, marmol and glass.

Décapage de peintures, polissage de pierre, marbre et verre.

Decapado de pinturas, pulido de piedra, mármore y vidrio.





# DISCOS ABRASIVOS

Abrasive Discs / Disques Abrasifs / Discos Abrasivos

## Rolos Abrasivos para Polimento e Pré-Polimento

Roller Abrasives for Coarse and Fine Finishing / Roues à Lamelles pour Polissage et Pré-Polissage / Rodillos Abrasivos para Pulido y Prepulido



### ROLO LIXA 100X100 / FLAP WHEEL 100X100 / ROUE À LAMELLES 100X100 / RODILLO LIXA 100X100

CÓDIGO CODE / CODE / CÓDIGO	DIÂMETROS DIAMETERS / DIAMÈTRES / DIAMETROS	GRÃO GRITS / GRAIN / GRANO	LARGURA WIDTH / LARGEUR / ANCHO	FURO BORE / TROU / AGUJERO	EMBALAGEM QUANTITY / EMBALLAGE / EMBALAJE
006602040000	100	40	100	19	1
006602060000	100	60	100	19	1
006602080000	100	80	100	19	1



#### Para remoção de ferrugem, oxidações, pequenos riscos, revestimentos, recuperação e polimento de metais

For removing rust, oxide layers, minor scratches, coatings and for regaining and burnishing metals

For removing rust, oxide layers, minor scratches, coatings and for regaining and burnishing metals

Para eliminación de herrumbre, oxidaciones, pequeñas rayas, revestimientos, recuperación y pulido de metales



### ROLO LIXA MISTO 100X100 E 100X150 / INTERLEAVE (COMBI) WHEEL 100X100 E 100X150 / ROUE À LAMELLES MIXTE 100X100 ET 100X150 / RODILLO LIXA MIXTO 100X100 Y 100X150

CÓDIGO CODE / CODE / CÓDIGO	DIÂMETROS DIAMETERS / DIAMÈTRES / DIAMETROS	GRÃO GRITS / GRAIN / GRANO	LARGURA WIDTH / LARGEUR / ANCHO	FURO BORE / TROU / AGUJERO	EMBALAGEM QUANTITY / EMBALLAGE / EMBALAJE
006603040000	100	40	100	19	1
006603060000	100	60	100	19	1
006603080000	100	80	100	19	1
006603150000	100	150	100	19	1
006603101508	100	80	150	19	1
006603101518	100	180	150	19	1



#### Para a obtenção de acabamento escovado e mate e remoção de pequenos riscos

For matt and satin finishes and removing minor scratches

Pour l'obtention d'une finition brossée et mate et retrait de petites rayures

Para la obtención de acabado escobado y mate y eliminación de pequeñas rayas



### ROLO ESFREGÃO 100X100 E 100X150 / FLEECE WHEEL-NONWOVEN 100X100 E 100X150 / ROUE À POLIR 110X100 ET 100X150 / RODILLO ESTROPAJO 100X100 Y 100X150

CÓDIGO CODE / CODE / CÓDIGO	DIÂMETROS DIAMETERS / DIAMÈTRES / DIAMETROS	GRÃO GRITS / GRAIN / GRANO	LARGURA WIDTH / LARGEUR / ANCHO	FURO BORE / TROU / AGUJERO	EMBALAGEM QUANTITY / EMBALLAGE / EMBALAJE
006604110101	110	60	100	19	1
006604110102	110	80	100	19	1
006604110103	110	180	100	19	1
006604110104	110	280	100	19	1
006604110151	100	60	150	19	1
006604110152	100	80	150	19	1
006604110153	100	180	150	19	1
006604110154	100	280	150	19	1



#### Para polimento e remoção de sombras nas superfícies (com acabamento sem brilho ou acetinado), pré-polimento, remoção de oxidações para alisamento de chapas metálicas

For the shadow-free completion of industrial grinding finishes (matt and satin), prepolishing, removing oxide layers and for smoothing preground sheets. For smoothing surfaces

Pour le polissage et retrait de ombres sur les surfaces (avec finition sans brillance ou satiné), pré-polissage, enlèvement d'oxydations et pour le lissage de feuilles métalliques

Para pulido y eliminación de sombreados en las superficies (con acabado sin brillo o satinado), prepulido, eliminación de oxidaciones y para alisado de chapas metálicas



### DISCOS ALGODÃO / TOP FINISH RING SOFT / ROUE EN COTON / DISCOS ALGODÓN

CÓDIGO CODE / CODE / CÓDIGO	DIÂMETROS DIAMETERS / DIAMÈTRES / DIAMETROS	LARGURA WIDTH / LARGEUR / ANCHO	EMBALAGEM QUANTITY / EMBALLAGE / EMBALAJE
006710012002	100	19	5



#### Combine Discos Algodão com

#### Pasta de polimento - AZUL

Combine Top Finish Ring Soft with Polish Compound - BLUE

Combiner la Roue en Coton avec Pâte de Polissage - BLEU

Combine Discos Algodón con Pasta de pulido - AZUL



#### Produto fabricado em algodão extra-suave | Para acabamento super polido e efeito espelhado

Product made of extra soft technical fleece | For the final polish - top mirror finish

Produit fabriqué en coton extra doux | Pour finition super polie et effet miroir

Producto fabricado en algodón extrasuave | Para acabado superpulido y efecto espejado



### ROLO DE SISAL / SISAL WHEEL / ROUE SISAL / RODILLO DE SISAL

CÓDIGO CODE / CODE / CÓDIGO	DIÂMETROS DIAMETERS / DIAMÈTRES / DIAMETROS	LARGURA WIDTH / LARGEUR / ANCHO	EMBALAGEM QUANTITY / EMBALLAGE / EMBALAJE
006606101001	100	100	1



#### Combine Rolo de Sisal com

#### Pasta de polimento - BRANCA

Combine Sisal wheel with Polish Compound - WHITE

Combiner la Roue Sisal avec Pâte de Polissage - BLANCHE

Combine Rodillo de Sisal con Pasta de pulido - BLANCA



#### Produto fabricado em corda de sisal | Para efetuar acabamento tipo polido e escovado

Product made of elastic fibre brush | For polishing stained wood surface, creating matt sheen effects and for pore-deep dust removal and cleaning

Produit fabriqué en corde de sisal | Pour effectuer une finition type polie et brossée

Producto fabricado en cuerda de sisal | Para efectuar acabado tipo pulido y escobado

## Consulte o nosso guia de ACABAMENTOS

Check our finishing table  
/ Consulter notre table de finition  
/ Consulte nuestra tabla de acabado



QR  
CODE

## Bandas e Cintas Abrasivas para Polidora de Rolos e Cintas

Polishing Sleeves for Expansion Roller and Polishing Belts / Bandes Abrasives pour Ponceuse à Bandes / Bandas y Cintas Abrasivas para Pulidora de Rodillos y Cintas

### ZIRCONIUM GRINDING SLEEVE AND BELT / BANDES ABRASIF DE ZIRCON / BANDAS Y CINTAS DE LIJA DE ZIRCONIO / BANDAS E CINTAS DE LIJA DE ZIRCÓNIO

CÓDIGO CODE / CODE / CÓDIGO	TIPO TYPE / TYPE / TIPO	GRÃO GRITS / GRAIN / GRANO	LARGURA WIDTH / LARGEUR / ANCHO	COMPRI- MIMENTO LENGTH / LONGUEUR / LARGO	EMBALAGEM QUANTITY / EMBALLAGE / EMBALAJE
007340294040	Banda / Roller / Bandes / Bandas	40			1
007340294060	Banda / Roller / Bandes / Bandas	60	100	289	1
007340294080	Banda / Roller / Bandes / Bandas	80			1
007340294120	Banda / Roller / Bandes / Bandas	120			1
007330760040	Cinta / Belt / Bandes / Bandas	40			10
007330760060	Cinta / Belt / Bandes / Bandas	60	40	760	10
007330760080	Cinta / Belt / Bandes / Bandas	80	40		10
007330760120	Cinta / Belt / Bandes / Bandas	120			10
007330760220	Cinta / Belt / Bandes / Bandas	220			10
007330780060	Cinta / Belt / Bandes / Bandas	60			10
007330780080	Cinta / Belt / Bandes / Bandas	80			10
007330780120	Cinta / Belt / Bandes / Bandas	120			10



#### Remoção de riscos profundos, ferrugem, camadas oxidadas, remoção e aperfeiçoamento de soldadura

Removal of deep scratches, rust and welds

Retrait de rayures profondes, rouille, couches oxydées, retrait et e perfectionnement de soudure

Eliminación de arañazos profundos, herrumbre, capas oxidadas, eliminación y perfeccionamiento de soldadura

### BANDAS E CINTAS DE LIJA DE ÓXIDO DE ALUMÍNIO

ALUMINIUM OXIDE SLEEVE AND BELT / BANDES ABRASIF D'OXYDE D'ALUMINIUM / BANDAS Y CINTAS DE LIJA DE ÓXIDO DE ALUMINIO

CÓDIGO CODE / CODE / CÓDIGO	TIPO TYPE / TYPE / TIPO	GRÃO GRITS / GRAIN / GRANO	LARGURA WIDTH / LARGEUR / ANCHO	COMPRI- MIMENTO LENGTH / LONGUEUR / LARGO	EMBALAGEM QUANTITY / EMBALLAGE / EMBALAJE
007341294040	Banda / Roller / Bandes / Bandas	40			1
007341294060	Banda / Roller / Bandes / Bandas	60	100	289	1
007341294080	Banda / Roller / Bandes / Bandas	80			1
007341294120	Banda / Roller / Bandes / Bandas	120			1
007341294180	Banda / Roller / Bandes / Bandas	180			1
007331760040	Cinta / Belt / Bandes / Bandas	40			10
007331760060	Cinta / Belt / Bandes / Bandas	60	40	760	10
007331760080	Cinta / Belt / Bandes / Bandas	80	40		10
007331760120	Cinta / Belt / Bandes / Bandas	120			10
007331760220	Cinta / Belt / Bandes / Bandas	220			10



#### Remoção de riscos profundos, ferrugem, camadas oxidadas, remoção e aperfeiçoamento de soldadura

Removal of deep scratches, rust and welds

Retrait de rayures profondes, rouille, couches oxydées, retrait et e perfectionnement de soudure

Eliminación de arañazos profundos, herrumbre, capas oxidadas, eliminación y perfeccionamiento de soldadura

### TRIZAC™ SLEEVE AND BELT / BANDES ABRASIF TRIZAC™ / BANDAS Y CINTAS DE LIJA TRIZAC™ / BANDAS E CINTAS DE LIJA TRIZAC™

CÓDIGO CODE / CODE / CÓDIGO	TIPO TYPE / TYPE / TIPO	GRÃO GRITS / GRAIN / GRANO	LARGURA WIDTH / LARGEUR / ANCHO	COMPRI- MIMENTO LENGTH / LONGUEUR / LARGO	EMBALAGEM QUANTITY / EMBALLAGE / EMBALAJE
007343294001	Banda / Roller / Bandes / Bandas	A-100 (220)			5
007343294002	Banda / Roller / Bandes / Bandas	A-65 (320)			5
007343294003	Banda / Roller / Bandes / Bandas	A-45 (400)	100	289	5
007343294004	Banda / Roller / Bandes / Bandas	A-30 (600)			5
007343294005	Cinta / Belt / Bandes / Bandas	A-16 (1200)			5
007343294006	Cinta / Belt / Bandes / Bandas	A-06 (2000)			5
007333760100	Cinta / Belt / Bandes / Bandas	A-100 (220)			5
007333760320	Cinta / Belt / Bandes / Bandas	A-65 (320)			5
007333760400	Cinta / Belt / Bandes / Bandas	A-45 (400)	40	760	5
007333760600	Cinta / Belt / Bandes / Bandas	A-30 (600)			5
007333761200	Cinta / Belt / Bandes / Bandas	A-16 (1200)			5
007333762000	Cinta / Belt / Bandes / Bandas	A-06 (2000)			5



#### Remoção de riscos profundos e preparação de peças para acabamentos polido ou espelhado

Ideal for removing scratches and for pregrinding to polishing or to a mirror finish

Retrait de rayures profondes et préparation de pièces pour finition polie ou effet miroir

Eliminación de arañazos profundos y preparación de piezas para acabados pulido o espejado





# DISCOS ABRASIVOS

Abrasive Discs / Disques Abrasifs / Discos Abrasivos

## Bandas e Cintas Abrasivas para Polidora de Rolos e Cintas

Polishing Sleeves for Expansion Roller and Polishing Belts / Bandes Abrasives pour Ponceuse à Bandes / Bandas y Cintas Abrasivas para Pulidora de Rodillos y Cintas

### BANDA E CINTA DE ESFREGÃO | NYLON FLEECE SLEEVE AND BELT / BANDE DE TISSU ABRASIF / BANDA Y CINTA DE ESTROPAJO

CÓDIGO CODE / CODE / CÓDIGO	TIPO TYPE / TYPE / TIPO	GRÃO GRITS / GRAIN / GRANO	LARGURA WIDTH / LARGEUR / ANCHO	COMPRIMENTO LENGTH / LONGUEUR / LARGO	EMBALAGEM QUANTITY / EMBALLAGE / EMBALAJE
007342294060	Banda / Roller / Bandes / Bandas	80	100	289	1
007342294080	Banda / Roller / Bandes / Bandas	120			1
007342294180	Banda / Roller / Bandes / Bandas	180			1
007342294280	Banda / Roller / Bandes / Bandas	240			1
007334760080	Cinta / Belt / Bandes / Bandas	60	40	760	5
007334760120	Cinta / Belt / Bandes / Bandas	80			5
007334760240	Cinta / Belt / Bandes / Bandas	180			5
007334780080	Cinta / Belt / Bandes / Bandas	60			5
007334780120	Cinta / Belt / Bandes / Bandas	80			5
007334780240	Cinta / Belt / Bandes / Bandas	180			5



#### Remoção de pequenos riscos e camadas oxidadas | Criação de efeito matizado e satinado em superfícies

For removing minor scratches and oxide layers, matt and satin finishes and deburring pipe construction and handrails

Retrait de petites rayures et couches oxydées | Création d'effet dépoli et satiné en surfaces

Eliminación de pequeños arañazos y capas oxidadas | Creación de efecto mate y satinado en superficies



## Esfregão Abrasivo

Nylon Abrasive Fleece / Tissu Abrasif de Nylon / Estropajo Abrasivo

### FOLHAS DE MALHA ABRASIVA / BAND PADS / FEUILLES D'ABRASIF / HOJAS DE MALLA ABRASIVA

CÓDIGO CODE / CODE / CÓDIGO	DIMENSÕES SIZE / DIMENSIONS / MEDIDA	GRÃO GRITS / GRAIN / GRANO	EMBALAGEM QUANTITY / EMBALLAGE / EMBALAJE
007310082812	280 x 120 x 8	120	20
007311082812	280 x 120 x 8	180	20
007312082812	280 x 120 x 8	240	20

### ROLOS / ROLLS / ROULEAUX / ROLLOS

CÓDIGO CODE / CODE / CÓDIGO	DIMENSÕES SIZE / DIMENSIONS / MEDIDA	GRÃO GRITS / GRAIN / GRANO	EMBALAGEM QUANTITY / EMBALLAGE / EMBALAJE
007313600001	100 mm x 5 mts	80	1
007313600002	100 mm x 5 mts	120	1
007313600003	100 mm x 5 mts	180	1
007313600004	100 mm x 5 mts	240	1



#### Ideais para retirar pequenos riscos ou camadas de oxidação | Ideais para criar acabamentos do tipo "mate", "satinado" e "espejado", consoante o grão abrasivo utilizado

For removing minor scratches and oxide layers, matt and satin finishes, deburring and final grinding

Idéals pour retirer des petites rayures ou couches d'oxydation | Idéals pour créer des finitions de type "mate", "satiné" et "réfléchissante", selon le grain abrasif utilisé

Ideales para eliminar pequeñas rayas o capas de oxidación | Ideales para crear acabados del tipo "mate", "satinado" y "espejado", según el grano abrasivo utilizado

#### Folhas de malha abrasiva (280 x 120 mm)

/ band pads (280 x 120 mm)  
/ Feuilles d'abrasif (280 x 120 mm)  
/ Hojas de malha abrasiva (280 x 120 mm)



#### Rolos (5 mts)

/ Rolls (5 mts)  
/ Rouleaux (5 mts)  
/ Rollos (5 mts)





## Rebolo Abrasivo Misto C/ Espigão

Mounted Non-Woven Wheels Mix Abrasive Mop / Roue à Lamelles Mixte avec Axe / Abanico Mixto de Lija y Malla Abrasiva c/ Vástago

CÓDIGO CODE / CODE / CÓDIGO	GRÃO GRITS / GRAIN / GRANO	S <sub>d</sub> x L	D	T	EMBALAGEM QUANTITY / EMBALLAGE / EMBALAJE
006601060000	60	6 x 40	60	30	1
006601100000	100	6 x 40	60	30	1
006601150000	150	6 x 40	60	30	1

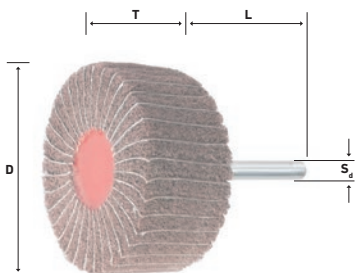

**Legenda**

D - Diâmetro do Rebolo / Abrasive Mop Diameter / Diamètre de la Roue / Diámetro del Abanico  
T - Espessura do Rebolo / Abrasive Mop Thickness / Épaisseur de la Roue / Espesor del Abanico  
L - Comprimento da haste / Shank length / Longueur de la tige / Largo del vástago  
S<sub>d</sub> - Diâmetro da haste / Shank diameter / Diamètre de la tige / Diámetro del vástago



**Para remoção de pequenos riscos, óxidos e películas | Acabamento esmerilado brilhante**

For removing minor scratches, oxide and coatings | Brush matting on stainless steel

Pour le retrait de petites rayures, oxydes et pellicules | Finition dépoli brillante

Para eliminación de pequeños arañazos, óxidos y películas | Acabado esmerilado brillante

## Rebolo Abrasivo c/ Espigão

Mounted Flap Wheels Abrasive Mop / Roue à Lamelles avec Axe / Abanico de Lija c/ Vástago

ALUMINIUM OXIDE / ÓXIDO DE ALUMÍNIO / ÓXIDO DE ALUMÍNIO / ÓXIDO DE ALUMÍNIO

CÓDIGO CODE / CODE / CÓDIGO	GRÃO GRITS / GRAIN / GRANO	S <sub>d</sub> x L	D	T	RPM	MAX RPM	EMBALAGEM QUANTITY / EMBALLAGE / EMBALAJE	QTD. PALETTE PALET / QT. PALETTE / CANT. PALÉ
006605040400	40	6 x 40	40	20	7.940	19.100	10	800
006605040600	60	6 x 40	40	20	7.940	19.100	10	800
006605040800	80	6 x 40	40	20	7.940	19.100	10	800
006605041200	120	6 x 40	40	20	7.940	19.100	10	800
006604040000	40	6 x 35	60	30	7.940	12.700	10	1800
006604060000	60	6 x 35	60	30	7.940	12.700	10	1800
006604080000	80	6 x 35	60	30	7.940	12.700	10	1800
006604120000	120	6 x 35	60	30	7.940	12.700	10	1800
006605080400	40	6 x 40	80	40	7.940	9.600	10	3200
006605080600	60	6 x 40	80	40	7.940	9.600	10	3200
006605080800	80	6 x 40	80	40	7.940	9.600	10	3200
006605081200	120	6 x 40	80	40	7.940	9.600	10	3200



Óxido de alumínio  
/ Aluminium Oxide  
/ Óxido de alumínio  
/ Óxido de aluminio

ZIRCONIA / ZIRCÔNIO / ZIRCONIO / ZIRCÓNIO

CÓDIGO CODE / CODE / CÓDIGO	GRÃO GRITS / GRAIN / GRANO	S <sub>d</sub> x L	D	T	MAX RPM	VELOCIDADE RECOMENDADA / RECOMMENDED SPEED (M/S) / VITESSE RECOMMANDÉE (M/S) / VELOCIDAD RECOMENDADA (M/S)	EMBALAGEM QUANTITY / EMBALLAGE / EMBALAJE
006600040000	40	6 x 40	60	20	12.750	60	1
006600060000	60	6 x 40	60	20	12.750	60	1
006600080000	80	6 x 40	60	20	12.750	60	1
006601200000	120	6 x 40	60	20	12.750	60	1

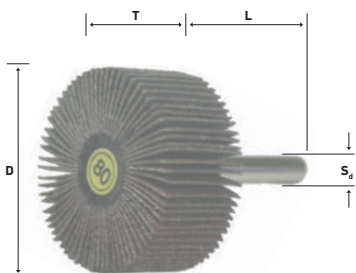

**Legenda**

D - Diâmetro do Rebolo / Abrasive Mop Diameter / Diamètre de la Roue / Diámetro del Abanico  
T - Espessura do Rebolo / Abrasive Mop Thickness / Épaisseur de la Roue / Espesor del Abanico  
L - Comprimento da haste / Shank length / Longueur de la tige / Largo del vástago  
S<sub>d</sub> - Diâmetro da haste / Shank diameter / Diamètre de la tige / Diámetro del vástago



Zircônio  
/ Zirconia  
/ Zircônio  
/ Zirconio



**Para remoção de pequenos riscos, óxidos e películas | Acabamento esmerilado brilhante**

For removing minor scratches, oxide and coatings | Brush matting on stainless steel

Pour le retrait de petites rayures, oxydes et pellicules | Finition dépoli brillante

Para eliminación de pequeños arañazos, óxidos y películas | Acabado esmerilado brillante



# DISCOS ABRASIVOS

Abrasive Discs / Disques Abrasifs / Discos Abrasivos

## Disco Nylon

Nylon Clean Discs / Disque Nylon / Disco Nylon



### DISCO NYLON COM PRATO / Nylon Clean Disc with plate / Disque Nylon a/ plateau / Disco Nylon c/ plato

CÓDIGO CODE / CODE / CÓDIGO	DIMENSÕES SIZE / DIMENSIONS / MEDIDA	MÁX RPM MAX RPM / MAX RPM / MÁX RPM	EMBALAGEM QUANTITY / EMBALLAGE / EMBALAJE
006700221150	115 x 15 x 22	5000	10

### DISCO NYLON SEM PRATO / Nylon Clean Disc without plate / Disque Nylon s/ plateau / Disco Nylon s/ plato

CÓDIGO CODE / CODE / CÓDIGO	DIMENSÕES SIZE / DIMENSIONS / MEDIDA	MÁX RPM MAX RPM / MAX RPM / MÁX RPM	EMBALAGEM QUANTITY / EMBALLAGE / EMBALAJE
006700111000	100 x 16 x 11	6000	5
006700115000	150 x 16 x 11	4000	5

## Acessórios / Accessory / Accessoire / Accesorio

### ADAPTADOR PARA DISCO NYLON S/ PRATO

Adapter Nylon Clean Disc / Adaptateur pour Disque Nylon s/ plateau / Adaptador para Disco Nylon s/ plato

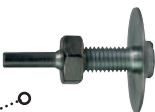
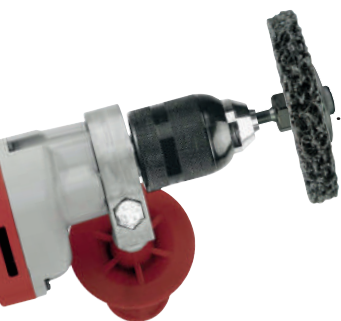

CÓDIGO CODE / CODE / CÓDIGO	DIMENSÕES SIZE / DIMENSIONS / MEDIDA	EMBALAGEM QUANTITY / EMBALLAGE / EMBALAJE
006700060100	10 x 6	1



**Ideal para limpeza e remoção de revestimentos, corrosão e sujidade em todo o tipo de materiais.**

*Ideal for cleaning and pore-deep removal of coatings, rust, scale and dirt on all materials.*

*Idéal pour le nettoyage et le retrait de revêtements, corrosion et saleté sur tous types de matériaux.*

*Ideal para limpieza y eliminación de revestimientos, corrosión y suciedad en todo tipo de materiales.*

## Cinta de Lixa para Madeira - Óxido de Alumínio

Abrasive Aluminium Oxide belt / Bande Abrasive pour Bois / Cinta de Lixa para Madera

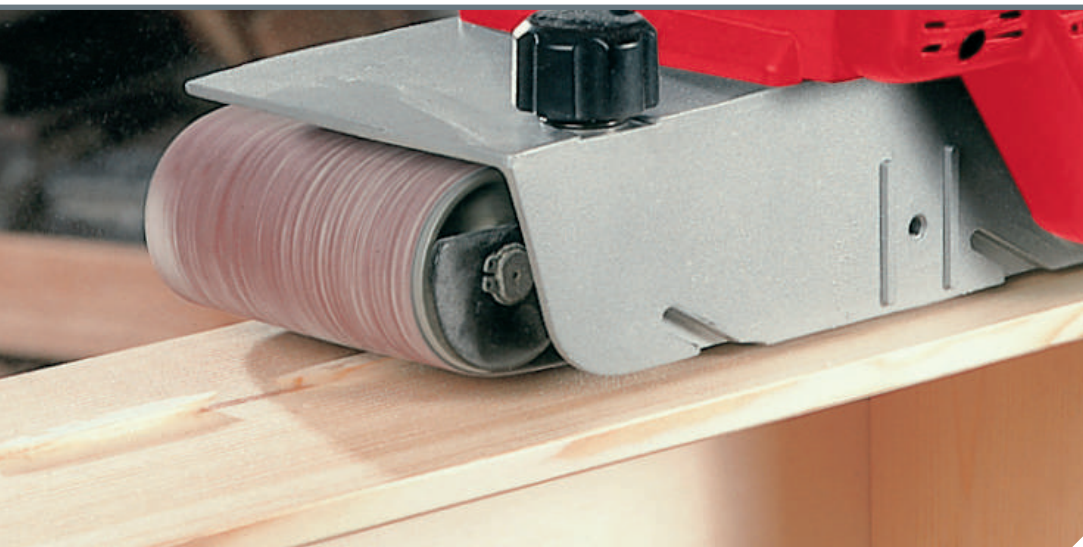

CÓDIGO CODE / CODE / CÓDIGO	GRÃO GRITS / GRAIN / GRANO	DIMENSÕES SIZE / DIMENSIONS / MEDIDA	EMBALAGEM QUANTITY / EMBALLAGE / EMBALAJE
007335620060	60	100 x 620	10
007335620080	80	100 x 620	10
007335620100	100	100 x 620	10



**Produto ideal para a remoção de superfícies irregulares para todos os tipos de madeiras, placas de aglomerado e de construção**

*Ideal product to irregular wood surface removal, construction and wood shavings*

*Produit idéal pour le retrait de surfaces irrégulières pour tous types de bois, plaques d'aggloméré et de construction*

*Producto ideal para la eliminación de superficies irregulares para todos los tipos de maderas, placas de aglomerado y de construcción*



# DISCOS DIAMANTADOS

DIAMOND WHEEL  
DISQUES DIAMANT  
DISCOS DIAMANTADOS



# DISCOS DIAMANTADOS

Diamond Wheels / Disques Diamant / Discos Diamantados

## Discos Diamantados

Diamond Wheels / Disques Diamant / Discos Diamantados

### Guia de Aplicação

Application Guide / Guide d'Application / Guía de Aplicación

Seco / Dry / Sec / Seco										
<b>Arenito</b> / Sandstone / Arénite / Arenisca										
<b>Bloco Pavimento ou Pavê</b> / Self-locking block / Pavé / Bloque de Pavimento o Pave										
<b>Betão</b> / Concrete / Béton / Hormigón										
<b>Betão Armado</b> / Reinforced concrete / Béton armé / Hormigón armado										
<b>Betão Fresco</b> / Green concrete / Béton frais / Hormigón fresco										
<b>Cerâmica</b> / Ceramic / Céramique / Cerámica										
<b>Tijolo Cerâmico</b> / Fired bricks / Brique céramique / Ladrillo de Barro										
<b>Betão Agregado</b> / Aggregated concrete / Béton aggloméré / Hormigón Agregado										
<b>Granito</b> / Granite / Granite / Granito										
<b>Porcelanato</b> / Porcelain tile / Grès Cérame / Porcelanato										
<b>Viroc</b> / Wood-concrete bricks / Viroc / Viroc										
<b>"Argamassa" de Cimento ou Clinker</b> / Clinker / "Mortier" de Ciment ou Clinker / Argamasa de Cemnto o Clinker										
<b>Mármore</b> / Marble / Marble / Mármol										
<b>Tijolo Maciço</b> / Bricks / Brique réfractaire / Ladrillo Macizo										
<b>Pórfiro</b> / Porphyry / Porphyre / Pórfido										
<b>Tijolo Perfurado</b> / Poroton / Brique creuse / Ladrillo perforado										
<b>PVC</b> / PVC / PVC / PVC										
<b>Cimento Refratário</b> / Refractory / Ciment réfractaire / Cemento refractario										
<b>Travertino</b> / Tuff / Travertín / Travertino										

Molhado / Wet / Moillé / Mojado				
<b>Asfalto</b> / Asphalt / Asphalte / Asfalto				
<b>Betão Fresco</b> / Green concrete / Béton frais / Hormigón fresco				
<b>Betão Curado</b> / Cured concrete / Béton / Hormigón				

**IDEAL**  
/ Ideal / Idéal / Ideal

**ADEQUADO**  
/ Suitable / Adéquat / Apropiado

**NÃO ADEQUADO**  
/ Not suitable / Non adéquat / No aconsejado

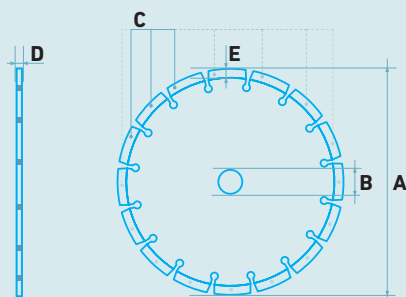

**A** DIÂMETRO  
/ Diameter / Diamètre / diámetro

**B** FURO Ø  
/ Ø Hole / Ø Trou / Ø Agujero

**C** Nº DE SEGMENTOS  
/ N° segments / N° de Segments / N° de Segmentos

**D** ESPESSURA DO SEGMENTO  
/ Segment thickness / Segment épaisseur / Espesor segmento

**E** ALTURA DO SEGMENTO  
/ Segment height / Hauteur du segment / Altura del segmento

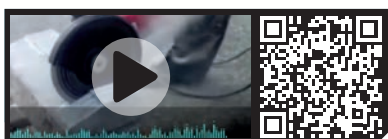

## Disco Diamantado Segmentado Laser Silencioso

Diamond Wheel Segmented Laser Silent / Disques Diamant Ligne Segments Laser Silencieux / Disco Diamantado Segmentado Láser Silencioso

CÓDIGO CODE / CODE / CÓDIGO	DIMENSÕES SIZE / DIMENSIONS / MEDIDA					EMBALAGEM QUANTITY / EMBALLAGE / EMBALAJE
	A	B	C	D	E	
008310111150	115	22.2	9	2.3	12	1
008310112300	230	22.2	16	3.0	12	1



**Corte rápido e agressivo | Segmento especial aumenta a duração do disco em 40% (c.a.) | Reduz o consumo de energia | Maior conforto para ao operador (silencioso) | Performance constante do disco durante a sua duração**

*Better and faster cutting | The special segment increases the duration of the disc of approx. 40% | Reduces power consumption | More confort to the operator (silent) | Constant disc performance over lifetime*

*Coupe rapide et agressive | Segment spécial prolongeant la durée du disque en 40%(c.a.) | Réduit la consommation d'énergie | Plus de confort pour l'opérateur (silencieux) | Performance constante du disque pendant la validité*

*Corte rápido y agresivo | Segmento especial aumenta la duración del disco en 40% (c.a.) | Reduce el consumo de energía | Mayor confort para el operario (silencioso) | Prestación constante del disco durante su vida útil*



## Disco Diamantado Laser Intercooler

Diamond Wheel Laser Intercooler / Disques Diamant Laser Intercooler / Disco Diamantado Láser Intercooler

CÓDIGO CODE / CODE / CÓDIGO	DIMENSÕES SIZE / DIMENSIONS / MEDIDA					EMBALAGEM QUANTITY / EMBALLAGE / EMBALAJE
	A	B	C	D	E	
008301201150	115	22.2	9	2.3	10	1
008301202300	230	22.2	16	2.7	10	1



**Os furos entre os segmentos permitem um arrefecimento do disco, reduzindo a temperatura durante o corte, bem como uma maior rapidez de corte.**

*The slots between the diamond segments provide a faster cut as well as an improved disc cooling and reduce heating when cutting.*

*Les trous entre les segments permettent un rafraichissement du disque, réduisant la température pendant la coupe et une plus grande vitesse.*

*Los agujeros entre los segmentos permiten un enfriamiento del disco, reduciendo la temperatura durante el corte, así como una mayor rapidez del mismo.*



## Disco Diamantado Segmentado Geral Obra Laser

Diamond Wheel Segmented Laser Multipurpose / Disques Diamant Ligne Segments Universal Laser / Disco Diamantado Segmentado General Obra Láser

CÓDIGO CODE / CODE / CÓDIGO	DIMENSÕES SIZE / DIMENSIONS / MEDIDA					EMBALAGEM QUANTITY / EMBALLAGE / EMBALAJE
	A	B	C	D	E	
008301071150	115	22.2	9	2.2	10	1
008301071250	125	22.2	10	2.2	10	1
008301071800	180	22.2	14	2.6	10	1
008301072300	230	22.2	16	2.6	10	1



**Disco diamantado muito versátil permite um corte rápido numa vasta gama de materiais presentes na construção civil | Os segmentos soldados a laser proporcionam total segurança durante a utilização**

*Very versatile blade enabling fast cutting of a wide range of materials present in building construction | In addition provides total safety by the laser welding*

*Les disques diamant permettent une coupe rapide, sur divers matériaux de construction | Les segments soudés au laser proportionnent une totale sécurité pendant l'utilisation*

*Disco diamantado muy versátil permite un corte rápido en una amplia gama de materiales presentes en la construcción civil | Los segmentos soldados con láser proporcionan total seguridad durante la utilización*





# DISCOS DIAMANTADOS

Diamond Wheels / Disques Diamant / Discos Diamantados

## Disco Diamantado Turbo

Diamond Wheel Turbo / Disque Diamant Turbo / Disco Diamantado Turbo



CÓDIGO CODE / CODE / CÓDIGO	DIMENSÕES SIZE / DIMENSIONS / MEDIDA					EMBALAGEM QUANTITY / EMBALLAGE / EMBALAJE
	A	B	C	D	E	
008300071150	115	22.2	-	2.2	8	1
008300072300	230	22.2	-	2.6	9	1



**A banda contínua com segmentos inclinados proporciona um acabamento perfeito e uma boa performance de corte**

*The continuous rim design has an extremely narrow pitch, allowing perfect finishing with very good cutting edges*

*La bande continue avec segments inclinés proportionne une finition parfaite et une bonne performance de coupe*

*La banda continua con segmentos inclinados proporciona un acabado perfecto y una buena prestación de corte*

## Disco Diamantado Turbo Extra Fino

Diamond Wheel Turbo Extra Thin / Disque Diamant Turbo Extra Fin / Disco Diamantado Turbo Extra Fino



CÓDIGO CODE / CODE / CÓDIGO	DIMENSÕES SIZE / DIMENSIONS / MEDIDA					EMBALAGEM QUANTITY / EMBALLAGE / EMBALAJE
	A	B	C	D	E	
008302071150	115	22.2	-	1	7	1
008302071250	125	22.2	-	1.5	10	1
008302072300	230	22.2	-	2	10	1



**Corte perfeito e elevada duração no corte de cerâmicas duras**

*Perfect cutting and long life line for cutting high hardness ceramic*

*Coupe parfaite et grande durabilité dans la coupe de céramiques dures*

*Corte perfecto y elevada duración en el corte de cerâmicas duras*

## Disco Diamantado Turbo Plus 150 (Abrir Roços)

Diamond Wheel Plus 150 Turbo (Wall chaser) / Disque Diamant Turbo Plus 150 (ouvrir rainures) / Disco Diamantado Turbo Plus 150 (abrir rozas)



CÓDIGO CODE / CODE / CÓDIGO	DIMENSÕES SIZE / DIMENSIONS / MEDIDA					EMBALAGEM QUANTITY / EMBALLAGE / EMBALAJE
	A	B	C	D	E	
008303071500	150	22.2	-	2.3	9	1



**O reforço de diamante na alma do disco proporciona um corte rápido mesmo nos materiais mais duros.**

*The side diamond inserts provide a fast cutting even on hardest materials.*

*Le renfort latéral de diamant dans le disque offre une coupe rapide même sur les matériaux les plus durs.*

*El reforzo de diamante en la alma del disco proporciona un corte rápido incluso en los materiales más duros.*



## Disco Diamantado SC Cerâmica

Diamond Wheel SC Ceramics / Disque Diamant SC Céramique / Disco Diamantado SC Cerâmica

CÓDIGO CODE / CODE / CÓDIGO	DIMENSÕES SIZE / DIMENSIONS / MEDIDA					EMBALAGEM QUANTITY / EMBALLAGE / EMBALAJE
	A	B	C	D	E	
008305051150	115	22.2	-	2.2	8	1
008305052300	230	22.2	-	2.4	10	1



**Confere um acabamento perfeito e reduz o esmiilhar dos materiais cortados**

*Reduces splintering at cut edges and gives a perfect finishing at surface*

*Confère une finition parfaite et réduit l'émission des matériaux coupés*

*Confiere un acabado perfecto y reduce el desmenuzado de los materiales cortados*



## Disco Diamantado Extra Fino Plus (Porcelanato)

Diamond blade Extra Fine Plus (Porcelain Tiles) / Lame de diamant Extra Fine Plus (Porcelaine) / Disco de diamante Extra Fine Plus (Porcelanato)

CÓDIGO CODE / CODE / CÓDIGO	DIMENSÕES SIZE / DIMENSIONS / MEDIDA					EMBALAGEM QUANTITY / EMBALLAGE / EMBALAJE
	A	B	C	D	E	
008302081150	115	22.2	-	1.2	7	1
008302081230	230	22.2	-	1.2	9	1



**O melhor disco para grés, porcelanato, cerâmica e materiais vidrados**

*The highest performance on gres, porcelanate, vitrified materials and ceramic cutting*

*Le meilleur disque pour grès, porcelaine, céramique et matériaux vitrifiés*

*El mejor disco para gres, porcelanato, cerámica y materiales vidriados*



## Disco Diamantado Eletrodepositado Mármore

Diamond Wheel Electroplated Marble / Disques Diamant Électrodéposé pour Marbre / Disco Diamantado Electrodepositado Mármore

CÓDIGO CODE / CODE / CÓDIGO	DIMENSÕES SIZE / DIMENSIONS / MEDIDA					EMBALAGEM QUANTITY / EMBALLAGE / EMBALAJE
	A	B	C	D	E	
008312081150	115	22.2	14	2.7	3	1
008312082300	230	22.2	22	2.7	3	1



**Corte perfeito, suave e sem poeira na mármore.**

*Perfect, soft, clean and precise cut on marble.*

*Coupe parfaite, douce et sans poussières dans le marbre.*

*Corte perfecto, suave y sin polvo en mármol.*



## Disco Diamantado Granito

Diamond Wheel Laser Granite / Disques Diamant Granite / Disco Diamantado Granito

CÓDIGO CODE / CODE / CÓDIGO	DIMENSÕES SIZE / DIMENSIONS / MEDIDA					EMBALAGEM QUANTITY / EMBALLAGE / EMBALAJE
	A	B	C	D	E	
008304121150	115	22.2	8	2.3	10	1
008304122300	230	22.2	16	2.6	10	1



**Ideal para corte de granito de diversas durezas e outros materiais duros**

*Suitable for granite cutting of any kind and other hard materials.*

*Idéal pour couper du granite de diverses duretés et autres matériaux durs.*

*Idéal para corte de granito de diversas durezas y otros materiales duros*





# DISCOS DIAMANTADOS

Diamond Wheels / Disques Diamant / Discos Diamantados

## Discos Diamantados PECOL MASTERCUT

Pecol Mastercut Diamond Wheels / Disques Diamant Pecol Mastercut / Discos Diamantados Pecol Mastercut

### Guia de Aplicação

Application Guide / Guide d'Application / Guía de Aplicación

Seco Dry / Sec / Seco						
<b>Betão</b> Concrete / Béton / Hormigón						
<b>Betão Armado</b> Reinforced concrete / Béton armé / Hormigón armado						
<b>Pedra</b> Stone / Pierre / Piedra						
<b>Tijolo Perfurado</b> Poroton / Brique creuse / Ladrillo perforado						
<b>Tijolo Maciço</b> Bricks / Brique réfractaire / Ladrillo Macizo						
<b>Telha</b> Tile / Tuile / Teja						
<b>Granito</b> Granite / Granite / Granito						
<b>Grés</b> Sandstone / Grés / Grés						
<b>Porcelanato</b> Porcelain tile / Grés Cérame / Porcelanato						
<b>Cerâmica</b> Ceramic / Céramique / Cerámica						
<b>Mármore</b> Marble / Marbre / Mármol						



**IDEAL**

/ Ideal / Idéal / Ideal



**ADEQUADO**

/ Suitable / Adéquat / Apropriado



**NÃO ADEQUADO**

/ Not suitable / Non adéquat / No aconsejado

### QUALIDADE DE ACABAMENTO

Finishing Quality / Qualité de finition / Calidad de acabado



### RAPIDEZ DE CORTE

Cutting speed / Vitesse de Coupe / Rapidez de Corte

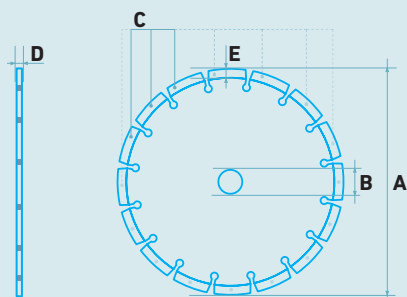
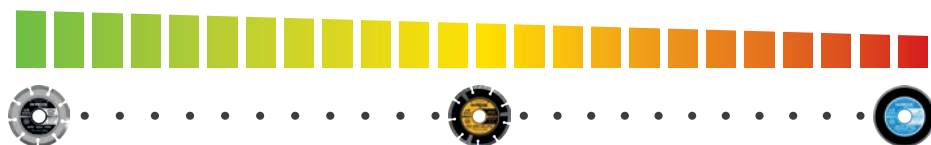

**A** DIÂMETRO  
/ Diameter / Diamètre / diámetro

**B** FURO Ø  
/ Ø Hole / Ø Trou / Ø Agujero

**C** Nº DE SEGMENTOS  
/ N° segments / N° de Segments / N° de Segmentos

**D** ESPESSURA DO SEGMENTO  
/ Segment thickness / Segment épaisseur / Espesor segmento

**E** ALTURA DO SEGMENTO  
/ Segment height / Hauteur du segment / Altura del segmento



## Disco Diamantado Geral Obra - PECOL MASTERCUT

General Work Diamond Disc - PECOL MASTERCUT / Disque Diamanté Travaux Généraux- PECOL MASTERCUT / Disco Diamantado General Obra - PECOL MASTERCUT

CÓDIGO CODE / CODE / CÓDIGO	DIMENSÕES SIZE / DIMENSIONS / MEDIDA					EMBALAGEM QUANTITY / EMBALLAGE / EMBALAJE
	A	B	C	D	E	
008301071151	115	22.2	9	2.2	7	1
008301072301	230	22.2	16	2.5	7	1



**Para um corte rápido e agressivo de betão, tijolo e pedra**  
For a fast and aggressive cutting of concrete, brick and stone  
Pour une coupe rapide et agressive du béton, de la brique et de la pierre  
Para un corte rápido y agresivo de hormigón, ladrillo y piedra

## Disco Diamantado Turbo Reforçado - PECOL MASTERCUT

Enhanced Turbo Diamond Disc - PECOL MASTERCUT / Disque Diamanté Turbo Renforcé - PECOL MASTERCUT / Disco Diamantado Turbo Reforzado - PECOL MASTERCUT

CÓDIGO CODE / CODE / CÓDIGO	DIMENSÕES SIZE / DIMENSIONS / MEDIDA					EMBALAGEM QUANTITY / EMBALLAGE / EMBALAJE
	A	B	C	D	E	
008303071151	115	22.2	9	2.2	7	1
008303072301	230	22.2	18	2.6	7	1



**Para um corte mais preciso e agressivo quando comparado com um disco Geral Obra**  
For a more precise and aggressive cut when compared to a General Work Disc  
Pour une coupe plus précise et agressive par rapport à un disque Travaux Généraux  
Para un corte más preciso y agresivo cuando en comparación con un disco General Obra

## Disco Diamantado Turbo - PECOL MASTERCUT

Turbo Diamond Disc - PECOL MASTERCUT / Disque Diamanté Turbo - PECOL MASTERCUT / Disco Diamantado Turbo - PECOL MASTERCUT

CÓDIGO CODE / CODE / CÓDIGO	DIMENSÕES SIZE / DIMENSIONS / MEDIDA					EMBALAGEM QUANTITY / EMBALLAGE / EMBALAJE
	A	B	C	D	E	
008300071151	115	22.2	-	2.2	7	1
008300072301	230	22.2	-	2.6	10	1



**Para um corte suave e com excelente acabamento em betão, pedra, mármore, tijolo, telha, granito e outros**  
For a smooth cut with excellent finish in concrete, stone, marble, brick, tile, granite and others  
Pour une coupe douce avec une excellente finition en béton, pierre, marbre, brique, tuile, granit et d'autres  
Para un corte suave y con excelente acabado en hormigón, piedra, mármol, ladrillo, teja, granito y otros

## Disco Diamantado Turbo Cerâmica - PECOL MASTERCUT

Turbo Ceramics Diamond Disc - PECOL MASTERCUT / Disque Diamanté Turbo Céramique - PECOL MASTERCUT / Disco Diamantado Turbo Cerámica - PECOL MASTERCUT

CÓDIGO CODE / CODE / CÓDIGO	DIMENSÕES SIZE / DIMENSIONS / MEDIDA					EMBALAGEM QUANTITY / EMBALLAGE / EMBALAJE
	A	B	C	D	E	
008302071151	115	22.2	-	1.4	7	1
008302071251	230	22.2	-	1.6	10	1



**Disco extremamente fino (1,4mm) para corte suave e sem esmilhar | Perfeito para corte de azulejo, mosaico, porcelanato e grés**  
Extremely thin (1.4 mm) disc for smooth and non-grinding cut | Perfect for cutting tile, mosaic, porcelain and sandstone  
Disque extrêmement mince (1,4mm) pour une coupe douce et sans briser | Parfait pour couper les carreaux, la mosaïque, la porcelaine et le grés  
Disco extremadamente fino (1,4 mm) para corte suave y sin laminar | Perfecto para corte de azulejo, mosaico, porcelanato y gres

## Disco Diamantado Sc Cerâmica - PECOL MASTERCUT

Sc Ceramic Diamond Disc - PECOL MASTERCUT / Disque Diamanté Sc Céramique - PECOL MASTERCUT / Disco Diamantado Sc Cerámica - PECOL MASTERCUT

CÓDIGO CODE / CODE / CÓDIGO	DIMENSÕES SIZE / DIMENSIONS / MEDIDA					EMBALAGEM QUANTITY / EMBALLAGE / EMBALAJE
	A	B	C	D	E	
008305051151	115	22.2	-	1.9	7	1
008305052301	230	22.2	-	2.4	7	1



**Ideal para corte de cerâmicas duras como grés e porcelanato | Bom desempenho no corte de azulejo, tijoleira, mosaico e cerâmicas de baixa dureza**  
Ideal for cutting hard ceramics such as sandstone and porcelain | Good performance in the cutting of tile, brick tile, mosaic and ceramics of low hardness  
Idéal pour couper des céramiques dures telles que le grés et le grés cérame | Bonne performance dans la coupe de carrelage, mosaïques et céramiques de faible dureté  
Ideal para corte de cerâmicas duras como gres y porcelanato | Buen rendimiento en el corte de azulejos, baldosas, mosaicos y cerámicas de baja dureza



# DISCOS DIAMANTADOS

Diamond Wheels / Disques Diamant / Discos Diamantados

## DISCO DIAMANTADO ASFALTO

Disco de alto rendimento e qualidade profissional específico para corte de asfalto.

/ DIAMOND WHEEL ASPHALT  
/ DISQUE DIAMANT POUR ASPHALTE  
/ DISCO DIAMANTADO PARA ASFALTO

## DISCO DIAMANTADO BETÃO CURADO

Disco de alto rendimento e qualidade profissional para corte de betão curado com e sem reforço, assim como materiais abrasivos.

/ DIAMOND WHEEL CURED CONCRETE  
/ DISQUE DIAMANT POUR BÉTON  
/ DISCO DIAMANTADO PARA HORMIGÓN CURADO

## DISCO DIAMANTADO BETÃO FRESCO

Disco de alto rendimento e qualidade profissional para corte de betão fresco.

/ DIAMOND WHEEL GREEN CONCRETE  
/ DISQUE DIAMANT POUR BÉTON FRAIS  
/ DISCO DIAMANTADO PARA HORMIGÓN FRESCO



High performance Diamond blade with professional quality, specific for cutting asphalt.

Disque de haute rendement et qualité spécifique pour la coupe de l'asphalte.

Disco de alto rendimiento y calidad profesional específica para corte de asfalto.

High performance Diamond blade with professional quality, specific for cutting cured concrete with and without reinforcement, as well as abrasive materials.

Disque de haut rendement et qualité professionnelle pour la coupe en béton et béton armé, ainsi que en matériaux abrasifs.

Disco de alto rendimiento y de calidad profesional para corte de hormigón curado con y sin refuerzo, así como materiales abrasivos.

High performance Diamond blade with professional quality, specific for fresh concrete cutting.

Disque de haute performance et de qualité professionnelle pour la coupe de béton frais.

Disco de alto rendimiento y de calidad profesional para corte de hormigón fresco.



**CÓDIGO**  
CODE / CODE / CÓDIGO

**DIMENSÕES**  
SIZE / DIMENSIONS / MEDIDA

**EMBALAGEM**  
QUANTITY / EMBALLAGE / EMBALAJE

	A	B	C	
008360100300	300	25.4	18+3R	1
008360100350	350	25.4	20+4R	1



**CÓDIGO**  
CODE / CODE / CÓDIGO

**DIMENSÕES**  
SIZE / DIMENSIONS / MEDIDA

**EMBALAGEM**  
QUANTITY / EMBALLAGE / EMBALAJE

	A	B	C	
008350100300	300	25.4	18+3R	1
008350100350	350	25.4	20+4R	1



**CÓDIGO**  
CODE / CODE / CÓDIGO

**DIMENSÕES**  
SIZE / DIMENSIONS / MEDIDA

**EMBALAGEM**  
QUANTITY / EMBALLAGE / EMBALAJE

	A	B	C	
008330100300	300	25.4	20	1
008330100350	350	25.4	24	1



# FERRAMENTA ELETTRICA

POWER TOOLS  
OUTILLAGE ÉLECTRIQUE  
HERRAMIENTA ELÉCTRICA

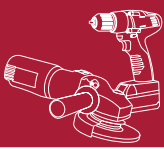

# FERRAMENTA ELÉTRICA

Power Tools / Outils Électrique / Herramienta Eléctrica

**M12 FUEL**  
DRIVEN TO OUTPERFORM.

## M12 FDD - 202X

**Aparafusadora de 2 Velocidades**  
/ 2-Speed Compact Drill Driver / Visseuse à 2 vitesses  
/ Taladro Atrornillador compacto



**FUEL**  
DRIVEN TO OUTPERFORM.



37Nm



2x2.0Ah



1.2Kg

<b>Velocidade em vazio (Velocidade 1 (rpm))</b> / No load speed gear 1 (rpm) / Vitesse à vide (Vitesse 1 (rpm)) / Velocidad en vacío 1ª Velocidad (rpm)	0 - 450
<b>Velocidade em vazio (Velocidade 2 (rpm))</b> / No load speed gear 2 (rpm) / Vitesse à vide (Vitesse 2 (rpm)) / Velocidad en vacío 2ª Velocidad (rpm)	0 - 1700
<b>Capacidade da bucha (mm)</b> / Chuck capacity (mm) / Capacité du mandrin (mm) / Capacidad de portabrocas (mm)	13
<b>Capacidade perfuração madeira (mm)</b> / Max. drilling wood (mm) / Capacité de perçage de bois (mm) / Máx. Cap. de taladrado en madera (mm)	35
<b>Capacidade perfuração aço (mm)</b> / Max. drilling steel (mm) / Capacité de perçage d'acier (mm) / Máx. Cap. de taladrado en hierro (mm)	13
<b>Fornecida em</b> / Supplied in / Fournie avec / Se suministrada en	<b>Caixa plástica</b> / Kitbox / Boite plastique / Kitbox
<b>Código</b> Code / Code / Código	001190459816

## M12 FPD - 402X

**Berbequim Combi Compacto de 2 Velocidades**  
/ 2-Speed Compact Hammer Drill / Perceuse compacte à 2 vitesses  
/ Taladro Percutor compacto



**FUEL**  
DRIVEN TO OUTPERFORM.



52Nm



2x4.0Ah



1.5Kg

<b>Velocidade em vazio (Velocidade 1 (rpm))</b> / No load speed gear 1 (rpm) / Vitesse à vide (Vitesse 1 (rpm)) / Velocidad en vacío 1ª Velocidad (rpm)	0 - 450
<b>Velocidade em vazio (Velocidade 2 (rpm))</b> / No load speed gear 2 (rpm) / Vitesse à vide (Vitesse 2 (rpm)) / Velocidad en vacío 2ª Velocidad (rpm)	0 - 1700
<b>Capacidade da bucha (mm)</b> / Chuck capacity (mm) / Capacité du mandrin (mm) / Capacidad de portabrocas (mm)	13
<b>Capacidade perfuração madeira (mm)</b> / Max. drilling wood (mm) / Capacité de perçage de bois (mm) / Máx. Cap. de taladrado en madera (mm)	35
<b>Capacidade perfuração aço (mm)</b> / Max. drilling steel (mm) / Capacité de perçage d'acier (mm) / Máx. Cap. de taladrado en hierro (mm)	13
<b>Capacidade perfuração alvenaria (mm)</b> / Max. drilling masonry (mm) / Capacité de perçage de maçonnerie (mm) / Máx. Cap. en mampostería (mm)	13
<b>Percussões (ipm)</b> / Max. percussion rate (bpm) / Percussions (cpm) / Impactos bajo carga (bpm)	25.500
<b>Fornecida em</b> / Supplied in / Fournie avec / Se suministrada en	<b>Caixa plástica</b> / Kitbox / Boite plastique / Kitbox
<b>Código</b> Code / Code / Código	001190459804

## M12 FID - 202X

**Aparafusadora Impacto 1/4" Hex**  
/ Compact 1/4" Hex Impact Driver / Visseuse À Chocs Compacte / Atrornillador Compacto De Impacto Sin Escobillas M12 Fuel™ 1/4" Hex



**FUEL**  
DRIVEN TO OUTPERFORM.



147Nm



2x2.0Ah



1.1Kg

<b>Velocidade em vazio (rpm)</b> / No load speed gear (rpm) / Vitesse à vide (rpm) / Velocidad en vacío (rpm)	0-1300 / 0-2400 / 0-3300 / 0-3300
<b>Impactos (ipm)</b> / Impact (ipm) / Impact (ipm) / Impactos (ipm)	0 - 4000
<b>Encabadouro</b> / Tool reception / Emmanchement / Eje portabrocas	1/4" Hex
<b>Fornecida em</b> / Supplied in / Fournie avec / Se suministrada en	<b>Caixa plástica</b> / Kitbox / Boite plastique / Kitbox
<b>Código</b> Code / Code / Código	001190459823



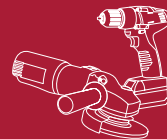

**M12**

**M12 BSD - 201C**

**Aparafusadora Compacta de Encaixe ¼" / Sub Compact Single Speed Driver / Visseuse Ultra-Compacte / Atornillador Sub-Compacto De Una Velocidad M12**

<b>Velocidade em vazio (Velocidade 1 (rpm))</b> / No load speed gear 1 (rpm) / Vitesse à vide (Vitesse 1 (rpm)) / Velocidad en vacío 1* Velocidad (rpm)	0 - 500
<b>Encabadouro</b> / Tool reception / Emmanchement / Eje portabrocas	¼" Hex
<b>Capacidade perfuração madeira (mm)</b> / Max. drilling wood (mm) / Capacité de perçage de bois (mm) / Máx. Cap. de taladrado en madera (mm)	16
<b>Capacidade perfuração aço (mm)</b> / Max. drilling steel (mm) / Capacité de perçage d'acier (mm) / Máx. Cap. de taladrado en hierro (mm)	10
<b>Fornecida em</b> / Supplied in / Fournie avec / Se suministrada en	<b>Caixa cartão / Card Box / Boite de carte / Caja de cartón</b>
<b>Código</b> Code / Code / Código	001102153110



**20Nm**  
**1x2.0Ah**  
**0.9Kg**



**M12 BDD - 202C**

**Aparafusadora de 2 velocidades / 2-Speed Screwdriver / Visseuse à 2 vitesses / Taladro Atornillador subcompacto 2 velocidades**

<b>Velocidade em vazio (Velocidade 1 (rpm))</b> / No load speed gear 1 (rpm) / Vitesse à vide (Vitesse 1 (rpm)) / Velocidad en vacío 1* Velocidad (rpm)	0 - 400
<b>Velocidade em vazio (Velocidade 2 (rpm))</b> / No load speed gear 2 (rpm) / Vitesse à vide (Vitesse 2 (rpm)) / Velocidad en vacío 2* Velocidad (rpm)	0 - 1500
<b>Capacidade da bucha (mm)</b> / Chuck capacity (mm) / Capacité du mandrin (mm) / Capacidad de portabrocas (mm)	10
<b>Capacidade perfuração madeira (mm)</b> / Max. drilling wood (mm) / Capacité de perçage de bois (mm) / Máx. Cap. de taladrado en madera (mm)	22
<b>Capacidade perfuração aço (mm)</b> / Max. drilling steel (mm) / Capacité de perçage d'acier (mm) / Máx. Cap. de taladrado en hierro (mm)	10
<b>Fornecida em</b> / Supplied in / Fournie avec / Se suministrada en	<b>Caixa plástica / Kitbox / Boite plastique / Kitbox</b>
<b>Código</b> Code / Code / Código	001102150131



**30Nm**  
**2x2.0Ah**  
**1.2Kg**



**M12 BPD - 402C**

**Berbequim Combi Compacto de 2 velocidades / 2-Speed Percussion Drill / Perceuse Compacte à 2 vitesses / Taladro Percutor subcompacto 2 velocidades**

<b>Velocidade em vazio (Velocidade 1 (rpm))</b> / No load speed gear 1 (rpm) / Vitesse à vide (Vitesse 1 (rpm)) / Velocidad en vacío 1* Velocidad (rpm)	0 - 500
<b>Velocidade em vazio (Velocidade 2 (rpm))</b> / No load speed gear 2 (rpm) / Vitesse à vide (Vitesse 2 (rpm)) / Velocidad en vacío 2* Velocidad (rpm)	0 - 1500
<b>Capacidade da bucha (mm)</b> / Chuck capacity (mm) / Capacité du mandrin (mm) / Capacidad de portabrocas (mm)	10
<b>Capacidade perfuração madeira (mm)</b> / Max. drilling wood (mm) / Capacité de perçage de bois (mm) / Máx. Cap. de taladrado en madera (mm)	22
<b>Capacidade perfuração aço (mm)</b> / Max. drilling steel (mm) / Capacité de perçage d'acier (mm) / Máx. Cap. de taladrado en hierro (mm)	10
<b>Capacidade perfuração alvenaria (mm)</b> / Max. drilling masonry (mm) / Capacité de perçage de maçonnerie (mm) / Máx. Cap. en mampostería (mm)	7
<b>Impactos (ipm)</b> / Impact (ipm) / Impact (ipm) / Impactos (ipm)	22.500
<b>Fornecida em</b> / Supplied in / Fournie avec / Se suministrada en	<b>Caixa plástica / Kitbox / Boite plastique / Kitbox</b>
<b>Código</b> Code / Code / Código	001101751131



**32Nm**  
**2x4.0Ah**  
**1.3Kg**



**M12 BDDX - 202C**

**Aparafusadora de 2 velocidades / 2-Speed Screwdriver / Visseuse à 2 vitesses / Taladro Atornillador subcompacto 2 velocidades**



<b>Velocidade em vazio (Velocidade 1 (rpm))</b> / No load speed gear 1 (rpm) / Vitesse à vide (Vitesse 1 (rpm)) / Velocidad en vacío 1* Velocidad (rpm)	0 - 400
<b>Velocidade em vazio (Velocidade 2 (rpm))</b> / No load speed gear 2 (rpm) / Vitesse à vide (Vitesse 2 (rpm)) / Velocidad en vacío 2* Velocidad (rpm)	0 - 1500
<b>Capacidade da bucha (mm)</b> / Chuck capacity (mm) / Capacité du mandrin (mm) / Capacidad de portabrocas (mm)	10
<b>Capacidade perfuração madeira (mm)</b> / Max. drilling wood (mm) / Capacité de perçage de bois (mm) / Máx. Cap. de taladrado en madera (mm)	25
<b>Capacidade perfuração aço (mm)</b> / Max. drilling steel (mm) / Capacité de perçage d'acier (mm) / Máx. Cap. de taladrado en hierro (mm)	10
<b>Fornecida em</b> / Supplied in / Fournie avec / Se suministrada en	<b>Bolsa / Bag / Sac / bolsa</b>
<b>Código</b> Code / Code / Código	001102151131



**FIX TEC**  
**32Nm**  
**2x2.0Ah**  
**1.3Kg**

**Accessórios / Accessories / Accessoires / Accesorios**



**Adaptador angular**  
/ Angle Adapter / Adaptateur d'angle / Adaptador de ángulo

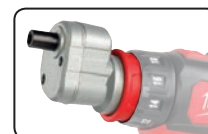

**Adaptador descentrado**  
/ Off-center adapter / Adaptateur décentré / Adaptador off-center

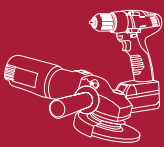

# FERRAMENTA ELÉTRICA

Power Tools / Outillage Électrique / Herramienta Eléctrica

**M12 FUEL**  
DRIVEN TO OUTPERFORM.

## M12 CHZ - 202C

Serra de Sabre Compacta / Compact Hackzall / Scie sabre 1 main / Sierra De Sable Hackzall™ Sin Escobillas

<b>Velocidade em vazio (rpm)</b> / No load speed gear (rpm) / Vitesse à vide (rpm) / Velocidad en vacío (rpm)	0 - 3000
<b>Curso da lâmina (mm)</b> / Supplied in / Fournie avec / Se suministrada en	16
<b>Fornecida em</b> / Supplied in / Fournie avec / Se suministrada en	<b>Saco de transporte / Kitbox /</b> Boîte plastique / Bolsa de transporte
<b>Código</b> Code / Code / Código	001102801120

**2x2.0Ah**  
 **1.56Kg**



**FUEL**  
DRIVEN TO OUTPERFORM.

**M12**

## C12 MT - 202B

Multi-ferramenta  
/ Multi-Tool / Outil Multifonction / Multiherramienta

**2x2.0Ah**  
 **1.0Kg**



<b>Ângulo de oscilação esquerda/ direita (°)</b> / Oscillation angle left/ right (°) / Angle d'oscillation gauche/ droite (°) / Ángulo de oscilación izquierda/ derecha (°)	1.5
<b>Velocidade em vazio (rpm)</b> / No load speed gear (rpm) / Vitesse à vide (rpm) / Velocidad en vacío (rpm)	5.000 - 20.000
<b>Fornecida em</b> / Supplied in / Fournie avec / Se suministrada en	<b>Saco de transporte / Kitbox /</b> Boîte plastique / Bolsa de transporte
<b>Código</b> Code / Code / Código	001102206978

## M12 PCG - 201B

Pistola para Selantes  
/ Caulk Gun / Pistolet à Mastics / Pistola de calafatear

**1x2.0Ah**  
 **1.9Kg**



<b>Capacidade das baterias (Ah)</b> / Battery capacity (Ah) / Capacité de la batterie (Ah) / Capacidad de la batería (Ah)	2.0
<b>Fornecida em</b> / Supplied in / Fournie avec / Se suministrada en	<b>Saco de transporte / Kitbox /</b> Boîte plastique / Bolsa de transporte
<b>Código</b> Code / Code / Código	001102150124

## Sistemas de Medição

Measuring systems / Systèmes de mesure / Sistemas de medición

## IC AV3 - 201C

Câmara Inspeção / Spector Camera / Cámara  
d'Inspection Digitale / Cámara de Inspección

**M12**

**1x2.0Ah**  
 **0.6Kg**



<b>Tamanho ecrã (mm)</b> / Display size (mm) / Taille de l'écran (mm) / Tamaño de la pantalla (mm)	85
<b>Resolução do ecrã (pixels)</b> / Display resolution / Résolution de l'affichage / Resolución de la pantalla	640x320
<b>Diâmetro do cabo-câmara (mm)</b> / Camera head diameter (mm) / Diamètre du câble-caméra (mm) / Diámetro del cabezal de la cámara (mm)	12.5
<b>Fornecida em</b> / Supplied in / Fournie avec / Se suministrada en	<b>Caixa plástica</b> / Kitbox / Boîte plastique / Kitbox
<b>Código</b> Code / Code / Código	001190451367

## LDM 45

Medidor distâncias laser / Laser Distance Meter  
/ Lasermètres / Medidor láser de distancia



<b>Máx. gama de medição (m)</b> / Max. measuring range (m) / Max. Plage de mesure (m) / Max. Rango de medición (m)	31.5 x 40
<b>Tamanho ecrã (mm)</b> / Display size (mm) / Taille de l'écran (mm) / Tamaño de la pantalla (mm)	640x320
<b>Diâmetro do cabo-câmara (mm)</b> / Camera head diameter (mm) / Diamètre du câble-caméra (mm) / Diámetro del cabezal de la cámara (mm)	12.5
<b>Fornecida em</b> / Supplied in / Fournie avec / Se suministrada en	<b>Caixa plástica</b> / Kitbox / Boîte plastique / Kitbox
<b>Código</b> Code / Code / Código	001190451367





# FUEL™

ATÉ  
**10** VEZES  
**MAIOR**  
DURABILIDADE

Up To 10X Longer Life  
/ Jusqu'à 10 Fois Plus Grande Durabilité  
/ Hasta 10 Veces Mayor Durabilidad

ATÉ  
**2** VEZES  
**MAIS**  
AUTONOMIA

Up To 2X More Run Time  
/ Jusqu'à 2 Fois Plus D'autonomie  
/ Hasta 2 Veces Más Autonomía

ATÉ  
**2** VEZES  
**MAIS**  
POTÊNCIA

Up to 2x more power  
/ Jusqu'à 2 fois plus de puissance  
/ Hasta 2 veces más potencia



## Motor sem escovas POWERSTATE™

POWERSTATE™ Brushless Motor  
/ POWERSTATE™ Le moteur sans charbon  
/ Motor Sin Escobillas POWERSTATE™

- **Motor sem escovas** / Milwaukee® designed and built brushless motor / Moteur conçu et fabriqué par Milwaukee® / Motor sin escobillas diseñado y construido por Milwaukee;
- **Desempenho mais elevado do que os seus concorrentes** / Out-performs all leading competitors / Le plus performant de la catégorie / Mayor rendimiento que sus competidores;
- **10 vezes mais duráveis** / Up to 10x longer motor life / Durée de vie multipliée par 10 / 10 veces más duradero.



## Eletrónica Inteligente REDLINK PLUS™

REDLINK PLUS™ Intelligence  
/ REDLINK PLUS™ L'intelligence  
/ Electrónica Inteligente REDLINK PLUS™

- **A eletrónica mais avançada do mercado, oferecendo um rendimento único** / Most advanced system electronics in cordless power tools with unique digital performance enhancement / L'électronique la plus "intelligente" / La electrónica más avanzada del mercado, ofreciendo un rendimiento digitalizado único;
- **Integração total do sistema com proteção contra a sobrecarga que incrementa a vida da bateria** / Total system communication with overload protection increases tool life / Régule et optimise le rendement de la batterie et du moteur en fonction de l'utilisation. Protection intégrale contre les surcharges, les surchauffes, les décharges totales / Comunicación total del sistema con protección contra la sobrecarga que incrementa la vida de la batería y de la máquina



## Bateria REDLITHIUM-ION™

REDLITHIUM-ION™ Battery Packs  
/ Technologie REDLITHIUM-ION™  
/ Bateria REDLITHIUM-ION™

- **A bateria mais duradoura do mercado** / Most durable pack on the market / La meilleure durée de vie des batteries Li-Ion / La batería más duradera del mercado;
- **Possui o dobro da autonomia** / Up to 2x more run time / Jusqu'à 2 fois plus d'autonomie / El doble de autonomía;
- **Indicador de carga incorporado** / Fuel gauge displays remaining charge / Échelle lumineuse de l'autonomie disponible / Indicador de carga incorporado;
- **Funciona a -18 °C** / Operates down to -20 °C / Fonctionne jusqu'à -18 °C / Funciona hasta -18°C;
- **Monitorização individual das células que otimiza a autonomia e assegura a durabilidade da bateria** / Individual cell monitoring to optimise tool run time and ensure long term pack durability / Gestion électronique individualisée des cellules pour une durée de vie accrue et une autonomie incomparable / Monitorización individual de las células que optimiza la autonomía y asegura la durabilidad de la batería



**FUEL**  
DRIVEN TO OUTPERFORM.™



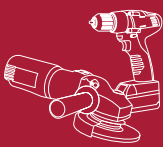

# FERRAMENTA ELÉTRICA

Power Tools / Outillage Électrique / Herramienta Eléctrica



ONEKEY  
UNLOCKING THE DIGITAL JOBSITE



# ONEKEY™

## UNLOCKING THE DIGITAL JOBSITE™



### 1 M18 FUEL FERRAMENTA INTELIGENTE

A nova geração de ferramentas FUEL com tecnologia Bluetooth integrada

### 2 SINCRONIZAÇÃO SEM FIOS E CONTROLO DA MÁQUINA

Comunicação sem fios para personalizar a sua ferramenta através da aplicação para Android e iOS

### 3 GESTÃO DO INVENTÁRIO COM O SEU SMARTPHONE + COMPUTADOR

Controle o seu stock, não só de Milwaukee mas de todo o seu parque de máquinas

1 / Smart tool. The new generation of tools FUEL with integrated Bluetooth technology / L'outil Smart. La nouvelle génération d'outils carburant avec technologie Bluetooth intégré / Herramienta inteligente. Nueva generación de herramienta FUEL con tecnología de control inteligente por Bluetooth

2 / Wireless synchronization and control of the machine. Wireless communication to customize your tool through the application for Android and iOS / La synchronisation sans fil et le contrôle de la machine. La communication sans fil pour personnaliser votre outil par le biais de l'application pour Android et iOS / Sincronización sin cable y control de la herramienta. Comunicación inalámbrica para personalizar la herramienta a través de aplicaciones de Android o iOS.

3 / Inventory Management with your smartphone + computer. Control your stock, not only in Milwaukee but of your entire fleet of machinery / Gestion d'inventaires avec votre smartphone + ordinateur. Contrôler votre stock, non seulement à Milwaukee, mais de l'ensemble de votre parc de machines / Control de inventario con el móvil y ordenador. Controla tus herramientas, no sólo de Milwaukee sino todas la maquinaria y accesorios que tengas en stock.

### M18 ONEDD - 502X

#### Aparafusadora 18V

/ Compact Drill Driver 18V / Visseuse à 2 vitesses 18V / Taladro Atornillador compacto 18V



ONEKEY  
UNLOCKING THE DIGITAL JOBSITE  
FUEL  
DRIVEN TO OUTPERFORM.

135Nm  
2x5.0Ah  
2.5Kg

Velocidade em vazio (Velocidade 1 (rpm)) / No load speed gear 1 (rpm) / Vitesse à vide (Vitesse 1 (rpm)) / Velocidad en vacío 1ª Velocidad (rpm)	0 - 550
Velocidade em vazio (Velocidade 2 (rpm)) / No load speed gear 2 (rpm) / Vitesse à vide (Vitesse 2 (rpm)) / Velocidad en vacío 2ª Velocidad (rpm)	0 - 2000
Capacidade da bucha (mm) / Chuck capacity (mm) / Capacité du mandrin (mm) / Capacidad de portabrocas (mm)	13
Capacidade perfuração madeira (mm) / Max. drilling wood (mm) / Capacité de perçage de bois (mm) / Máx. Cap. de taladrado en madera (mm)	45
Capacidade perfuração aço (mm) / Max. drilling steel (mm) / Capacité de perçage d'acier (mm) / Máx. Cap. de taladrado en hierro (mm)	13
Fornecida em / Supplied in / Fournie avec / Se suministrada en	Caixa DYNACASE / Dyna Case / Boite plastique / Kitbox
Código Code / Code / Código	M18 ONEDD - 502X 001190451149
Código Code / Code / Código	M18 FDD - 502X 001190451064

### M18 ONEPD - 502X

#### Berbequim Combi 18V

/ Percussion Drill 18V / Perceuse À Percussion 18V / Taladro Percutor 18V



ONEKEY  
UNLOCKING THE DIGITAL JOBSITE  
FUEL  
DRIVEN TO OUTPERFORM.

135Nm  
2x5.0Ah  
2.5Kg

Velocidade em vazio (Velocidade 1 (rpm)) / No load speed gear 1 (rpm) / Vitesse à vide (Vitesse 1 (rpm)) / Velocidad en vacío 1ª Velocidad (rpm)	0 - 550
Velocidade em vazio (Velocidade 2 (rpm)) / No load speed gear 2 (rpm) / Vitesse à vide (Vitesse 2 (rpm)) / Velocidad en vacío 2ª Velocidad (rpm)	0 - 2000
Capacidade da bucha (mm) / Chuck capacity (mm) / Capacité du mandrin (mm) / Capacidad de portabrocas (mm)	13
Capacidade perfuração madeira (mm) / Max. drilling wood (mm) / Capacité de perçage de bois (mm) / Máx. Cap. de taladrado en madera (mm)	45
Capacidade perfuração aço (mm) / Max. drilling steel (mm) / Capacité de perçage d'acier (mm) / Máx. Cap. de taladrado en hierro (mm)	13
Capacidade perfuração alvenaria (mm) / Max. drilling masonry (mm) / Capacité de perçage de maçonnerie (mm) / Máx. Cap. en mampostería (mm)	13
Impactos (ipm) / Supplied in / Fournie avec / Se suministrada en	0 - 32000
Fornecida em / Supplied in / Fournie avec / Se suministrada en	Caixa DYNACASE / Dyna Case / Boite plastique / Kitbox
Código Code / Code / Código	M18 ONEPD - 502X 001190451147
Código Code / Code / Código	M18 FPD - 502X 001190451061



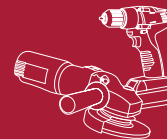

**M18 BRUSHLESS**

**M18 BLDD - 502C**

**Aparafusadora Brushless (sem escovas)**  
+Compact Brushless Drill Driver / Compact Brushless Drill Driver / Atornillador Compacto Brushless



60Nm



2x5.0Ah



1.7Kg

<b>Velocidade em vazio (Velocidade 1 (rpm))</b> / No load speed gear 1 (rpm) / Vitesse à vide (Vitesse 1 (rpm)) / Velocidad en vacío 1ª Velocidad (rpm)	0 - 450
<b>Velocidade em vazio (Velocidade 2 (rpm))</b> / No load speed gear 2 (rpm) / Vitesse à vide (Vitesse 2 (rpm)) / Velocidad en vacío 2ª Velocidad (rpm)	0 - 1800
<b>Capacidade da bucha (mm)</b> / Chuck capacity (mm) / Capacité du mandrin (mm) / Capacidad de portabrocas (mm)	13
<b>Capacidade perfuração madeira (mm)</b> / Max. drilling wood (mm) / Capacité de perçage de bois (mm) / Máx. Cap. de taladrado en madera (mm)	38
<b>Capacidade perfuração aço (mm)</b> / Max. drilling steel (mm) / Capacité de perçage d'acier (mm) / Máx. Cap. de taladrado en hierro (mm)	13
<b>Fornecida em</b> / Supplied in / Fournie avec / Se suministrada en	<b>Caixa plástica</b> / Kitbox / Boite plastique / Kitbox
<b>Código</b> Code / Code / Código	001190448458

**M18 BLPD - 502C**

**Berbequim Combi Brushless (sem escovas)**  
/ Percussion Drill 18V Brushless / Perceuse À Percussion 18V Brushless / Taladro Percutor 18V Brushless



60Nm



2x5.0Ah



1.8Kg

<b>Velocidade em vazio (Velocidade 1 (rpm))</b> / No load speed gear 1 (rpm) / Vitesse à vide (Vitesse 1 (rpm)) / Velocidad en vacío 1ª Velocidad (rpm)	0 - 550
<b>Velocidade em vazio (Velocidade 2 (rpm))</b> / No load speed gear 2 (rpm) / Vitesse à vide (Vitesse 2 (rpm)) / Velocidad en vacío 2ª Velocidad (rpm)	0 - 1800
<b>Capacidade da bucha (mm)</b> / Chuck capacity (mm) / Capacité du mandrin (mm) / Capacidad de portabrocas (mm)	13
<b>Capacidade perfuração madeira (mm)</b> / Max. drilling wood (mm) / Capacité de perçage de bois (mm) / Máx. Cap. de taladrado en madera (mm)	50
<b>Capacidade perfuração aço (mm)</b> / Max. drilling steel (mm) / Capacité de perçage d'acier (mm) / Máx. Cap. de taladrado en hierro (mm)	13
<b>Capacidade perfuração alvenaria (mm)</b> / Max. drilling masonry (mm) / Capacité de perçage de maçonnerie (mm) / Máx. Cap. en mampostería (mm)	8
<b>Impactos (ipm)</b> / Impact (ipm) / Impact (ipm) / Impactos (ipm)	28,800
<b>Fornecida em</b> / Supplied in / Fournie avec / Se suministrada en	<b>Caixa plástica</b> / Kitbox / Boite plastique / Kitbox
<b>Código</b> Code / Code / Código	001190448472

**M18**

**M18 BDD - 202C**

**Aparafusadora de 2 Velocidades**  
/ Compact Drill Driver / Visseuse à 2 vitesses / Taladro Atornillador Compacto



50Nm



2x2.0Ah



1.8Kg

<b>Velocidade em vazio (Velocidade 1 (rpm))</b> / No load speed gear 1 (rpm) / Vitesse à vide (Vitesse 1 (rpm)) / Velocidad en vacío 1ª Velocidad (rpm)	0 - 450
<b>Velocidade em vazio (Velocidade 2 (rpm))</b> / No load speed gear 2 (rpm) / Vitesse à vide (Vitesse 2 (rpm)) / Velocidad en vacío 2ª Velocidad (rpm)	0 - 1800
<b>Capacidade da bucha (mm)</b> / Chuck capacity (mm) / Capacité du mandrin (mm) / Capacidad de portabrocas (mm)	13
<b>Capacidade perfuração madeira (mm)</b> / Max. drilling wood (mm) / Capacité de perçage de bois (mm) / Máx. Cap. de taladrado en madera (mm)	38
<b>Capacidade perfuração aço (mm)</b> / Max. drilling steel (mm) / Capacité de perçage d'acier (mm) / Máx. Cap. de taladrado en hierro (mm)	13
<b>Fornecida em</b> / Supplied in / Fournie avec / Se suministrada en	<b>Caixa plástica</b> / Kitbox / Boite plastique / Kitbox
<b>Código</b> Code / Code / Código	001102150190

**M18 BPD - 402C**

**Berbequim Combi de 2 velocidades**  
/ Compact Percussion Drill / Perceuse/Visseuse à 2 vitesses / Taladro percutor compacto



60Nm



2x4.0Ah



1.5Kg

<b>Velocidade em vazio (Velocidade 1 (rpm))</b> / No load speed gear 1 (rpm) / Vitesse à vide (Vitesse 1 (rpm)) / Velocidad en vacío 1ª Velocidad (rpm)	0 - 450
<b>Velocidade em vazio (Velocidade 2 (rpm))</b> / No load speed gear 2 (rpm) / Vitesse à vide (Vitesse 2 (rpm)) / Velocidad en vacío 2ª Velocidad (rpm)	0 - 1800
<b>Capacidade da bucha (mm)</b> / Chuck capacity (mm) / Capacité du mandrin (mm) / Capacidad de portabrocas (mm)	13
<b>Capacidade perfuração madeira (mm)</b> / Max. drilling wood (mm) / Capacité de perçage de bois (mm) / Máx. Cap. de taladrado en madera (mm)	38
<b>Capacidade perfuração aço (mm)</b> / Max. drilling steel (mm) / Capacité de perçage d'acier (mm) / Máx. Cap. de taladrado en hierro (mm)	13
<b>Capacidade perfuração alvenaria (mm)</b> / Max. drilling masonry (mm) / Capacité de perçage de maçonnerie (mm) / Máx. Cap. en mampostería (mm)	13
<b>Impactos (ipm)</b> / Impact (ipm) / Impact (ipm) / Impactos (ipm)	28,800
<b>Fornecida em</b> / Supplied in / Fournie avec / Se suministrada en	<b>Caixa plástica</b> / Kitbox / Boite plastique / Kitbox
<b>Código</b> Code / Code / Código	001102150191

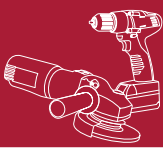

# FERRAMENTA ELÉTRICA

Power Tools / Outillage Électrique / Herramienta Eléctrica

**M18 FUEL**  
DRIVEN TO OUTPERFORM.

## M18 CHX - 502X

Martelo 4 Modos SDS-Plus / SDS-Plus Hammer / Perfo-burineur SDS-Plus / Martillo SDS-Plus Sin Escobillas

<b>Encabadouro</b> / Tool reception / Emmanchement / Eje portabrocas	SDS-Plus
<b>Energia de impacto (EPTAI(J))</b> / Blow energy (EPTAI(J)) / Force de frappe (EPTAI(J)) / Energía de impacto (EPTAI(J))	2.5
<b>Capacidade perfuração madeira (mm)</b> / Max. drilling wood (mm) / Capacité de perçage de bois (mm) / Máx. Cap. de taladrado en madera (mm)	30
<b>Capacidade perfuração aço (mm)</b> / Max. drilling steel (mm) / Capacité de perçage d'acier (mm) / Máx. Cap. de taladrado en hierro (mm)	13
<b>Capacidade perfuração betão (mm)</b> / Max. drilling concrete (mm) / Capacité de perçage de béton (mm) / Máx. Cap. de taladrado en hormigón (mm)	26
<b>Vibração (m/s<sup>2</sup>)</b> / Vibration (m/s <sup>2</sup> ) / Vibración (m/s <sup>2</sup> )	8.9
<b>Fornecida em</b> / Supplied in / Fournie avec / Se suministrada en	<b>Caixa DYNACASE</b> / Kitbox / Boite plastique / Kitbox
<b>Código</b> Code / Code / Código	001190451381
<b>2x5.0Ah</b>	<b>3.5Kg</b>
<b>J</b>	<b>2.5</b>

**FUEL**  
DRIVEN TO OUTPERFORM.



## M18 CHM - 902C

## Martelo Combinado SDS-MAX

/ 5 Kg SDS-Max Drilling And Breaking Hammer / Marteau Perforateur SDS Max / Martillo Combinado 5 Kg SDS-Max

<b>Encabadouro</b> / Tool reception / Emmanchement / Eje portabrocas	SDS-Max
<b>Energia de impacto (EPTAI(J))</b> / Impact energy (EPTAI(J)) / L'énergie de l'impact (EPTAI(J)) / La energía del impacto (EPTAI(J))	6.1
<b>Ação de Percussão em Plena Carga (bpm)</b> / Action of percussion at Full Load (bpm) / Action de percussion à pleine charge (bpm) / La acción de la percusión a plena carga (bpm)	0 - 3000
<b>Velocidade em vazio (rpm)</b> / No load speed gear (rpm) / Vitesse à vide (rpm) / Velocidad en vacío (rpm)	0 - 450
<b>Max. capacidade de furação em betão (mm)</b> / Max. drilling concrete (mm) / Capacité de perçage de béton (mm) / Máx. Cap. de taladrado en hormigón (mm)	40
<b>Max. capacidade de furação com broca de perfuração (mm)</b> / Max. drilling tunnel bit (mm) / Max. Capacité de percer les trous avec un foret de perçage (mm) / Máx. capacidad de taladrado con broca túnel	65
<b>Max. Capacidade de furação com broca craneana para betão (mm)</b> / Max. drilling core bit (mm) / Maximum de perçage avec une scie trépan béton (mm) / Máx. capacidad de taladrado con corona (mm)	100
<b>Vibração em perfuração (m/s<sup>2</sup>)</b> / Vibration in drilling (m/s <sup>2</sup> ) / Vibration dans le forage (m/s <sup>2</sup> ) / La vibración en la perforación (m/s <sup>2</sup> )	5.5
<b>Vibração de cinzelado (m/s<sup>2</sup>)</b> / Vibration of chiselled (m/s <sup>2</sup> ) / La vibration d'ciselait (m/s <sup>2</sup> ) / Vibración de cincelado (m/s <sup>2</sup> )	3.1
<b>Fornecida em</b> / Supplied in / Fournie avec / Se suministrada en	<b>Caixa plástica</b> / Kitbox / Boite plastique / Kitbox
<b>Código</b> Code / Code / Código	001190451361

**FUEL**  
DRIVEN TO OUTPERFORM.



**2x9.0Ah** **6.6Kg** **J**

## M18 FID - 502X

## Aparafusadora Impacto 1/4" Hex

/ 1/4" Hex Compact Impact Driver / Clé à choc 1/4" Hex / Atornillador de Impacto 1/4" Hex

**FUEL**  
DRIVEN TO OUTPERFORM.



<b>Velocidade em vazio (rpm)</b> / No load speed gear (rpm) / Vitesse à vide (rpm) / Velocidad en vacío (rpm)	850/2100/3000
<b>Impactos (ipm)</b> / Impact (ipm) / Impact (ipm) / Impactos (ipm)	1800/2900/3700
<b>Encabadouro</b> / Tool reception / Emmanchement / Eje portabrocas	1/4" Hex
<b>Fornecida em</b> / Supplied in / Fournie avec / Se suministrada en	<b>Caixa DYNACASE</b> / Kitbox / Boite plastique / Kitbox
<b>Código</b> Code / Code / Código	001190451066

**12/80/203Nm** **2x5.0Ah** **1.5Kg**

## M18 FSGC - 202X

## Aparafusadora p/ Gesso Cartonado

/ Drywall Screw Gun / Visseuse plaquiste sans fil / Atornillador cartón yeso

**FUEL**  
DRIVEN TO OUTPERFORM.



<b>Velocidade em vazio (rpm)</b> No load speed gear (rpm) / Vitesse à vide (rpm) / Velocidad en vacío (rpm)	5000
<b>Nº parafusos/bateria 2.0Ah</b> Amount of screws per 2.0Ah battery / Numéro de vis par batterie 2.0Ah / Cantidad de tornillos por la batería 2.0Ah	> 2000
<b>Fornecida em</b> Supplied in / Fournie avec / Se suministrada en	<b>Caixa DYNACASE</b> / Kitbox / Boite plastique / Kitbox
<b>Código</b> Code / Code / Código	001190286622

**30Nm** **2x2.0Ah** **1.5Kg** **4.2 x 22-55 mm**

## IDEAL PARA PARAFUSOS AUTO-ROSCANTES

Ideal for Self-Tapping Screws / Idéal pour Vis Autotaraudeuses / Ideal para Tornillos Autorroscantes

<p><b>FASE 1</b> Phase 1 / Fase 1</p> <p><b>Aceleração gradual da velocidade - 3000 rpm</b> / Gradual speed acceleration - 3000 rpm / Accélération progressive de la vitesse - 3000 rpm / Aceleración gradual de la velocidad - 3000 rpm</p> <p><b>Maior Precisão</b> / Greater accuracy / Plus grande précision / Mayor precisión</p>	<p><b>FASE 2</b> Phase 2 / Fase 2</p> <p><b>Velocidade rápida - 3000 rpm</b> / Fast speed - 3000 rpm / Vitesse rapide - 3000 rpm / Velocidad rápida - 3000 rpm</p> <p><b>Para melhorar a performance e a capacidade perfuração</b> / To improve the performance and drilling / Pour améliorer les performances et de forage / Para mejorar el rendimiento y la perforación</p>	<p><b>FASE 3</b> Phase 3 / Fase 3</p> <p><b>Velocidade controlada - 750 rpm</b> / Controlled speed - 750 rpm / Vitesse commandée - 750 rpm / Velocidad controlada - 750 rpm</p> <p><b>Reduz danos na cabeça do parafuso</b> - Para ao sentir o aperto final do PF / Réduit les dommages sur la tête de vis - s'arrête à la sensation de serrage final du PF / Reduce los daños en la cabeza del tornillo - se detiene al sentir el apriete final del PF</p>
--	--	---



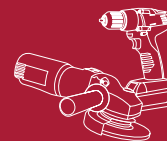

**M18**

**M18 BSX - 402C**

Serra de Sabre / Hackzall / Scie Sabre / Sierra de Sable

Núm. de golpes por minuto (gpm) / Number of strokes per minute (spm) / Nombre de coups par minute (cpm) / Número de golpes por minuto (gpm)	0 - 3000
Comprimento do curso (mm) / Stroke length (mm) / Longueur de la course (mm) / Longitud del trazo (mm)	28.6
Fornecida em / Supplied in / Fournie avec / Se suministrada en	Caixa plástica / Kitbox / Boite plastique / Kitbox
Código Code / Code / Código	001102818003

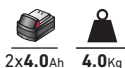

**M18 BMS20/0**

Tesoura Corte Chapa / Sheet-Metal Shears / Ciseaux Coupent / Tijera Recortadora de Chapa

Velocidade em vazio (rpm) / No load speed gear (rpm) / Vitesse à vide (rpm) / Velocidad en vacío (rpm)	0 - 2500
Raio mínimo de corte (mm) / Minimum radius of cut (mm) / Rayon minimum de coupe (mm) / Radio mínimo de corte (mm)	180
Capacidade max. corte Alu (mm) / Maximum capacity aluminum cutting (mm) / Capacité maximale de coupe en aluminium (mm) / Capacidad máxima de corte de aluminio (mm)	3.2
Capacidade max. corte Aço (mm) / Maximum capacity steel cutting (mm) / Capacité maximale de coupe en acier (mm) / Capacidad máxima de corte de acero (mm)	2.0
Fornecida em / Supplied in / Fournie avec / Se suministrada en	Caixa DYNACASE / Kitbox / Boite plastique / Kitbox
Código Code / Code / Código	001100447935



**M18 ONEFHIWF12**

Chave de Impacto 1/2"  
/ High Impact Wrench 1/2" / Clé à Choc 1/2" Carré / Llave Impacto 1/2"

**M18 ONEFHIWF34**

Chave de Impacto 3/4"  
/ High Impact Wrench 3/4" / Clé à Choc 3/4" Carré / Llave Impacto 3/4"

**FUEL**  
DRIVEN TO OUTPERFORM.

**FUEL**  
DRIVEN TO OUTPERFORM.

Velocidade em vazio (rpm) / No load speed gear (rpm) / Vitesse à vide (rpm) / Velocidad en vacío (rpm)	0 - 550 / 0 - 1400 / 0 - 1750 / 0 - 1750
---	---

Impactos (ipm) / Impact (ipm) / Impact (ipm) / Impactos (ipm)	0 - 950 / 0 - 1750 / 0 - 2100 / 0 - 2100
--	---

Encabadouro / Tool reception / Emmanchement / Eje portabrocas	1/2" quadrado
--	---------------

Fornecida em / Supplied in / Fournie avec / Se suministrada en	Caixa plástica / Kitbox / Boite plastique / Kitbox
---	---

Código Code / Code / Código	001190459696
--------------------------------	--------------



Velocidade em vazio (rpm) / No load speed gear (rpm) / Vitesse à vide (rpm) / Velocidad en vacío (rpm)	0 - 800 / 0 - 1300 / 0 - 1800 / 0 - 1800
---	---

Impactos (ipm) / Impact (ipm) / Impact (ipm) / Impactos (ipm)	0 - 850 / 0 - 1850 / 0 - 2400 / 0 - 2400
--	---

Encabadouro / Tool reception / Emmanchement / Eje portabrocas	3/4" quadrado
--	---------------

Fornecida em / Supplied in / Fournie avec / Se suministrada en	Caixa plástica / Kitbox / Boite plastique / Kitbox
---	---

Código Code / Code / Código	001190459730
--------------------------------	--------------



**M18 CHIWF12 / 34**

**RED LITHIUM-ION**



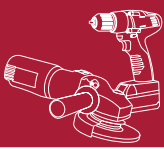

# FERRAMENTA ELÉTRICA

Power Tools / Outils Électrique / Herramienta Eléctrica

## M18 FUEL

DRIVEN TO OUTPERFORM.

### M18 CAG-125X - 502X

### Rebarbadora 125mm

/ Brushless Cordless Grinder 125mm  
/ Meuleuse D'angle 125mm / Amoladora Angular 125mm

FUEL  
DRIVEN TO OUTPERFORM.



2x5.0Ah 2.7Kg

Velocidade em vazio (rpm) / No load speed gear (rpm) / Vitesse à vide (rpm) / Velocidad en vacío (rpm)	8500
Diâmetro do prato (mm) / Disc diameter (mm) / Diamètre du disque (mm) / Diámetro del disco (mm)	125
Diâmetro do veio / Spindle size / Arbre / Tamaño del eje	M 14
Fornecida em / Supplied in / Fournie avec / Se suministrada en	Caixa plástica / Kitbox / Boite plastique / Kitbox
Código Code / Code / Código	001190448864

### M18 FAP180 - 502X

### Polidora FUEL / Polisher / Polisseur / Pulidora

FUEL  
DRIVEN TO OUTPERFORM.



2x5.0Ah 2.2Kg

Velocidade em vazio (rpm) / No load speed gear (rpm) / Vitesse à vide (rpm) / Velocidad en vacío (rpm)	360-2200
Diâmetro do prato (mm) / Disc diameter (mm) / Diamètre du disque (mm) / Diámetro del disco (mm)	180
Diâmetro do veio / Spindle size / Arbre / Tamaño del eje	M 14
Fornecida em / Supplied in / Fournie avec / Se suministrada en	Caixa plástica / Kitbox / Boite plastique / Kitbox
Código Code / Code / Código	001190451550

## Sistemas de Iluminação

Lighting systems / Les systèmes d'éclairage / Sistemas de iluminación

### Projetor HSAL-0

/ Work Light HSAL-0 / Projecteur HSAL-0 / Proyector HSAL-0

M18  
IP54



8.3Kg

HÍBRIDO  
Hybrid / hybride / híbrido  
Elétrico / électrique / eléctrico  
Bateria / Battery / batterie / batería

Voltagem (V) / Voltage (V) / Tension (V) / La tensión (V)	18 / 230
Luminosidade máxima (Lumens) / Maximum brightness (Lumens) / Maximum de luminosité (lumens) / Brillo máximo (lúmenes)	3000
Fornecida em / Supplied in / Fournie avec / Se suministrada en	Caixa cartão / Card Box / Boite de carte / Caja de cartón
Código Code / Code / Código	001190451392

### Barra iluminação capot UHL-0 / LED Underhood Light

UHL-0 / Baladeuse LED pour capot UHL-0 / Luz LED capó UHL-0

M12  
IP54



1.1Kg

Voltagem (V) / Voltage (V) / Tension (V) / La tensión (V)	12
Luminosidade máxima (Lumens) / Maximum brightness (Lumens) / Maximum de luminosité (lumens) / Brillo máximo (lúmenes)	1350/-/600/-
Fornecida em / Supplied in / Fournie avec / Se suministrada en	Caixa cartão / Card Box / Boite de carte / Caja de cartón
Código Code / Code / Código	001190459432



### Foco Híbrido HAL-0

/ Hybrid Focus HAL-0 / Focus Hybride HAL-0 / Enfoque Híbrido HAL-0

M18  
IP54

3.54Kg

HÍBRIDO  
Hybrid / hybride / híbrido  
Elétrico / électrique / eléctrico  
Bateria / Battery / batterie / batería



Voltagem (V) / Voltage (V) / Tension (V) / La tensión (V)	18
Luminosidade máxima (Lumens) / Maximum brightness (Lumens) / Maximum de luminosité (lumens) / Brillo máximo (lúmenes)	3000/1500/650
Fornecida em / Supplied in / Fournie avec / Se suministrada en	Caixa cartão / Card Box / Boite de carte / Caja de cartón
Código Code / Code / Código	001190451262

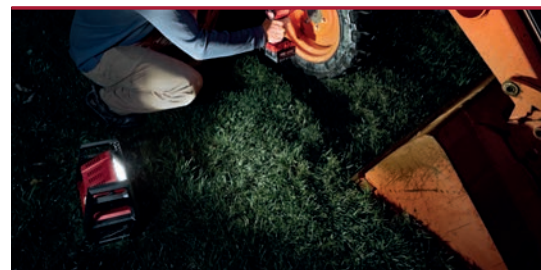

### ONESLSP

M18 IP54



5.4Kg

Voltagem (V) / Voltage (V) / Tension (V) / La tensión (V)	18
Luminosidade máxima (Lumens) / Maximum brightness (Lumens) / Maximum de luminosité (lumens) / Brillo máximo (lúmenes)	4400 / 2100 / 1000 / -
Fornecida em / Supplied in / Fournie avec / Se suministrada en	Caixa cartão / Card Box / Boite de carte / Caja de cartón
Código Code / Code / Código	001190459155



### Foco de área compacto LED ONE-KEY™ / RADIUS™ LED Compact Site Light w/ ONE-KEY™ / Eclairage de chantier One-Key™ 360° LED / Foco de área compacto LED ONE-KEY™

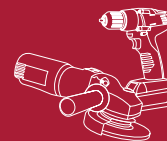

## Martelos Combinados

Breaking Hammer / Marteaux Combinés / Martillo Combinado

PH 26

**Martelo Eletropneumático SDS-Plus**  
/ 26 mm SDS-Plus 3-Mode Hammer / Marteau Perforateur  
/ Burineur SDS-Plus / Martillo SDS-Plus con 3 Modos



**725W** **2.4Kg** **2.4**

KANGO 540 S

**Martelo Combinado 5 Kg**  
/ 5 Kg Class Drilling and Breaking Hammer / Marteau Combiné 5 Kg  
/ Martillo Combinado 5 Kg



**1100W** **6.3Kg** **7.5**

<b>Energia de impacto (EPTA)(J)</b> / Blow energy (EPTA)(J) / Force de frappe (EPTA)(J) / Energía del impacto (EPTA)(J)	2.4
<b>Impactos (ipm)</b> / Impact (ipm) / Impact (ipm) / Impactos (ipm)	0 - 4500
<b>Velocidade em vazio (rpm)</b> / No load speed (rpm) / Vitesse à vide (rpm) / Velocidad en vacío (rpm)	0 - 1250
<b>Capacidade de furação betão - brocas (mm)</b> / Max. drilling concrete (mm) / Capacité de perçage de béton (mm) / Máx. capacidad de taladrado en hormigón (mm)	26
<b>Capacidade de furação metal (mm)</b> / Max. drilling steel (mm) / Capacité de perçage de métal (mm) / Máx. capacidad de taladrado en hierro (mm)	13
<b>Capacidade de furação madeira (mm)</b> / Max. drilling wood (mm) / Capacité de perçage de bois (mm) / Máx. capacidad de taladrado en madera (mm)	30
<b>Encabadouro</b> / Tool reception / Emmanchement / Eje portabrocas	SDS-Plus
<b>Nível de vibração em furação (m/s<sup>2</sup>)</b> / Vibration drilling (m/s <sup>2</sup> ) / Niveau de vibration en perçage (m/s <sup>2</sup> ) / Vibración de taladrado (m/s <sup>2</sup> )	13.5
<b>Nível de vibração em cinzelagem (m/s<sup>2</sup>)</b> / Vibration chiseling (m/s <sup>2</sup> ) / Niveau de vibration en burinage (m/s <sup>2</sup> ) / Vibración de cincelado (m/s <sup>2</sup> )	8.5
<b>Bucha FIXTEC</b> / FIXTEC / Mandrín FIXTEC / FIXTEC	Não
<b>Fornecida em</b> / Supplied in / Fournie avec / Se suministrada en	<b>Caixa plástica</b> / Kitbox / Boite plastique / Kitbox
<b>Código</b> Code / Code / Código	001106100026

<b>Velocidade (rpm)</b> / Speed (rpm) / Vitesse (rpm) / Velocidad (rpm)	450
<b>Energia de impacto (EPTA)(J)</b> / Blow energy (EPTA)(J) / Force de frappe (EPTA)(J) / Energía del impacto (EPTA)(J)	7.5
<b>Impactos (ipm)</b> / Impact (ipm) / Impact (ipm) / Impactos (ipm)	3000
<b>Capacidade de furação betão - brocas (mm)</b> / Max. drilling concrete (mm) / Capacité de perçage de béton - foret (mm) / Máx. capacidad de taladrado en hormigón (mm)	40
<b>Capacidade de furação betão - brocas tunel (mm)</b> / Max. drilling tunnel (mm) / Capacité de perçage de béton - turbo trépan (mm) / Máx. capacidad de taladrado con broca tunel (mm)	65
<b>Capacidade de furação betão - coroas (mm)</b> / Max. drilling core bit (mm) / Capacité de perçage de béton - trépan (mm) / Máx. capacidad de taladrado con corona (mm)	105
<b>Encabadouro</b> / Tool reception / Emmanchement / Eje portabrocas	SDS-Max
<b>Nível de vibração em furação (m/s<sup>2</sup>)</b> / Vibration drilling (m/s <sup>2</sup> ) / Niveau de vibration en perçage (m/s <sup>2</sup> ) / Vibración de taladrado (m/s <sup>2</sup> )	16.8
<b>Nível de vibração em cinzelagem (m/s<sup>2</sup>)</b> / Vibration chiseling (m/s <sup>2</sup> ) / Niveau de vibration en burinage (m/s <sup>2</sup> ) / Vibración de cincelado (m/s <sup>2</sup> )	16.7
<b>Fornecida em</b> / Supplied in / Fournie avec / Se suministrada en	<b>Caixa plástica</b> / Kitbox / Boite plastique / Kitbox
<b>Código</b> Code / Code / Código	001106000540

## Martelos Demolidores

Breaking Hammer / Marteaux de Démolition / Martillo Demolador

KANGO 500 ST

**Martelo Demolidor 5 Kg**  
/ 5 Kg Class Breaking Hammer / Marteau de Démolition 5 Kg  
/ Martillo Demolador 5 Kg



**1100W** **5.9Kg** **7.5**

KANGO 900 S

**Martelo Demolidor 10 Kg**  
/ 10 kg Class Breaking Hammer / Marteau de Démolition 10 Kg  
/ Martillo Demolador 10 Kg



**1600W** **11.0Kg** **20**

<b>Energia de impacto (EPTA)(J)</b> / Blow energy (EPTA)(J) / Force de frappe (EPTA)(J) / Energía del impacto (EPTA)(J)	7.5
<b>Impactos (ipm)</b> / Impact (ipm) / Impact (ipm) / Impactos (ipm)	3000
<b>Encabadouro</b> / Tool reception / Emmanchement / Eje portabrocas	SDS-Max
<b>Nível de vibração em cinzelagem (m/s<sup>2</sup>)</b> / Vibration chiseling (m/s <sup>2</sup> ) / Niveau de vibration en burinage (m/s <sup>2</sup> ) / Vibración de cincelado (m/s <sup>2</sup> )	16.7
<b>Fornecida em</b> / Supplied in / Fournie avec / Se suministrada en	<b>Caixa plástica</b> / Kitbox / Boite plastique / Kitbox
<b>Código</b> Code / Code / Código	001106000501

<b>Energia de impacto (EPTA)(J)</b> / Blow energy (EPTA)(J) / Force de frappe (EPTA)(J) / Energía del impacto (EPTA)(J)	20
<b>Impactos (ipm)</b> / Impact (ipm) / Impact (ipm) / Impactos (ipm)	975 - 1950
<b>Encabadouro</b> / Tool reception / Emmanchement / Eje portabrocas	SDS-Max
<b>Nível de vibração em cinzelagem (m/s<sup>2</sup>)</b> / Vibration chiseling (m/s <sup>2</sup> ) / Niveau de vibration en burinage (m/s <sup>2</sup> ) / Vibración de cincelado (m/s <sup>2</sup> )	11
<b>Fornecida em</b> / Supplied in / Fournie avec / Se suministrada en	<b>Caixa plástica</b> / Kitbox / Boite plastique / Kitbox
<b>Código</b> Code / Code / Código	001106000900

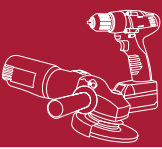

# FERRAMENTA ELÉTRICA

Power Tools / Outilsage Électrique / Herramienta Eléctrica

## Máquinas Elétricas

Electric Machines / Machines Électriques / Máquinas Eléctricas

### DWSE 4000 Q

Aparafusadora Elétrica / Drywall Screwdriver / Visseuse Électrique / Atornillador para cartónyeso



<b>Velocidade em vazio (rpm)</b> / No load speed gear (rpm) / Vitesse à vide (rpm) / Velocidad en vacío (rpm)	0 - 4000
<b>Capacidade de colocação de parafusos em madeira (mm)</b> / The ability to put screws in wood (mm) / La capacité de placer des vis à bois (mm) / La habilidad para poner los tornillos en la madera (mm)	4.8
<b>Encabadouro</b> / Tool reception / Emmanchement / Eje portabrocas	¼" Hex
<b>Fornecida em</b> / Supplied in / Fournie avec / Se suministrada en	<b>Caixa cartão</b> / Card Box / Boite de carte / Caja de cartón
<b>Código</b> Code / Code / Código	001103004000



### PD-705

Berbequim Elétrico / 705 W Percussion Drill / Perceuse à Percussion 705W / Taladro Percutor de 705 W, 1 velocidades

<b>Velocidade em vazio (rpm)</b> / No load speed gear (rpm) / Vitesse à vide (rpm) / Velocidad en vacío (rpm)	0 - 3000
<b>Capacidade de furação pedra (mm)</b> / Max. drilling stone (mm) / Capacité de perçage de pierre (mm) / Máx. capacidad de taladrado en piedra (mm)	15
<b>Capacidade de furação betão (mm)</b> / Max. drilling concrete (mm) / Capacité de perçage de béton (mm) / Máx. capacidad de taladrado en hormigón (mm)	16
<b>Capacidade de furação metal (mm)</b> / Max. drilling steel (mm) / Capacité de perçage de métal (mm) / Máx. capacidad de taladrado en hierro (mm)	13
<b>Capacidade de furação madeira (mm)</b> / Max. drilling wood (mm) / Capacité de perçage de bois (mm) / Máx. capacidad de taladrado en madera (mm)	30
<b>Bucha (mm)</b> / Anchor (mm) / Cheville (mm) / Anclaje (mm)	13
<b>Fornecida em</b> / Supplied in / Fournie avec / Se suministrada en	<b>Caixa cartão</b> / Card Box / Boite de carte / Caja de cartón
<b>Código</b> Code / Code / Código	001104072705



### HDE 13 RQX

Berbequim Rotativo 950W  
/ 950 W Single Speed Rotary Drill / Perceuse Rotative 950W  
/ Taladro Rotativo 950W



<b>Velocidade (rpm)</b> / Speed (rpm) / Vitesse (rpm) / Velocidad (rpm)	14.700
<b>Oscilações (opm)</b> / Oscillation rate (opm) / Oscillation (opm) / Rango de oscilación (opm)	20.000
<b>Diâmetro órbita (mm)</b> / Oscillation diameter (mm) / Diamètre de l'orbite (mm) / Diámetro de oscilación (mm)	1,6
<b>Dimensão da base (mm)</b> / Sanding pad size (mm) / Dimension de la base (mm) / Tamaño de lija (mm)	115 x 140
<b>Fornecida em</b> / Supplied in / Fournie avec / Se suministrada en	<b>Saco de transporte</b> / Kitbox / Boite plastique / Bolsa de transporte
<b>Código</b> Code / Code / Código	001104095013

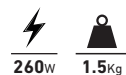

### PD2E 24 R

Berbequim com Percussão 2 velocidades 1020 W  
/ 1020 W 2-Speed Percussion Drill / Perceuse à Percussion 2 vit. 1020 W / Taladro Percutor de 1020 W, 2 velocidades



<b>Velocidade em vazio (Velocidade 1 (rpm))</b> / No load speed gear 1 (rpm) / Vitesse à vide (Vitesse 1 (rpm)) / Velocidad en vacío 1ª Velocidad (rpm)	0 - 1000
<b>Velocidade em vazio (Velocidade 2 (rpm))</b> / No load speed gear 2 (rpm) / Vitesse à vide (Vitesse 2 (rpm)) / Velocidad en vacío 2ª Velocidad (rpm)	0 - 3200
<b>Capacidade de furação pedra (mm)</b> / Drilling stone (mm) / Capacité de perçage de pierre (mm) / Capacidad de taladrado en piedra (mm)	22
<b>Capacidade de furação betão (mm)</b> / Max. drilling concrete (mm) / Capacité de perçage de béton (mm) / Máx. capacidad de taladrado en hormigón (mm)	24
<b>Capacidade de furação metal (mm)</b> / Max. drilling steel (mm) / Capacité de perçage de métal (mm) / Máx. capacidad de taladrado en hierro (mm)	16
<b>Capacidade de furação madeira (mm)</b> / Max. drilling wood (mm) / Capacité de perçage de bois (mm) / Máx. capacidad de taladrado en madera (mm)	40
<b>Bucha (mm)</b> / Anchor (mm) / Cheville (mm) / Anclaje (mm)	13
<b>Fornecida em</b> / Supplied in / Fournie avec / Se suministrada en	<b>Caixa cartão</b> / Card Box / Boite de carte / Caja de cartón
<b>Código</b> Code / Code / Código	001105071524



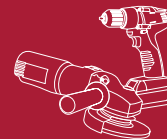

**DGL 30 E**

**Retificadora / Variable Speed Single Hand Die Grinder / Meuluse Droite / Amoladora Recta**

<b>Velocidade em vazio (rpm)</b> / No load speed gear (rpm) / Vitesse à vide (rpm) / Velocidad en vacío (rpm)	10.000 - 30.000
<b>Diâmetro máximo para mós (mm)</b> / Max. grinding wheel diameter (mm) / Diamètre maximum pour meules (mm) / Máx. capacidad de diámetro de disco (mm)	40
<b>Diâmetro máximo para fresas (mm)</b> / Max. grinding pin diameter (mm) / Diamètre maximum pour fraises (mm) / Máx. capacidad con punta de esmerlar (mm)	20
<b>Diâmetro da pinça (mm)</b> / Collet capacity (mm) / Diamètre de la pince (mm) / Capacidad de la pinza de sujeción (mm)	6
<b>Fornecida em</b> / Supplied in / Fournie avec / Se suministrada en	<b>Caixa cartão / Card Box / Boîte de carte / Caja de cartón</b>
<b>Código</b> Code / Code / Código	001112000330

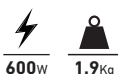

**600W** **1.9Kg**

**SSD 1100 X**

**Serra Sabre 1100 W / 1100 W SAWZALL® / Scie Sabre 1100 W / Sierra de Sable 1100 W**

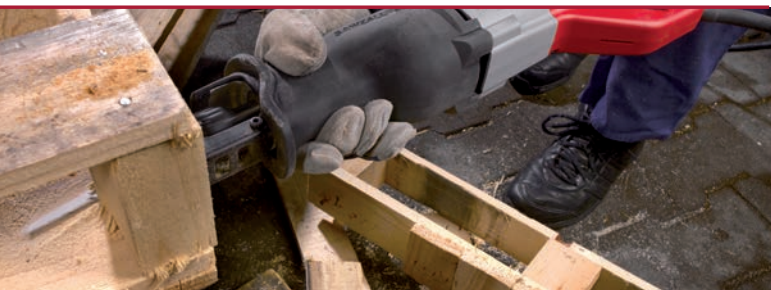

<b>Velocidade em vazio (rpm)</b> / No load speed gear (rpm) / Vitesse à vide (rpm) / Velocidad en vacío (rpm)	0 - 2900
<b>Curso da lâmina (mm)</b> / Stroke length (mm) / Course de la lame (mm) / Longitud de carrera (mm)	28
<b>Fornecida em</b> / Supplied in / Fournie avec / Se suministrada en	<b>Caixa plástica / Kitbox / Boîte plastique / Kitbox</b>
<b>Código</b> Code / Code / Código	001102811000



**1100W**

**3.2Kg**



**JSPE 135 TX**

**Serra Tico Tico / Heavy Duty Top Handle Jigsaw / Scie Sautreuse / Sierra de Calar**

<b>Velocidade em vazio (rpm)</b> / No load speed gear (rpm) / Vitesse à vide (rpm) / Velocidad en vacío (rpm)	800 - 3000
<b>Capacidade máxima de corte madeira (mm)</b> / Max. cutting capacity wood (mm) / Capacité maximale de coupe de bois (mm) / Máx. capacidad en madera (mm)	135
<b>Capacidade máxima de corte aço (mm)</b> / Max. cutting capacity steel (mm) / Capacité maximale de coupe d'acier (mm) / Máx. capacidad en hierro (mm)	10
<b>Capacidade máxima de corte alumínio (mm)</b> / Max. cutting capacity aluminium (mm) / Capacité maximale de coupe d'aluminium (mm) / Máx. capacidad de corte en aluminio (mm)	30
<b>Capacidade ângulo em bisel (°)</b> / Mitre capacity (°) / Capacité de coupe en biais (°) / Capacidad de corte (°)	45
<b>Curso (mm)</b> / Stroke length (mm) / Course (mm) / Longitud de carrera (mm)	26
<b>Fornecida em</b> / Supplied in / Fournie avec / Se suministrada en	<b>Caixa cartão / Card Box / Boîte de carte / Caja de cartón</b>
<b>Código</b> Code / Code / Código	001108750135

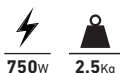

**750W** **2.5Kg**



**SPS 140**

**Lixadora Vibratória / 1/3" Sheet Palm Sander / Ponceuse Vibratoire / Lijadora Orbital de Acabado**



<b>Velocidade (rpm)</b> / Speed (rpm) / Vitesse (rpm) / Velocidad (rpm)	14.700
<b>Oscilações (opm)</b> / Oscillation rate (opm) (mm) / Oscillation (opm) / Rango de oscilación (opm)	20.000
<b>Diâmetro órbita (mm)</b> / Oscillation diameter (mm) / Diamètre de l'orbite (mm) / Diámetro de oscilación (mm)	1,6
<b>Dimensão da base (mm)</b> / Sanding pad size (mm) / Dimension de la base (mm) / Tamaño de lija (mm)	115 x 140
<b>Fornecida em</b> / Supplied in / Fournie avec / Se suministrada en	<b>Saco de transporte / Kitbox / Boîte plastique / Bolsa de transporte</b>
<b>Código</b> Code / Code / Código	001107020113

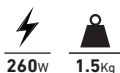

**260W** **1.5Kg**

**ROS 150 E-2**

**Lixadora Orbital / 6" (150 mm) Random Orbit Sander / Ponceuse Excentrique / Lijadora Rotorbital**



<b>Velocidade (rpm)</b> / Speed (rpm) / Vitesse (rpm) / Velocidad (rpm)	4000 - 10.000
<b>Oscilações (opm)</b> / Oscillation rate (opm) (mm) / Oscillation (opm) / Rango de oscilación (opm)	8000 - 11.000
<b>Diâmetro órbita (mm)</b> / Oscillation diameter (mm) / Diamètre de l'orbite (mm) / Diámetro de oscilación (mm)	6,4
<b>Dimensão da base (mm)</b> / Sanding pad size (mm) / Dimension de la base (mm) / Tamaño de lija (mm)	150
<b>Fornecida em</b> / Supplied in / Fournie avec / Se suministrada en	<b>Caixa cartão / Card Box / Boîte de carte / Caja de cartón</b>
<b>Código</b> Code / Code / Código	001107020150

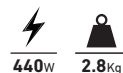

**440W** **2.8Kg**

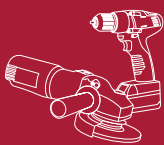

# FERRAMENTA ELÉTRICA

Power Tools / Outillage Électrique / Herramienta Eléctrica

## MCS 66

### Serra Circular Portátil / Dry Cut Metal Circular Saw / Scie Circulaire Portable / Sierra Circular para Corte de Metal sin Chispas y en Frio

Velocidade em vazio (rpm) / No load speed gear (rpm) / Vitesse à vide (rpm) / Velocidad en vacío (rpm)	4000
Diâmetro do disco (mm) / Blade diameter (mm) / Diamètre de la lame (mm) / Diámetro de la hoja (mm)	203
Capacidade de corte a 90° (mm) / Max. cutting depth 90° (mm) / Capacité de coupe à 90° (mm) / Máx. capacidad de corte a 90° (mm)	66
Fornecida em / Supplied in / Fournie avec / Se suministrada en	Caixa plástica / Kitbox / Boite plastique / Kitbox
Código Code / Code / Código	001108650191



## CS 85 SB

### Serra Circular / Circular Saw / Scie Circulaire / Sierra Circular

Velocidade em vazio (rpm) / No load speed gear (rpm) / Vitesse à vide (rpm) / Velocidad en vacío (rpm)	4500
Diâmetro do disco (mm) / Blade diameter (mm) / Diamètre de la lame (mm) / Diámetro de la hoja (mm)	235x30mm
Capacidade de corte a 90° / 45° (mm) / Max. cutting depth 90° / 45° (mm) / Capacité de coupe à 90° / 45° (mm) / Máx. capacidad de corte a 90° / 45° (mm)	85 / 62
Fornecida em / Supplied in / Fournie avec / Se suministrada en	Caixa cartão / Carton box / Boite en carton / Caja en Cartón
Código Code / Code / Código	001190451117



## MS 216 SB

### Serra de Esquadrias 216 mm / 8 1/2" (216 mm) Sliding Mitre Saw / Scie à Onglet Radiale 216 mm / Ingletadora Compacta 216 mm

Velocidade em vazio (rpm) / No load speed gear (rpm) / Vitesse à vide (rpm) / Velocidad en vacío (rpm)	6000
Diâmetro do disco (mm) / Blade diameter (mm) / Diamètre de la lame (mm) / Diámetro de la hoja (mm)	216
Ângulo em bisel à esq (°) / Bevel capacity left (°) / Coupe en biais à gauche (°) / Capacidad de corte a bisel a izquierdas (°)	48
Ângulo em bisel à dir (°) / Bevel capacity right (°) / Coupe en biais à droite (°) / Capacidad de corte a bisel a derechas (°)	- 2
Ângulo em esquadria à esq (°) / Mitre capacity left (°) / Coupe d'onglet à gauche (°) / Capacidad de corte a izquierda (°)	50
Ângulo em esquadria à dir (°) / Mitre capacity right (°) / Coupe d'onglet à droite (°) / Capacidad de corte a derechas (°)	50
Cap. máxima de corte 45° esq / 45° bisel (mm) / Max. cutting capacity 45° mitre / 45° bevel (mm) / Cap. maximale de coupe 45° gauche / 45° biais (mm) / Máx. capacidad de inglete a 45° / bisel 45° (mm)	190 X 48
Cap. máxima de corte 45° esq / 90° bisel (mm) / Max. cutting capacity 45° mitre / 90° bevel (mm) / Cap. maximale de coupe 45° gauche / 90° biais (mm) / Máx. capacidad de inglete a 45° / bisel 90° (mm)	190 X 62
Cap. máxima de corte 90° esq / 45° bisel (mm) / Max. cutting capacity 90° mitre / 45° bevel (mm) / Cap. maximale de coupe 90° gauche / 45° biais (mm) / Máx. capacidad de inglete a 90° / bisel 45° (mm)	270 X 48
Cap. máxima de corte 90° esq / 90° bisel (mm) / Max. cutting capacity 90° mitre / 90° bevel (mm) / Cap. maximale de coupe 90° gauche / 90° biais (mm) / Máx. capacidad de inglete a 90° / bisel 90° (mm)	270 X 60
Furo do disco (mm) / Bore size (mm) / Trou du disque (mm) / Diámetro de perforación (mm)	30
Fornecida em / Supplied in / Fournie avec / Se suministrada en	Caixa cartão / Card Box / Boite de carte / Caja de cartón
Código Code / Code / Código	001128000216



## MSL 1000

### Bancada Universal para Serra de Esquadrias

/ Universal Mitre Saw Stand / Établi pour Scie à Onglet / Banco para Ingletadora Universal

Altura (mm) / Height (mm) / Hauteur (mm) / Tamaño (mm)	850
Base (mm) / Base size (mm) / Base (mm) / Tamaño de base (mm)	1065
Extensível até (mm) / Extendable up to (mm) / Extensible jusqu'à (mm) / Extensible hasta (mm)	2125
Dimensão após dobrada (mm) / Collapsed size (mm) / Dimension après pliage (mm) / Capacidad máxima (mm)	1065
Peso máximo suportado (kg) / Bearing force (kg) / Poids maximum supporté (kg) / Fuerza de engranajes (kg)	180
Fornecida em / Supplied in / Fournie avec / Se suministrada en	Caixa cartão / Card Box / Boite de carte / Caja de cartón
Código Code / Code / Código	001128001000





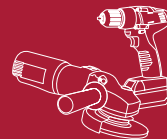

**AG 800-115E/125E**

**Rebarbadora de 800 W / 800 W Angle Grinder**  
/ Meuleuse de 800 W / Amoladora Angular de 800 W



**800W** **1.8Kg**

**AG 10-115EK/125EK**

**Rebarbadora de 1000 W / 1000 W Angle Grinder**  
/ Meuleuse de 1000 W / Amoladora Angular de 1000 W



**1000W** **2.1Kg**

AG 800	115 E	125 E
<b>Velocidade em vazio (rpm)</b> / No load speed gear (rpm) / Vitesse à vide (rpm) / Velocidad en vacío (rpm)	11,000	11,000
<b>Diâmetro do disco (mm)</b> / Disc diameter (mm) / Diamètre du disque (mm) / Diámetro del disco (mm)	115	125
<b>Capacidade de corte (mm)</b> / Max. cutting depth (mm) / Max. capacidad de profundidad de corte (mm) / Max. capacidad de profundidad de corte (mm)	28	33
<b>Rosca do veio</b> / Spindle size / Filetage de l'Arbre / Tamaño del eje	M 14	M 14
<b>Flange FIXTEC</b> / FIXTEC flange nut / Brides FIXTEC / Tuercas FIXTEC	Não / No / Non / No	Não / No / Non / No
<b>Cabo elétrico (m)</b> / Electrical Cable (m) / Câble Eletrique / Cabo Elétrico (m)	4	4
<b>Fornecida em</b> / Supplied in / Fournie avec / Se suministrada en	<b>Caixa cartão</b> / Card Box / Boîte de carte	<b>Caixa cartão</b> / Card Box / Boîte de carte
<b>Código</b> Code / Code / Código	001190451210	001190451211

AG 10	115 EK	125 EK
<b>Velocidade em vazio (rpm)</b> / No load speed gear (rpm) / Vitesse à vide (rpm) / Velocidad en vacío (rpm)	11,000	11,000
<b>Diâmetro do disco (mm)</b> / Disc diameter (mm) / Diamètre du disque (mm) / Diámetro del disco (mm)	115	125
<b>Capacidade de corte (mm)</b> / Max. cutting depth (mm) / Max. capacidad de profundidad de corte (mm) / Max. capacidad de profundidad de corte (mm)	28	33
<b>Rosca do veio</b> / Spindle size / Filetage de l'Arbre / Tamaño del eje	M 14	M 14
<b>Flange FIXTEC</b> / FIXTEC flange nut / Brides FIXTEC / Tuercas FIXTEC	Não / No / Non / No	Não / No / Non / No
<b>Cabo elétrico (m)</b> / Electrical Cable (m) / Câble Eletrique / Cabo Elétrico (m)	4	4
<b>Fornecida em</b> / Supplied in / Fournie avec / Se suministrada en	<b>Caixa cartão</b> / Card Box / Boîte de carte	<b>Caixa cartão</b> / Card Box / Boîte de carte
<b>Código</b> Code / Code / Código	001190451219	001190451220



**AGV 12 - 125X**

**Rebarbadora 1200 W / 1200 W Angle Grinder**  
/ Meuleuse de 1200 W / Amoladora Angular de 1200 W

<b>Velocidade em vazio (rpm)</b> / No load speed gear (rpm) / Vitesse à vide (rpm) / Velocidad en vacío (rpm)	11,000
<b>Diâmetro do disco (mm)</b> / Disc diameter (mm) / Diamètre du disque (mm) / Diámetro del disco (mm)	125
<b>Capacidade de corte (mm)</b> / Max. cutting depth (mm) / Max. capacidad de profundidad de corte (mm) / Max. capacidad de profundidad de corte (mm)	33
<b>Rosca do veio</b> / Spindle size / Filetage de l'Arbre / Tamaño del eje	M 14
<b>Flange FIXTEC</b> / FIXTEC flange nut / Brides FIXTEC / Tuercas FIXTEC	Não / No / Non / No
<b>Fornecida em</b> / Supplied in / Fournie avec / Se suministrada en	<b>Caixa cartão</b> / Card Box / Boîte de carte
<b>Código</b> Code / Code / Código	001190428085



**1200W** **2.4Kg**



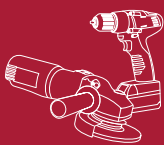

# FERRAMENTA ELÉTRICA

Power Tools / Outillage Électrique / Herramienta Eléctrica

## AGV 15-125XE

Rebarbadora 1550 W / 1550 W Angle Grinder  
/ Meuleuse de 1550 W / Amoladora Angular de 1550 W



**1550W** **2.6Kg**

<b>Velocidade em vazio (rpm)</b> / No load speed gear (rpm) / Vitesse à vide (rpm) / Velocidad en vacío (rpm)	11,000
<b>Diâmetro do disco (mm)</b> / Disc diameter (mm) / Diamètre du disque (mm) / Diámetro del disco (mm)	125
<b>Capacidade de corte (mm)</b> / Max. cutting depth (mm) / Máx. capacidad de profundidad de corte (mm) / Máx. capacidad de profundidad de corte (mm)	33
<b>Rosca do veio</b> / Spindle size / Filetage de l'Arbre / Tamaño del eje	M 14
<b>Flange FIXTEC</b> / FIXTEC flange nut / Brides FIXTEC / Tuercas FIXTEC	Não / No / Non / No
<b>Velocidade variável</b> / Variable speed / Vitesse variable / Velocidad variable	Não / No / Non / No
<b>Fornecida em</b> / Supplied in / Fournie avec / Se suministrada en	<b>Caixa cartão</b> / Card Box / Boite de carte / Caja de cartón
<b>Código</b> Code / Code / Código	001190428127

## AGV 17-125 INOX

Rebarbadora 1750 W / 1750 W Angle Grinder  
/ Meuleuse de 1750 W / Amoladora Angular de 1750 W



**1750W** **2.8Kg**

<b>Velocidade em vazio (rpm)</b> / No load speed gear (rpm) / Vitesse à vide (rpm) / Velocidad en vacío (rpm)	2000 - 7600
<b>Diâmetro do disco (mm)</b> / Disc diameter (mm) / Diamètre du disque (mm) / Diámetro del disco (mm)	125
<b>Capacidade de corte (mm)</b> / Max. cutting depth (mm) / Máx. capacidad de profundidad de corte (mm) / Máx. capacidad de profundidad de corte (mm)	33
<b>Rosca do veio</b> / Spindle size / Filetage de l'Arbre / Tamaño del eje	M 14
<b>Flange FIXTEC</b> / FIXTEC flange nut / Brides FIXTEC / Tuercas FIXTEC	Sim / Yes / Oui / Si
<b>Velocidade variável</b> / Variable speed / Vitesse variable / Velocidad variable	Sim / Yes / Oui / Si
<b>Fornecida em</b> / Supplied in / Fournie avec / Se suministrada en	<b>Caixa cartão</b> / Card Box / Boite de carte / Caja de cartón
<b>Código</b> Code / Code / Código	001190449870



## AGV 22-230

Rebarbadora 2200 W / 2200 W Angle Grinder  
/ Meuleuse de 2200 W / Amoladora Angular de 2200 W



**2200W** **5.4Kg**

<b>Velocidade em vazio (rpm)</b> / No load speed gear (rpm) / Vitesse à vide (rpm) / Velocidad en vacío (rpm)	6600
<b>Diâmetro do disco (mm)</b> / Disc diameter (mm) / Diamètre du disque (mm) / Diámetro del disco (mm)	230
<b>Capacidade de corte (mm)</b> / Max. cutting depth (mm) / Máx. capacidad de profundidad de corte (mm) / Máx. capacidad de profundidad de corte (mm)	68
<b>Rosca do veio</b> / Spindle size / Filetage de l'Arbre / Tamaño del eje	M 14
<b>Flange FIXTEC</b> / FIXTEC flange nut / Brides FIXTEC / Tuercas FIXTEC	Não / No / Non / No
<b>Interruptor de Segurança</b> / Deadman switch / Interrupteur de sécurité / Interruptor de hombre muerto	Não / No / Non / No
<b>Sistema eletrônico de segurança</b> / Line lock out function / Système électronique de sécurité / Relé de baja tensión	Sim / Yes / Oui / Si
<b>Sistema automático de equilíbrio do disco</b> / Autobalancer system / Système d'autobalancier du disque / Sistema auto-balancer	Não / No / Non / No
<b>Sistema anti-vibração</b> / AVS Anti-Vibration System / Système anti-vibration / Empuñadura lateral AVS	Sim / Yes / Oui / Si
<b>Punho posterior rotativo</b> / Rotatable main handle / Poignée postérieure rotative / Empuñadura rotativa	Não / No / Non / No
<b>Fornecida em</b> / Supplied in / Fournie avec / Se suministrada en	<b>Caixa cartão</b> / Card Box / Boite de carte / Caja de cartón
<b>Código</b> Code / Code / Código	001101220230



## AS 30 LAC

Aspirador de 30 Litros / 30 L - Class Dust Extractor - Easy Clean Filter Cleaning / Aspirateur de 30 Litres / Aspirador de 30 Litros Clase L con Fácil Limpieza de Filtro

<b>Fluxo de ar (litros/min)</b> / Air volume (l/min) / Débit d'air (litres/min) / Volumen de aire (l/min)	4500
<b>Capacidade de sucção (mbar)</b> / Max. vacuum (mbar) / Capacité de succion (mbar) / Máx. potencia de aspiración (mbar)	250
<b>Capacidade do depósito (litros)</b> / Capacity (l) / Capacité du réservoir (litres) / Capacidad (l)	30
<b>Diâmetro do tubo flexível (mm)</b> / Hose diameter (mm) / Diamètre du tube flexible (mm) / Diámetro de la manguera (mm)	36
<b>Comprimento do tubo flexível (m)</b> / Hose length (mm) / Longueur du tube flexible (mm) / Largo de la manguera (mm)	4
<b>Comprimento do cabo elétrico (m)</b> / Electric cable length (mm) / Longueur du câble électrique (mm) / Largo del cable eléctrico (mm)	7,5
<b>Fornecida em</b> / Supplied in / Fournie avec / Se suministrada en	<b>Caixa cartão</b> / Card Box / Boite de carte / Caja de cartón
<b>Código</b> Code / Code / Código	001190459411



**1200W** **14.5Kg**



**NOVO**  
NEW / NOUVEAU / NUEVO

# TICK™

## RASTREIE O QUE QUISER. RESISTE A QUALQUER CONDIÇÃO

/ Tracks anything. Survives everything  
/ Tracez ce que vous voulez. Résiste à toute condition  
/ Rastrea lo que quieras. Resiste cualquier condición



### **SEGUIMENTO DE EQUIPAMENTOS COM TICK™**

/ Follow-up equipment with TICK™  
/ Suivi des équipements avec TICK™  
/ Seguimiento de cualquier equipamiento con TICK™

O seguimento integrado da ferramenta permite-lhe ter uma visão sobre os seus dispositivos ONE-KEY™ quando não os tenha consigo. A aplicação ONEKEY™ gravará automaticamente a última localização da sua ferramenta quando esta se encontrar a 30m de qualquer dispositivo ONE-KEY™, o que lhe permite identificar com rapidez as ferramentas perdidas e aumentar a responsabilidade da sua equipa.

/The integrated tracking of the tool allows you to monitor your ONE-KEY™ devices when you do not have them with you. The ONEKEY™ application will automatically save the last location of your tool when it is within 30 m of any ONE-KEY™ device, allowing you to quickly identify lost tools and increase your team's responsibility.

/ Le suivi intégré de l'outil vous permet d'avoir une vision de vos dispositifs ONE-KEY™ lorsque vous ne les avez pas. L'application ONEKEY™ enregistrera automatiquement le dernier emplacement de votre outil lorsqu'il se trouve à moins de 30 mètres d'un dispositif ONE-KEY™, ce qui vous permet d'identifier rapidement les outils perdus et d'augmenter la responsabilité de votre équipe.

/ El seguimiento integrado de la herramienta permite la visión de sus dispositivos ONE-KEY™ a distancia. La aplicación ONEKEY™ grabará automáticamente la última localización de su herramienta cuando esta se encuentre a 30m de cualquier otro dispositivo ONE-KEY™ y le permite identificar con rapidez las herramientas perdidas y la responsabilidad de su equipo.

### **PEQUENO, ADAPTÁVEL E FÁCIL DE FIXAR**

/ SMALL, ADAPTABLE AND EASY TO FIX / PETIT, ADAPTABLE ET FACILE À FIXER / PEQUEÑO, ADAPTABLE Y FÁCIL DE FIJAR

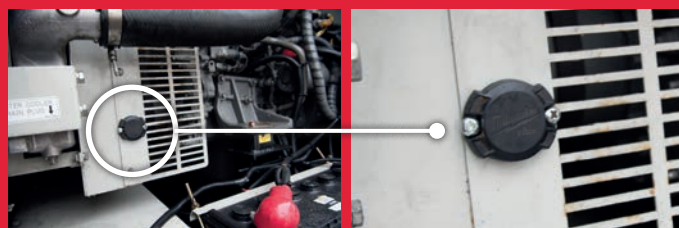

#### **RESISTENTE AO CLIMA**

Weather resistant  
/ Résistant aux conditions climatiques  
/ Resistente al clima



#### **RESISTENTE À ÁGUA E À POEIRA**

Water and dust resistant  
/ Résistant à l'eau et à la poussière  
/ Resistente al agua y al polvo



#### **RESISTENTE A IMPACTOS**

Impact resistant  
/ Résistant aux impacts  
/ Resistente a impactos



### **FIXE-O ONDE QUISER. FÁCIL DE OCULTAR**

/ ATTACHES ANYWHERE. EASY TO HIDE / FIXEZ-LE OÙ VOUS VOULEZ. FACILE À CACHER / FÍJELO DONDE QUIERA. FÁCIL DE OCULTAR

#### **COLADO**

/ GLUE / COLLÉ / PEGADO



#### **REBITADO**

/ RIVET / RIVETÉ / REMACHADO



#### **APARAFUSADO**

/ SCREW / VISSÉ / ATORNILLADO



#### **FITADO**

/ ZIP TIE / RUBANÉ / CON BRIDA DE PLÁSTICO



#### **CÓDIGO**

/ CODE  
/ CODE  
/ CÓDIGO

#### **DESCRIÇÃO**

DESCRIPTION  
/ DESCRIPTION  
/ DESCRIPCIÓN

#### **VE JA O VÍDEO**

/ WATCH THE VIDEO  
/ REGARDER LA VÍDEO  
/ VEA EL VIDEO

#### **LOCALIZADOR TICK ONE-KEY MILWAUKEE**

/ TOOL AND EQUIPMENT  
TRACKER TICK  
/ TICK MILWAUKEE® - PUCE  
BLUETOOTH  
/ MÓDULO DE RASTREO MILWAUKEE®  
TICK - BLUETOOTH®

001190459349



**ONE-KEY**  
UNLOCKING THE DIGITAL JOBSITE.

**COLOCAR. RASTREAR. ADMINISTRAR**  
ATTACH. TRACK. MANAGE. / PLACER. TRACER. ADMINISTRAR  
/ COLOCAR. RASTREAR Y ADMINISTRAR



**FAÇA O DOWNLOAD GRATUITO DA APLICAÇÃO! / DOWNLOAD THE FREE APP NOW / TÉLÉCHARGEMENT GRATUIT DE L'APPLICATION! / BAJE DE FORMA GRATUITA LA APLICACIÓN!**

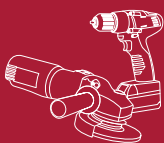

# FERRAMENTA ELÉTRICA

Power Tools / Outillage Électrique / Herramienta Eléctrica

## Rebarbadoras RASO

Angle Grinder RASO / Meuleuse RASO / Amoladora Angular RASO

125

Rebarbadora / Angle Grinder / Meuleuse / Amoladora Angular

<b>Velocidade em vazio (rpm)</b> / No load speed gear (rpm) / Vitesse à vide (rpm) / Velocidad en vacío (rpm)	11000
<b>Diâmetro do disco (mm)</b> / Disc diameter (mm) / Diamètre du disque (mm) / Diámetro del disco (mm)	125
<b>Capacidade de corte (mm)</b> / Max. cutting depth (mm) / Máx. capacidad de profundidad de corte (mm) / Máx. capacidad de profundidad de corte (mm)	28
<b>Rosca do veio</b> / Spindle size / Filetage de l'Arbre / Tamaño del eje	M 14
<b>Fornecida em</b> / Supplied in / Fournie avec / Se suministrada en	Caixa cartão / Card Box / Boite de carte / Caja de cartón
<b>Código</b> Code / Code / Código	009701002157

**RASO**  
INNOVATION & TECHNOLOGY



**750W** **2.2Kg**



230

Rebarbadora / Angle Grinder / Meuleuse / Amoladora Angular

<b>Velocidade em vazio (rpm)</b> / No load speed gear (rpm) / Vitesse à vide (rpm) / Velocidad en vacío (rpm)	6500
<b>Diâmetro do disco (mm)</b> / Disc diameter (mm) / Diamètre du disque (mm) / Diámetro del disco (mm)	230
<b>Capacidade de corte (mm)</b> / Max. cutting depth (mm) / Máx. capacidad de profundidad de corte (mm) / Máx. capacidad de profundidad de corte (mm)	68
<b>Rosca do veio</b> / Spindle size / Filetage de l'Arbre / Tamaño del eje	M 14
<b>Fornecida em</b> / Supplied in / Fournie avec / Se suministrada en	Caixa cartão / Card Box / Boite de carte / Caja de cartón
<b>Código</b> Code / Code / Código	009701002160

**RASO**  
INNOVATION & TECHNOLOGY



**2300W** **6.5Kg**



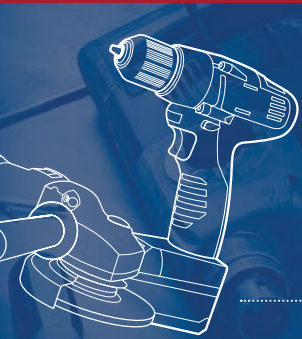

# SERVIÇO ASSISTÊNCIA TÉCNICA

## TECHNICAL ASSISTENCE SERVICE

### SERVICE D' ASSISTANCE TECHNIQUE

#### SERVICIO DE ASISTENCIA TÉCNICA



800 20 29 12



sat@pecol.pt



O Serviço de Assistência Técnica (SAT) Pecol, garante uma assistência e reparação por uma equipa de técnicos especializados e sempre atualizados quanto aos procedimentos, problemas e soluções mais adequadas na resolução de qualquer avaria ou defeitos do seu equipamento elétrico. A Pecol disponibiliza a todos os seus clientes que adquirem ferramentas elétricas um serviço de recolha em qualquer ponto de Portugal Continental, reparamos esses equipamentos e devolvemos em segurança nas instalações da sede da sua empresa. Este serviço é totalmente gratuito para equipamentos que subscrevam as condições e que estejam dentro do período de garantia.

The Pecol Technical Assistance Service (SAT) guarantees the repair by a team of skilled technicians and always updated about the procedures, problems and best solutions in resolving any malfunction or failure of your electrical equipment. Pecol provides to all customers who purchase power tools a pick-up service at any point in mainland Portugal. The equipment is repaired and returned safely on your company headquarters. This service is completely free of charge for any equipment within the warranty conditions.

Le Service d'Assistance Technique (SAT) Pecol garantit un service de réparation par une équipe de techniciens qualifiés et toujours à jour sur les procédures, les problèmes et les meilleures solutions pour résoudre tout dysfonctionnement ou une panne de votre équipement électrique. Pecol disponibilise à tous les clients qui achètent des outils électriques un service de ramassage partout au Portugal continental, l'équipement réparé est retourné en toute sécurité sur les lieux de votre siège de la société. Ce service est totalement gratuit pour les équipements et les conditions qui sont dans la période de garantie.

El Servicio de Asistencia Técnica (SAT) Pecol, garantiza una asistencia y reparación por un equipo de técnicos especializados y siempre actualizados en cuanto a los procedimientos, problemas y soluciones más adecuados en la resolución de cualquier avería o defectos de su equipo eléctrico. Pecol se pone a disposición para todos los clientes que adquieran las herramientas eléctricas para que estas sean recogidas en cualquier punto de Portugal continental, repara el equipo y devuelve en seguridad en las instalaciones de la sede de su empresa. Este servicio es totalmente gratuito para equipos que suscriben las condiciones y que estén dentro del período de garantía

#### TUDO O QUE PRECISAR DE SABER SOBRE INFORMAÇÕES TÉCNICAS. AS SUAS DÚVIDAS SERÃO RESPONDIDAS COM RAPIDEZ E COMPETÊNCIA.

What you need to know about technical information. Individual questions are answered quickly and competently

Tout ce que vous devez savoir sur informations techniques. Nous répondrons rapidement et avec compétence à vos questions

Todo lo que necesita saber acerca de informaciones técnicas. Sus preguntas serán contestadas de forma rápida y competente

#### EQUIPA DE TÉCNICOS ESPECIALIZADOS

TEAM OF SPECIALIZED TECHNIQUES  
/ EQUIPE DE TECHNIQUES SPECIALISES  
/ EQUIPO DE TÉCNICOS ESPECIALIZADOS



#### RECOLHEMOS, REPARAMOS E DEVOLVEMOS O SEU EQUIPAMENTO

WE COLLECT, WE REPAIR AND RETURN YOUR EQUIPMENT  
/ ON COLLECT, REPARONS ET RETOURNONS VOTRE ÉQUIPEMENT  
/ RECOGEMOS, REPARAMOS Y DEVOLVEMOS SU EQUIPO



# CARRINHA DE DEMONSTRAÇÃO\*

## DEMONSTRATION VAN

### VOITURE DE DEMONSTRATION

### FURGONETA DE DEMOSTRACIÓN



\* APENAS DISPONÍVEL PARA PORTUGAL CONTINENTAL.

/ ONLY AVAILABLE IN PORTUGAL MAINLAND / DISPONIBLE SEULEMENT AU PORTUGAL CONTINENTAL / DISPONIBLE PARA PORTUGAL CONTINENTAL

**TEMOS À SUA DISPOSIÇÃO PROFISSIONAIS QUALIFICADOS, DISPONÍVEIS PARA A REALIZAÇÃO DE DEMONSTRAÇÕES PRÁTICAS DA NOSSA GAMA DE MÁQUINAS E APRESENTAÇÃO DE NOVIDADES QUE O PODERÃO AJUDAR NA HORA DE ESCOLHER O PRODUTO MAIS ADEQUADO PARA O SEU NEGÓCIO!!!**

We have at your disposal qualified professionals that are available to perform practical demonstrations of our range of machines and presentation of new products that may help you to choose the most appropriate products for your business!!!

/ On a à votre disposition des professionnels qualifiés, disponibles pour faire des démonstrations de notre gamme de machines et présentation de nouveautés qui vous pourront aider à choisir le meilleur produits, adapté à votre métier!!!

/ Tenemos a su disposición profesionales cualificados, disponibles para la realización de demostraciones prácticas de nuestra gama de máquinas y presentación de novedades que pueden ayudarle a l ahora de escoger el producto más adecuado para su negocio!!!



Milwaukee

Lamello

PECOL®

RASS®  
INNOVATION & TECHNOLOGY

PecWeld



# SOLDADURA

WELDING  
SOUDURE  
SOLDADURA

**PecWeld** PREMIUM  
ELECTRODOS DE SOLDADURA  
WELDING ELECTRODES  
ELECTRODES POUR SOUDER  
by PECOL  
**ELETRODOS DE SOLDADURA**

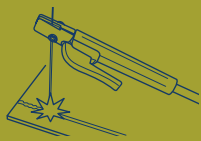

# SOLDADURA

Welding / Soudure / Soldadura

## Elérodos

Electrode / Electrodes / Electrodo

### E 6013

### Elérodos Rutilo / Rutile Coated Electrode / Électrodes Rutile / Electrodo Rutilo



**Menor emissão de fumo**  
/ Lower smoke emission  
/ Réduire les émissions de fumée  
/ Menor emisión de humo

**Excelente soldabilidade**  
/ Excellent welding  
/ Excellente soudabilité  
/ Excelente soldabilidad

**Fácil remoção da escória**  
/ Slag easier to remove  
/ Scories plus faciles à enlever  
/ Fácil eliminación de la escoria

CÓDIGO CODE / CODE / CÓDIGO	DIMENSÕES SIZE / DIMENSIONS / MEDIDA	UNI/Kg	EMBALAGEM QUANTITY / EMBALLAGE / EMBALAJE		
			PACK	UNI	Kg
009114200300	Ø2,00 x 300	104	1	518	6,5
009114250350	Ø2,50 x 350	55	1	335	6,0
009114325350	Ø3,20 x 350	33	1	195	5,8
009114400350	Ø4,00 x 350	21	1	135	6,2



O elétrico rutilo E 6013 é um elétrico de uso geral utilizado para a soldadura de aços de carbono de média dureza e particularmente adequada para a soldadura de chapas de aço de diversas espessuras | Estes elétricos são apropriados para a soldadura em aço estrutural macio, produções de tanques e caldeiras, aços diversos, carrocerias de automóveis, móveis de aço, chapas de metal, chapa fina e pequenas reparações | Apresentam uma resistência à tração até 500 N/mm<sup>2</sup>

E 6013 is a general purpose electrode especially used for the welding of medium carbon steels and particularly suitable for welding of thin plates and sheet steels | It is also useful for welding mild structural steels, pressure and boiler vessels, steels, automotive bodies, steel furnitures, metal plate works, thin plates and small repairs | Having a tensile strength up to 500 N/mm<sup>2</sup>.

L'électrode rutile E 6013 est une électrode d'usage générale utilisée pour le soudage d'acier de carbone de moyenne dureté et particulièrement adéquat pour le soudage de tôle d'acier de diverses épaisseurs | Ces électrodes sont appropriés pour le soudage en acier structural doux, production de réservoirs et chaudières, aciers divers, carrosseries d'automobiles, meubles en acier, tôles de métal, tôles fines et petites | Présentent une résistance à la traction jusqu'à 500 N/mm<sup>2</sup>.

El electrodo rutilo E 6013 es un electrodo de uso general utilizado para la soldadura de aceros de carbono de media dureza y particularmente adecuado para la soldadura de chapas de acero de diversos espesores | Estos electrodos son apropiados para la soldadura en acero estructural suave, producciones de tanques y calderas, aceros diversos, carrocerias de automóviles, muebles de acero, placas de metal, placa fina y pequeñas reparaciones | Presentan una resistencia a la tracción hasta 500 N/mm<sup>2</sup>.



**Posições de soldadura / Welding Positions / Positions de soudage / Posiciones de soldadura**

**Todas as posições / All positions / Toutes les positions / Todas las posiciones**

**Certificados / Certifications / Certificats / Certificados**

**AWS/ASME SFA-5.1 E6013 | EN 499 | DIN 1913 | EN ISO 2560-A**

### E 7018

### Elérodos Básico / Basic Coated Electrode / Électrodes Basiques / Electrodo Básico



**Menor emissão de fumo**  
/ Lower smoke emission  
/ Réduire les émissions de fumée  
/ Menor emisión de humo

**Excelente soldabilidade**  
/ Excellent welding  
/ Excellente soudabilité  
/ Excelente soldabilidad

**Fácil remoção da escória**  
/ Slag easier to remove  
/ Scories plus faciles à enlever  
/ Fácil eliminación de la escoria

CÓDIGO CODE / CODE / CÓDIGO	DIMENSÕES SIZE / DIMENSIONS / MEDIDA	UNI/Kg	EMBALAGEM QUANTITY / EMBALLAGE / EMBALAJE		
			PACK	UNI	Kg
009111250350	Ø2,50 x 350	44	1	233	5,2
009111320350	Ø3,20 x 350	28	1	150	5,2
009111400350	Ø4,00 x 350	19	1	111	5,6



O elétrico básico E 7018 é especialmente utilizado para a soldadura de aço carbono de baixa e média dureza | São apropriados para a soldadura em estruturas metálicas sujeitas a movimentações, construção naval, produções de tanques e caldeiras, fabricações de máquinas, construções de pontes, carrocerias de automóveis, móveis de aço, chapas de metal, ...

E 7018 is a general purpose basic electrode especially used for the welding of low and medium carbon structural steels, ranging between St 33 and St 52.3 | Suitable for welding on dynamically loaded structures, shipbuilding, tank and boiler productions, machinery fabrications, bridge constructions, automotive bodies, steel furnitures, metal plate works ...

L'électrode basique E 7018 est spécialement utilisée pour le soudage d'acier carbone de basse et moyenne dureté | Elles sont appropriées pour le soudage de structures métalliques soumises à des mouvements, construction navale, production de réservoirs et chaudières, fabrications de machines, constructions de ponts, carrosseries d'automobiles, meubles en acier, tôles de métal, ...

El electrodo básico E 7018 es especialmente utilizado en la soldadura de acero carbono de baja y media dureza | Son apropiados para la soldadura en estructuras metálicas sujetas a movilizaciones, construcción naval, producciones de estanques y calderas, fabricaciones de máquinas, construcciones de puentes, carrocerias de automóviles, muebles de acero, chapas de metal, ...



**Posições de soldadura / Welding Positions / Positions de soudage / Posiciones de soldadura**

**Todas as posições excepto vertical-baixo / All positions except vertical-down / Toutes les positions à l'exception de vertical-bas / Todas las posiciones excepto vertical descendiente**

**Certificados / Certifications / Certificats / Certificados**

**AWS/ASME SFA-5.1 E7018 | EN 499 | DIN 1913 | EN ISO 2560-A**

### E 308L-16

### Elérodos de solda para Aço Inox / Welding Stainless Steels Stick Electrodes / Électrodes de soudure pour Acier Inox / Electrodo de soldadura Acero Inox



CÓDIGO CODE / CODE / CÓDIGO	DIMENSÕES SIZE / DIMENSIONS / MEDIDA	UNI/Kg	EMBALAGEM QUANTITY / EMBALLAGE / EMBALAJE		
			PACK	UNI	Kg
009112200300	Ø2,00 x 300	90	5	900	10
009112250300	Ø2,50 x 350	44	5	440	10
009112325350	Ø3,20 x 350	29	5	290	10



Utilizável em soldadura de tanques de aço inox, válvulas, condutas e revestimentos nas indústria química ou de transformação alimentar | Para temperaturas até 350°C, não escamando a superfície até temperaturas de 800°C | Utilização possível em corrente AC e em DC | Para utilização em aço inox 302, 304 e 308

Suitable for welding stainless steel tanks, valves, pipes and linings in chemical and food industries | For operating temperatures of up to +350°C, non-scaling up to +800°C | Possible to use equally well both with AC and DC | To be used with type 302, 304 and 308 stainless steel

Utilisable en soudure de réservoirs d'acier inox, valves, conduits et revêtements dans l'industrie chimique ou de transformation alimentaire | Pour des températures jusqu'à 350°C, sans écailler la surface jusqu'à des températures de 800°C | Utilisation possible en courant AC et en DC | Pour utilisation en acier inox 302, 304 et 308

Aplicable en soldadura de estanques de acero inox, válvulas, conductos y revestimientos en la industria química o de transformación alimenticia | Para temperaturas hasta 350°C, no escamando la superficie hasta temperaturas de 800°C | Utilización posible en corriente AC y DC | Para utilización en acero inox 302, 304 y 308



**Posições de soldadura / Welding Positions / Positions de soudage / Posiciones de soldadura**

**Todas as posições excepto vertical-baixo / All positions except vertical-down / Toutes les positions à l'exception de vertical-bas / Todas las posiciones excepto vertical descendiente**

**Certificados / Certifications / Certificats / Certificados**

**AWS/ASME SFA-5.4 E308L | EN 1600 | DIN 8556**



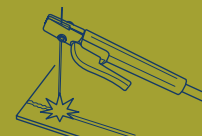

Electrodos de soldadura Acero Inox / Électrodes de soudure pour Acier Inox / Welding Stainless Steels Stick Electrodes / Eléctrodos de solda para Aço Inox

E 316L-16

CÓDIGO CODE / CODE / CÓDIGO	DIMENSÕES SIZE / DIMENSIONS / MEDIDA	UNI/Kg	EMBALAGEM QUANTITY / EMBALLAGE / EMBALAJE		
			PACK	UNI	Kg
009113200300	Ø2,00 x 300	90	5	900	10
009113250300	Ø2,50 x 350	44	5	440	10
009113325350	Ø3,20 x 350	29	5	290	10



**Utilizável em soldadura de tanques de aço inox e condutas na indústria química, têxtil, tintas e produção de papel**

*Especialmente suitable for welding of stainless steel chemical tanks and pipes in chemical, textile, paint and paper industries*

*Utilisable en soudage de réservoirs d'acier inox et conduits dans l'industrie chimique, textile, peintures et production de papier*

*Aplicable en soldadura de estanques de acero inox y conductos en la industria química, textil, pinturas y producción de papel*



**Posições de soldadura / Welding Positions / Positions de soudage / Posiciones de soldadura**

**Todas as posições excepto vertical-baixo / All positions except vertical-down / Toutes les position à l'exception de vertical-bas / Todas las posiciones excepto vertical descendiente**

**Certificados / Certifications / Certificats / Certificados**

**AWS/ASME SFA-5.4 E316L | EN 1600 | DIN 8556**



**Varetas TIG**

TIG Rods / Baguettes TIG / Varillas TIG

**Varetas TIG para soldadura em Aço Inox**

Varillas TIG para soldadura en Acero Inox / Baguettes TIG pour soudure en Acier Inox / TIG Rods for Stainless Steel TIG Welding /

308 L

CÓDIGO CODE / CODE / CÓDIGO	DIMENSÕES SIZE / DIMENSIONS / MEDIDA	EMBALAGEM QUANTITY / EMBALLAGE / EMBALAJE		
		PACK	UNI	Kg
009171100160	Ø1,60 x 1000	4	4	5
009171100200	Ø2,00 x 1000	4	4	5



**A liga 308 é muito usada em indústrias químicas e de transformação alimentar, assim como em tubos e caldeiras | Adaptável para a soldadura de aço inox do tipo 18% Cr – 8% Ni (A2), com um baixo teor de carbono e outros aços do mesmo tipo se a temperatura não exceder os +350°C | Também podem ser utilizadas para soldadura de Aços Cr, exceto em ambientes ricos em gases sulfúricos**

*The 308 alloy is widely used in the chemical and food-processing industries, as well as for pipes, tubes and boilers | Suitable for the joining of stainless steels of the 18% Cr - 8% Ni (A2) type with a low carbon content and Nb-stabilised steels of the same type if the service temperature does not exceed +350°C | It can also be used for welding Cr steels, except in sulphur-rich environments.*

*L'alliage 308 est très utilisé dans l'industrie chimique et de transformation alimentaire, ainsi que dans les tubes et chaudières | Adaptable pour le soudage d'acier inox du type 18% Cr - 8% Ni (A2), avec une basse teneur de carbone et autres acier du même type si la température n'excède pas les +350°C | Peuvent aussi être utilisées pour soudage d'acier Cr, à l'exception d'environnement riches en gaz sulfuriques.*

*La aleación 308 es muy usada en industrias químicas y de transformación alimenticia, así como en tubos y calderas | Adaptable para la soldadura de acero inox del tipo 18% Cr - 8% Ni (A2), con un bajo contenido en carbono y otros aceros del mismo tipo si la temperatura no excede de los +350°C | También pueden ser utilizadas para soldadura de Aceros Cr, excepto en ambientes ricos en gases sulfúricos.*



**Posições de soldadura / Welding Positions / Positions de soudage / Posiciones de soldadura**

**Todas as posições excepto vertical-baixo / All positions except vertical-down / Toutes les position à l'exception de vertical-bas / Todas las posiciones excepto vertical descendiente**

**Certificados / Certifications / Certificats / Certificados**

**AWS/ASME SFA-5.9 ER308 L | EN 12072 | DIN 8556 SG X 2 Cr Ni 19 9**



**Varetas TIG para soldadura em Aço Inox**

Varillas TIG para soldadura en Acero Inox / Baguettes TIG pour soudure en Acier Inox / TIG Rods for Stainless Steel TIG Welding /

316 L

CÓDIGO CODE / CODE / CÓDIGO	DIMENSÕES SIZE / DIMENSIONS / MEDIDA	EMBALAGEM QUANTITY / EMBALLAGE / EMBALAJE		
		PACK	UNI	Kg
009172100160	Ø1,60 x 1000	4	4	5
009172100200	Ø2,00 x 1000	4	4	5



**A liga 316 L é muito usada em indústrias químicas e de transformação alimentar, assim como em construção naval**

*The alloy is widely used in the chemical and food-processing industries, as well as in ship building*

*L'alliage 316 L est très utilisé dans l'industrie chimique et de transformation alimentaire, ainsi que dans la construction navale*

*La aleación 316 L es muy usada en industrias químicas y de transformación alimenticia, así como en construcción naval*



**Posições de soldadura / Welding Positions / Positions de soudage / Posiciones de soldadura**

**Todas as posições excepto vertical-baixo / All positions except vertical-down / Toutes les position à l'exception de vertical-bas / Todas las posiciones excepto vertical descendiente**

**Certificados / Certifications / Certificats / Certificados**

**AWS/ASME SFA-5.9 ER316 L | EN 12072 | DIN 8556 SG X 2 Cr Ni Mo 19 12**



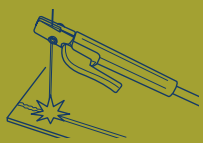

# SOLDADURA

Welding / Soudure / Soldadura

## Fio de Solda

Solid Wire / Fil de Soudure / Hilo de Soldadura

SG2

Fio de Solda SG2 / MIG MAG Solid Wire - SG2 / Fil de Soudure SG2 / Hilo de Soldadura SG2



CÓDIGO CODE / CODE / CÓDIGO	DIMENSÕES SIZE / DIMENSIONS / MEDIDA	BOBINE Kg SPOOL / BOBINE / BOBINE	EMBALAGEM QUANTITY / EMBALLAGE / EMBALAJE
00912008000	Ø0.8	15	1
009120010000	Ø1.0	15	1
009120012000	Ø1.2	15	1



O fio de solda SG2 é utilizado para a soldadura a arco eléctrico de aço estrutural com resistência à tração até 530 N/mm<sup>2</sup> | É particularmente indicado para soldadura de aços galvanizados e pré-pintados, soldagem de aços de baixa liga em tubos, construção de caldeiras e tanques | É também adequado para a soldadura de chapas de metal finas e soldaduras de reparação

It is used for the gas metal arc welding of unalloyed structural steels with a tensile strength up to 530 N/mm<sup>2</sup> | Particularly suitable for welding of galvanized and pre-painted steels, welding low alloy steels in pipe lines, boilers and tank constructions | Suitable also for welding in thin metal plates and repair welds

Le fil de soudure SG2 est utilisé pour le soudage à l'arc électrique d'acier structurel avec une résistance à la traction jusqu'à 530 N/mm<sup>2</sup> | Il est particulièrement indiqué pour le soudage d'aciers galvanisés et pré-peints, soudage d'aciers de bas alliage en tubes, construction de réservoirs et chaudières | Il est aussi adéquat pour le soudage de tôles de métal fin et soudage de réparation

El hilo de soldadura SG2 es utilizado para la soldadura a arco eléctrico de acero estructural con resistencia a la tracción hasta 530 N/mm<sup>2</sup> | Está particularmente indicado para soldadura de aceros galvanizados y prepintados, soldadura de aceros de baja liga en tubos, construcción de calderas y tanques | Es también adecuado para la soldadura de placas de metal finas y soldaduras de reparación



Posições de soldadura / Welding Positions / Positions de soudage / Posiciones de soldadura  
Todas as posições / All positions / Toutes les positions / Todas las posiciones

Certificados / Certifications / Certificats / Certificados

AWS/ASME SFA-5.18 ER70S-6 | EN440 | DIN 8559 | EN ISO 14341-A G3 Si 1



Inox 308 LSi

Fio de Solda Inox 308 LSi para MIG/MAG

Solid Wire for MIG/MAG Welding Stainless Steel 308 LSi / Fil de soudure Inox 308 LSi pour MIG/MAG / Hilo de soldadura Inox 308 LSi para MIG/MAG



CÓDIGO CODE / CODE / CÓDIGO	DIMENSÕES SIZE / DIMENSIONS / MEDIDA	BOBINE Kg SPOOL / BOBINE / BOBINE	EMBALAGEM QUANTITY / EMBALLAGE / EMBALAJE
009123080800	Ø0.8	15	1
009123081000	Ø1.0	15	1



Muito utilizado na indústria química e de transformação alimentar, assim como condutas, tubos e caldeiras

Widely used in the chemical and food processing industries as well as for pipes, tubes and boilers

Très utilisé dans l'industrie chimique et de transformation alimentaire, ainsi que dans les conduits, tuyaux et chaudières

Muy utilizado en la industria química y de transformación alimenticia, así como conductos, tubos y calderas



Posições de soldadura / Welding Positions / Positions de soudage / Posiciones de soldadura  
Todas as posições / All positions / Toutes les positions / Todas las posiciones

Certificados / Certifications / Certificats / Certificados

AWS/ASME SFA-5.9 ER308 LSi | EN 12072 | DIN 8556 SG X 2 Cr Ni 19 9

Inox 316 LSi

Fio de Solda Inox 316 LSi para MIG/MAG

Solid Wire for MIG/MAG Welding Stainless Steel 316 LSi / Fil de soudure Inox 316 LSi pour MIG/MAG / Hilo de soldadura Inox 316 LSi para MIG/MAG



CÓDIGO CODE / CODE / CÓDIGO	DIMENSÕES SIZE / DIMENSIONS / MEDIDA	BOBINE Kg SPOOL / BOBINE / BOBINE	EMBALAGEM QUANTITY / EMBALLAGE / EMBALAJE
009123160800	Ø0.8	15	1
009123161000	Ø1.0	15	1



Muito utilizado na indústria química e de transformação alimentar, assim como construção e reparação naval

Widely used in the chemical and food industries as well as ship repairs and ship buildings

Très utilisé dans l'industrie chimique et de transformation alimentaire, ainsi que dans la construction et réparation navale

Muy utilizado en la industria química y de transformación alimenticia, así como construcción y reparación naval



Posições de soldadura / Welding Positions / Positions de soudage / Posiciones de soldadura  
Todas as posições / All positions / Toutes les positions / Todas las posiciones

Certificados / Certifications / Certificats / Certificados

AWS/ASME SFA-5.9 ER16 LSi | EN 12072 | DIN 8556 SG X 2 Cr Ni Mo 19 12

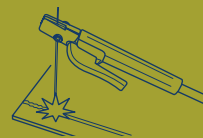

## Inversor

Inverter / Inverseur / Inversor

### Progress 2000

SISTEMA SELECÇÃO  
LOW VOLTAGE  
200 Amp  
60% FATOR DE MARCHA EN 60974



**Inversor portátil (6 kg) | Intensidade de corrente: 200 Amp | Fator de marcha: 60% (EN 60974) | Preparado para eletrodos até 6 mm | Sistema inovador: "Hot Start", "Arc Force" e "Anti Stick" | Pode funcionar com geradores 6 Kva | Cabos incluídos**

Portable inverter (6 kg) | Powerful machine: 200 Amp | Duty cycle: 60% (EN 60974) | Ready for electrodes up to 6 mm | Hot Start, Arc Force and Anti Stick | Suitable to work with 6 Kva generator | Cables included

Poste de soudure portatif (6 kg) | Puissance: 200 Amp | Facteur de marche 60% (EN60974) | Pour électrodes jusqu'à 6mm | Système innovant: "Hot Start", "Arc Force" et "Anti Stick" | Fonctionne avec générateur 6 Kva | Câbles inclus

Inversor portátil (6 kg) | Intensidad de corriente: 200 Amp | Factor de marcha: 60% (EN 60974) | Preparado para electrodos hasta 6mm | Sistema innovador: "Hot Start", "Arc Force" y "Anti Stick" | Puede funcionar con generadores 6 Kva | Cables incluidos

#### Accessórios incluídos

/ Includes / Accessoires inclus / Accesorios incluidos

**Pinça de massa e Alicete porta eletrodos**  
Pure Copper Ground clamp and Pure Copper Electrode holder / Pince de masse et Pince porte électrodes / Pinza de masa y Alicete porta electrodos



2m  
Ø16mm<sup>2</sup>

2.5m  
Ø16mm<sup>2</sup>

CÓDIGO CODE / CODE / CÓDIGO	EMBALAGEM QUANTITY / EMBALLAGE / EMBALAJE
009131000200	1

### Progress 1700L

170 Amp  
60% FATOR DE MARCHA EN 60974



**Inversor portátil (5 kg) | Intensidade de corrente: 170 Amp | Fator de marcha: 60% (EN 60974) | Preparado para eletrodos até 4 mm | Seletor soldadura MMA ou TIG | Sistema inovador: "Hot Start", "Arc Force" e "Anti Stick" | Pode funcionar com geradores 5 Kva | Cabos incluídos**

Portable inverter (5 kg) | Power: 170 Amp | Duty cycle: 60% (EN 60974) | Ready for electrodes up to 4 mm | Switch selector to change from MMA to TIG welding | Hot Start, Arc Force and Anti Stick | Suitable to work with 5 Kva generator | Cables included

Poste de soudure portatif (5 kg) | Puissance: 170 Amp | Facteur de marche 60% (EN60974) | Pour électrode jusqu'à 4mm | Sélecteur de soudure MMA ou TIG | Système innovant: "Hot Start", "Arc Force" et "Anti Stick" | Fonctionne avec générateur 5 Kva | Câbles inclus

Inversor portátil (5 kg) | Intensidad de corriente: 170 Amp | Factor de marcha: 60% (EN 60974) | Preparado para electrodos hasta 4mm | Selector soldadura MMA o TIG | Sistema innovador: "Hot Start", "Arc Force" y "Anti Stick" | Puede funcionar con generadores 5 Kva | Cables incluidos

#### Accessórios incluídos

/ Includes / Accessoires inclus / Accesorios incluidos

**Pinça de massa e Alicete porta eletrodos**  
Pure Copper Ground clamp and Pure Copper Electrode holder / Pince de masse et Pince porte électrodes / Pinza de masa y Alicete porta electrodos



2m  
Ø10mm<sup>2</sup>

2.5m  
Ø10mm<sup>2</sup>

CÓDIGO CODE / CODE / CÓDIGO	EMBALAGEM QUANTITY / EMBALLAGE / EMBALAJE
009131000170	1

### Progress 1500

150 Amp  
60% FATOR DE MARCHA EN 60974



**Inversor compacto e leve (4 kg) | Intensidade de corrente: 150 Amp | Fator de marcha: 60% (EN 60974) | Preparado para eletrodos até 3,25 mm | Sistema inovador: "Hot Start", "Arc Force" e "Anti Stick" | Pode funcionar com geradores 4,5 Kva | Cabos incluídos**

Compact and light inverter (4 kg) | Power: 150 Amp | Duty cycle: 60% (EN 60974) | Ready for electrodes up to 3,25 mm | Hot Start, Arc Force and Anti Stick | Ideal to work with 4,5 Kva generator | Cables included

Poste de soudure compact et léger (4 kg) | Puissance: 150 Amp | Facteur de marche 60% (EN60974) | Pour électrode jusqu'à 3,25 mm | Hot Start, Arc Force et Anti Stick | Fonctionne avec générateur 4,5 Kva | Câbles inclus

Inversor compacto y leve (4 kg) | Intensidad de corriente: 150 Amp | Factor de marcha: 60% (EN 60974) | Preparado para electrodos hasta 3,25 mm | Sistema innovador: "Hot Start", "Arc Force" y "Anti Stick" | Puede funcionar con generadores 4,5 Kva | Cables incluidos

#### Accessórios incluídos

/ Includes / Accessoires inclus / Accesorios incluidos

**Pinça de massa e Alicete porta eletrodos**  
Pure Copper Ground clamp and Pure Copper Electrode holder / Pince de masse et Pince porte électrodes / Pinza de masa y Alicete porta electrodos



2m

2.5m

CÓDIGO CODE / CODE / CÓDIGO	EMBALAGEM QUANTITY / EMBALLAGE / EMBALAJE
009131000150	1

## PecWeld

### Progress 180

180 Amp  
40% FATOR DE MARCHA EN 60974



**Intensidade de corrente: 180 Amp | Fator de marcha: 40% (EN 60974) | Preparado para eletrodos até 5 mm | Sistema inovador: "Hot Start", "Arc Force" e "Anti Stick" | Pode funcionar com geradores 2 a 4 Kva | Cabos incluídos**

Power: 180 Amp | Duty cycle: 40% (EN 60974) | Ready for electrodes up to 5 mm | Hot Start, Arc Force and Anti Stick | Ideal to work with 2 to 4 Kva generator | Cables included

Puissance: 180 Amp | Facteur de marche 40% (EN60974) | Pour électrode jusqu'à 5 mm | Hot Start, Arc Force et Anti Stick | Fonctionne avec générateur 2 - 4 Kva | Câbles inclus

Intensidad de corriente: 180 Amp | Factor de marcha: 40% (EN 60974) | Preparado para electrodos hasta 5 mm | Sistema innovador: "Hot Start", "Arc Force" y "Anti Stick" | Puede funcionar con generadores 2 - 4 Kva | Cables incluidos

#### Accessórios incluídos

/ Includes / Accessoires inclus / Accesorios incluidos

**Pinça de massa e Alicete porta eletrodos**  
Pure Copper Ground clamp and Pure Copper Electrode holder / Pince de masse et Pince porte électrodes / Pinza de masa y Alicete porta electrodos



1m

1m

CÓDIGO CODE / CODE / CÓDIGO	EMBALAGEM QUANTITY / EMBALLAGE / EMBALAJE
009131000180	1



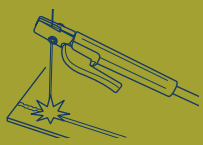

# SOLDADURA

Welding / Soudure / Soldadura

## Inversor

Inverter / Inverseur / Inversor

M40.20

200  
Amp

FACTOR DE MARCA  
40%  
EN 60974



Aparelho compacto para soldadura MMA, TIG, MIG/MAG e fio de solda fluxado | O modo MMA inclui sistema inovador: "Hot Start", "Arc Force" e "Anti Stick" | Inclui tocha MIG/MAG 15K e cabos | Pode funcionar com geradores 6 Kva

Very compact multifunction machine MMA, TIG, MIG/MAG, Flux core welding | MMA mode includes the advantage of Hot Start, Arc Force and Anti Stick | Includes a professional Binzel 15K torch and cables | Ready to operate with 6KVA generator

Poste compact pour soudage MMA, TIG, MIG/MAG et fil de soudure fluxé | Le mode MMA inclut système innovateur: "Hot Start", "Arc Force" e "l'Anti Stick" | Inclut torche MIG/MAG 15K e câbles | Fonctionne avec générateur 6KVA

Aparato compacto para soldadura MMA, TIG, MIG/MAG y hilo de soldadura fluxado | El modo MMA incluye sistema innovador: "Hot Start", "Arc Force" y "Anti Stick" | Incluye antorcha MIG/MAG 15K y cables | Puede funcionar con generadores 6KVA

### Accessórios incluídos

/ Includes / Accessoires inclus / Accesorios incluidos

### Pinça de massa, Alicete porta eletrodos e Tocha MIG/MAG 15 AK

Pure Copper Ground clamp, Pure Copper Electrode holder and Torch Binzel 15 AK / Pince de masse, Pince porte électrodes et Torche MIG/MAG 15 AK / Pinza de masa, Alicete porta electrodos y Antorcha MIG/MAG 15 AK



CÓDIGO  
CODE / CODE  
/ CÓDIGO

EMBALAGEM  
QUANTITY / EMBALLAGE  
/ EMBALAJE

009130004020

1

MIG 250 T

250  
Amp

FACTOR DE MARCA  
60%  
EN 60974



Aparelho para soldadura a fio (MIG/MAG) com arco pulsado | Versátil: Soldadura MMA, TIG e MIG/MAG | Totalmente programável e Visor LCD | Intensidade de corrente: 250 Amp | Fator de marcha: 60% (EN 60974) | Pode funcionar com geradores 8 Kva

Professional inverter machine for MIG/MAG welding with pulse arc | Very versatile: MMA, TIG and MIG/MAG welding | Fully programmed and Large LCD display | Powerful 250 Amp at 60% duty cycle | Ready to operate with 8KVA generator

Poste pour soudage à fil (MIG/MAG) avec arc pulsé | Versatile: Soudure MMA, TIG et MIG/MAG | Totalemt programmable et écran LCD | Puissance: 250 Amp | Facteur de marche 60% (EN60974) | Fonctionne avec générateur 8KVA

Aparato para soldadura a hilo (MIG/MAG) con arco pulsado | Versátil: Soldadura MMA, TIG y MIG/MAG | Totalmente programable y Visor LCD | Intensidad de corriente: 250 Amp | Factor de marcha: 60% (EN60974) | Puede funcionar con generadores 8KVA

### Accessórios incluídos

/ Includes / Accessoires inclus / Accesorios incluidos

### Pinça de massa, Alicete porta eletrodos e Tocha MIG/MAG 25 AK

Pure Copper Ground clamp, Pure Copper Electrode holder and Torch Binzel 25 AK / Pince de masse, Pince porte électrodes et Torche MIG/MAG 25 AK / Pinza de masa, Alicete porta electrodos y Antorcha MIG/MAG 25 AK



CÓDIGO  
CODE / CODE  
/ CÓDIGO

EMBALAGEM  
QUANTITY / EMBALLAGE  
/ EMBALAJE

009130000250

1

T100.20 H

200  
Amp

FACTOR DE MARCA  
100%  
EN 60974



Indicada para soldadura MMA e TIG | Ideal para soldar com eletrodos inox | Seletor soldadura MMA/TIG | Intensidade de corrente: 200 Amp | Fator de marcha 100% | Pode funcionar com geradores 6 Kva

Suitable for MMA and TIG HF welding | Ideal to weld with stainless steels | MMA/TIG welding selector | Powerful inverter 200 Amp | Duty cycle: 100% | Ready to operate with 6KVA generator

Indiqué pour soudage MMA et TIG | Idéal pour souder avec électrode inox | Sélecteur de soudure MMA/TIG | Puissance 200 Amp | Facteur de marche 100% | Fonctionne avec générateur 6KVA

Indicada para soldadura MMA y TIG | Ideal para soldar con electrodos inox | Selector soldadura MMA/TIG | Intensidad de corriente: 200 Amp | Factor de marcha 100% | Puede funcionar con generadores 6KVA

### Accessórios incluídos

/ Includes / Accessoires inclus / Accesorios incluidos

### Pinça de massa, Alicete porta eletrodos e Tocha TIG

Pure Copper Ground clamp, Pure Copper Electrode holder and Torch TIG / Pince de masse, Pince porte électrodes et Torche TIG / Pinza de masa, Alicete porta electrodos y Antorcha TIG



CÓDIGO  
CODE / CODE  
/ CÓDIGO

EMBALAGEM  
QUANTITY / EMBALLAGE  
/ EMBALAJE

009130010020

1

T40.20 PAH

200  
Amp

FACTOR DE MARCA  
40%  
EN 60974

IDEAL PARA ALUMINIO  
Ideal for aluminum | Idéal pour l'aluminium  
| Conforme la norme EN 60974



Indicada para soldadura MMA e TIG | Capacidade AC/DC incluindo arco pulsado | Ideal para soldar qualquer material. Especialmente em alumínio graças ao sistema de corrente alternada | Totalmente programável e através de um único botão | Pode funcionar com geradores 6 Kva

Suitable for MMA and TIG AC/DC rod welding | AC/DC capacity including pulse arc | Ideal for welding any material. Specially aluminium welding thanks to AC system | Fully programmable "only one button" easy configuration | Ready to operate with 6KVA generator

Indiqué pour soudage MMA et TIG | Capacité AC/DC incluant arc pulsé | Idéal pour souder tous matériaux. Spécialément aluminium grâce au système de courant alterné | Totalemt programmable avec un unique bouton | Fonctionne avec générateur 6KVA

Indicada para soldadura MMA y TIG | Capacidad AC/DC incluyendo arco pulsado | Ideal para soldar cualquier material especialmente en aluminio gracias al sistema de corriente alterna | Totalmente programable y a través de un único pulsador | Puede funcionar con generadores 6KVA

### Accessórios incluídos

/ Includes / Accessoires inclus / Accesorios incluidos

### Pinça de massa, Alicete porta eletrodos e Tocha TIG

Pure Copper Ground clamp, Pure Copper Electrode holder and Torch TIG / Pince de masse, Pince porte électrodes et Torche TIG / Pinza de masa, Alicete porta electrodos y Antorcha TIG



CÓDIGO  
CODE / CODE  
/ CÓDIGO

EMBALAGEM  
QUANTITY / EMBALLAGE  
/ EMBALAJE

009130040200

1



## Pistolas MIG/MAG

MIG/MAG Welding Torches / Torches MIG/MAG / Pistolas MIG/MAG



CÓDIGO CODE / CODE / CÓDIGO	COMPRIMENTO DO CABO CABLE SIZE / LONGUEUR DU CÂBLE / LARGO DEL CABLE	EMBALAGEM QUANTITY / EMBALLAGE / EMBALAJE
00916000253	3 m	1
00916000254	4 m	1



Em fábricas, na produção | Na manutenção e reparações | Na construção  
Shop production | Maintenance and repair | Construction  
En usines, dans la production | Dans la manutention et réparations | Dans la construction  
En fábricas, en la producción | En el mantenimiento y reparaciones | En la construcción

CÓDIGO CODE / CODE / CÓDIGO	COMPRIMENTO DO CABO CABLE SIZE / LONGUEUR DU CÂBLE / LARGO DEL CABLE	EMBALAGEM QUANTITY / EMBALLAGE / EMBALAJE
00916000363	3 m	1
00916000364	4 m	1



Em fábricas, na produção | Na manutenção e reparações | Na construção  
Shop production | Maintenance and repair | Construction  
En usines, dans la production | Dans la manutention et réparations | Dans la construction  
En fábricas, en la producción | En el mantenimiento y reparaciones | En la construcción



### MIG BZ 25



### MIG BZ 36

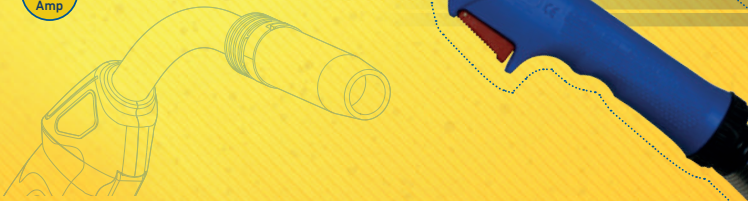

## Acessórios

Accessory / Accessoire / Accesorio



	CÓDIGO CODE / CODE / CÓDIGO	DIMENSÕES SIZE / DIMENSIONS / MEDIDA	EMBALAGEM QUANTITY / EMBALLAGE / EMBALAJE
1	- 009160116000	Ø 16	1
2	- 009160236000	-	1
3	BZ 25 009160125000	-	1
4	BZ 36 009160136000	-	1
5	BZ 25 009161000361	-	1
	BZ 36 009161000362	-	1
	- 009162806000	M6 x 28 Ø 0.6	1
	- 009162808000	M6 x 28 Ø 0.8	1
	- 009162810000	M6 x 28 Ø 1.0	1
	- 009162812000	M6 x 28 Ø 1.2	1
7	- 009161000363	0.6 - 0.8	1
	- 009161004000	1.0 - 1.2	1

## Tocha TIG c/ Válvula de Regulação

Torches TIG w/regulating valve / Torches TIG w/vanne de régulation / Antorcha TIG c/control de gas por válvula

Classe V / V Class / Classe V / Clase V	L
L2 Max (fator de marcha 35% DC) / L2 Max (duty cycle 35% DC) / L2 Max (facteur de marche 35% DC) / L2 Max (factor de marcha 35% DC)	180
L2 Max (fator de marcha 35% AC) / L2 Max (duty cycle 35% AC) / L2 Max (facteur de marche 35% AC) / L2 Max (factor de marcha 35% AC)	145
V (Arco ou DC) / V (Arc or DC) / V (Arc or DC) / V (Arco o DC)	AC - DC
Ø Fio / Ø Wire / Ø Fil / Ø Hilo	1 - 3.2
Gás / Gas / Gaz / Gas	Argon
Refrigeração / Cooling / refroidissement / refrigeración	6-12 U/min
Ligação / Connection / Conexión / conexión	10/25 3/8"
	35/50 1/2"
	Progress 1500 Progress 1700 Progress 180
	M40.20 MIG 250 T Progress 2000



CÓDIGO CODE / CODE / CÓDIGO	LIGAÇÃO CONNECTION / CONNECTION / CONEXIÓN	COMPRIMENTO DO CABO CABLE SIZE / LONGUEUR DU CÂBLE / LARGO DEL CABLE	EMBALAGEM QUANTITY / EMBALLAGE / EMBALAJE
009130015167	3/8" (10-25)	3 m	1
009130013167	1/2" (35-50)	4 m	1

## Pinça de Massa 500A

Welding Earth Clamp 500A / Pince de Masse 500A / Pinza de Masa 500A



1mm



CÓDIGO CODE / CODE / CÓDIGO	Amp	EMBALAGEM QUANTITY / EMBALLAGE / EMBALAJE
009171000500	500	1

## Alicate Porta Elérodos 300A / 500A

Welding Electrode Holder 300A/500A / Pince Porte-Électrodes 300A/500A / Alicate Portaelectrodos 300A/500A



CÓDIGO CODE / CODE / CÓDIGO	Amp	EMBALAGEM QUANTITY / EMBALLAGE / EMBALAJE
009170000300	300	1
009170000500	500	1

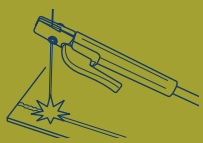

# SOLDADURA

Welding / Soudure / Soldadura

## Equipamento de Proteção Individual

Personal Protective Equipment / Équipement de Protection Individuel / Equipo de Protección Individual

### Avental de Soldador

Welder Apron / Tablier de Soudeur / Delantal Soldador

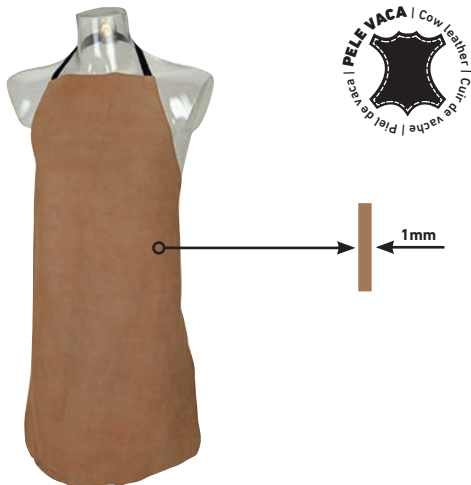

EN 340 | EN 470

CÓDIGO CODE / CODE / CÓDIGO	DIMENSÕES SIZE / DIMENSIONS / MEDIDA	EMBALAGEM QUANTITY / EMBALLAGE / EMBALAJE
005202005017	600 x 900	1

### Mangas de Soldador

Welding Leather Sleeves / Manchettes de Soudeur / Mangas Soldador



EN 340 | EN 470-1

CÓDIGO CODE / CODE / CÓDIGO	DIMENSÕES SIZE / DIMENSIONS / MEDIDA	EMBALAGEM QUANTITY / EMBALLAGE / EMBALAJE
005202005018	300	1

### Luvas de Soldador PM 516 / Welder Glove PM516 / Gants de Soudeur PM516 / Guantes de Soldador PM516

EN 388



4 2 2 4

EN 12477:2001



4,1,3,X,4,X



EN 420 CAT II

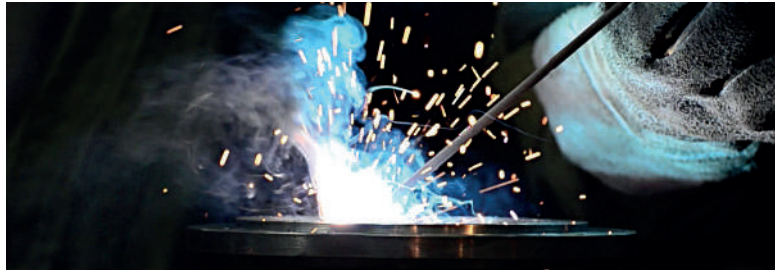

CÓDIGO CODE / CODE / CÓDIGO	DIMENSÕES SIZE / DIMENSIONS / MEDIDA	EMBALAGEM QUANTITY / EMBALLAGE / EMBALAJE
005205001510	330	1

### Máscara de Soldar Manual P0253

Manual Welding Mask P0253 / Masque de Soudure Manuel P0253 / Mascara Soldar Manual P0253



EN 175 CAT II



Leve e confortável | Perfeito para curtos períodos de solda ou supervisão | Filtros substituíveis

Lightweight and comfortable | Perfect to supervise or for short welding runs | Changeable screen filters

Léger et confortable | Parfait pour courtes périodes de soudure ou supervision | Filtres changeables

Leve y confortable | Perfecto para cortos periodos desoldadura o supervisión | Filtros sustituyibles

CÓDIGO CODE / CODE / CÓDIGO	EMBALAGEM QUANTITY / EMBALLAGE / EMBALAJE
005202005030	1
005202005031	1
005202005032	1

Vidro interno / Internal glass / Verre interne / Vidrio interno

Vidro exterior / External glass / Verre externe / Vidrio externo

### Óculos de Soldador P0204

Welding Goggles P0204 / Lunettes de Soudeur P0204 / Gafas de Soldador P0204



EN 175 F CAT II



Filtro DIN 5 articulado | 4 válvulas de ventilação | Ideal para soldadura por pontos e soldadura por arco

Liftable glass-lenses DIN 5 | 4 ventilation valves | Ideal for light electric spot welding and arc welding

Filtre DIN 5 articulé | 4 valves de ventilation | Idéale pour soudage par points et soudage à l'arc

Filtro DIN 5 articulado | 4 válvulas de ventilación | Ideal para soldadura por puntos o soldadura por arco

CÓDIGO CODE / CODE / CÓDIGO	EMBALAGEM QUANTITY / EMBALLAGE / EMBALAJE
005202001410	1

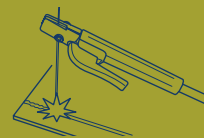

## Equipamento de Proteção Individual

Personal Protective Equipment / Équipement de Protection Individuel / Equipo de Protección Individual

### Máscara de Soldar Automática P0255

Auto Darkening TIG Welding Helmet P0255 / Masque de Soudure Auto-obscureissant TIG P0255 / Máscara de Soldar Automática P0255



CE DIN 379 : 2009 - 07



Muito ergonómica e confortável | Ajuste exterior do nível de proteção | Cartucho alimentado por energia solar - Pilhas não necessárias | Certificação CE

Very comfortable and ergonomic | Adjustable shade level from outside | Powered by solar cells - No batteries required | CE approval

Très confortable et ergonomique | Niveau de teinte ajustable de l'extérieur | Alimenté par cellules solaires - Ne nécessite pas de batterie | Norme CE

Muy ergonómica y confortable | Ajuste exterior del nivel de protección | Cartucho alimentado por energía solar - Pilas no necesarias | Certificación CE

	CÓDIGO CODE / CODE / CÓDIGO	EMBALAGEM QUANTITY / EMBALLAGE / EMBALAJE
	005202005050	1
Filtro fotoelétrico / Photo electric filter / Cellule Photoélectrique / Filtro Fotoeléctrico	005202005151	1
Lente proteção / Protective lens / Ecran de protection / Lente Protección	005205005152	1
Vidro proteção interior / Interior protective glass / Verre de protection intérieur / Vidrio Protección Interior	005202005153	1

### Máscara de Soldar Automática P0254

Auto Darkening Welding Helmet P0254 / Masque de Soudure Auto-Obscureissant P0254 / Máscara de Soldar Automática P0254



CE DIN 379 : 2009 - 07



Muito ergonómica e confortável | Ajuste exterior do nível de proteção | Cartucho alimentado por energia solar - Pilhas não necessárias | Certificação CE

Very comfortable and ergonomic | Adjustable shade level from outside | Powered by solar cells - No batteries required | CE approval

Très confortable et ergonomique | Niveau de teinte ajustable de l'extérieur | Alimenté par cellules solaires - Ne nécessite pas de batterie | Norme CE

Muy ergonómica y confortable | Ajuste exterior del nivel de protección | Cartucho alimentado por energía solar - Pilas no necesarias | Certificación CE

	CÓDIGO CODE / CODE / CÓDIGO	EMBALAGEM QUANTITY / EMBALLAGE / EMBALAJE
	005202005040	1
Filtro fotoelétrico / Photo electric filter / Cellule Photoélectrique / Filtro Fotoeléctrico	005202005251	1
Lente proteção / Protective lens / Ecran de protection / Lente Protección	005205005152	1
Vidro proteção interior / Interior protective glass / Verre de protection intérieur / Vidrio Protección Interior	005202005253	1



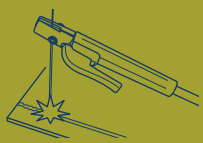

# SOLDADURA

Welding / Soudure / Soldadura

## Esquadro Magnético

Magnetic Square / Équerre Magnétique / Escuadra Magnética

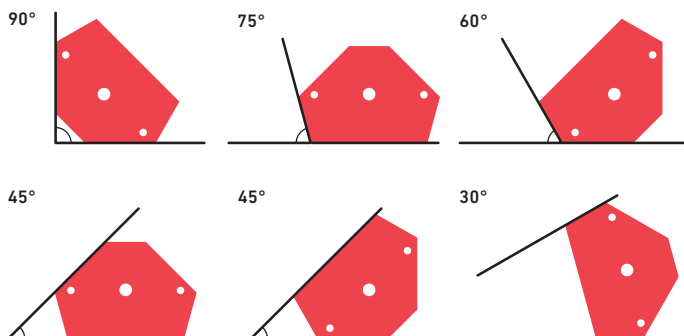
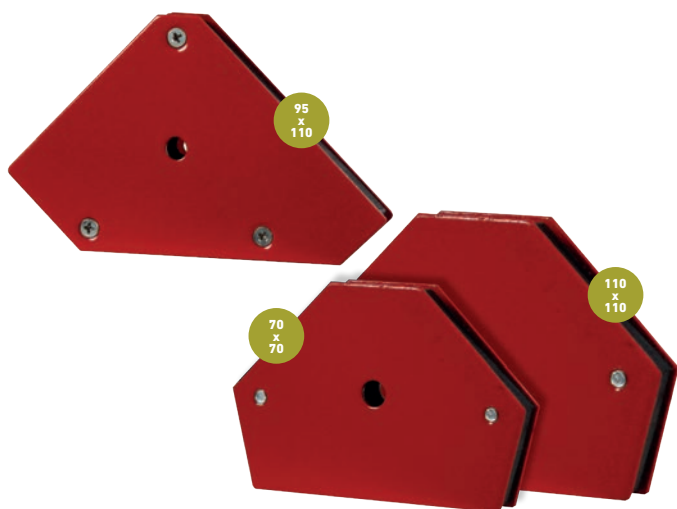

CÓDIGO CODE / CODE / CÓDIGO	DIMENSÕES SIZE / DIMENSIONS / MEDIDA	EMBALAGEM QUANTITY / EMBALLAGE / EMBALAJE
00000070070	70 x 70	1
00000095110	95 x 110	1
00000110110	110 x 110	1

## KIT Soldador e Decapagem MG300

Welding Kit MG 300 / Pack soudeur et décapage MG300 / KIT Soldador y Decapado MG300

2kW

1850°C

TEMPERATURA CHAMA  
Flame temperature  
/ Température de la flamme  
/ Temperatura de la llama

140g/h

CONSUMO  
Gas consumption /  
Consommation de gaz /  
Consumo de gas



Ø17  
mm

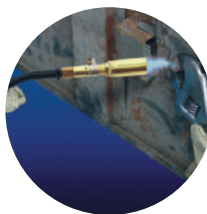

QUEIMADOR

Burner  
/ Brûleur  
/ Quemador

QUEIMADOR TUBOS

Tube burner  
/ Brûleur Carcoflam  
/ Tubos De Quemador

QUEIMADOR PLANO

Flat burner  
/ Brûleur Flamme Plate  
/ Quemador Plano



O KIT Soldador e Decapagem MG 300 é ideal para soldaduras, brasagem, trabalhos em metal, canalização, decapagem de pinturas e outros trabalhos.

Welding Kit MG 300 is perfect for welding, brazing, metal work, plumbing, pickling of paintings and other works.  
Le pack Soudeur et décapage MG 300 est indiqué pour les soudures, le brasage, travaux en métal, plomberie, décapage de peintures et autres travaux.

El KIT Soldador y decapado MG 300 es ideal para la soldadura, soldadura fuerte, trabajos en metal, canalizaciones, decapado de pinturas y otros trabajos.

CÓDIGO  
CODE / CODE  
/ CÓDIGO

03760000300

EMBALAGEM  
QUANTITY / EMBALLAGE  
/ EMBALAJE

1



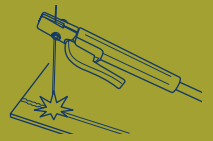

## Maçarico Turbo a Gás

Gas Blowtorches / Torche Turbo à Gaz / Soplete Turbo a Gas



### MG601

CONSUMO  
Gas consumption /  
Consommation de gaz /  
Consumo de gas

2500g/h

35kW

### MG600

CONSUMO  
Gas consumption /  
Consommation de gaz /  
Consumo de gas

2500g/h

35kW

### MG500

CONSUMO  
Gas consumption /  
Consommation de gaz /  
Consumo de gas

2000g/h

28kW

	CÓDIGO CODE / CODE / CÓDIGO	DIMENSÕES SIZE / DIMENSIONS / MEDIDA	EMBALAGEM QUANTITY / EMBALLAGE / EMBALAJE
MG 601	037600000700	Ø60 x 1000	1
MG 600	037600000600	Ø60 x 600	1
MG 500	037600000500	Ø50 x 400	1



O maçarico turbo a gás PECOL é ideal para decapagem de pinturas, asfaltamento, impermeabilizações e outros trabalhos de aquecimento | Também adequado para a desinfestação de insetos

The Pecol blowtorch are ideal tools for welding, soldering, brazing, metal works, plumbing, paint stripping, asphaltting, and other healthy jobs | Also suitable for insect desinfestation

La torche turbo à gaz PECOL est idéale pour la soudure, brasage, travaux sur métal, canalisation, décapage de peintures, travaux avec asphalte, imperméabilisations et autres travaux de réchauffement | Également adéquate pour la désinfections d'insectes

El soplete turbo a gas PECOL es ideal para soldaduras, brasado, trabajos en metal, canalización, decapado de pinturas, asfaltado, impermeabilizaciones y otros trabajos de calentamiento | También adecuado para la desinfestación de insectos



### MG607 PZ

CONSUMO  
Gas consumption /  
Consommation de gaz /  
Consumo de gas

2500g/h

35kW

	CÓDIGO CODE / CODE / CÓDIGO	DIMENSÕES SIZE / DIMENSIONS / MEDIDA	EMBALAGEM QUANTITY / EMBALLAGE / EMBALAJE
	037600000800	Ø60 x 700	1



O maçarico turbo a gás PECOL é ideal para decapagem de pinturas, asfaltamento, impermeabilizações e outros trabalhos de aquecimento | Também adequado para a desinfestação de insetos

The Pecol blowtorch are ideal tools for welding, soldering, brazing, metal works, plumbing, paint stripping, asphaltting, and other healthy jobs | Also suitable for insect desinfestation

La torche turbo à gaz PECOL est idéale pour la soudure, brasage, travaux sur métal, canalisation, décapage de peintures, travaux avec asphalte, imperméabilisations et autres travaux de réchauffement | Également adéquate pour la désinfections d'insectes

El soplete turbo a gas PECOL es ideal para soldaduras, brasado, trabajos en metal, canalización, decapado de pinturas, asfaltado, impermeabilizaciones y otros trabajos de calentamiento | También adecuado para la desinfestación de insectos

### Acessórios / Accessory / Accessoire / Accesorio

Válvula de Ligação p/ Garrafa Camping  
Standard - Connecting Valve / Robinet - standard  
/ Válvula de conexión - patrón

CÓDIGO CODE / CODE / CÓDIGO	EMBALAGEM QUANTITY / EMBALLAGE / EMBALAJE
037000000024	1

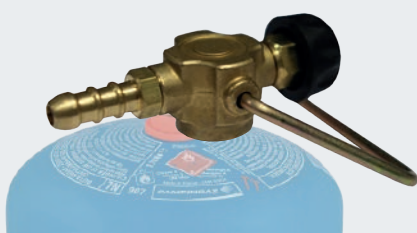

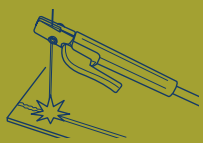

# SOLDADURA

Welding / Soudure / Soldadura

## Maçarico de Cartucho

Pierceable Cartridge Blowlamps / Chalumeau à Cartouche / Soplete de Cartucho

PEC 1850 PZ



1600°C

TEMPERATURA CHAMA  
Flame temperature / Température de la flamme / Temperatura de la llama

110g/h

CONSUMO  
Gas consumption / Consommation de gaz / Consumo de gas



**PIEZO ELÉTRICO**  
/automatic piezo ignition system / système d'ignition (brique) piézoélectrique / sistema de ignición (mechero) automático

CÓDIGO  
CODE / CODE / CÓDIGO

037000000008

EMBALAGEM  
QUANTITY / EMBALLAGE / EMBALAJE

1



Particularmente indicado para pequenas soldaduras, reparações, trabalhos domésticos, moldagem e aquecimento de plásticos, decapagem de pinturas e combustão de madeira

Particularly suitable for small repairs, do-it-yourself jobs, plastic folding and welding, paint stripping and wood drying

Particulièrement indiquée pour brasages, petites réparations, travaux domestiques, moulage ou chauffe de plastiques, décapage de peintures et combustion de bois

Particularmente indicado para pequeñas soldaduras, reparaciones, trabajos domésticos, moldeo y calentamiento de plásticos, decapado de pinturas y combustión de madera

PEC 1750

1600°C

127g/h



PEC 1750 PZ

1600°C

127g/h



**PIEZO ELÉTRICO**  
/automatic piezo ignition system / système d'ignition (brique) piézoélectrique / sistema de ignición (mechero) automático

CÓDIGO  
CODE / CODE / CÓDIGO

037000000006

EMBALAGEM  
QUANTITY / EMBALLAGE / EMBALAJE

1

PEC 1650 PZ

1600°C

127g/h



**PIEZO ELÉTRICO**  
/automatic piezo ignition system / système d'ignition (brique) piézoélectrique / sistema de ignición (mechero) automático

CÓDIGO  
CODE / CODE / CÓDIGO

037000000005

EMBALAGEM  
QUANTITY / EMBALLAGE / EMBALAJE

1

## Acessórios / Accessory / Accessoire / Accesorio

### Cartucho de gás 190 gr

Pierceable Gas Cartridge 190 grams / Cartouche de Gaz 190 gr / Cartucho de Gas 190 gr

CÓDIGO  
CODE / CODE / CÓDIGO

037000000010

EMBALAGEM  
QUANTITY / EMBALLAGE / EMBALAJE

48





# PROTEÇÃO E SEGURANÇA

SAFETY AND SECURITY  
PROTECTION ET SECURITÉ  
PROTECCIÓN Y SEGURIDAD



# PROTEÇÃO E SEGURANÇA

Safety and Security / Protection et Sécurité / Protección y Seguridad

## Proteção dos Pés

Foot Protection / Protection des Pieds / Protección de los Pies

### DIABLO

#### Sapato

/ Shoe / Chaussure / Zapato



CÓDIGO  
CODE / CODE  
/ CÓDIGO

0050030013...

DIMENSÕES  
SIZE / DIMENSIONS  
/ MEDIDA

37 - 45

### FLOW II

#### Sapato

/ Shoe / Chaussure / Zapato



CÓDIGO  
CODE / CODE  
/ CÓDIGO

0050030041...

DIMENSÕES  
SIZE / DIMENSIONS  
/ MEDIDA

39 - 45

### FLORIDA

#### Bota

/ Boot / Chaussure / Bota



CÓDIGO  
CODE / CODE  
/ CÓDIGO

0050010027...

DIMENSÕES  
SIZE / DIMENSIONS  
/ MEDIDA

37 - 47

### IRON

#### Bota

/ Boot / Chaussure / Bota



CÓDIGO  
CODE / CODE  
/ CÓDIGO

0050020011...

DIMENSÕES  
SIZE / DIMENSIONS  
/ MEDIDA

37 - 47

### STAR

#### Sapato

/ Shoe / Chaussure / Zapato



CÓDIGO  
CODE / CODE  
/ CÓDIGO

0050010011...

DIMENSÕES  
SIZE / DIMENSIONS  
/ MEDIDA

37 - 47

### DENVER

#### Sapato

/ Shoe / Chaussure / Zapato



CÓDIGO  
CODE / CODE  
/ CÓDIGO

0050020029...

DIMENSÕES  
SIZE / DIMENSIONS  
/ MEDIDA

36 - 46



### Requisitos segurança / Safety requirements / Conditions de sécurité / Requisitos Seguridad

		Tipo I					Tipo II	
		S1	S2	S3	S4	S5		
<b>Sola</b>	SB *	Requisitos básicos / Basic Requirements / Conditions basiques / Requisitos básicos						
Whole shoe / Semelle / Suela	P	Sola intermédia resistente à perfuração / Penetration resistant midsole / Semelle intermédiaire résistante à la perforation / Suela intermedia resistente a la perforación						
	C	Sapato condutivo / Conductive shoe / Chaussure conductrice/ Zapato conductivo						
	A	Sapato anti-estático / Antistatic shoe / Chaussure antistatique / Zapato antiestático						
	I	Sapato com isolamento elétrico / Electrically insulated shoe / Chaussure avec isolation électrique / Zapato con aislamiento eléctrico						
	HI	Sola com isolamento térmico (calor) / Heat-insulated sole / Semelle avec isolation thermique (chaleur) / Suela con aislamiento térmico (calor)						
	CI	Sola com isolamento térmico (frio) / Sole insulated against cold / Semelle avec isolation thermique (froid) / Suela con aislamiento térmico (frio)						
	E	Sola Anti-choque / Energy absorbing heel / Semelle Anti-choc / Suela Antichoque						
	WR	Calçado resistente à água / Water-resistant sole/upper junction in leather shoes / Chaussure résistante à l'eau / Calzado resistente al agua						
	M	Proteção do metatarso contra impacto / Metatarsal impact protection / Protection du métatarse contre impact / Protección del metatarso contra impacto						
<b>Gáspea</b>	WRU	Resistência à penetração e absorção de água / Water-resistant upper for leather shoes / Résistante à la pénétration et absorption d'eau / Resistencia a la penetración y absorción de agua						
Upper / Tige / Gáspea	CR	Tecido resistente aos cortes / Cut-resistant upper / Tissu résistant aux coupes / Tejido resistente a los cortes						
<b>Sola exterior</b> / Outsole / Semelle extérieure / Suela exterior	HRO	Sola externa resistente ao calor por contacto / Contact-heat resistant outsole / Semelle externe résistante à la chaleur par contact / Suela externa resistente ao calor por contacto						
	FO	Sola exterior resistente a óleos / Oil-resistant outsole / Semelle extérieure résistant aux huiles / Suela exterior resistente a aceites						

■ REQUISITOS OBRIGATORIOS / Mandatory requirement / Conditions obligatoires / Requisitos obligatorios | □ REQUISITOS OPCIONAIS / Optional requirement / Conditions optionnelles / Requisitos opcionales



## Proteção dos Pés

Foot Protection / Protection des Pieds / Protección de los Pies

### SNAKE

### Sapato

/ Shoe / Chaussure / Zapato



Também disponível em COR CINZA  
/ Also available in grey  
/ Aussi disponible en gris  
/ También disponible en gris



**CÓDIGO**  
CODE / CODE  
/ CÓDIGO

**DIMENSÕES**  
SIZE / DIMENSIONS  
/ MEDIDA

0050030065...

36 - 45

### BEAT TEXTILE

### Sapato

/ Shoe / Chaussure / Zapato



**CÓDIGO**  
CODE / CODE  
/ CÓDIGO

**DIMENSÕES**  
SIZE / DIMENSIONS  
/ MEDIDA

0050030014...

38 - 45

### OUTDOOR

### Sapato

/ Shoe / Chaussure / Zapato



**CÓDIGO**  
CODE / CODE  
/ CÓDIGO

**DIMENSÕES**  
SIZE / DIMENSIONS  
/ MEDIDA

0050010020...

38 - 45

### TRECK

### Sapato

/ Shoe / Chaussure / Zapato



**CÓDIGO**  
CODE / CODE  
/ CÓDIGO

**DIMENSÕES**  
SIZE / DIMENSIONS  
/ MEDIDA

0050010012...

37 - 47

### Spider

### Sapato

/ Shoe / Chaussure / Zapato



**CÓDIGO**  
CODE / CODE  
/ CÓDIGO

**DIMENSÕES**  
SIZE / DIMENSIONS  
/ MEDIDA

0050030057...

36 - 45

### BETA S5

### Galocha

/ Boot / Botte / Bota



**CÓDIGO**  
CODE / CODE  
/ CÓDIGO

**DIMENSÕES**  
SIZE / DIMENSIONS  
/ MEDIDA

0050020022...

38 - 45



#### SIMBOLÓGIA / symbols / symboles / símbolos



**RESISTENTE À PENETRAÇÃO DE ÁGUA**  
/ water resistant  
/ Résistance à la pénétration d'eau  
/ Resistente a la penetración de agua



**ANTI-ESTÁTICO**  
/ Anti static  
/ Antistatique  
/ Antiestático



**ABS. DE ENERGIA NO CALCANHAR**  
/ Shock-absorber outsole  
/ Semelle Anti-Choc  
/ Suela Antichoque



**RESISTENTE À PERFURAÇÃO**  
/ Anti-perforation sole  
/ Résistance à la perforation  
/ Resistente a la perforación



**SOLA RESISTENTE À TRANSMISSÃO DE CALOR**  
/ Sole resistant to heat transmission by contact  
/ Semelle résistante à la chaleur par contact  
/ Suela resistente al calor por contacto



**SOLA RESISTENTE A ÓLEOS**  
/ Oil resistant outsole  
/ Semelle résistante aux huiles  
/ Suela resistente a aceites



**RESISTENTE A IMPACTOS DE 200J**  
/ Impact resistant toecap - 200J  
/ Résistance aux impacts de 200J  
/ Resistente a impactos de 200J



**SOLA ANTI-DERRAPANTE**  
/ Slip resistant outsole  
/ Semelle antidérapante  
/ Suela Antideslizante



**SAPATO NÃO METÁLICO**  
/ Non Metallic  
/ Non métallique  
/ No Metálico



**FORRO TÉRMICO**  
/ Thermic lining  
/ Doublure thermique  
/ Forro termico



Consulte a restante gama de  
**PROTEÇÃO E SEGURANÇA**

/ Check the entire collection / Vérifiez toute la collection / Compruebe toda la colección



# PROTEÇÃO E SEGURANÇA

Safety and Security / Protection et Sécurité / Protección y Seguridad

## Proteção das Mãos

Hand Protection / Protection des Mains / Protección de las Manos

381

**Luva de Nitrilo**  
/ Nitrile Glove / Gants Nitrile  
/ Guante Nitrilo

SHOWA



EN 388



4 1 2 1



CÓDIGO CODE / CODE / CÓDIGO	DIMENSÕES SIZE / DIMENSIONS / MEDIDA	EMBALAGEM QUANTITY / EMBALLAGE / EMBALAJE
00520553900...	6 - 9	12

380

**Luva Espuma de Nitrilo**  
/ Nitrile Foam Glove  
/ Gants Mousse de Nitrile  
/ Guante Espuma de Nitrilo

SHOWA



EN 388



3 1 2 1



CÓDIGO CODE / CODE / CÓDIGO	DIMENSÕES SIZE / DIMENSIONS / MEDIDA	EMBALAGEM QUANTITY / EMBALLAGE / EMBALAJE
0052055380...	6 - 9	12

376

**Luva de Nitrilo**  
/ Nitrile Glove / Gants Nitrile  
/ Guante Nitrilo

SHOWA

Também disponível em ANTI-CORTE S-TEX 376  
/ Also available with cut-resistant S-TEX 376  
/ Également disponible avec protection contre les coupures / También disponible con protección al corte



EN 388



4 1 2 1



CÓDIGO CODE / CODE / CÓDIGO	DIMENSÕES SIZE / DIMENSIONS / MEDIDA	EMBALAGEM QUANTITY / EMBALLAGE / EMBALAJE
0052055376...	6 - 9	12

PM508

**Luva de Nitrilo**  
/ Nitrile Glove / Gants Nitrile  
/ Guante Nitrilo



EN 420

EN 388



4 1 2 1



CÓDIGO CODE / CODE / CÓDIGO	DIMENSÕES SIZE / DIMENSIONS / MEDIDA	EMBALAGEM QUANTITY / EMBALLAGE / EMBALAJE
0052050011..	7 - 10	12

B0500

**Luva PU**  
/ Polyurethane Coating Glove  
/ Gant revêtu de polyuréthane  
/ Guante revestido en poliuretano

SHOWA



EN 388



3 1 3 1



CÓDIGO CODE / CODE / CÓDIGO	DIMENSÕES SIZE / DIMENSIONS / MEDIDA	EMBALAGEM QUANTITY / EMBALLAGE / EMBALAJE
0052055500...	6 - 9	12

PM509

**Luva PU**  
/ Polyurethane Coating Glove  
/ Gant revêtu de polyuréthane  
/ Guante revestido en poliuretano



EN 420

EN 388



4 1 3 1



CÓDIGO CODE / CODE / CÓDIGO	DIMENSÕES SIZE / DIMENSIONS / MEDIDA	EMBALAGEM QUANTITY / EMBALLAGE / EMBALAJE
0052050013...	7 - 10	12

341

**Luva Latex**  
/ Latex Glove / Gant Latex  
/ Guante Látex

SHOWA



EN 388



2 1 2 1



CÓDIGO CODE / CODE / CÓDIGO	DIMENSÕES SIZE / DIMENSIONS / MEDIDA	EMBALAGEM QUANTITY / EMBALLAGE / EMBALAJE
0052055341..	6 - 9	12

PM510

**Luva Latex**  
/ Latex Glove / Gant Latex  
/ Guante Látex



EN 420

EN 388



2 1 2 1



CÓDIGO CODE / CODE / CÓDIGO	DIMENSÕES SIZE / DIMENSIONS / MEDIDA	EMBALAGEM QUANTITY / EMBALLAGE / EMBALAJE
0052050014...	7 - 10	12



EN 388



A B C D

**EN 388**

RISCOS MECÂNICOS / MECHANICAL RISKS / RISQUES MÉCANIQUES / RIESGOS MECÁNICOS

A norma EN388 aplica-se a todas as classes de luvas de protecção no referente às agressões físicas e mecânicas por abrasão (A), corte (B), perfuração (C) e desgarre (D). Esta norma não se aplica às luvas anti-vibratórias.  
/ The EN388 standard applies to all types of protective gloves with respect to physical and mechanical aggression from abrasion (A), cutting from slicing (B), perforation (C) and tearing (D). / La norme EN 388 s'applique à toutes les classes de gants de protection en ce qui concerne les agressions physiques et mécaniques par abrasion (A), coupe (B), perforation (C) et déchirure (D). Cette norme ne s'applique pas aux gants anti-vibratoires.  
/ La norma EN388 se aplica a todas las clases de guantes de protección en el referente a las agresiones físicas y mecánicas por abrasión (A), corte (B), perforación (C) y desgarre (D). Esta norma no se aplica a los guantes antivibratorios.

NÍVEIS DE PERFORMANCE / PERFORMANCE LEVELS / NIVEAU DE PERFORMANCE / NIVELES DE PRESTACIÓN

Nível / Level / Niveau / Niveles	1	2	3	4	5
<b>A</b> N° Ciclos / number of cycles / nombre de cycles / Numero de ciclos	100	500	2000	8000	-
<b>B</b> Índice / index / indice / índice	1,2	2,5	5,0	10,0	20
<b>C</b>	N	10	25	50	75
<b>D</b>	N	20	60	100	150

SIMBOLOGIA / symbols / symboles / símbolos



**ANTI-CORTE**  
/ cut-resistant  
/ anti-coupures  
/ proteccion al corte



## Proteção das Mãos

Hand Protection / Protection des Mains / Protección de las Manos

541

**Luva PU**  
/ Polyurethane Coating Glove  
/ Gant revêtu de polyuréthane  
/ Guante revestido en poliuretano

SHOWA

CE

EN 388



4 3 4 2

Luva Anti-Corte / cut-resistant / anti-coupures / protección al corte



CÓDIGO CODE / CODE / CÓDIGO	DIMENSÕES SIZE / DIMENSIONS / MEDIDA	EMBALAGEM QUANTITY / EMBALLAGE / EMBALAJE
0052055740..	7 - 9	12



660

**Luva PVC**  
/ PVC Glove / Gant PVC  
/ Guante PVC

SHOWA



CE

EN 388



4 1 2 1

EN 374-3



J K L

EN 374-2



LISTA DE QUÍMICOS  
Chemicals list  
Liste des produits chimiques  
Lista de productos químicos



CÓDIGO CODE / CODE / CÓDIGO	DIMENSÕES SIZE / DIMENSIONS / MEDIDA	EMBALAGEM QUANTITY / EMBALLAGE / EMBALAJE
0052055660...	8 - 11	12

PM504

**Luva de Pele**  
/ Leather glove  
/ Gant Cuir / Guante Piel



EN 388



4 2 4 4

CE

EN 420



CÓDIGO CODE / CODE / CÓDIGO	DIMENSÕES SIZE / DIMENSIONS / MEDIDA	EMBALAGEM QUANTITY / EMBALLAGE / EMBALAJE
005205001230	10,5	12

PM516

**Luva soldador**  
/ Welder Glove / Gants  
de Soudeur / Guantes de  
Soldador



EN 388



4 2 2 3

CE

EN 420

CAT II



CÓDIGO CODE / CODE / CÓDIGO	DIMENSÕES SIZE / DIMENSIONS / MEDIDA	EMBALAGEM QUANTITY / EMBALLAGE / EMBALAJE
005205001510	330 mm	1

PM521

**Luva de Pele**  
/ Leather glove  
/ Gant Cuir / Guante Piel



EN 388



4 1 2 3

CE

EN 420



CÓDIGO CODE / CODE / CÓDIGO	DIMENSÕES SIZE / DIMENSIONS / MEDIDA	EMBALAGEM QUANTITY / EMBALLAGE / EMBALAJE
005205001630	10,5	12

PM505

**Luva de Pele**  
/ Leather glove  
/ Gant Cuir / Guante Piel



EN 388



4 1 2 3

CE

EN 420



CÓDIGO CODE / CODE / CÓDIGO	DIMENSÕES SIZE / DIMENSIONS / MEDIDA	EMBALAGEM QUANTITY / EMBALLAGE / EMBALAJE
00520500161...	9 - 10,5	12



Consulte a restante gama de  
**PROTEÇÃO E SEGURANÇA**

/ Check the entire collection / Vérifiez toute la collection / Compruebe toda la colección



# PROTEÇÃO E SEGURANÇA

Safety and Security / Protection et Sécurité / Protección y Seguridad

## Proteção do Corpo

Body Protection / Protection du Corps / Protección del Cuerpo

TEXO

**Colete**

/ Vest / Gilet / Chaleco



**CÓDIGO**  
CODE / CODE  
/ CÓDIGO

005003004708/09/10/11

**DIMENSÕES**  
SIZE / DIMENSIONS  
/ MEDIDA

S / M / L / XL

TEXO

**Casaco**

/ Jacket / Veste / Chaqueta



**CÓDIGO**  
CODE / CODE  
/ CÓDIGO

005003004704/05/06/07

**DIMENSÕES**  
SIZE / DIMENSIONS  
/ MEDIDA

S / M / L / XL

TEXO

**Calça**

/ Trousers / Pantalon /  
Pantalones



**CÓDIGO**  
CODE / CODE  
/ CÓDIGO

005003004700/01/02/03

**DIMENSÕES**  
SIZE / DIMENSIONS  
/ MEDIDA

S / M / L / XL

SEATTLE

**Colete**

/ Vest / Gilet / Chaleco



**CÓDIGO**  
CODE / CODE  
/ CÓDIGO

005003004724/25/26/27

**DIMENSÕES**  
SIZE / DIMENSIONS  
/ MEDIDA

S / M / L / XL

SOFTSHELL

**Casaco**

/ Jacket / Veste / Chaqueta



**CÓDIGO**  
CODE / CODE  
/ CÓDIGO

005003004712/13/14/15

**DIMENSÕES**  
SIZE / DIMENSIONS  
/ MEDIDA

S / M / L / XL

WORK

**Bata**

/ Long Coat / Veste / Bata



**CÓDIGO**  
CODE / CODE  
/ CÓDIGO

005105003210/20/30/40

**DIMENSÕES**  
SIZE / DIMENSIONS  
/ MEDIDA

S / M / L / XL

POSH

**Casaco**

/ Jacket / Veste / Chaqueta



**CÓDIGO**  
CODE / CODE  
/ CÓDIGO

005003004613/14/15

**DIMENSÕES**  
SIZE / DIMENSIONS  
/ MEDIDA

S / M / L / XL

ATLAR II

**Polo**

/ Polo / Polo / Polo



**CÓDIGO**  
CODE / CODE  
/ CÓDIGO

0050030033..

**DIMENSÕES**  
SIZE / DIMENSIONS  
/ MEDIDA

S / M / L / XL



**SIMBOLÓGIA** / symbols / symboles / símbolos



**IMPERMEÁVEL** / Waterproof / Étanche / Impermeable



**ALTA VISIBILIDADE** / High Visibility / Haute Visibilité / Alta Visibilidad





## Proteção do Corpo

Body Protection / Protection du Corps / Protección del Cuerpo

TRABALHO

**Casaco**

/ Jacket / Veste / Chaqueta



CÓDIGO  
CODE / CODE  
/ CÓDIGO

0051011016...

DIMENSÕES  
SIZE / DIMENSIONS  
/ MEDIDA

S / M / L / XL

TRABALHO

**Calça**

/ Trousers / Pantalon /  
Pantalones



CÓDIGO  
CODE / CODE  
/ CÓDIGO

0051110110..

DIMENSÕES  
SIZE / DIMENSIONS  
/ MEDIDA

S / M / L / XL

AV100

**Colete**

/ Vest / Gilet / Chaleco



CÓDIGO  
CODE / CODE  
/ CÓDIGO

0051022011..

DIMENSÕES  
SIZE / DIMENSIONS  
/ MEDIDA

S / M / L / XL

INSTALADOR

**Colete**

/ Vest / Gilet / Chaleco



CÓDIGO  
CODE / CODE  
/ CÓDIGO

005102001300/10/20/30

DIMENSÕES  
SIZE / DIMENSIONS  
/ MEDIDA

S / M / L / XL

005102001210/20/30

M / L / XL

AV700

**Parka**

/ Parka / Parka / Parka



CÓDIGO  
CODE / CODE  
/ CÓDIGO

0051110110..

DIMENSÕES  
SIZE / DIMENSIONS  
/ MEDIDA

S / M / L / XL

AV701

**Calça**

/ Trousers / Pantalon /  
Pantalones

CÓDIGO  
CODE / CODE  
/ CÓDIGO

AV700 005003004716/17/18/19

AV701 005003004720/21/22/23

DIMENSÕES  
SIZE / DIMENSIONS  
/ MEDIDA

S / M / L / XL

S / M / L / XL

PERSONALIZAÇÃO

/ Customization / Personnalisation / Personalización

Personalizamos a sua roupa de trabalho com a sua MARCA.  
Entre em contacto connosco para saber mais...

/ Customize your garment with your brand. Contact us...  
/ Personnalisez votre vêtement avec votre marque. Contactez-nous...  
/ Personalice sus prendas con su marca. Contacte con nosotros...



QR  
CODE



Consulte a restante gama de  
**PROTEÇÃO E SEGURANÇA**

/ Check the entire collection / Vérifiez toute la collection / Compruebe toda la colección



QR  
CODE



# PROTEÇÃO E SEGURANÇA

Safety and Security / Protection et Sécurité / Protección y Seguridad

## Proteção da Cabeça

Head Protection / Protection de la Tête / Protección de la Cabeza

PC101/102

**Capacete Segurança**  
/ Safety Helmet / Casque de Sécurité / Casco Seguridad



CÓDIGO CODE / CODE / CÓDIGO	DIMENSÕES SIZE / DIMENSIONS / MEDIDA	EMBALAGEM QUANTITY / EMBALLAGE / EMBALAJE
005201001...	52x60	1

P0201/202

**Óculos de Proteção**  
/ Safety Glasses / Lunettes de Protection / Gafas de Protección



	CÓDIGO CODE / CODE / CÓDIGO	EMBALAGEM QUANTITY / EMBALLAGE / EMBALAJE
P0201	005202001110	1
P0202	005202001210	1

PR401/402/404/403

**Máscara**  
/ Respiratory Protection  
/ Protection Respiratoire  
/ Protección Respiratoria



	CÓDIGO CODE / CODE / CÓDIGO	EMBALAGEM QUANTITY / EMBALLAGE / EMBALAJE
PR401	005204001110	1
PR402	005204001210	1
PR404	0052040014...	1
PR403	0052040013...	1

P0205/206

**Viseira de Proteção**  
/ Face Shield / Visière  
/ Visera



	CÓDIGO CODE / CODE / CÓDIGO	EMBALAGEM QUANTITY / EMBALLAGE / EMBALAJE
P0205	005202001510	1
P0206	005202001610	1

PA302/311

**Protetores Auriculares**  
/ Hearing Protection / Protection  
Auditive / Protección Auricular



	CÓDIGO CODE / CODE / CÓDIGO	EMBALAGEM QUANTITY / EMBALLAGE / EMBALAJE
PA302	005203001110	1
PA311	005203101110	20

## Cintas de Carga

Slings and Ratchet / Sangles / Eslingas y trinquetes



CÓDIGO CODE / CODE / CÓDIGO	CARGA	CÓDIGO CODE / CODE / CÓDIGO	CARGA	CÓDIGO CODE / CODE / CÓDIGO	CARGA
012204301000	3000 kg	012200200300	2000 kg	012201200600	2000 kg
012204401000	4000 kg	012200200400	2000 kg	012201200800	2000 kg
012204501000	5000 kg	012200200600	2000 kg		

## Arnês de Segurança

Safety Harness / Harnais de Sécurité / Arnês de Seguridad



	CÓDIGO CODE / CODE / CÓDIGO	EMBALAGEM QUANTITY / EMBALLAGE / EMBALAJE
PAQ47	012204000000	1
PAQ45	012205000000	1



Consulte a restante gama de **PROTEÇÃO E SEGURANÇA**

/ Check the entire collection / Vérifiez toute la collection / Compruebe toda la colección





## Produtos de Limpeza

Hand cleaners / Produits de Nettoyage / Productos de Limpieza

### Creme Lava Mãos Fresh Special

Hand cleaner Fresh Special / Crème Nettoyante Mains Fresh Special / Crema Lavamanos Fresh Special



CÓDIGO CODE / CODE / CÓDIGO	CAPACIDADE CAPACITY / CAPACITÉ / CAPACIDAD	EMBALAGEM QUANTITY / EMBALLAGE / EMBALAJE
001026000013	1 L	1



**Ideal p/ limpeza de sujidade gordá**  
Ideal cleaning grease dirt  
Idéal p/ nettoyage de saleté grasse  
Ideal p/ limpeza de suciedad gordá

### Creme Lava Mãos Premium

Hand cleaner Premium / Pâte Nettoyante Mains Premium / Masa Lavamanos Premium



**Suporte de parede para creme lava mãos Premium**  
/ Metallic wall Dispenser for dosing pump for Cream  
Hands cleaner Premium / Support de mur pour Crème  
Nettoyante Mains Premium / Soporte de pared para crema  
lavamanos Premium

CÓDIGO CODE / CODE / CÓDIGO	CAPACIDADE CAPACITY / CAPACITÉ / CAPACIDAD	EMBALAGEM QUANTITY / EMBALLAGE / EMBALAJE
001026000006	5 L	1
001026000008	-	1



**Ideal p/ limpeza de sujidade seca e gordurosa**  
Ideal for cleaning dry and greasy dirt  
Idéal pour nettoyer la saleté sèche et grasse  
Ideal para limpieza de suciedad seca y grasa

### Pasta Lava Mãos Classic

Hand Cleaner Classic / Pâte Nettoyante Mains Classic / Pasta Lavamanos Classic



CÓDIGO CODE / CODE / CÓDIGO	CAPACIDADE CAPACITY / CAPACITÉ / CAPACIDAD	EMBALAGEM QUANTITY / EMBALLAGE / EMBALAJE
001026000007	4 L	1



**Ideal p/ limpeza de sujidade gordá**  
Ideal cleaning grease dirt  
Idéal p/ nettoyage de saleté grasse  
Ideal p/ limpeza de suciedad gordá

### Massa Lava Mãos Special

Hand cleaner Special / Pâte Nettoyante Mains Special / Masa Lavamanos Special



**Suporte parede para Massa  
Lava Mãos P260 Special**  
/ Wall Dispenser for Hand cleaner Special  
/ Support de mur pour Pâte Nettoyante  
Mains P260 Special / Soporte de pared  
para Masa Lavamanos P260 Special

**Bomba para Massa Lava Mãos  
P260 Special**  
/ Dosing Pump for Hand cleaner Special  
/ Pompe pour Pâte Nettoyante Mains  
Special / Bomba para Masa Lavamanos  
P260 Special

CÓDIGO CODE / CODE / CÓDIGO	CAPACIDADE CAPACITY / CAPACITÉ / CAPACIDAD	EMBALAGEM QUANTITY / EMBALLAGE / EMBALAJE
001026000001	4,5 L	1
001026000005	-	1
001026000002	-	1



**Ideal p/ limpeza de sujidade gordá**  
Ideal cleaning grease dirt  
Idéal p/ nettoyage de saleté grasse  
Ideal p/ limpeza de suciedad gordá

### Toalhitas de Limpeza / Cleaning Wipes

/ Lingettes de Nettoyage / Toallitas de Limpieza



CÓDIGO CODE / CODE / CÓDIGO	CAPACIDADE CAPACITY / CAPACITÉ / CAPACIDAD	EMBALAGEM QUANTITY / EMBALLAGE / EMBALAJE
001026000004	75 Toalhitas	1



**Ideal para remover óleos, gorduras, colas, silicones das mãos e ferramentas**  
Ideal to remove oil, grease, adhesives, silicones hands and tool cleaning  
Idéal pour retirer huiles, graisses, colles, silicones des mains et outils  
Ideal para eliminar aceites, grasas, pegamentos, silicones de las manos y herramientas

### Sabonete Líquido

/ Liquid soap / Savon liquide / Jábón Líquido



CÓDIGO CODE / CODE / CÓDIGO	CAPACIDADE CAPACITY / CAPACITÉ / CAPACIDAD	EMBALAGEM QUANTITY / EMBALLAGE / EMBALAJE
001026000015	500 ml	1
001026000017	5 L	1



**Ideal p/ oficinas automóvel, todo o tipo de indústria, restauração e uso doméstico.**  
Ideal for car workshops, all kind of industry, catering and domestic use  
Idéal pour les ateliers de réparation automobile, tous types d'industrie, de restauration et d'usage domestique  
Ideal para talleres de automóviles, todo el tipo de industria, restauración y uso doméstico



**O SEU FORNECEDOR DE SEMPRE,  
ONDE ESTIVER!**

*/ Your ever-ready supplier, wherever you are! / Votre fournisseur de toujours, où que vous soyez! / Su proveedor de siempre, donde esté!*

[HTTP://STORE.PECOL.PT/](http://store.pecol.pt/)

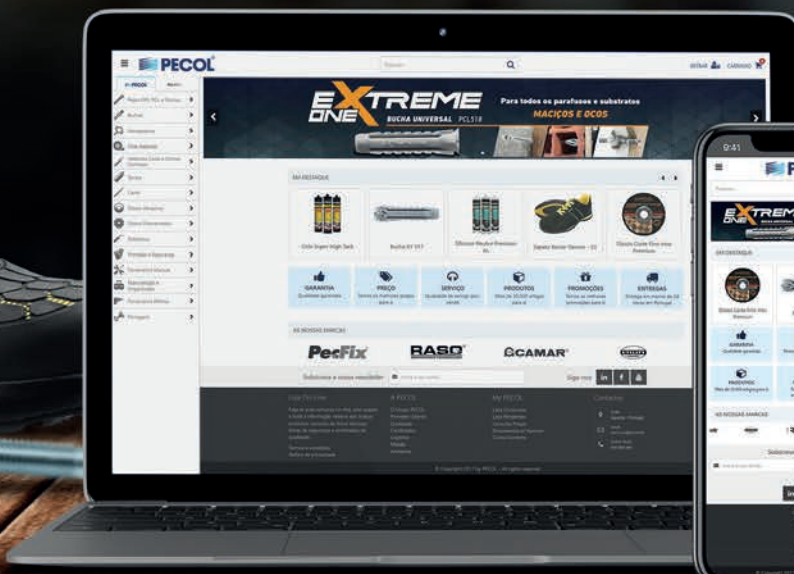



# FERRAMENTA MANUAL

*HAND TOOLS  
OUTILLAGE MANUEL  
HERRAMIENTA MANUAL*



# FERRAMENTA MANUAL

Hand Tools / Outillage Manuel / Herramienta Manual

## Chaves de Aperto

Wrenches / Clés de serrage / Llaves de Apriete

### Chave Phillips

Phillips Screwdrivers / Lame Phillips / Destornillador Phillips



**DIMENSÕES (mm)**  
/ SIZE (mm) / DIMENSIONS (mm) / MEDIDA (mm)  
PH0 x 75mm - PH1 x 100 mm - PH2 x 125 mm

CÓDIGO CODE / CODE / CÓDIGO	TIPO DE PONTEIRA / HEAD TYPE / TYPE DE POINTE / TIPO DE PUNTA	DIMENSÕES / SIZE / DIMENSIONS / MEDIDA	EMBALAGEM QUANTITY / EMBALLAGE / EMBALAJE
000011000226	PH0	75	1
000011000227	PH1	100	1
000011000228	PH2	125	1
000011000809	PH3	150	1
000011001066	PH4	200	1

### Chave Pozidrive

Pozidriv Screwdrivers / Lame Pozidriv / Destornillador Pozidriv



**DIMENSÕES (mm)**  
/ SIZE (mm) / DIMENSIONS (mm) / MEDIDA (mm)  
PZ0 x 75mm - PZ1 x 100 mm - PZ2 x 125 mm

CÓDIGO CODE / CODE / CÓDIGO	TIPO DE PONTEIRA / HEAD TYPE / TYPE DE POINTE / TIPO DE PUNTA	DIMENSÕES / SIZE / DIMENSIONS / MEDIDA	EMBALAGEM QUANTITY / EMBALLAGE / EMBALAJE
000011000247	PZ0	75	1
000011000248	PZ1	100	1
000011000249	PZ2	125	1
000011000628	PZ3	150	1

### Chave Fenda VDE

Slotted insulated Screwdrivers / Lame Fraisée pour Vis à Fente / Destornillador Boca Plana



**DIMENSÕES (mm)**  
/ SIZE (mm) / DIMENSIONS (mm) / MEDIDA (mm)  
0,4x2,5 x 100 mm - 1x5,5 x 125 mm

CÓDIGO CODE / CODE / CÓDIGO	TIPO DE PONTEIRA / HEAD TYPE / TYPE DE POINTE / TIPO DE PUNTA	DIMENSÕES / SIZE / DIMENSIONS / MEDIDA	EMBALAGEM QUANTITY / EMBALLAGE / EMBALAJE
000011000529	0,4x2,5	100	1
000011000528	1x5,5	125	1

### Chave Phillips VDE

Phillips insulated Screwdrivers / Lame Phillips / Destornillador Phillips



**DIMENSÕES (mm)**  
/ SIZE (mm) / DIMENSIONS (mm) / MEDIDA (mm)  
PH1 x 150 mm - PH2 x 175 mm

CÓDIGO CODE / CODE / CÓDIGO	TIPO DE PONTEIRA / HEAD TYPE / TYPE DE POINTE / TIPO DE PUNTA	DIMENSÕES / SIZE / DIMENSIONS / MEDIDA	EMBALAGEM QUANTITY / EMBALLAGE / EMBALAJE
000011000761	PH1	150	1
000011000530	PH2	175	1

### Conjunto Chave Fenda-Phillips

Screwdriver Set / Jeu de Tournevis / Juego Plano-Phillips



**DIMENSÕES / SIZE / DIMENSIONS / MEDIDA**

FENDA	0.5x3.0x75	0.8x4.0x100	1.0x5.5x125	1.2x6.5x150
PHILLIPS	1x100	2x125	-	-

**CÓDIGO**  
CODE / CODE / CÓDIGO

**EMBALAGEM**  
QUANTITY / EMBALLAGE / EMBALAJE

000011000233

1

### Conjunto Chave Fenda-Phillips VDE

Insulated Screwdriver Set / Jeu de Tournevis VDE / Juego Plano-Phillips VDE



IEC 60900



1000V



**DIMENSÕES / SIZE / DIMENSIONS / MEDIDA**

FENDA	0.4x2.5x100	0.8x4.0x100	1.0x5.5x125	1.2x6.5x150
PHILLIPS	1x150	2x175	-	-

**CÓDIGO**  
CODE / CODE / CÓDIGO

**EMBALAGEM**  
QUANTITY / EMBALLAGE / EMBALAJE

000011000234

1



## Chaves de Aperto

Wrenches / Clés de serrage / Llaves de Apriete

### Chave Magnética para Bit 1/4"

Magnetic bit holder for 1/4" bits / Porte-embouts magnétiques pour embouts 1/4"  
/ Portapuntas magnético para puntas 1/4"



**CÓDIGO**  
CODE / CODE / CÓDIGO  
000011000235

**EMBALAGEM**  
QUANTITY / EMBALLAGE / EMBALAJE  
1

### Conjunto 32 Bits 1/4"

1/4" Bits Sets, 32 Pcs / Jeu D'embouts 1/4", 32 Pièces / Juego 32 Puntas 1/4"



- x3
- x6
- x5
- x11
- x4

**CÓDIGO**  
CODE / CODE / CÓDIGO  
000011000236

**EMBALAGEM**  
QUANTITY / EMBALLAGE / EMBALAJE  
1

### Chave Hexagonal T com bola

T-handle with hexagonal tip / Tournevis avec manche en T, tête sphérique / Destornilladores mangos en T, Hexagonal Bola /

**DIMENSÕES (mm)**  
/ SIZE (mm) / DIMENSIONS (mm)  
/ MEDIDA (mm)

3 x 100 mm | 5 x 150 mm  
4 x 150 mm | 6 x 200 mm



**CÓDIGO**  
CODE / CODE / CÓDIGO

**DIMENSÕES**  
/ SIZE / DIMENSIONS / MEDIDA

**EMBALAGEM**  
QUANTITY / EMBALLAGE  
/ EMBALAJE

CÓDIGO CODE / CODE / CÓDIGO	DIMENSÕES / SIZE / DIMENSIONS / MEDIDA	EMBALAGEM QUANTITY / EMBALLAGE / EMBALAJE
000011000229	3 x 100 mm	1
000011000230	4 x 150 mm	1
000011000231	5 x 150 mm	1
000011000232	6 x 200 mm	1

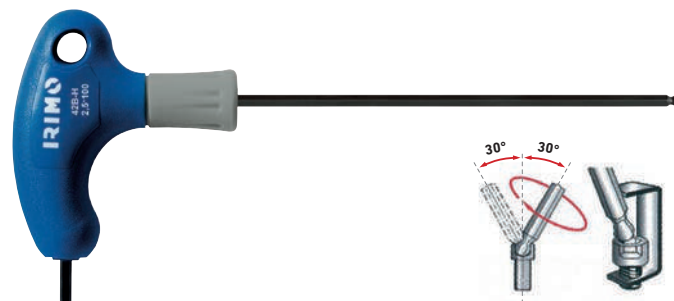

### Conjunto 9 Chaves Hexagonais C/ Bola

Set of long ball end hex keys, 9 pieces / Jeu de clés mâles  
longues à tête sphérique pour vis 6 pans, 9 pièces  
/ Juego llaves largas con bola

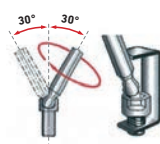

**DIMENSÕES / SIZE / DIMENSIONS / MEDIDA**

Ø 1,5	Ø 2	Ø 2,5	Ø 3	Ø 4	Ø 5	Ø 6	Ø 8	Ø 10
1 Uni.	1 Uni.	1 Uni.	1 Uni.	1 Uni.	1 Uni.	1 Uni.	1 Uni.	1 Uni.

**CÓDIGO**  
CODE / CODE / CÓDIGO

**DIMENSÕES**  
/ SIZE / DIMENSIONS / MEDIDA

**EMBALAGEM**  
QUANTITY / EMBALLAGE  
/ EMBALAJE

000011000238	1,5 mm x 10 mm	1
--------------	----------------	---

### Conjunto 9 Chaves Hexagonais

Set of black finish hex keys, 9 pieces / Jeu de clés brunies  
pour vis 6 pans, 9 pièces / Juego de 9 llaves hex pavonadas



**DIMENSÕES / SIZE / DIMENSIONS / MEDIDA**

Ø 1,5	Ø 2	Ø 2,5	Ø 3	Ø 4	Ø 5	Ø 6	Ø 8	Ø 10
1 Uni.	1 Uni.	1 Uni.	1 Uni.	1 Uni.	1 Uni.	1 Uni.	1 Uni.	1 Uni.

**CÓDIGO**  
CODE / CODE / CÓDIGO

**DIMENSÕES**  
/ SIZE / DIMENSIONS / MEDIDA

**EMBALAGEM**  
QUANTITY / EMBALLAGE  
/ EMBALAJE

000011000237	1,5 mm x 10 mm	1
--------------	----------------	---



# FERRAMENTA MANUAL

Hand Tools / Outillage Manuel / Herramienta Manual

## Chaves de Aperto

Wrenches / Clés de serrage / Llaves de Apriete

### Chave Combinada / Combination Wrenches / Clé Mixte / Llaves Combinadas



**DIMENSÕES (mm)**  
/ SIZE (mm) / DIMENSIONS (mm)  
/ MEDIDA (mm)  
8 - 10 - 11 - 13 - 14 - 17  
19 - 22 - 24 - 27 - 30 - 32

CÓDIGO CODE / CODE / CÓDIGO	DIMENSÕES / SIZE / DIMENSIONS / MEDIDA	EMBALAGEM QUANTITY / EMBALLAGE / EMBALAJE
000011000484	6	1
000011000485	7	1
000011000200	8	1
000011000486	9	1
000011000201	10	1
000011000202	11	1
000011000203	13	1
000011000204	14	1
000011000487	15	1
000011000488	16	1
000011000205	17	1
000011000492	18	1
000011000206	19	1

CÓDIGO CODE / CODE / CÓDIGO	DIMENSÕES / SIZE / DIMENSIONS / MEDIDA	EMBALAGEM QUANTITY / EMBALLAGE / EMBALAJE
000011000207	22	1
000011000493	23	1
000011000208	24	1
000011000209	27	1
000011000929	29	1
000011000210	30	1
000011000211	32	1
000011000603	34	1
000011000285	36	1
000011000930	41	1
000011000821	46	1
000011000931	50	1
000011000960	55	1

### Conjunto Chaves Combinadas / Combination Wrenche Set / Jeu de Clés Mixtes / Juego Llaves Combinadas

8 mm -> 22 mm



CÓDIGO CODE / CODE / CÓDIGO	DIMENSÕES / SIZE / DIMENSIONS / MEDIDA	EMBALAGEM QUANTITY / EMBALLAGE / EMBALAJE
000011000214	8-22mm	1

10 mm -> 32 mm



CÓDIGO CODE / CODE / CÓDIGO	DIMENSÕES / SIZE / DIMENSIONS / MEDIDA	EMBALAGEM QUANTITY / EMBALLAGE / EMBALAJE
000011000213	10-32mm	1





## Chaves de Aperto

Wrenches / Clés de serrage / Llaves de Apriete

### Chave Roquete 1/4" e 1/2"

1/4" and 1/2" Reversible ratchet / Cliquet Réversible 1/4" et 1/2" / Carraca Tipo Pera 1/4" y 1/2"



CÓDIGO CODE / CODE / CÓDIGO	DIMENSÕES / SIZE / DIMENSIONS / MEDIDA	EMBALAGEM QUANTITY / EMBALLAGE / EMBALAJE
000011000239	1/4"	1
000011000240	1/2"	1

### Chave Caixa 1/4" / 1/4" Sockets / Douille 1/4" / Vasos 1/4" HEX

**DIMENSÕES (mm)**  
/ SIZE (mm) / DIMENSIONS (mm)  
/ MEDIDA (mm)  
4 - 5 - 6 - 7 - 8 - 9  
10 - 11 - 12 - 13



**1/4"**  
6.3 mm

**1/2"**  
12.5 mm



**DIMENSÕES (mm)**  
/ SIZE (mm) / DIMENSIONS (mm)  
/ MEDIDA (mm)  
8 - 10 - 12 - 13 - 14  
16 - 17 - 19 - 20 - 22

CÓDIGO CODE / CODE / CÓDIGO	DIMENSÕES / SIZE / DIMENSIONS / MEDIDA	EMBALAGEM QUANTITY / EMBALLAGE / EMBALAJE
000011000251	4	1
000011000252	5	1
000011000253	6	1
000011000254	7	1
000011000255	8	1
000011000256	9	1
000011000257	10	1
000011000258	11	1
000011000259	12	1
000011000260	13	1

CÓDIGO CODE / CODE / CÓDIGO	DIMENSÕES / SIZE / DIMENSIONS / MEDIDA	EMBALAGEM QUANTITY / EMBALLAGE / EMBALAJE
000011000270	8	1
000011000271	10	1
000011000272	12	1
000011000273	13	1
000011000274	14	1
000011000275	16	1
000011000276	17	1
000011000277	19	1
000011000278	20	1
000011000279	22	1

### Chave Impacto 1/2" / 1/2" Impact sockets / Douille à chocs 1/2" / Vasos impacto 1/2" HEX

**DIMENSÕES (mm)**  
/ SIZE (mm) / DIMENSIONS (mm)  
/ MEDIDA (mm)  
8 - 10 - 12 - 13 - 14 - 16 -  
17 19 - 20 - 24 - 30 - 34 - 36



**1/2"**  
12.5 mm

**3/4"**  
20 mm



**DIMENSÕES (mm)**  
/ SIZE (mm) / DIMENSIONS (mm)  
/ MEDIDA (mm)  
24 - 27 - 29 - 30  
32 - 34 - 36 - 38

CÓDIGO CODE / CODE / CÓDIGO	DIMENSÕES / SIZE / DIMENSIONS / MEDIDA	EMBALAGEM QUANTITY / EMBALLAGE / EMBALAJE
000011000302	8	1
000011000303	10	1
000011000304	12	1
000011000305	13	1
000011000306	14	1
000011000307	16	1
000011000308	17	1
000011000309	19	1
000011000310	20	1
000011000312	24	1
000011000313	30	1
000011000314	34	1
000011000315	36	1

CÓDIGO CODE / CODE / CÓDIGO	DIMENSÕES / SIZE / DIMENSIONS / MEDIDA	EMBALAGEM QUANTITY / EMBALLAGE / EMBALAJE
000011000320	24	1
000011000321	27	1
000011000322	29	1
000011000323	30	1
000011000324	32	1
000011000325	34	1
000011000326	36	1
000011000327	38	1

### Amplificador / Increasing adaptor / Augmentateur / Ampliador

#### Amplificador 1/2" -> 3/4"

CÓDIGO CODE / CODE / CÓDIGO	EMBALAGEM QUANTITY / EMBALLAGE / EMBALAJE
000011000311	1



### Redutor / Réducteur / Reducing adaptor / Redutor

#### Redutor 3/4" -> 1/2"

CÓDIGO CODE / CODE / CÓDIGO	EMBALAGEM QUANTITY / EMBALLAGE / EMBALAJE
000011000330	1





# FERRAMENTA MANUAL

Hand Tools / Outillage Manuel / Herramienta Manual

## Chaves de Aperto

Wrenches / Clés de serrage / Llaves de Apriete

Conjunto Chaves Roquete / Socket Set / Jeu de Douilles / Juego Vasos

CONJUNTO CHAVES ROQUETE / Socket Set / Jeu de Douilles / Juego Vasos

35 PEÇAS / Pcs / Pièces / Piezas

1/4"  
6.3 mm



CÓDIGO  
CODE / CODE / CÓDIGO

000011000241

EMBALAGEM  
QUANTITY / EMBALLAGE / EMBALAJE

1

CONJUNTO CHAVES ROQUETE / Socket Set / Jeu de Douilles / Juego Vasos

23 PEÇAS / Pcs / Pièces / Piezas

1/2"  
12.5 mm



CÓDIGO  
CODE / CODE / CÓDIGO

000011000242

EMBALAGEM  
QUANTITY / EMBALLAGE / EMBALAJE

1

CONJUNTO CHAVES ROQUETE / Socket Set / Jeu de Douilles / Juego Vasos

101 PEÇAS / Pcs / Pièces / Piezas

1/2"  
12.5 mm

1/4"  
6.3 mm



CÓDIGO  
CODE / CODE / CÓDIGO

000011000243

EMBALAGEM  
QUANTITY / EMBALLAGE / EMBALAJE

1



## Chaves de Aperto

Wrenches / Clés de serrage / Llaves de Apriete

### Chave Inglesa 10"

Adjustable Wrenches / Clés à Molette / Llaves Ajustable



CÓDIGO CODE / CODE / CÓDIGO	DIMENSÕES / SIZE / DIMENSIONS / MEDIDA	EMBALAGEM QUANTITY / EMBALLAGE / EMBALAJE
000011000212	250	1

## Martelos

Mallets and Hammers / Masse et marteau / Mazos y Martillos

### Martelo Orelhas

/ Curved Claw Hammer / Marteau a Panne Fendue / Martillo de Carpintero



### Martelo Pena

/ German DIN Hammer / Marteau de Serrurier / Martillo para Mecánico tipo Alemán DIN



CÓDIGO CODE / CODE / CÓDIGO	PESO / WEIGHT / POIDS / PESO		EMBALAGEM QUANTITY / EMBALLAGE / EMBALAJE
	g	OZ	
000011000244	460	16	1

CÓDIGO CODE / CODE / CÓDIGO	PESO / WEIGHT / POIDS / PESO		EMBALAGEM QUANTITY / EMBALLAGE / EMBALAJE
	g	OZ	
000011000246	500	-	1

### Martelo Bola

/ Ball Pein Hammer / Marteau de Serrurier / Martillo de Bola



### Maço Anti Ressonância

/ Anti-Bounce Nylon Faced Hammers / Marteau à Tête en Nylon Anti-Rebond / Martillo Antirrebote



CÓDIGO CODE / CODE / CÓDIGO	PESO / WEIGHT / POIDS / PESO		EMBALAGEM QUANTITY / EMBALLAGE / EMBALAJE
	g / OZ	MM	
000011000245	460 / 16	-	1

CÓDIGO CODE / CODE / CÓDIGO	PESO / WEIGHT / POIDS / PESO		EMBALAGEM QUANTITY / EMBALLAGE / EMBALAJE
	g / OZ	OZ	
000011000331	-	35	1



# FERRAMENTA MANUAL

Hand Tools / Outillage Manuel / Herramienta Manual

## Alicates

Pliers / Pincas / Alicates

### Alicate Universal

Combination Pliers / Pince Universelle / Alicate Universal



CÓDIGO CODE / CODE / CÓDIGO	DIMENSÕES / SIZE / DIMENSIONS / MEDIDA	EMBALAGEM QUANTITY / EMBALLAGE / EMBALAJE
000011000215	180	1
000011000216	200	1

### Alicate Pontas Redondas

Snipe Nose Pliers / Pince à Becs Demi-Ronds / Alicate Boca Semirredonda



CÓDIGO CODE / CODE / CÓDIGO	DIMENSÕES / SIZE / DIMENSIONS / MEDIDA	EMBALAGEM QUANTITY / EMBALLAGE / EMBALAJE
000011000219	200	1

### Alicate Corte

Side Cutting Pliers / Pince Coupante Diagonale / Alicate Cortante



CÓDIGO CODE / CODE / CÓDIGO	DIMENSÕES / SIZE / DIMENSIONS / MEDIDA	EMBALAGEM QUANTITY / EMBALLAGE / EMBALAJE
000011000217	160	1

### Alicate Corte Reforçado

Side Cutting Pliers / Pince Coupante Diagonale / Alicate Cortante Reforçado



CÓDIGO CODE / CODE / CÓDIGO	DIMENSÕES / SIZE / DIMENSIONS / MEDIDA	EMBALAGEM QUANTITY / EMBALLAGE / EMBALAJE
000011000218	180	1

### Alicate Universal VDE

Insulated Combination Pliers / Pince Universelle Isolée / Alicate Universal Aislado



CÓDIGO CODE CODE CÓDIGO	DIMENSÕES SIZE DIMENSIONS MEDIDA	EMBALAGEM QUANTITY EMBALLAGE EMBALAJE
000011000587	200	1

### Alicate Pontas Redondas VDE

Snipe Nose Pliers Insulated / Pince à Becs Demi-Ronds Isolée / Alicate Boca Semirredonda Aislado



CÓDIGO CODE CODE CÓDIGO	DIMENSÕES SIZE DIMENSIONS MEDIDA	EMBALAGEM QUANTITY EMBALLAGE EMBALAJE
000011000290	200	1

### Alicate Corte VDE

Insulated Side Cutting Pliers / Pince coupante diagonale isolée / Alicate Cortante Aislado



CÓDIGO CODE CODE CÓDIGO	DIMENSÕES SIZE DIMENSIONS MEDIDA	EMBALAGEM QUANTITY EMBALLAGE EMBALAJE
000011000667	160	1

### Alicate Descarnar VDE

Insulated Stripping Pliers / Pince à dénuder isolée / Alicate Pelacables Aislado



CÓDIGO CODE CODE CÓDIGO	DIMENSÕES SIZE DIMENSIONS MEDIDA	EMBALAGEM QUANTITY EMBALLAGE EMBALAJE
000011000413	160	1

### Conjunto Alicates / Pliers Sets / Jeu de pinces / Juego Alicates

3 Peças / Pcs / Pièces / Piezas

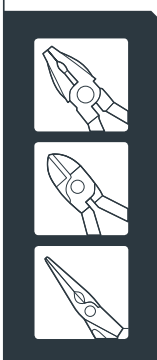

CÓDIGO CODE / CODE / CÓDIGO	DIMENSÕES / SIZE / DIMENSIONS / MEDIDA	EMBALAGEM QUANTITY / EMBALLAGE / EMBALAJE
000011000221	160 / 180 / 200	1

### Conjunto Alicates VDE / Pliers Sets VDE / Jeu de Pincas VDE / Juego 3 Alicates VDE

3 Peças / Pcs / Pièces / Piezas

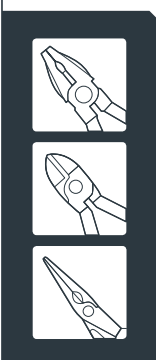

CÓDIGO CODE / CODE / CÓDIGO	DIMENSÕES / SIZE / DIMENSIONS / MEDIDA	EMBALAGEM QUANTITY / EMBALLAGE / EMBALAJE
000011000222	160 / 180 / 200	1



## Alicates

Pliers / Pinces / Alicates

### Alicate Pressão

Curved Jaws with Cutter / Becs Coudés avec Coupe-Fil / Bocas Curvas y Cortante



CÓDIGO CODE / CODE / CÓDIGO	DIMENSÕES / SIZE / DIMENSIONS / MEDIDA	EMBALAGEM QUANTITY / EMBALLAGE / EMBALAJE
000011000223	180	1
000011000366	250	1

### Alicate Canalizador

Slip Joint Pliers / Pince Multiprises / Tenacilla Ajuste Rápido



CÓDIGO CODE / CODE / CÓDIGO	DIMENSÕES / SIZE / DIMENSIONS / MEDIDA	EMBALAGEM QUANTITY / EMBALLAGE / EMBALAJE
000011000707	200	1
000011000220	250	1
000011000645	300	1

### Alicate Pressão "Pescoco Cisne"

C Clamp / C à Col de Cygne / Mordaza Grip con Sujeción C

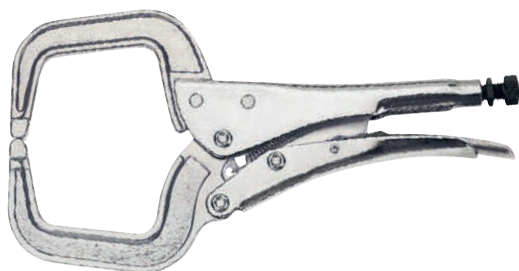

CÓDIGO CODE / CODE / CÓDIGO	DIMENSÕES / SIZE / DIMENSIONS / MEDIDA	EMBALAGEM QUANTITY / EMBALLAGE / EMBALAJE
000011000225	280	1

### Alicate Pressão para Soldadura "U"

U Clamp / Pince-Etau en Forme de U / Mordaza Grip para Soldadura Tipo "U"



CÓDIGO CODE / CODE / CÓDIGO	DIMENSÕES / SIZE / DIMENSIONS / MEDIDA	EMBALAGEM QUANTITY / EMBALLAGE / EMBALAJE
000011000224	290	1

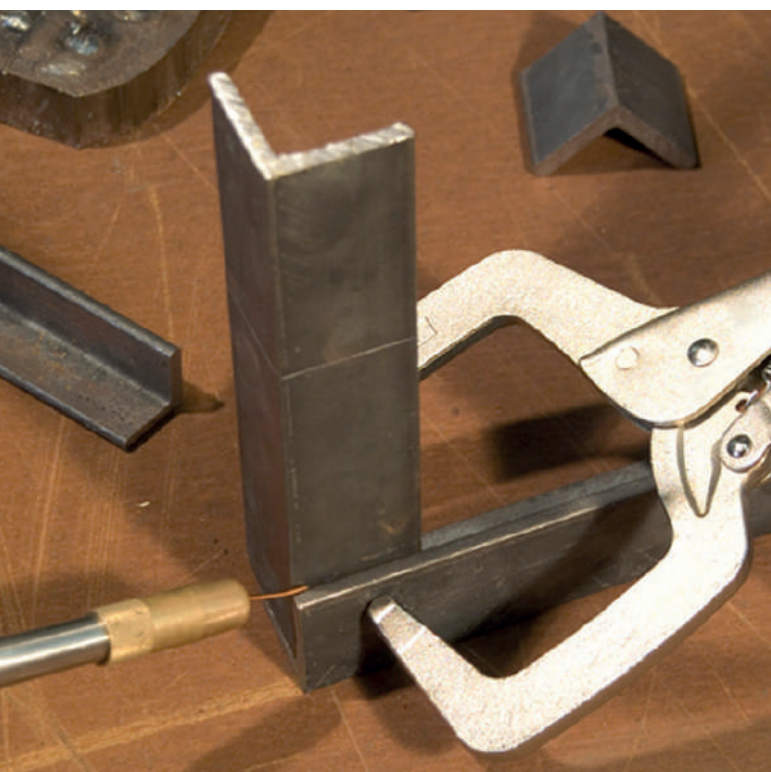

## Torno

Square Guide Bench Vice / Etau à guide carré / Tornillo Banco Guía Cuadrada



CÓDIGO CODE / CODE / CÓDIGO	DIMENSÕES / SIZE / DIMENSIONS / MEDIDA	EMBALAGEM QUANTITY / EMBALLAGE / EMBALAJE
000011000299	125	1



# FERRAMENTA MANUAL

Hand Tools / Outillage Manuel / Herramienta Manual

## Armazenamento de Ferramentas

Tool Storage / Rangement Outils / Almacenamiento de Herramientas

### Carro de Ferramentas / Tool trolleys / Servantes / Carros

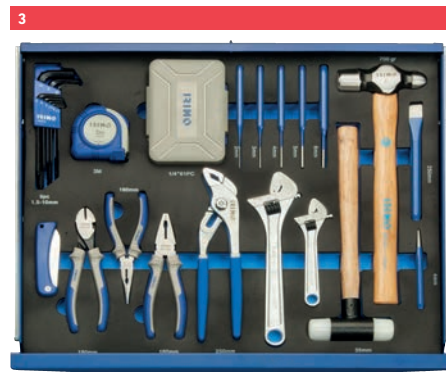
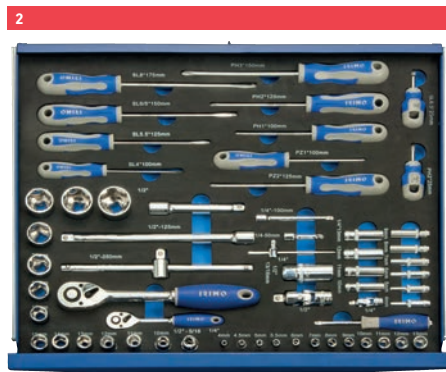
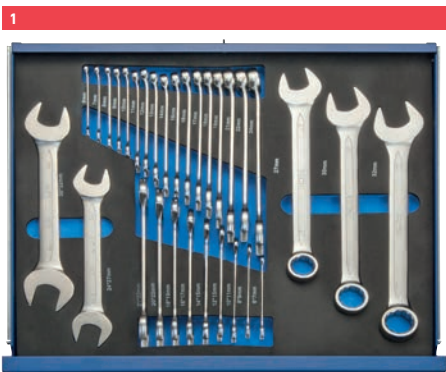

**CÓDIGO**  
CODE / CODE / CÓDIGO  
000011000300

**EMBALAGEM**  
QUANTITY / EMBALLAGE / EMBALAJE  
1



**Ideal para manutenção industrial | Serralharias | Indústria automóvel**  
Appropriate for industrial maintenance | Metal Industry | Vehicle Industry  
Idéal pour la maintenance industrielle | Serrurerie | l'industrie automobile  
Ideal para el mantenimiento industrial | Carpintería de Hierro | Industria de Automoción

### Mala de Ferramentas em Alumínio com 97 Peças / Aluminium tool case with 97 tools / Malette 97 outils en Aluminium / Caja rígida de 97 herramientas de Aluminio



**CÓDIGO**  
CODE / CODE / CÓDIGO  
000011000301

**COR**  
COLOR / COULEUR / COLOR  
Cinza / Grey / Gris / Gris

**EMBALAGEM**  
QUANTITY / EMBALLAGE / EMBALAJE  
1



**Ideal para manutenção industrial | Produção de aço ou alumínio | Indústria automóvel**  
Appropriate for industrial maintenance | Steel or aluminum production | Vehicle Industry  
Idéal pour la maintenance industrielle | production d'acier ou d'aluminium | l'industrie automobile  
Ideal para el mantenimiento industrial | Producción de acero o aluminio | Industria de Automoción







**1 DESBLOQUEIE A CHAVE DINAMOMÉTRICA**  
/ Unlock the torque wrench  
/ Débloquer la clé dynamométrique  
/ Desbloquee la llave dinamométrica

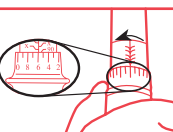

**2 AJUSTE O LIMITE DE APERTO**  
/ Adjust the requested torque  
/ Ajuster le limite de serrage  
/ Ajuste el límite de apriete



**3 ALINHE A ESCALA**  
/ Align correctly the scale  
/ Aligner à l'échelle  
/ Alinee la escala



**4 BLOQUEIE O LIMITE DE APERTO**  
/ Lock the torque wrench  
/ Bloquer le limite de serrage  
/ Bloquee el límite de aprietela escala

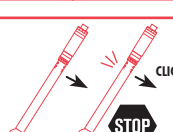

**5 PARE QUANDO OUVIR UM "CLIQUE"**  
/ Stop when hear a "click"  
/ Arrêter après entendre un "clique"  
/ Pare cuando escuche un "click"

CÓDIGO / CODE / CODE / CÓDIGO	ENCAIXE / FITTING / AJUSTEMENT / ENCAJE	TORQUE (Nm) / TORQUE (Nm) / TORQUE (Nm) / TORQUE (Nm)	COMPRIMENTO (mm) / LENGTH (mm) / LONGUEUR (mm) / LARGO (mm)	PESO (gr) / WEIGHT / POIDS / PESO	EMBALAGEM QUANTITY / EMBALLAGE / EMBALAJE
000011000475	1/2"	25 - 125	420	0,9	1
000011000979	1/2"	40 - 200	460	1,0	1
000011000808	1/2"	65 - 335	520	1,2	1
000011000736	1/4"	4 - 20	275	0,5	1

**Para aperto de parafusos hexagonais, em todos os setores industriais | Ideal para construção estrutural de metal**  
Main sectors of industry, specially all users of hexagonal screws | Useful for metallic structure assembling  
Pour le serrage de vis hexagonales, dans tous les secteurs industriels | Idéale pour construction structurelle de métal  
Para apriete de tornillos hexagonales, en todos los sectores industriales | Ideal para construcción estructural de metal

## Chave Dinamométrica

Torque Wrench / Clé Dynamométrique / Llave Dinamométrica



## Chave para Aperto de Varão Roscado

Hollow Shaft Nut Driver / Tournevis à douille aimanté HollowCore / Destornillador de Vaso Magnético Hollowcore



CÓDIGO / CODE / CODE / CÓDIGO	COR / COLOR / COULEUR / COLOR	VÁLIDO PARA SUITABLE FOR / VALABLE POUR / VÁLIDO PARA	EMBALAGEM QUANTITY / EMBALLAGE / EMBALAJE
		Varão ou haste rosçada Threaded rod or Stud bolt / Tige fileté ou Bouts filetés / Varrilla rosçada o esparrago rosçada	
Sob consulta	M3	Ø 5,5 mm	1
Sob consulta	M3,5	Ø 6 mm	1
Sob consulta	M4	Ø 7 mm	1
Sob consulta	M5	Ø 8 mm	1
001190222533	M6	Ø 10 mm	1
001190222535	M8	Ø 13 mm	1

**Construção com interior oco permite e facilita o aperto de porcas em varões e hastes rosçadas**  
The hollow core is ideal for long bolts for threaded rod applications  
Sa construction avec un intérieur creux permet et facilite le serrage d'écrous en tiges filetés  
Construcción con interior hueco que permite y facilita el apriete de tuercas en barras y varillas rosçadas





# FERRAMENTA MANUAL

Hand Tools / Outillage Manuel / Herramienta Manual

## BITS

### Bits Premium e Special

Bits Premium and Special / Embouts Premium et Special / Puntas Premium y Special

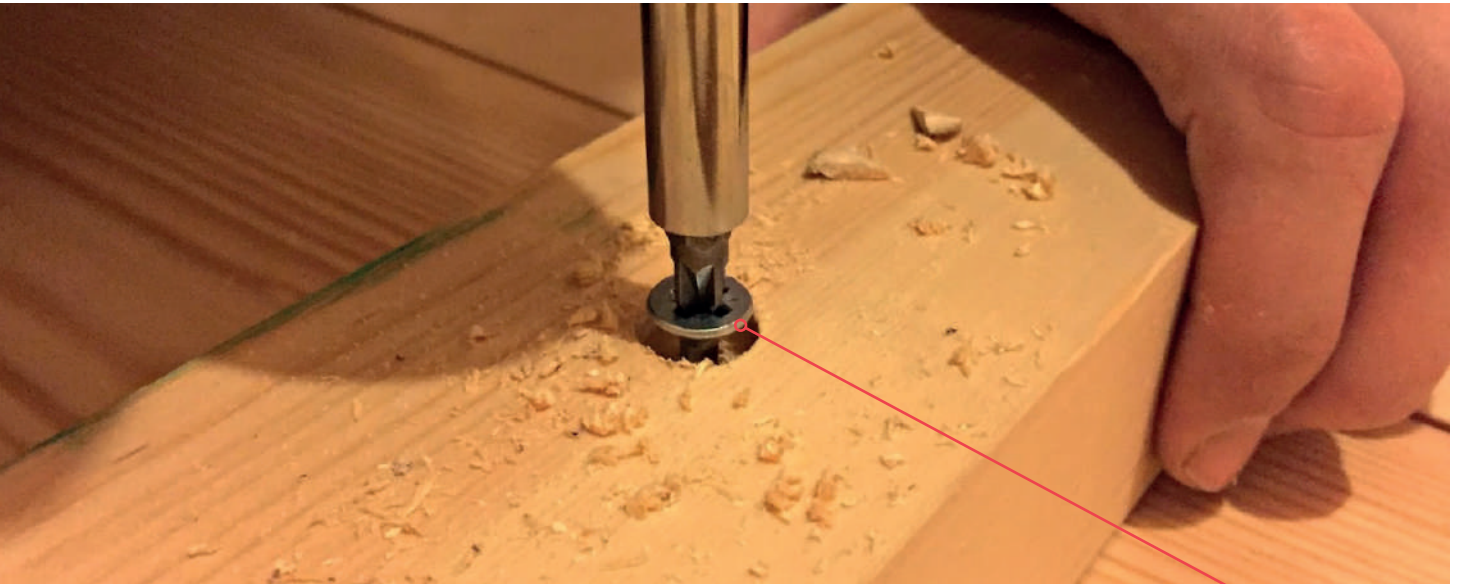

Phillips / Phillips / Phillips / Phillips



Pozidrive / Pozidriv / Pozidriv / Pozidriv



Phillips / Phillips / Phillips / Phillips



Pozidrive / Pozidriv / Pozidriv / Pozidriv



Fenda / Slotted / Fente / Plana



Torx / Torx / Torx / Torx



Fenda Quadrada / Squared / Empreinte Carrée / Cuadrada



Hexagonal / Hexagonal / Hexagonale / Hexagonal







Phillips / Phillips / Phillips / Phillips

**BIT PREMIUM**

CÓDIGO CODE / CODE / CÓDIGO	HASTE SHANK / TIGE / HEXÁGONO	COMPRIMENTO LENGTH / LONGUEUR / LONGITUD		EMBALAGEM QUANTITY / EMBALLAGE / EMBALAJE
000821010251	¼"	25	PH1	5
000821020252	¼"	25	PH2	5



**Todos os setores industriais | Indústria de caixilharia | Fabrico de móveis | Indústria metalomecânica**  
Main sectors of industry | Window frame industry | Furniture manufacture | Metal industry  
Tous les secteurs industriels | Industrie de charpente | Fabrication de meubles | Industrie métallo-mécanique  
Todos los sectores industriales | Industria de armazones | Fabricación de muebles | Industria metalmeccánica

Pozidriv / Pozidriv / Pozidriv / Pozidrive

**BIT PREMIUM**

CÓDIGO CODE / CODE / CÓDIGO	HASTE SHANK / TIGE / HEXÁGONO	COMPRIMENTO LENGTH / LONGUEUR / LONGITUD		EMBALAGEM QUANTITY / EMBALLAGE / EMBALAJE
000831010251	¼"	25	PZ1	5
000831020252	¼"	25	PZ2	5



**Todos os setores industriais | Indústria de caixilharia | Fabrico de móveis | Indústria metalomecânica**  
Main sectors of industry | Window frame industry | Furniture manufacture | Metal industry  
Tous les secteurs industriels | Industrie de charpente | Fabrication de meubles | Industrie métallo-mécanique  
Todos los sectores industriales | Industria de armazones | Fabricación de muebles | Industria metalmeccánica

Phillips / Phillips / Phillips / Phillips

**BIT SPECIAL**

CÓDIGO CODE / CODE / CÓDIGO	HASTE SHANK / TIGE / HEXÁGONO	COMPRIMENTO LENGTH / LONGUEUR / LONGITUD		EMBALAGEM QUANTITY / EMBALLAGE / EMBALAJE
000821010250	¼"	25	PH1	10
000821020250	¼"	25	PH2	10
000821030250	¼"	25	PH3	10
000821010500	¼"	50	PH1	10
000821020500	¼"	50	PH2	10
000821030500	¼"	50	PH3	10
000821010750	¼"	75	PH1	5
000821020750	¼"	75	PH2	5
000821030750	¼"	75	PH3	5
000821020900	¼"	90	PH2	5



**Todos os setores industriais | Indústria de caixilharia | Fabrico de móveis | Indústria metalomecânica**  
Main sectors of industry | Window frame industry | Furniture manufacture | Metal industry  
Tous les secteurs industriels | Industrie de charpente | Fabrication de meubles | Industrie métallo-mécanique  
Todos los sectores industriales | Industria de armazones | Fabricación de muebles | Industria metalmeccánica

Pozidriv / Pozidriv / Pozidriv / Pozidrive

**BIT SPECIAL**

CÓDIGO CODE / CODE / CÓDIGO	HASTE SHANK / TIGE / HEXÁGONO	COMPRIMENTO LENGTH / LONGUEUR / LONGITUD		EMBALAGEM QUANTITY / EMBALLAGE / EMBALAJE
000831010250	¼"	25	PZ1	10
000831020250	¼"	25	PZ2	10
000831030250	¼"	25	PZ3	10
000831010500	¼"	50	PZ1	10
000831020500	¼"	50	PZ2	10
000831030500	¼"	50	PZ3	10
000831010750	¼"	75	PZ1	5
000831020750	¼"	75	PZ2	5
000831030750	¼"	75	PZ3	5



**Todos os setores industriais | Indústria de caixilharia | Fabrico de móveis | Indústria metalomecânica**  
Main sectors of industry | Window frame industry | Furniture manufacture | Metal industry  
Tous les secteurs industriels | Industrie de charpente | Fabrication de meubles | Industrie métallo-mécanique  
Todos los sectores industriales | Industria de armazones | Fabricación de muebles | Industria metalmeccánica



# FERRAMENTA MANUAL

Hand Tools / Outillage Manuel / Herramienta Manual

## BIT SPECIAL

Fenda / Slotted / Fente / Plana



CÓDIGO CODE / CODE / CÓDIGO	HASTE SHANK / TIGE / HEXÁGONO	COMPRIMENTO LENGTH / LONGUEUR / LONGITUD	Ø	ESPESSURA THICKNESS / ÉPAISSEUR / ESPEJOR	EMBALAGEM QUANTITY / EMBALLAGE / EMBALAJE
000811040525	¼"	25	4.0	0.5	10
000811450525	¼"	25	4.5	0.6	10
000811550825	¼"	25	5.5	0.8	10
000811651225	¼"	25	6.5	1.2	10
000811400550	¼"	50	4.0	0.5	10
000811450650	¼"	50	4.5	0.6	10
000811550850	¼"	50	5.5	0.8	10
000811651250	¼"	50	6.5	1.2	10
000811400575	¼"	75	4.0	0.5	5
000811450675	¼"	75	4.5	0.6	5
000811550875	¼"	75	5.5	0.8	5
000811651275	¼"	75	6.5	1.2	5
000811400510	¼"	100	4.0	0.5	5
000811450610	¼"	100	4.5	0.6	5
000811550810	¼"	100	5.5	0.8	5
000811651210	¼"	100	6.5	1.2	5



Todos os setores industriais | Indústria de caixilharia | Fabrico de móveis | Indústria metalomecânica

Main sectors of industry | Window frame industry | Furniture manufacture | Metal industry

Tous les secteurs industriels | Industrie de charpente | Fabrication de meubles | Industrie métallo-mécanique

Todos los sectores industriales | Industria de armazones | Fabricación de muebles | Industria metalmeccánica

## BIT SPECIAL

Torx / Torx / Torx / Torx



CÓDIGO CODE / CODE / CÓDIGO	HASTE SHANK / TIGE / HEXÁGONO	COMPRIMENTO LENGTH / LONGUEUR / LONGITUD	EMBALAGEM QUANTITY / EMBALLAGE / EMBALAJE
000841008000	¼"	25	TX8 10
000841010000	¼"	25	TX10 10
000841015000	¼"	25	TX15 10
000841020000	¼"	25	TX20 10
000841025000	¼"	25	TX25 10
000841027000	¼"	25	TX27 10
000841030000	¼"	25	TX30 10
000841040000	¼"	25	TX40 10
000841025002	¼"	50	TX25 10
000841025001	¼"	70	TX25 10



Todos os setores industriais | Indústria de caixilharia | Fabrico de móveis | Indústria metalomecânica

Main sectors of industry | Window frame industry | Furniture manufacture | Metal industry

Tous les secteurs industriels | Industrie de charpente | Fabrication de meubles | Industrie métallo-mécanique

Todos los sectores industriales | Industria de armazones | Fabricación de muebles | Industria metalmeccánica

## BIT SPECIAL

Hexagonal / Hexagonal / Hexagonale / Hexagonal



CÓDIGO CODE / CODE / CÓDIGO	HASTE SHANK / TIGE / HEXÁGONO	COMPRIMENTO LENGTH / LONGUEUR / LONGITUD	Ø	EMBALAGEM QUANTITY / EMBALLAGE / EMBALAJE
000863025200	¼"	25	2	10
000863025250	¼"	25	2.5	10
000863030250	¼"	25	3	10
000863040250	¼"	25	4	10
000863050250	¼"	25	5	10
000863060250	¼"	25	6	10
000863080250	¼"	25	8	10
000863025500	¼"	50	2.5	10
000863030500	¼"	50	3	10
000863040500	¼"	50	4	10
000863050500	¼"	50	5	10
000863060500	¼"	50	6	10
000863080500	¼"	50	8	10



Todos os setores industriais | Indústria de caixilharia | Fabrico de móveis | Indústria metalomecânica

Main sectors of industry | Window frame industry | Furniture manufacture | Metal industry

Tous les secteurs industriels | Industrie de charpente | Fabrication de meubles | Industrie métallo-mécanique

Todos los sectores industriales | Industria de armazones | Fabricación de muebles | Industria metalmeccánica



CÓDIGO CODE / CODE / CÓDIGO	HASTE SHANK / TIGE / HEXÁGONO	COMPRIMENTO LENGTH / LONGUEUR / LONGITUD		EMBALAGEM QUANTITY / EMBALLAGE / EMBALAJE
000850010250	¼"	25	FQ1	10
000851010250	¼"	25	FQ2	10
000851030250	¼"	25	FQ3	10
000850010500	¼"	50	FQ1	10
000851020500	¼"	50	FQ2	10
000851030500	¼"	50	FQ3	10



Todos os setores industriais | Indústria de caixilharia | Fabrico de móveis | Indústria metalomecânica  
Main sectors of industry | Window frame industry | Furniture manufacture | Metal industry  
Tous les secteurs industriels | Industrie de charpente | Fabrication de meubles | Industrie métallo-mécanique  
Todos los sectores industriales | Industria de armazones | Fabricación de muebles | Industria metalmeccánica



**BIT vs FENDA**

BIT vs SLOT / EMBOUT vs FENTE / PUNTA vs PLANA



**Parafuso rosca métrica**

Metric thread screws / Vis filetage métrique / Tornillos Rosca Métrica



Ø	Ø
M3	P3
M4	P4
M5	P5
M6	P6



Ø	Ø
M2	PH1
M3	PH1
M4	PH2
M5	PH2
M6	PH3
M8	PH3
M10	PH3



Ø	Ø
M2	PZ1
M3	PZ1
M4	PZ2
M5	PZ2
M6	PZ3
M8	PZ3
M10	PZ3



Ø	Ø
M3	TX10
M4	TX20
M5	TX25
M6	TX30

**Parafuso rosca de chapa e madeira**

Self tapping and wood screw / Vis à tôle et à bois / Tornillería rosca chapa y Madera



Ø	Ø
2,9 mm	P3
3,5 mm	P3,5
3,9 mm	P4
4,2 mm	P4
4,8 mm	P5
5,5 mm	P6
6,3 mm	P6



Ø	Ø
2,9 mm	PH1
3,5 mm	PH2
3,9 mm	PH2
4,2 mm	PH2
4,8 mm	PH2
5,5 mm	PH3
6,3 mm	PH3



Ø	Ø
2,4 mm	PZ1
2,6 mm	PZ1
3,0 mm	PZ1
3,5 mm	PZ2
4,0 mm	PZ2
4,5 mm	PZ2
5,0 mm	PZ2
6,0 mm	PZ3



Ø	Ø
3,5 mm	TX15
4,2 mm	TX20
4,8 mm	TX25
5,5 mm	TX25
6,3 mm	TX30



Ø	Ø
4,2 mm	FQ2
4,8 mm	FQ2
5,5 mm	FQ2
6,3 mm	FQ3



# FERRAMENTA MANUAL

Hand Tools / Outillage Manuel / Herramienta Manual

## Conjunto de Bits 80 uni

Bits set 80 uni / Jeu d'Embouts 80 unités / Conjunto de Bits 80 uni



CÓDIGO CODE / CODE / CÓDIGO	TIPO DE PONTEIRA HEAD TYPE / TYPE DE POINTE / TIPO DE PUNTA	QUANTIDADE / QUANTITY / QUANTITÉ / CANTIDAD		EMBALAGEM QUANTITY / EMBALLAGE / EMBALAJE
		25 MM		
000821000001	PHILLIPS	PH1	20	1
	PHILLIPS / PHILLIPS / PHILLIPS	PH2	30	
		PH3	10	
	POZIDRIVE	PZ1	10	
		POZIDRIVE / POZIDRIVE / POZIDRIVE	PZ2	



Caixa com 80 Bits e 8 compartimentos, perfeito para utilização em armazéns/lojas

Box with 80 Bits with 8 compartments, ideal for storage and/or shop usage

Boîte com 80 Bits et 8 compartiments, parfait pour utilisation en entrepôts/boutiques

Caja con 80 Bits y 8 compartimentos, perfecto para utilización en almacenes/tiendas

## ADAPTADORES

Holders / Adaptateurs / Adaptadores

### Adaptador Magnético 1/4"

Magnetic Holders 1/4" / Porte-Embouts et Adaptateurs Magnétiques 1/4" / Llaves y Adaptadores Magnéticos 1/4"

#### CHAVE MAG. BITS

Aço / Steel / Acier / Acero



CÓDIGO CODE / CODE / CÓDIGO	ENCAIXE CONNECTION / INSERTION / INSERCIÓN	COMPRIMENTO LENGTH / LONGUEUR / LARGO	EMBALAGEM QUANTITY / EMBALLAGE / EMBALAJE
000871075000	1/4"	75	1



Todos os setores industriais | Indústria de caixilharia | Fabrico de móveis | Indústria metalomecânica

Main sectors of industry | Window frame industry | Furniture manufacture | Metal industry

Tous les secteurs industriels | Industrie de charpente | Fabrication de meubles | Industrie métal-mécanique

Todos los sectores industriales | Industria de armazones | Fabricación de muebles | Industria metalmeccánica

#### CHAVE MAG. BITS

Aço inox / Stainless steel / Inoxydable / Inoxidable



CÓDIGO CODE / CODE / CÓDIGO	ENCAIXE CONNECTION / INSERTION / INSERCIÓN	COMPRIMENTO LENGTH / LONGUEUR / LARGO	Ø	EMBALAGEM QUANTITY / EMBALLAGE / EMBALAJE
000871075001	1/4"	75	11	1
000871100000	1/4"	100	9.6	1



Todos os setores industriais | Indústria de caixilharia | Fabrico de móveis | Indústria metalomecânica

Main sectors of industry | Window frame industry | Furniture manufacture | Metal industry

Tous les secteurs industriels | Industrie de charpente | Fabrication de meubles | Industrie métal-mécanique

Todos los sectores industriales | Industria de armazones | Fabricación de muebles | Industria metalmeccánica

#### CHAVE MAG. BITS

SDS Plus / SDS Plus / SDS Plus / SDS Plus



CÓDIGO CODE / CODE / CÓDIGO	ENCAIXE CONNECTION / INSERTION / INSERCIÓN	COMPRIMENTO LENGTH / LONGUEUR / LARGO	EMBALAGEM QUANTITY / EMBALLAGE / EMBALAJE
000871080000	1/4"	80	1



Todos os setores industriais | Indústria de caixilharia | Fabrico de móveis | Indústria metalomecânica

Main sectors of industry | Window frame industry | Furniture manufacture | Metal industry

Tous les secteurs industriels | Industrie de charpente | Fabrication de meubles | Industrie métal-mécanique

Todos los sectores industriales | Industria de armazones | Fabricación de muebles | Industria metalmeccánica



## Chave Magnética

Hexagonal magnetic nut setter / Porte-Embout Magnétique / Boca Hexagonal Magnética

CÓDIGO CODE / CODE / CÓDIGO	ENCAIXE CONNECTION / INSERTION / INSERCIÓN	DIMENSÕES SIZE / DIMENSIONS / MEDIDA	EMBALAGEM QUANTITY / EMBALLAGE / EMBALAJE
000861007000	¼"	7	1
000861008000	¼"	8	1
000861010000	¼"	10	1
000861010110	¼"	11	1
000861013000	¼"	13	1



**Todos os setores industriais | Indústria de caixilharia | Fabrico de móveis | Indústria metalomecânica**  
Main sectors of industry | Window frame industry | Furniture manufacture | Metal industry  
Tous les secteurs industriels | Industrie de charpente | Fabrication de meubles | Industrie métallo-mécanique  
Todos los sectores industriales | Industria de armazones | Fabricación de muebles | Industria metalmeccánica

## Fita Métrica

Measuring Tapes / Mètre à Ruban / Cinta Métrica

Rubberized Measuring Tape / Mètre à ruban avec corps en caoutchouc / Cinta métrica con cuerpo de goma / Fita métrica com corpo de borracha

CÓDIGO CODE / CODE / CÓDIGO	DIMENSÕES DA FITA TAPE DIMENSIONS / DIMENSIONS DU RUBAN / DIMENSIONES DE LA CINTA	DIMENSÕES DA CAIXA CASE DIMENSIONS / DIMENSIONS DE LA BOITE / DIMENSIONES DE LA CAJA	EMBALAGEM QUANTITY / EMBALLAGE / EMBALAJE
000082910001	3 mt x 16 mm	60 mm x 60 mm x 25 mm	12
000082910002	5 mt x 25 mm	70 mm x 70 mm x 35 mm	12
000082910003	8 mt x 25 mm	80 mm x 80 mm x 45 mm	12



**Corpo em borracha injetada | Sem fixador magnético | Classe de medição II | Maior resistência e durabilidade**  
Rubberized case | Non magnetic hook | EC II class accuracy | Aging and wearing resistance  
Corps en caoutchouc injecté | Sans fixateur magnétique | Classe de mesure II | Plus grande résistance et durabilité  
Cuerpo en goma inyectada | Sin fijador magnético | Clase de medición II | Mayor resistencia y durabilidad



Measure Tape Self Lock / Mètre à Ruban autobloquant / Cinta Métrica Self Lock / Fita Métrica Self Lock

CÓDIGO CODE / CODE / CÓDIGO	DIMENSÕES DA FITA TAPE DIMENSIONS / DIMENSIONS DU RUBAN / DIMENSIONES DE LA CINTA	DIMENSÕES DA CAIXA CASE DIMENSIONS / DIMENSIONS DE LA BOITE / DIMENSIONES DE LA CAJA	EMBALAGEM QUANTITY / EMBALLAGE / EMBALAJE
000082303160	3 mt x 16 mm	60 mm x 70 mm x 35 mm	12
000082305190	5 mt x 19 mm	70 mm x 90 mm x 35 mm	12



**Travão duplo | Sem fixador magnético | Classe de medição II | Travão automático**  
Double stop | Non magnetic hook | EC - Class II accuracy | Self lock system  
Frein double | Sans fixateur magnétique | Classe de mesure II | Blocage automatique  
Freno doble | Sin fijador magnético | Clase de medición II | Freno automático





# FERRAMENTA MANUAL

Hand Tools / Outillage Manuel / Herramienta Manual

## Paquímetros

Vernier Calipers / Pieds à Coulisse / Paquímetros

### Paquímetro Digital / Digital Vernier Caliper / Pied à Coulisse Digital / Paquímetro Digital

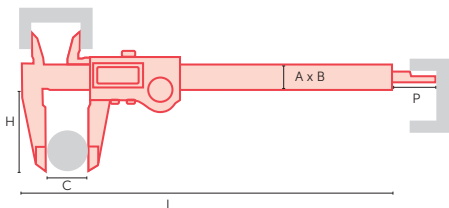

CÓDIGO CODE / CODE / CÓDIGO	PRECISÃO ACCURACY / PRÉCISION / PRECISIÓN	DESVIO (µm) BIAS ERROR / DÉLAI / DESVÍO	DIMENSÕES / DIMENSIONS / DIMENSIONS / DIMENSIONES				PESO WEIGHT / POIDS / PESO	EMBALAGEM / QUANTITY / EMBALLAGE / EMBALAJE
			A X B	C	L	H		
000085300150	0,01	20	17 x 3,5	150	233	40	465	1



**Paquímetro digital | Ecrã de fácil leitura | Eficiente e fiável**  
 Digital Vernier caliper | Easy to read, large display | Efficient and reliable  
 Pied à coulisse digital | Ecran de facile lecture | Efficient et fiable  
 Paquímetro digital | Pantalla de fácil lectura | Eficiente y fiable

### Paquímetro Universal 0-280 / Universal Vernier Caliper 0-280 / Pied à Coulisse Universel 0-280 / Paquímetro Universal 0-280

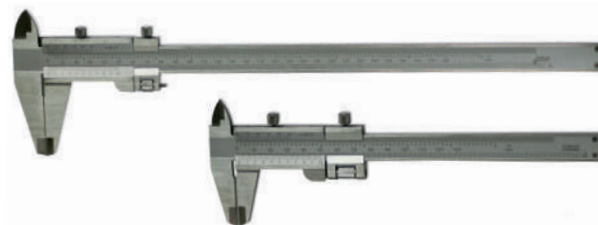
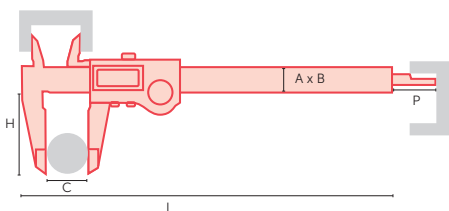

CÓDIGO CODE / CODE / CÓDIGO	PRECISÃO ACCURACY / PRÉCISION / PRECISIÓN	DESVIO (µm) BIAS ERROR / DÉLAI / DESVÍO	DIMENSÕES / DIMENSIONS / DIMENSIONS / DIMENSIONES				PESO WEIGHT / POIDS / PESO	EMBALAGEM / QUANTITY / EMBALLAGE / EMBALAJE
			A X B	C	L	H		
000085100280	0,02	30	17 x 3,5	200	290	50	419	1



**Normalizado DIN862 | Bom contraste e acabamento anti-reflexo | Precisão 0,02 mm (1/50mm)**  
 Compliance with Din 862 | Good contrast and anti-reflection | Accuracy 0,02 mm (1/50 mm)  
 Norme DIN862 | Bon contraste et finition anti-reflet | Précision 0,02 mm (1/50 mm)  
 Normalizado DIN862 | Buen contraste y acabado antirreflejo | Precisión 0,02 mm (1/50mm)

### Paquímetro Analógico Relógio / Analogic Clock Vernier Caliper / Pied à Coulisse à Montre Analogique / Paquímetro Analógico Reloj

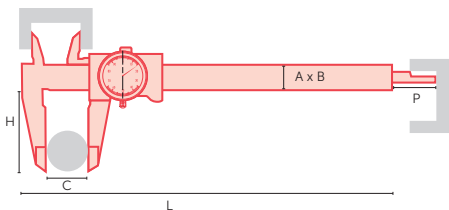

CÓDIGO CODE / CODE / CÓDIGO	PRECISÃO ACCURACY / PRÉCISION / PRECISIÓN	DESVIO (µm) BIAS ERROR / DÉLAI / DESVÍO	DIMENSÕES / DIMENSIONS / DIMENSIONS / DIMENSIONES				PESO WEIGHT / POIDS / PESO	EMBALAGEM / QUANTITY / EMBALLAGE / EMBALAJE
			A X B	C	L	H		
000085200150	0,01	20	17 x 3,5	150	236	40	338	1
000085200200	0,01	20	17 x 3,5	200	286	50	456	1



**Normalizado DIN862 | Bom contraste e fácil leitura**  
 Compliance with Din 862 | Good contrast and easy reading  
 Norme DIN862 | Bon contraste et lecture facile  
 Normalizado DIN862 | Buen contraste y fácil lectura



## Níveis

Spirit Levels / Niveaux / Niveles

### Nível HD com Pega

Heavy Duty Box Level / Niveau HD avec Poignée / Nivel HD con Asa

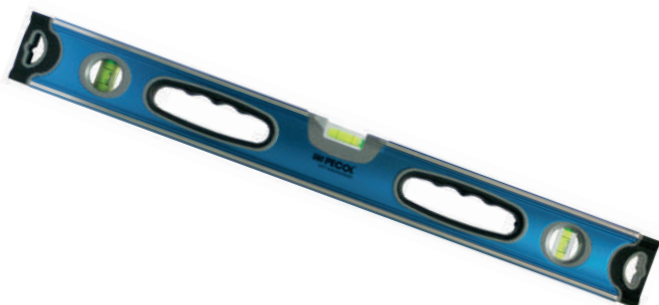

CÓDIGO CODE / CODE / CÓDIGO	DIMENSÕES DIMENSIONS / DIMENSIONS / DIMENSIONES	EMBALAGEM / QUANTITY / EMBALLAGE / EMBALAJE
000084020000	200 cm	1

000084020000      200 cm      1



#### Todo o tipo de aplicações em construção

All kind of levelling in building construction area  
Tous types d'application en construction  
Todo tipo de aplicaciones en construcción

### Medfix

Medfix / Medfix / Medfix



CÓDIGO CODE / CODE / CÓDIGO	DIMENSÕES DIMENSIONS / DIMENSIONS / DIMENSIONES	EMBALAGEM / QUANTITY / EMBALLAGE / EMBALAJE
000081030000	3 m	1

000081030000      3 m      1



#### Indispensável em muitos setores como indústria de caixilharia ou interiores

Useful in metal industry and covering industry  
Idéale pour l'industrie métallo-mécanique et de couvertures  
Ideal para la industria metalmeccánica y de coberturas

### Nível Digital

Digital Angular Level / Niveau Digital / Nivel Digital



CÓDIGO CODE / CODE / CÓDIGO	DIMENSÕES DIMENSIONS / DIMENSIONS / DIMENSIONES	EMBALAGEM / QUANTITY / EMBALLAGE / EMBALAJE
000084506000	600	1

000084506000      600      1



#### Ideal para a indústria metalomeccânica e de coberturas

Useful in metal industry and covering industry  
Idéale pour l'industrie métallo-mécanique et de couvertures  
Ideal para la industria metalmeccánica y de coberturas





# FERRAMENTA MANUAL

Hand Tools / Outillage Manuel / Herramienta Manual

## Nível Laser de Linhas XL2

Line Lasers XL2 / Niveau Laser Lignes XL2 / Nivel Láser de Líneas XL2



CÓDIGO CODE / CODE / CÓDIGO	FUNÇÃO FUNCTIONALITIES / FONCTION / FUNCIÓN	NÍVEL DE PRECISÃO ACCURACY / NIVEAU DE PRÉCISION / NIVEL DE PRECISIÓN	ALCANCE WORKING RANGE / PORTÉE / ALCANCE	EMBALAGEM / QUANTITY / EMBALLAGE / EMBALAJE
000084400001	Linha vertical e Linha horizontal / 1 horizontal line and 1 vertical line / Ligne verticale et Ligne horizontale / Línea vertical y Línea horizontal	+/- 2 mm / 5 m	10 metros / 10 meters / 10 mètres / 10 metros	1



### Instalação de tetos falsos, marcação de roços, nivelamento de quadros

Installing ceilings and levelling or aligning any other structural elements or objects

Installation de faux-plafonds, marquage de rainures nivelage de cadres

Instalación de Techos falsos, marcado de rozas, nivelado de cuadros

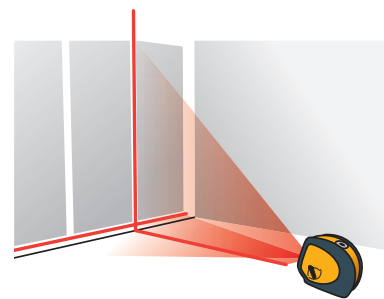
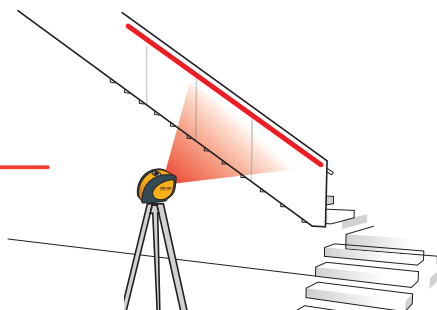
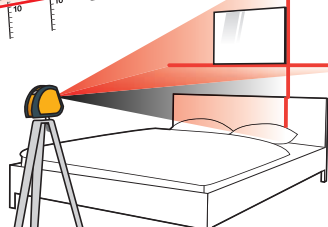
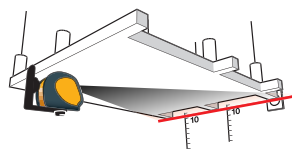

## Medidores de Distâncias Laser

Laser Distance Meters / Mesureurs de Distances par Laser / Medidores de Distancias Láser

### Medidor de Distâncias a Laser Prexiso 50

Laser Distance Meter Prexiso 50 / Mesureur de Distances par Laser Prexiso 50 / Medidor de Distancias a Láser Prexiso 50

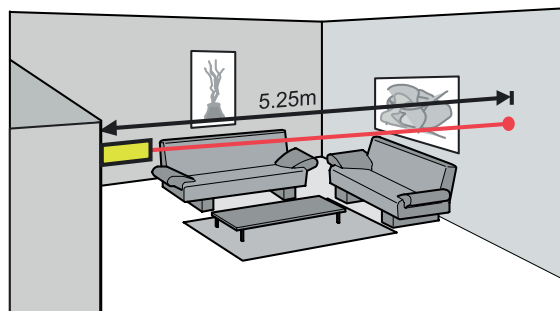
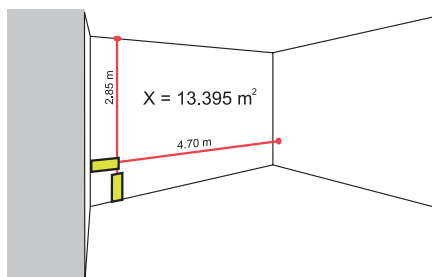

CÓDIGO CODE / CODE / CÓDIGO	ALCANCE / WORKING RANGE / PORTÉE / ALCANCE	NÍVEL DE PRECISÃO / ACCURACY / NIVEAU DE PRÉCISION / NIVEL DE PRECISIÓN	EMBALAGEM / QUANTITY / EMBALLAGE / EMBALAJE
000084400004	Entre 0,1 e 50 metros / From 0,1 to 50 meters / Entre 0,1 et 50 mètres / Entre 0,1 y 50 metros	+/- 2 mm	1



### Caixilharias de alumínio, construção civil, carpintarias, serralharias de ferro, produção de corrimões e escadarias, medição de áreas

Ideal to use on: Aluminum doors, windows and frames; construction; carpentry; metalwork; railings and staircases; area and volume calculation

Charpentiers en aluminium, construction civile, menuiseries, menuiseries de fer, production de rampes et escaliers, mesurage de surfaces

Armazones de aluminio, construcción civil, carpinterías, cerrajerías de hierro, fabricación de pasamanos y escaleras, medición de áreas





## Conjunto de Chaves de Precisão

Precision Screwdrivers Sets / Jeu de Tournevis de Précision / Conjunto de Llaves de Precisión



**CÓDIGO**  
CODE / CODE / CÓDIGO

**EMBALAGEM**  
QUANTITY / EMBALLAGE / EMBALAJE

00000078042

1



**Principais setores industriais, em especial no setor eletrônico**  
Major industrial sectors, particularly in the electronic industry  
Principaux secteurs industriels, spécialement dans le secteur électronique  
Principales sectores industriales, especialmente en el sector electrónico



**6 UNIDADES (4 CHAVES FENDA DE PRECISÃO + 2 CHAVES PHILLIPS DE PRECISÃO)**  
6 UNITS (4 PRECISION SLOTTED + 2 PRECISION PHILLIPS) / 6 UNITÉS (4 TOURNEVIS À FENTE DE PRÉCISION + 2 TOURNEVIS PHILLIPS DE PRÉCISION) / 6 UNIDADES (4 PLANAS DE PRECISIÓN + 2 PHILLIPS DE PRECISIÓN)

**DIMENSÕES / DIMENSIONS / DIMENSIONES**

**FENDA / SLOT / FENTE / PLANA**



1,5

2

2,5

3

**PHILLIPS / PHILLIPS / PHILLIPS / PHILLIPS**



0

1

-

-



## Alicates de Rebitar

Riveting Pliers / Pince à Riveter / Alicates para Remachar

### Alicate de rebitar PC1

PC1 Hand Riveting Plier / Pince à riveter PC1 / Alicates para Remachar PC1



### Alicate de rebitar PC2

PC2 Hand Riveting Plier / Pince à riveter PC2 / Alicates para Remachar PC2

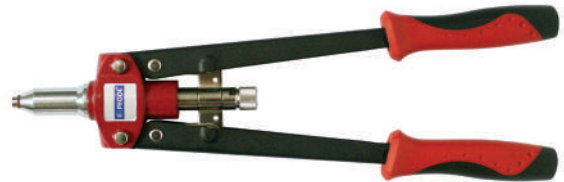

CÓDIGO CODE / CODE / CÓDIGO	TAMANHO SIZE / TAILLE / TAMAÑO	PESO WEIGHT / POIDS / PESO	EMBALAGEM QUANTITY / EMBALLAGE / EMBALAJE
049906024048	400	1160 gr	1



**Possibilidade de utilização de rebites com diâmetro entre 2,4 e 4,8mm**  
Possibility of using rivets between 2.4 to 4.8mm  
Possibilité d'utilisation de rivets de diamètre compris entre 2,4 et 4,8 mm  
Posibilidad de utilización de remaches con diámetro entre 2,4 y 4,8mm

CÓDIGO CODE / CODE / CÓDIGO	TAMANHO SIZE / TAILLE / TAMAÑO	PESO WEIGHT / POIDS / PESO	EMBALAGEM QUANTITY / EMBALLAGE / EMBALAJE
049904024048	400	1160 gr	1



**Para rebites de 2,4 a 4,8mm | Para porcas de cravar de 4 a 8mm | Para parafusos de rebitar entre 4 e 8mm**  
For rivets of 2.4mm to 4.8mm | To crimp nuts of from 4 to 8mm | For riveting of bolts from 4 to 8mm  
Pour rivets de 2,4 à 4,8 mm | Pour écrous noyés de 4 à 8 mm | Pour vis à riveter de 4 à 8 mm  
Para remaches de 2,4 hasta 4,8mm | Para tuercas de clavar de 4 hasta 8mm  
| Para tornillos de remache entre 4 y 8mm

### Alicate de rebitar com cabeça rotativa PC3 / PC3 Heavy Duty Riveting Plier

Pince à riveter à tête pivotante PC3 / Alicates para Remachar con cabeza rotatoria PC3



CÓDIGO CODE / CODE / CÓDIGO	TAMANHO SIZE / TAILLE / TAMAÑO	PESO WEIGHT / POIDS / PESO	EMBALAGEM QUANTITY / EMBALLAGE / EMBALAJE
049903032064	580	1890 gr	1



**Para porcas de cravar de 4 a 10mm | Para parafusos de rebitar entre 4 e 8mm**  
For crimp nuts from 4 to 10mm | For riveting of bolts 4 to 8mm  
Pour écrous noyés de 4 à 10 mm | Pour vis à riveter de 4 à 8 mm  
Para tuercas de clavar de 4 hasta 10mm | Para tornillos de remache entre 4 y 8mm

### Alicate de rebitar buchas PCL750 / Hand Riveting Plier for PCL750 Anchors

Pince à riveter chevilles PCL750 / Alicates para Remachar tacos PCL750



CÓDIGO CODE / CODE / CÓDIGO	TAMANHO SIZE / TAILLE / TAMAÑO	PESO WEIGHT / POIDS / PESO	EMBALAGEM QUANTITY / EMBALLAGE / EMBALAJE
049908040050	230	485 gr	1



**Para buchas PCL750 entre 4 e 6mm**  
For measures of 4mm to 6mm  
Pour Chevilles PCL750 entre 4 et 6 mm  
Para tacos PCL750 entre 4 y 6mm



# FERRAMENTA MANUAL

Hand Tools / Outillage Manuel / Herramienta Manual

## X-Ato

Utility Cutter Knives / Cutter / Cúter

### X-Ato X PEC 225

Plastic Utility Cutter Knives XPEC 225 / Cutter XPEC 225 / Cúter XPEC 225



CÓDIGO CODE / CODE / CÓDIGO	DIMENSÕES DIMENSIONS / DIMENSIONS / DIMENSIONES	LÂMINAS INCLUÍDAS BLADES INCLUDE / LAMES INCLUES / LÁMINAS INCLUIDAS	EMBALAGEM QUANTITY / EMBALLAGE / EMBALAJE
007215535000	155 x 35	5	1
007210018001	0,5 x 18	10	1



Todos os setores industriais, em especial a indústria de coberturas

Main sectors of industry special in the covering industry  
Tous les secteurs industriels, spécialement l'industrie de couvertures  
Todos los sectores industriales, especialmente la industria de coberturas

### X-Ato X PEC 335

Metallic Utility Knives XPEC 335 / Cutter XPEC 335 / Cúter XPEC 335



CÓDIGO CODE / CODE / CÓDIGO	DIMENSÕES DIMENSIONS / DIMENSIONS / DIMENSIONES	LÂMINAS INCLUÍDAS BLADES INCLUDE / LAMES INCLUES / LÁMINAS INCLUIDAS	EMBALAGEM QUANTITY / EMBALLAGE / EMBALAJE
007217038000	155 x 35	5	1
007217038001	-	10	1



Todos os setores industriais, em especial a indústria de coberturas

Main sectors of industry special in the covering industry  
Tous les secteurs industriels, spécialement l'industrie de couvertures  
Todos los sectores industriales, especialmente la industria de coberturas

## Tesoura Corte de Chapa

Tin Aviation Snips / Cisaille de Coupe de Tôle / Tijera Corte de Chapa



CÓDIGO CODE / CODE / CÓDIGO	TIPO TYPE / TYPE / TIPO	EMBALAGEM QUANTITY / EMBALLAGE / EMBALAJE
000884250002	Corte contorno esquerdo / Left Cut / Coupe de contour à gauche / Corte contorno izquierdo	1



Todos os setores da indústria

Main sectors of industry  
Tous les secteurs de l'industrie  
Todos los sectores de la industria

## Serrote

Handsaw / Scies / Serruchos

### Serrote Arco de Metal n.º 4 IRIMO

Aluminium Hacksaw Frame n.º 4 IRIMO / Monture de Scie à Métaux en Aluminium n.º 4 IRIMO / Arco para Metal n.º 4 IRIMO



CÓDIGO CODE / CODE / CÓDIGO	TAMANHO / SIZE / TAILLE / TAMAÑO			PESO (g) / WEIGHT (g) / POIDS (g) / PESO (g)	EMBALAGEM QUANTITY / EMBALLAGE / EMBALAJE
	A (mm)	H (mm)	L (mm)		
000011000284	110	151	400	665	1

### Serrote Universal IRIMO

General Purpose Handsaw IRIMO / Scies à Usage Universel IRIMO / Serrucho Universal IRIMO



CÓDIGO CODE / CODE / CÓDIGO	TAMANHO / SIZE / TAILLE / TAMAÑO			PESO (g) / WEIGHT (g) / POIDS (g) / PESO (g)	EMBALAGEM QUANTITY / EMBALLAGE / EMBALAJE
	mm				
000011000512	16	400		320	1
000011000351	20	500		360	1

### Serrote para metal de Alumínio IRIMO

Aluminium hacksaw frame IRIMO / Monture de scie à métaux aluminium IRIMO / Arco de sierra de aluminio IRIMO



CÓDIGO CODE / CODE / CÓDIGO	TAMANHO / SIZE / TAILLE / TAMAÑO	PESO (g) / WEIGHT (g) / POIDS (g) / PESO (g)	EMBALAGEM QUANTITY / EMBALLAGE / EMBALAJE
000011000534	400	665	1



A ferramenta ideal para qualquer actividade como indústria de caixilharia de alumínio ou aços. Canalizadores, eletricitistas e oficinas de reparação auto

The ideal tool for any activity such as aluminum or steel frame industry. Plumbers, electricians and auto repair shops  
L'outil idéal pour toute activité telle que l'industrie des châssis en aluminium ou en acier. Plombiers, électriciens et ateliers de réparation d'automobiles

La herramienta ideal para cualquier actividad como industria de carpintería de aluminio o aceros. Canalizadores, electricistas y talleres de reparación auto



## Grampo de Aperto em F (DIN 5117)

F Clamp / Serre-Joint en F (DIN 5117) / Sargento de Apriete en F (DIN 5117)



CÓDIGO CODE / CODE / CÓDIGO	TAMANHO / SIZE / TAILLE / TAMAÑO		EMBALAGEM QUANTITY / EMBALLAGE / EMBALAJE
	a (mm)	b (mm)	
000011015080	150	80	1
000011200100	200	100	1
000011250120	250	120	1
000011250140	250	140	1
000011030080	300	80	1
000011300120	300	120	1
000011300140	300	140	1
000011400120	400	120	1
000011500120	500	120	1
000011060080	600	80	1
000011600120	600	120	1
000011800120	800	120	1
000011000120	1000	120	1



**Para construção de mobiliário, carpintaria e trabalhos em madeira**  
For all professional usage in carpentry and woodworking and furniture construction  
Pour construction de mobilier, charpentes et travaux sur bois  
Para construcción de mobiliario, carpintería y trabajos en madera

## Grampo c/ Regulador de Aperto

Quick Lever Bar Clamp / Serre-Joint avec Régulateur / Sargento c/ Regulador de Apriete

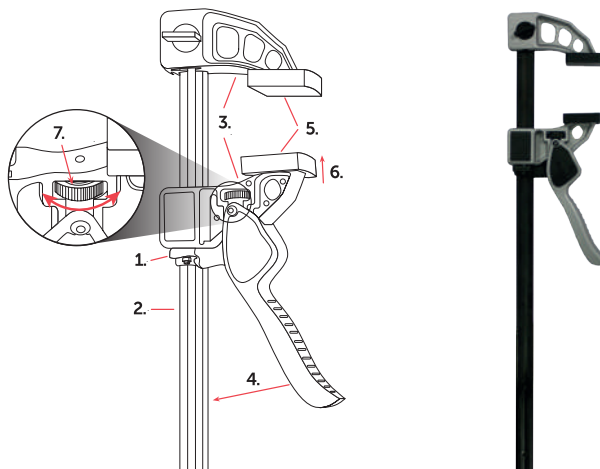

- |   |  |  |  |
|---|--|--|--|
| <b>1. Placa de fixação</b><br>1. Clutch plate<br>1. Plaque de fixation                                      | <b>2. Barra de aço</b><br>2. Barre en acier<br>2. Barra de acero   | <b>3. Garras de alumínio</b><br>3. Cast aluminum jaws<br>3. Bras de aluminium<br>3. Garras de aluminio             | <b>4. Punho de aperto</b><br>4. Depress handle to lock<br>4. Poignée de serrage<br>4. Mango de apriete |
| <b>5. Terminais de plástico</b><br>5. Non-marring pads<br>5. Mors en plastique<br>5. Terminales de plástico | <b>6. As garras exercem pressão quando apertadas</b><br>6. Jaw applies pressure as handle is locked<br>6. Les bras exercent pression quand serrées<br>6. Las garras ejercen presión cuando son apretadas | <b>7. Ajuste de pressão</b><br>7. Adjust pressure with thumbwheel<br>7. Plaque de fixation<br>7. Placa de fijación |  |

CÓDIGO CODE / CODE / CÓDIGO	DIMENSÕES DIMENSIONS / DIMENSIONES	EMBALAGEM QUANTITY / EMBALLAGE / EMBALAJE
000011000027	300 mm	1
000011000028	450 mm	1
000011000029	600 mm	1



**Todo o tipo de aplicações em construção**  
All kind of levelling in building construction area  
Tous types d'application en construction  
Todo tipo de aplicaciones en construcción

## Grampo de Aperto IRIMO

Screw clamp IRIMO / Serre-joints à cliquet en F IRIMO / Aprietos de émbolo IRIMO

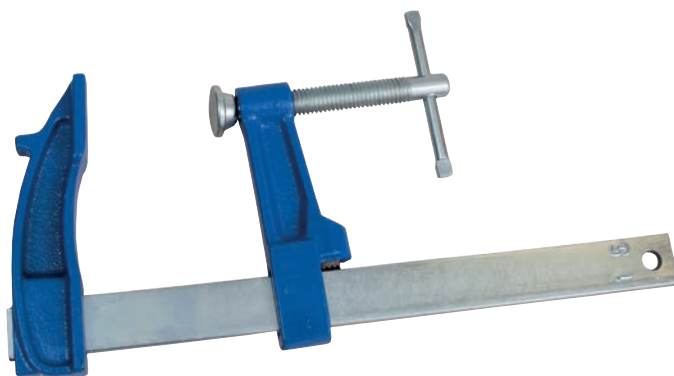

CÓDIGO CODE / CODE / CÓDIGO	DIMENSÕES / SIZE / DIMENSIONS / MEDIDA	EMBALAGEM QUANTITY / EMBALLAGE / EMBALAJE
000011000608	120x300	1
000011000346	120x400	1
000011000606	120x600	1
000011000862	120x800	1
000011000514	120x1000	1

## Grampo de Carpinteiro

Carpenter Clamp / Serre-Joint de Charpentier / Sargento de Carpintero



CÓDIGO CODE / CODE / CÓDIGO	TAMANHO / SIZE / TAILLE / TAMAÑO		EMBALAGEM QUANTITY / EMBALLAGE / EMBALAJE
	COMPRIMENTO (mm) WORKING LENGTH (mm) / LONGUEUR (mm) / LARGO (mm)	APERTO MÁXIMO (mm) MAXIMUM CLAMPING (mm) / SERRAGE MAXIMUM (mm) / APRIETE MÁXIMO (mm)	
000017000700	700	500	1
000017001000	1000	750	1
000017001200	1200	1050	1
000017001600	1600	1450	1



**Para construção de mobiliário, carpintaria e trabalhos em madeira**  
For all professional usage in carpentry and woodworking and furniture construction  
Pour construction de mobilier, charpenterie et travaux sur bois  
Para construcción de mobiliario, carpintería y trabajos en madera



# FERRAMENTA MANUAL

Hand Tools / Outillage Manuel / Herramienta Manual

## Armazenamento de Ferramentas

Tool Storage / Rangement Outils / Almacenamiento de Herramientas

### Mala de Ferramenta Metálica / Metallic tool boxes / Boîtes à outils métalliques / Caja Metálica con asa



CÓDIGO CODE / CODE / CÓDIGO	DIMENSÕES SIZE / DIMENSIONS / MEDIDA	PESO WEIGHT / POIDS / PESO	ESPESSURA DA CHAPA PLATE THICKNESS / EPAISSEUR DE LA PLAQUE / ESPESOR DE LA PLACA	EMBALAGEM QUANTITY / EMBALLAGE / EMBALAJE
000011000087	530x200x200	3.8 Kg	0.6 mm	1
000011000187	420x200x200	3 Kg	0.6 mm	1



**Possibilidade de se fechar a caixa com recurso a um aloquete | Tampa rebitada facilita o manuseamento e abertura da mala de ferramenta**

The box can be locked by padlock | Riveted lids make the opening easy

Possibilité de verrouiller la boîte en utilisant les ouvertures incorporées dans les couvercles avec un cadenas | Les couvercles rivetés permettent une ouverture facile

La caja se puede bloquear utilizando un candado | Tapas remachadas facilitan su apertura de una manera cómoda

RS 600

### Mala de Ferramenta RS 600 / Toolbox RS 600 / Sac D'outil RS 600 / Bolsa de Herramientas RS 600



CÓDIGO CODE / CODE / CÓDIGO	DIMENSÕES SIZE / DIMENSIONS / MEDIDA	CARGA MÁXIMA MAXIMUM LOAD / CHARGE MAXIMUM / CARGA MÁXIMA	PESO WEIGHT / POIDS / PESO	EMBALAGEM QUANTITY / EMBALLAGE / EMBALAJE
000011000183	580x280x275	15 kg	2.3	1



**Ideal para transportar e arrumar as mais diversas ferramentas**

Ideal for carrying and storing various hand tools

Idéal pour transporter et stocker les différents outils

Ideal para transportar y almacenar distintas herramientas



## Caixas Modulares

Modular boxes / Boîtes modulaires / Cajas Modulares



CÓDIGO CODE / CODE / CÓDIGO	DIMENSÕES SIZE / DIMENSIONS / MEDIDA	EMBALAGEM QUANTITY / EMBALLAGE / EMBALAJE
000011000501	125x195x90	60
000011000502	152x245x122	60
000011000503	265x420x177	20
000011000504	310x490x195	12



**Possibilidade de modelar as caixas encaixando-as na vertical por forma a criar um sistema de armazenamento integrado**

Allow to model the boxes by sliding them vertically in order to create an integrated storage system

Possibilité de manipuler les boîtes, les positionner verticalement, afin de créer un système de stockage intégré

Possibilidad de modelar las cajas encajándolas verticalmente con el fin de crear un sistema de almacenamiento integrado



## Formão e Guilho

Chisels / Burins / Formón y Cincel

Wood Chisel / Ciseau à Bois / Formón de Carpintero / Formão de Carpinteiro

CÓDIGO CODE / CODE / CÓDIGO	TAMANHO SIZE / TAILLE / TAMAÑO	EMBALAGEM QUANTITY / EMBALLAGE / EMBALAJE
000881019000	6	1
000881019001	10	1
000881019002	12	1
000881019003	16	1
000881019004	19	1
000881019005	22	1



**Produto perfeito e adequado a indústria da madeira**

The perfect and suitable product for the wood industry  
Le produit parfait et adéquat à l'industrie du bois  
El producto perfecto y adecuado para la industria de madera

## Ferramentas manuais para a construção

Construction Hand Tools / Outils manuels de construction / Herramientas manuales para la construcción

### Picareta

Chipping hammer / Pioche / Picareta



### Pás de Construção

Shovel / Pelles de Construction / Pás de Construção

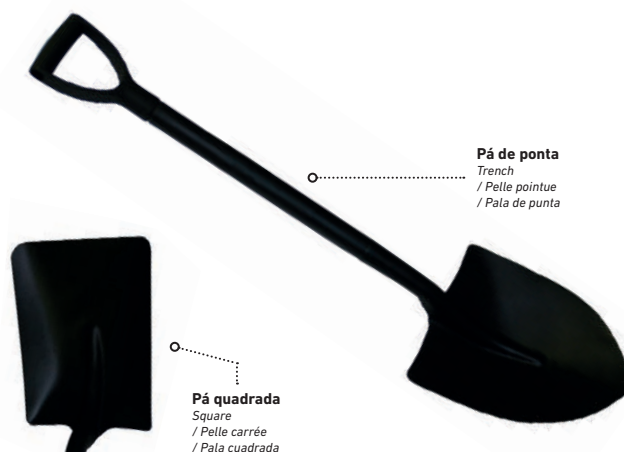

CÓDIGO CODE / CODE / CÓDIGO	PESO WEIGHT / POIDS / PESO	EMBALAGEM QUANTITY / EMBALLAGE / EMBALAJE
000886702000	2 Kg	1
000886703000	3 Kg	1

CÓDIGO CODE / CODE / CÓDIGO	PESO WEIGHT / POIDS / PESO	EMBALAGEM QUANTITY / EMBALLAGE / EMBALAJE
000886704000	1,7 Kg	1
000886704001	1,8 Kg	1



**Adequado à indústria da construção**

Suitable for masonry industry  
Adéquat à l'industrie de construction  
Adecuado para la industria de la construcción



**Adequado à indústria da construção**

Suitable for masonry industry  
Adéquat à l'industrie de construction  
Adecuado para la industria de la construcción





# FERRAMENTA MANUAL

Hand Tools / Outillage Manuel / Herramienta Manual

## Colheres de Pedreiro

Trowels (Construction Trowels) / Truelles de Maçon / Paletas de Albañil



**Colher de pedreiro direita**  
Straight Type  
/ Truelle de maçon ronde  
/ Paleta de albañil plana



**Colher de pedreiro cantos cortados**  
builder's trowel with cutted corners  
/ Truelle coins arrondis  
/ Paleta de albañil de cantos cortados



**Colherim**  
Small builder's trowel  
/ Truelle triangulaire  
/ Paletilla



	CÓDIGO CODE / CODE / CÓDIGO	TAMANHO SIZE / TAILLE / TAMAÑO	EMBALAGEM QUANTITY / EMBALLAGE / EMBALAJE
<b>Colher de pedreiro direita</b> / Straight Type / Truelle de maçon ronde / Paleta de albañil plana	000886704011	250	1
<b>Colher de pedreiro cantos cortados</b> / builder's trowel with cutted corners / Truelle coins arrondis / Paleta de albañil de cantos cortados	000886704012	250	1
<b>Colherim</b> / Small builder's trowel / Truelle triangulaire / Paletilla	000886704010	140	1



**Indústria de construção e de reboco**  
Building construction industry and dry wall industry  
Industrie de construction et de crépi  
Industria de construcción y de revoco

## Talochas

Trowels / Taloches / Talochas

### Talocha Plástica nº2

Plastic Trowel nº2 / Taloché Plastique nº2 / Talocha Plástica nº2



### Talocha Plástica com Espuma

Plastic Trowel with foam / Taloché éponge / Llana plástica con espuma



### Talocha de borracha

Rubber Trowel / Taloché en Caoutchouc / Talocha de Goma



CÓDIGO / CODE / CODE / CÓDIGO	DIMENSÕES / SIZE / DIMENSIONS / MEDIDA	EMBALAGEM / QUANTITY / EMBALLAGE / EMBALAJE
000886704036	340x210	1



Utilizada para acabamento de paredes e fachadas  
Used for plastering walls, walls and facades  
Utilisée pour finition de murs et façades  
Utilizada para acabado de paredes y fachadas

CÓDIGO / CODE / CODE / CÓDIGO	DIMENSÕES / SIZE / DIMENSIONS / MEDIDA	EMBALAGEM / QUANTITY / EMBALLAGE / EMBALAJE
00886704024	280x140	1



Utilizada para aplicar e regularizar massas em paredes  
Used to plaster and smoothing of walls  
Utilisée pour appliquer et régulariser les pâtes sur les murs  
Utilizada para aplicar e regularizar masas en paredes

CÓDIGO / CODE / CODE / CÓDIGO	DIMENSÕES / SIZE / DIMENSIONS / MEDIDA	EMBALAGEM / QUANTITY / EMBALLAGE / EMBALAJE
000886704023	280X130X20	1



Ideal para trabalhos em cerâmica  
Suitable for ceramic adjustment  
Utilisée pour travaux en céramique  
Adecuado para trabajos en cerámica



## Espátulas de Construção

Construction Spatulas / Spatules de Construction / Espátulas de Construcción

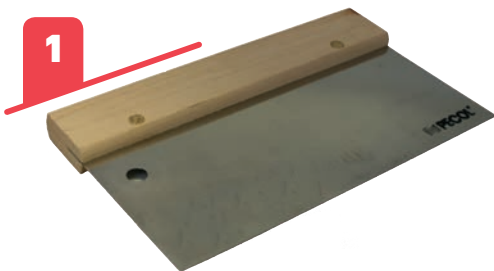

1



3

		<b>CÓDIGO</b> CODE / CODE / CÓDIGO	<b>DIMENSÕES</b> SIZE / DIMENSIONS / MEDIDA	<b>EMBALAGEM</b> QUANTITY / EMBALLAGE / EMBALAJE
<b>1</b>	<b>Espátula reta</b> / Smooth Spatula / Spatule droite / Espátula recta	000886704020	200	12
<b>2</b>	<b>Espátula para gesso</b> / Spatula for Plaster / Spatule pour plâtre / Espátula para yeso	000886704022	500	12



**Aplicação de colas, adesivos, gesso e gesso cartonado | Construção em geral**  
Application of glues, adhesive, plaster and plasterboard joints | Construction in General  
Application de colles, adhésifs, plâtre et plâtre cartonné | Construction en générale  
Aplicación de pegamentos, adhesivos, yeso y yeso acartonado | Construcción en general



## Espátulas

Spatulas / Spatules / Espátulas

### Espátula de Borracha

Rubber Spatula / Spatule en Caoutchouc / Espátula de Goma



<b>CÓDIGO</b> CODE / CODE / CÓDIGO	<b>TAMANHO</b> SIZE / TAILLE / TAMAÑO	<b>EMBALAGEM</b> QUANTITY / EMBALLAGE / EMBALAJE
000886704035	300	12



**Utilizável para preenchimento de juntas**  
Used for filling joints  
Utilisable pour remplissage de joints  
Utilizable para retleno de juntas

### Espátula Flexível

Flexible Spatula / Spatule Flexible / Espátula Flexible



<b>CÓDIGO</b> CODE / CODE / CÓDIGO	<b>TAMANHO</b> SIZE / TAILLE / TAMAÑO	<b>EMBALAGEM</b> QUANTITY / EMBALLAGE / EMBALAJE
000886704027	25	12
000886704028	38	12
000886704029	50	12
000886704030	60	12
000886704031	75	12
000886704032	100	12
000886704033	120	12
000886704034	150	12



**Ideal para aplicação de gesso, cola e massa**  
Ideal for applying plaster, glues and putties  
Idéale pour application de plâtre, colle et pâtes  
Idéal para aplicación de yeso, pegamento y masilla



# FERRAMENTA MANUAL

Hand Tools / Outillage Manuel / Herramienta Manual

## Baldes e Gamelas

Buckets and Troughs / Seaux et Auges / Cubos y Artesas

Balde / Bucket / Seau / Cubo



CÓDIGO	CAPACIDADE	EMBALAGEM
CODE / CODE / CÓDIGO	CAPACITY / CAPACITÉ / CAPACIDAD	QUANTITY / EMBALLAGE / EMBALAJE
000886704005	10 lts	25
000886704006	15 lts	1



Para uso em locais de construção  
For use in construction sites  
Pour usage sur sites de construction  
Para uso en lugares de construcción

Gamelas / Troughs / Auges / Artesas



CÓDIGO	CAPACIDADE	EMBALAGEM
CODE / CODE / CÓDIGO	CAPACITY / CAPACITÉ / CAPACIDAD	QUANTITY / EMBALLAGE / EMBALAJE
000886704007	35 lts	1



Para uso em locais de construção  
For use in construction sites  
Pour usage sur sites de construction  
Para uso en lugares de construcción



## Balde Pintura

Painting Bucket / Seau à Peinture / Balde Pintura

### Balde Premium 16Lt + Grelha

16L Premium Bucket + Grid / Seau Premium 16Lt + Grille / Balde Premium 16Lt + Rejilla



CÓDIGO	CAPACIDADE	DIMENSÕES	EMBALAGEM
CODE / CODE / CÓDIGO	CAPACITY / CAPACITÉ / CAPACIDAD	SIZE / DIMENSIONS / MEDIDA	QUANTITY / EMBALLAGE / EMBALAJE
000011001030	16 lts	36,3 x 31 x 19,5cm	1



Superfície plana para suporte de trinchas | Lateral delineado para verter líquidos facilmente  
Flat surface for brush holder | Side designed to pour liquids easily  
Surface plane pour porte-brosse | Latéral conçue pour verser des liquides facilement / Superficie plana para soporte de brochas | Lateral delineado para verter líquidos fácilmente







## Rolos de Pintura

Painting Rollers / Rouleaux à peinture / Rodillos de Pintura

Special Railing Mini Roller / Mini Rouleau Spécial Grillages / Mini Rodillo Especial Rejillas / Mini Rolo Especial Gradeamentos

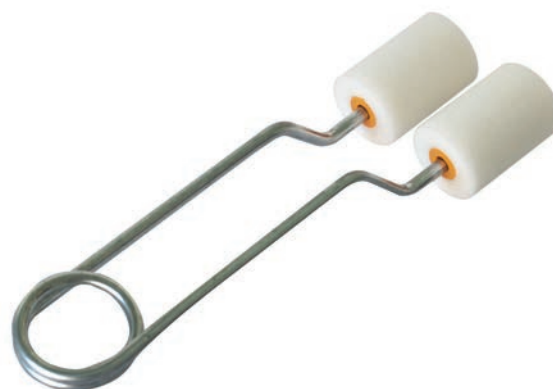
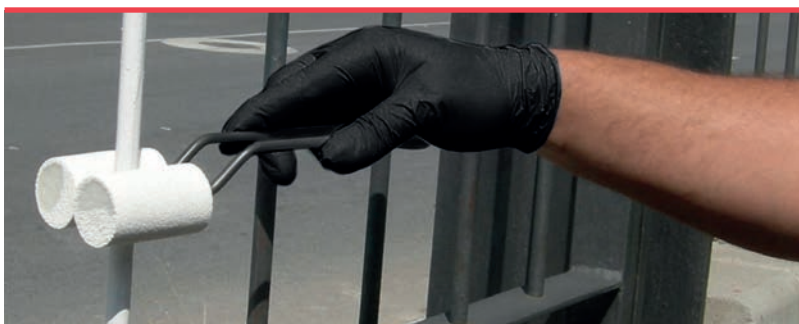

CÓDIGO CODE / CODE / CÓDIGO	DIMENSÕES SIZE / DIMENSIONS / MEDIDA	EMBALAGEM QUANTITY / EMBALLAGE / EMBALAJE
000011001027	5cm	8



**Permite o uso de recargas convencionais de 6mm | Recarga fácil | Ideal para superfícies lisas e baixas**  
*Allows the use of conventional 6mm refills | Easy Recharge | Ideal for smooth and low surfaces*  
*Permet l'utilisation de recharges classiques 6mm | Recharge facile | Idéal pour les surfaces lisses et basses*  
*Permite el uso de recargas convencionales de 6mm | Recarga fácil | Ideal para superficies lisas y bajas*

Mini Corner Roller Premium / Mini rouleau d'angle Premium / Mini Rodillo Premium para Cantos / Mini Rolo para Cantos Premium



CÓDIGO CODE / CODE / CÓDIGO	DIMENSÕES SIZE / DIMENSIONS / MEDIDA	EMBALAGEM QUANTITY / EMBALLAGE / EMBALAJE
000011001028	10 cm	10
000011001029	10 cm	24



**Recortes retos e limpos | Uso fácil e rápido**  
*Straight and clean cutouts | Easy and quick use*  
*Découpes droites et propres | Utilisation facile et rapide*  
*Recortes rectos y limpios | Uso fácil y rápido*

Anti-Drop Roller / Rouleau Anti-gouttes / Rodillo Antigoteo / Rolo Antigota

CÓDIGO CODE / CODE / CÓDIGO	DIMENSÕES SIZE / DIMENSIONS / MEDIDA	EMBALAGEM QUANTITY / EMBALLAGE / EMBALAJE
000011001011	18 cm	30
000011001012	22 cm	30



**Resistente a solventes | Ideal para paredes interiores e substratos lisos**  
*Solvent resistant | Ideal for interior walls and smooth substrates*  
*Résistant aux solvants | Idéal pour les murs intérieurs et les substrats lisses*  
*Resistente a los disolventes | Ideal para paredes interiores y sustratos lisos*





# FERRAMENTA MANUAL

Hand Tools / Outillage Manuel / Herramienta Manual

## Rolo Fachadas / Facades Roller / Rouleau Façades / Rodillo Fachadas



CÓDIGO CODE / CODE / CÓDIGO	DIMENSÕES SIZE / DIMENSIONS / MEDIDA	EMBALAGEM QUANTITY / EMBALLAGE / EMBALAJE
000011001013	18 cm	30
000011001014	22 cm	30



**Ideal superfícies irregulares, tijolo, blocos, reboco e trabalhos de impermeabilização**

*Ideal for irregular surfaces, brick, blocks, plaster and waterproofing works*

*Idéal pour les surfaces irrégulières, brique, blocs, plâtre et travaux d'imperméabilisation*

*Ideal superficies irregulares, ladrillo, bloques, revoque y trabajos de impermeabilización*

## Rolo Esmalte e Verniz Angorá / Angora Enamel and Varnish Roller / Rouleau Email et Vernis Angora / Rodillo Esmalte y Barniz Angora



CÓDIGO CODE / CODE / CÓDIGO	DIMENSÕES SIZE / DIMENSIONS / MEDIDA	EMBALAGEM QUANTITY / EMBALLAGE / EMBALAJE
000011001015	11 cm	24
000011001016	18 cm	30



**Ideal superfícies metálicas e madeiras**

*Ideal for metal surfaces and woods*

*Idéal pour les surfaces métalliques et bois*

*Ideal superficies metálicas y maderas*

## Rolo Tinta Texturada / Textured Ink Roller / Rouleau Peinture Texturé / Rodillo Tinta Texturizada



CÓDIGO CODE / CODE / CÓDIGO	DIMENSÕES SIZE / DIMENSIONS / MEDIDA	EMBALAGEM QUANTITY / EMBALLAGE / EMBALAJE
000011001017	22 cm	10



**Ideal para fazer texturas em paredes**

*Ideal for textures on walls*

*Idéal pour faire des textures sur les murs*

*Ideal para hacer texturas en paredes*





## Acessórios de Pintura

Painting Accessories / Accessoires de peinture / Accesorios de Pintura

Frame w/Cable for Mini Roller / Armature avec Câble pour Mini Rouleaux / Armadura con Cable para Mini Rodillo / Armação com Cabo para Mini Rolo

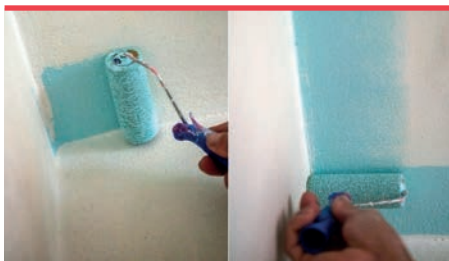

CÓDIGO CODE / CODE / CÓDIGO	DIMENSÕES SIZE / DIMENSIONS / MEDIDA	EMBALAGEM QUANTITY / EMBALLAGE / EMBALAJE
000011001018	11 cm	20



**Permite o acesso a lugares difíceis | Ideal para efectuar pequenos retoques e acabamentos**

Allows access to difficult places | Ideal for small touches and finishes  
Permet l'accès aux endroits difficiles | Idéal pour les petites retouches et finitions  
Permite el acceso a lugares difíciles | Ideal para realizar pequeños retoques y acabados



Mini Tray / Mini Plateau / Mini Tablero / Mini Tabuleiro

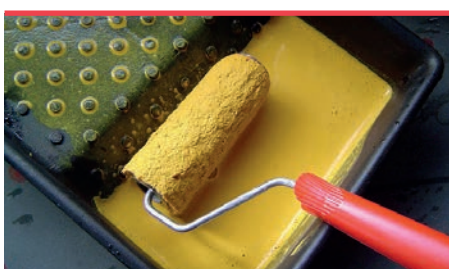

CÓDIGO CODE / CODE / CÓDIGO	DIMENSÕES SIZE / DIMENSIONS / MEDIDA	EMBALAGEM QUANTITY / EMBALLAGE / EMBALAJE
000011001022	160x290x55 mm	24



**Ideal para distribuir uniformemente a tinta pelo rolo**

Ideal for evenly distributing ink by roller  
Idéal pour répartir uniformément l'encre au rouleau  
Ideal para distribuir uniformemente la tinta por el rodillo



2m Metal Extender Cable / Câble d'Extension en Métal 2mts / Cable Extensor Metálico 2mts / Cabo Extensor Metálico 2mts



CÓDIGO CODE / CODE / CÓDIGO	DIMENSÕES SIZE / DIMENSIONS / MEDIDA	EMBALAGEM QUANTITY / EMBALLAGE / EMBALAJE
000011001023	2m (1x1m)	12



**Indicado para pintura em locais de difícil acesso, evitando o uso de escada**

Indicated for painting in places of difficult access, avoiding the use of stairs  
Indiqué pour la peinture dans les endroits difficiles d'accès, en évitant l'utilisation d'escaliers  
Indicado para pintar en lugares de difícil acceso, evitando el uso de escalera



## Packs Rolos

Roller Packs / Packs Rouleaux / Packs Rodillos

### Pack 2 carga Mini Rolo Antigota

Pack of 2 Mini Anti-Drop Roller Charges / Pack 2 charge Mini Rouleau Anti-Goutte / Pack 2 carga Mini Rodillo Antigota



CÓDIGO / CODE / CODE / CÓDIGO	DIMENSÕES / SIZE / DIMENSIONS / MEDIDA	EMBALAGEM / QUANTITY / EMBALLAGE / EMBALAJE
000011001019	110 mm	50



**Ideal para superfícies planas | Boa cobertura e acabamento**

Ideal for flat surfaces | Good coating and finish  
Idéal pour les surfaces planes | Bonne couverture et finition  
Ideal para superficies planas | Buena cobertura y acabado

### Pack 2 carga Mini Rolo Esmalte Aquoso Espuma

Pack of 2 Enamel Aqueous Foam Mini Roller Charges / Pack 2 charge Mini Rouleau Email Aqueux Mousse / Pack 2 de carga Mini Rodillo Esmalte Acuoso Espuma



CÓDIGO / CODE / CODE / CÓDIGO	DIMENSÕES / SIZE / DIMENSIONS / MEDIDA	EMBALAGEM / QUANTITY / EMBALLAGE / EMBALAJE
000011001020	110 mm	30



**Ideal para Pequenas superfícies lisas | Bom acabamento**

Ideal for small smooth surfaces | Good finish  
Idéal pour les petites surfaces lisses | Bonne finition  
Ideal para pequeñas superficies lisas | Buen acabado

### Pack 2 carga Mini Rolo Esmalte e Verniz Angorá

Pack of 2 Angora Enamel and Varnish Mini Roller Charges / Pack 2 charge Mini Rouleau Email et Vernis Angora / Pack 2 carga Mini Rodillo Esmalte y Barniz Angora



CÓDIGO / CODE / CODE / CÓDIGO	DIMENSÕES / SIZE / DIMENSIONS / MEDIDA	EMBALAGEM / QUANTITY / EMBALLAGE / EMBALAJE
000011001021	110 mm	50



**Ideal para Pequenas superfícies | Acabamento fino para todo tipo de esmaltes**

Ideal for Small Surfaces | Fine finish for all types of enamels  
Idéal pour les Petites surfaces | Excellente finition pour tous les types d'émaux  
Ideal para pequeñas superficies | Acabado fino para todo tipo de esmaltes



# FERRAMENTA MANUAL

Hand Tools / Outillage Manuel / Herramienta Manual

## Trinchas

Brushes / Broses / Trincheras

### Trincha Super Pro

Super Pro Brush / Brosse Super Pro / Trincha Super Pro



CÓDIGO CODE / CODE / CÓDIGO	DIMENSÕES SIZE / DIMENSIONS / MEDIDA	EMBALAGEM QUANTITY / EMBALLAGE / EMBALAJE
000011001024	25 mm	12
000011001025	40 mm	12
000011001026	50 mm	12



**Ideal para todo o tipo de superfícies**

*Ideal for all types of surfaces  
Idéal pour tous les types de surfaces  
Ideal para todo tipo de superficies*



### Trincha Junior Cerda Pura

Junior Pure Bristle Brush / Brosse Junior en Soie Pure / Trincha Junior de Cerda Pura



CÓDIGO CODE / CODE / CÓDIGO	DIMENSÕES SIZE / DIMENSIONS / MEDIDA	ESPESSURA THICKNESS / ÉPAISSEUR / ESPESOR	EMBALAGEM QUANTITY / EMBALLAGE / EMBALAJE
000011001000	25 mm	13	12
000011001001	40 mm	16	12
000011001002	50 mm	16	12
000011001003	60 mm	16	12
000011001004	75 mm	16	12



**Ideal para todo o tipo de superfícies**

*Ideal for all types of surfaces  
Idéal pour tous les types de surfaces  
Ideal para todo tipo de superficies*



## Pincéis

Brushes / Pinceaux / Cepillos

### Pincel Redondo Super / Super Round Brush / Pinceau Rond Super / Cepillo Redondo Super

CÓDIGO CODE / CODE / CÓDIGO	DIMENSÕES SIZE / DIMENSIONS / MEDIDA	EMBALAGEM QUANTITY / EMBALLAGE / EMBALAJE
000011001005	4 mm	12
000011001006	8 mm	12
000011001007	12 mm	12
000011001008	16 mm	12
000011001009	20 mm	12



**Ideal para pinturas delicadas e em pequenas superfícies**

*Ideal for delicate paints and on small surfaces  
Idéal pour les peintures délicates et petites surfaces  
Ideal para pinturas delicadas y en pequeñas superficies*

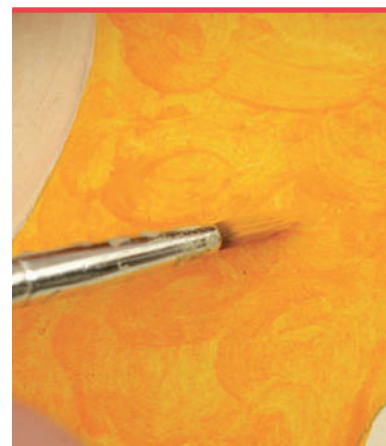



# MANUTENÇÃO E ORGANIZAÇÃO

*MAINTENANCE AND ORGANIZATION*

*MAINTENANCE ET ORGANISATION*

*MANTENIMIENTO Y ORGANIZACIÓN*



# MANUTENÇÃO E ORGANIZAÇÃO

Maintenance and Organization / Maintenance et Organisation / Mantenimiento y Organización

## Projetores de Trabalho

Energy Saves Work Light / Projeteurs de Travail / Projectores de Trabajo

### Projetor de LED / LED Work Light / Projecteur de LED / Proyector de LED



IP65

CÓDIGO CODE / CODE / CÓDIGO	DIMENSÕES DIMENSIONS / DIMENSIONS / DIMENSIONES	POTÊNCIA POWER / PUISSANCE / POTENCIA	EMBALAGEM QUANTITY / EMBALLAGE / EMBALAJE
009020397000	115x87x87	10W	1
009020398000	225x126x185	30W	1
009020399000	290x150x240	50W	1



**Projetores LED em alumínio para utilização em interior e exterior**

LED Work Light in aluminum for use in interior and exterior  
Projecteur de LED en aluminium pour une utilisation en intérieur et en extérieur  
Projectores LED en aluminio para uso en interior y exterior

### Projetor M18 SAL/0

Work Light M18 SAL/0 / Projecteur M18 SAL/0  
/ Proyector M18 SAL/0



IP54

7.3Kg

<b>Voltagem (V)</b> / Voltage (V) / Tension (V) / La tensión (V)	18
<b>Luminosidade máxima (Lumens)</b> / Maximum brightness (Lumens) / Maximum de luminosité (lumens) / Brillo máximo (lúmenes)	2000
<b>Fornecida em</b> / Supplied in / Fournie avec / Se suministrada en	<b>Caixa cartão</b> / Card Box / Boîte de carte / Caja de cartón
<b>Código</b> Code / Code / Código	001190451246

### Projetor M18 HSAL/0

Work Light M18 HSAL/0 / Projecteur M18 HSAL/0  
/ Proyector M18 HSAL/0

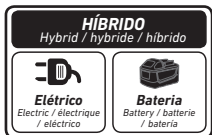

8.3Kg

IP54

<b>Voltagem (V)</b> / Voltage (V) / Tension (V) / La tensión (V)	18 / 230
<b>Luminosidade máxima (Lumens)</b> / Maximum brightness (Lumens) / Maximum de luminosité (lumens) / Brillo máximo (lúmenes)	3000
<b>Fornecida em</b> / Supplied in / Fournie avec / Se suministrada en	<b>Caixa cartão</b> / Card Box / Boîte de carte / Caja de cartón
<b>Código</b> Code / Code / Código	001190451392

### Foco Híbrido M18 HAL/0

Hybrid Focus M18 HAL/0 / Focus hybride M18 HAL/0  
/ Enfoque híbrido M18 HAL/0

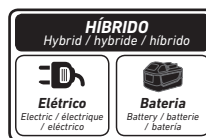

IP54

3.54Kg



<b>Voltagem (V)</b> / Voltage (V) / Tension (V) / La tensión (V)	18V
<b>Luminosidade máxima (Lumens)</b> / Maximum brightness (Lumens) / Maximum de luminosité (lumens) / Brillo máximo (lúmenes)	3000/1500/650
<b>Fornecida em</b> / Supplied in / Fournie avec / Se suministrada en	<b>Caixa cartão</b> / Card Box / Boîte de carte / Caja de cartón
<b>Código</b> Code / Code / Código	001190451262





## Extensões Elétricas

Cable Reel / Rallonge Électrique / Extensiones Eléctricas

### Extensão Elétrica c/ Cabo de 1,5 mm<sup>2</sup>

Cable Reel w/ Cable Section 1,5 mm<sup>2</sup> / Rallonge Électrique a/ Câble de 1,5 mm<sup>2</sup> / Extensión Eléctrica c/ Cable de 1,5 mm<sup>2</sup>



### Extensão Elétrica c/ Cabo de 2,5 mm<sup>2</sup>

Cable Reel w/ Cable Section 2,5 mm<sup>2</sup> / Rallonge Électrique a/ Câble de 2,5 mm<sup>2</sup> / Extensión Eléctrica c/ Cable de 2,5 mm<sup>2</sup>

CÓDIGO CODE / CODE / CÓDIGO	DIMENSÕES DIMENSIONS / DIMENSIONS		EMBALAGEM QUANTITY / EMBALLAGE / EMBALAJE
	COMPRIMENTO LENGTH / LONGUEUR / LARGO	Ø CABO Ø CÂBLE / Ø CÂBLE / Ø CABLE	
00000071000	50 mts	1,5 mm <sup>2</sup>	1
00000071001	25 mts	1,5 mm <sup>2</sup>	1

CÓDIGO CODE / CODE / CÓDIGO	DIMENSÕES DIMENSIONS / DIMENSIONS		EMBALAGEM QUANTITY / EMBALLAGE / EMBALAJE
	COMPRIMENTO LENGTH / LONGUEUR / LARGO	Ø CABO Ø CÂBLE / Ø CÂBLE / Ø CABLE	
00000072000	50 mts	2,5 mm <sup>2</sup>	1
00000072001	25 mts	2,5 mm <sup>2</sup>	1



**Cabo com secção de 1,5 mm<sup>2</sup> | Comprimento do cabo 25 ou 50mts | 4 tomadas c/ disjuntor de proteção | Bobine em plástico**  
Cable with 1,5 mm<sup>2</sup> section | Cable length 25 or 50 meters | 4 sockets w/ circuit breaker protection | Coil in plastic and metal stand  
Câble avec section de 1,5 mm<sup>2</sup> | Longueur du câble 25 ou 50 m | 4 prises avec disjuntor de protection | Bobine en plastique  
Cable con sección de 1,5 mm<sup>2</sup> | Largo del cable 25 o 50mts | 4 enchufes c/ disyuntor de protección | Bobina de plástico



**Cabo com secção de 2,5 mm<sup>2</sup> | Comprimento do cabo 25 ou 50mts | 4 tomadas c/ tampa e proteção com disjuntor | Bobine em metal**  
Cable with 2,5 mm<sup>2</sup> section | Cable length 25 or 50 meters | 4 water proof sockets with lid and circuit breaker protection | Metal Coil  
Câble avec section de 2,5 mm<sup>2</sup> | Longueur du câble 25 ou 50 m | 4 prises avec disjuntor de protection | Bobine en métal  
Cable con sección de 2,5 mm<sup>2</sup> | Largo del cable 25 o 50mts | 4 enchufes c/ tapa y protección con disyuntor | Bobina en metal

## Rolos de Papel e Suportes

Industrial Paper Rolls and Supports / Rouleaux de Papier et Supports / Rollos de Papel y Soportes

### Rolos de papel

/ Industrial Paper Rolls / Rouleaux de Papier / Rollos de Papel



CÓDIGO CODE / CODE / CÓDIGO	DIMENSÕES SIZE / DIMENSIONS / MEDIDA	EMBALAGEM QUANTITY / EMBALLAGE / EMBALAJE
002703302300	450 x 240	2



**Os rolos de papel de limpeza são ideais para remover sujidades de óleos, gorduras e outros químicos de modo a deixar as superfícies limpas**  
These industrial paper rolls are ideal for cleaning dirt such as: oil, grease or other chemicals  
Les rouleaux de papier de nettoyage sont idéals pour retirer la saleté d'huiles, graisses et autres chimiques de façon à laisser les surfaces propres  
Los rollos de papel de limpieza son ideales para eliminar suciedades de aceites, grasas y otros químicos de forma que las superficies se queden limpias

### Suportes para rolos de papel

/ Paper Rolls Dispenser / Supports pour Rouleaux de Papier / Soportes para Rollos de Papel



CÓDIGO CODE / CODE / CÓDIGO	DIMENSÕES SIZE / DIMENSIONS / MEDIDA	EMBALAGEM QUANTITY / EMBALLAGE / EMBALAJE
002704053750	405 x 375 x 330	1
002708004050	840 x 405 x 460	1



**Os suportes para rolos de papel são produzidos em tubo metálico de forma a garantir uma maior estabilidade e durabilidade do produto, ideal para utilização em oficinas, fábricas e manutenções de empresas**  
These dispensers for industrial paper rolls are manufactured in metal tube to ensure greater stability and durability, ideal for use in workshops, factories and maintenance companies  
Les supports pour rouleaux de papier sont produits en tube métallique de forme à garantir une plus grande stabilité et durabilité du produit, idéal pour utilisation en garages, usines et maintenance d'entreprises  
Los soportes para rollos de papel son fabricados en tubo metálico de forma que garantizan mayor estabilidad y durabilidad del producto, ideal para utilización en talleres, fábricas y mantenimiento de empresas



# MANUTENÇÃO E ORGANIZAÇÃO

Maintenance and Organization / Maintenance et Organisation / Mantenimiento y Organización

## Carregador de baterias / Battery charger / Chargeur de batterie / Cargador de batería



**RASO**  
INNOVATION & TECHNOLOGY

IP20



<b>Dimensões</b> / Size / Dimensions / Medida	300x210x185
<b>Potência</b> / Power / Puissance / Potencia	120-160 W
<b>Peso</b> / Weight / Poids / Peso	5,8 Kg
<b>Embalagem</b> / Quantity / Embalaje / Embalaje	1
<b>Código</b> / Code / Code / Código	000011000109

## BOOSTER X7

## Booster / Booster / Booster / Booster

**RASO**  
INNOVATION & TECHNOLOGY



<b>Dimensões</b> Size / Dimensions / Medida	181.3x95x40.3
<b>Peso</b> Weight / Poids / Peso	607 g
<b>Capacidade de carga</b> Battery capacity / Capacité des batteries / Capacidad de la batería	15000 mAh (55.5 Wh)
<b>Tempo integral de carregamento</b> Charger supplied / Temps de charge de la batterie / Cargador suministrado	6 hours
<b>Saída</b> Output / Sortie / Salida	5V/2 A; 12V/10 A
<b>Entrada</b> Input / Entrée / Entrada	15V/1 A
<b>Corrente de arranque</b> Starting current / Courant de démarrage / Corriente de arranque	250 A
<b>Pico de corrente</b> Peak current / Courant crête / Pico de corriente	500 A
<b>Temperatura de operação</b> Operating temperature / Température de fonctionnement / Temperatura de funcionamiento	-20°C - 50°C
<b>Fornecida em</b> / Supplied in / Fournie avec / Se suministrada en	<b>Caja de cartão</b> Card Box / Boîte de carte / Caixa cartão
<b>Código</b> Code / Code / Código	000011001109



**Arranca viaturas até**  
/ Start cars up  
/ Démarrer les voitures  
/ Arranca vehículos hasta

**Gasolina / Gasoline / Essence / Gasolina** ..... **3.500cc**

**Gasóleo / Diesel / Gazole / Gasóleo** ..... **3.000cc**

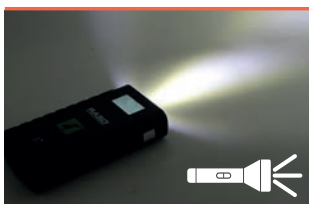
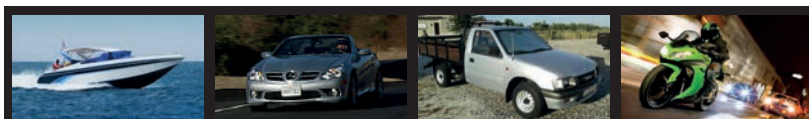

**RASO**  
INNOVATION & TECHNOLOGY





## Mala de Ferramenta PESY

PESY Tool Case / Boîte à outils PESY / Maletin de herramientas PESY

CÓDIGO CODE / CODE / CÓDIGO	DESCRIÇÃO DESCRIPTION / DESCRIPTION / DESCRIPCIÓN	DIMENSÕES DIMENSIONS / DIMENSIONS / DIMENSIONES	PESO WEIGHT / POIDS / PESO	CAPACIDADE (Lts) CAPACITY / CAPACITÉ / CAPACIDAD
000011001100	Mala de Ferramenta PESY SSC1 PESY Tool Case SSC1 / Boîte à outils PESY SSC1 / Maletin de herramientas PESY SSC1	464x335x142	2,15 Kg	9,60
000011001101	Mala de Ferramenta PESY SSC2 PESY Tool Case SSC2 / Boîte à outils PESY SSC2 / Maletin de herramientas PESY SSC2	464x335x212	2,60 Kg	18
000011001102	Mala de Ferramenta PESY SSC3 PESY Tool Case SSC3 / Boîte à outils PESY SSC3 / Maletin de herramientas PESY SSC3	464x335x362	3,75 Kg	37,45
000011001103	Plataforma Metálica SSC/CW Metal Platform SSC/CW / Plate-forme en métal SSC/CW / Plataforma metálica SSC/CW	-	-	-
000011001104	Ninho com 18 divisórias para mala SSC1 Nest with 18 partitions for case SSC1 / Niche avec 18 compartiments pour boîte SSC1 / Nido con 18 separadores para maletin SSC1	-	-	-



**NINHO PARA MALA SSC1**  
Nest for case SSC1  
/ Niche pour boîte SSC1  
/ Nido para maletin SSC1



**Ideal para a Indústria em geral e Manutenção**  
Ideal for General Industry and Maintenance  
Idéal pour l'Industrie en générale et Maintenance  
Ideal para la industria en general y el mantenimiento

**SSC1**

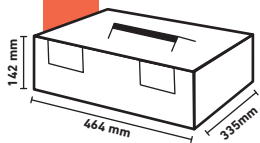

**SSC2**

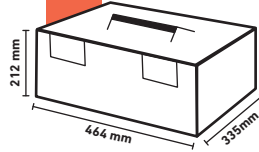

**SSC3**

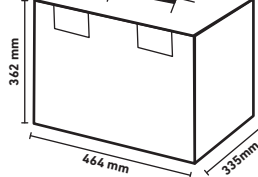

**DIMENSÕES DA MALA**  
Case Sizes  
/ Dimensions de la Boîte  
/ Dimensiones del maletin

**ROBUSTEZ DA MALA**  
Case sturdiness  
/ Robustesse de la Boîte  
/ Robustez del maletin

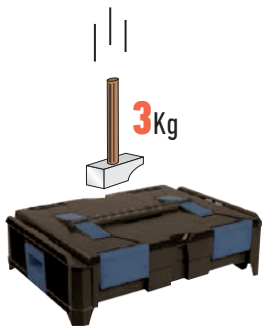

**TESTE DE RESISTÊNCIA AO IMPACTO**  
Impact resistance test  
/ Test de résistance aux chocs  
/ Prueba de resistencia al impacto

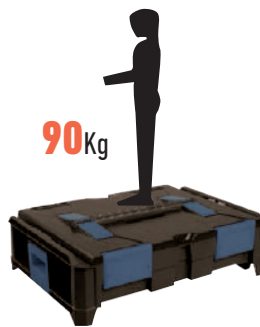

**TESTE DE PRESSÃO**  
Pressure test  
/ Test de pression  
/ Prueba de presión

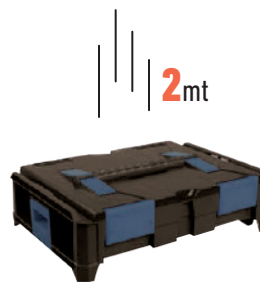

**TESTE DE RESISTÊNCIA À QUEDA**  
Drop resistance test  
/ Test de résistance à la chute  
/ Prueba de resistencia a la caída

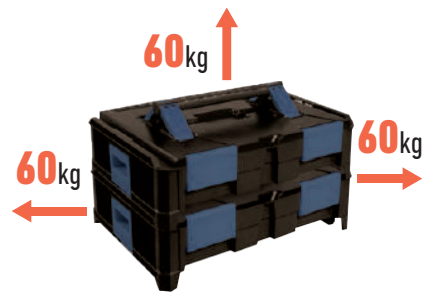

**FECHOS CENTRAIS E LATERAIS**  
Central and side locks  
/ Serrures centrales et latérales  
/ Cierres centrales y laterales

## Caixas Modulares

Modular boxes / Boîtes modulaires / Cajas Modulares

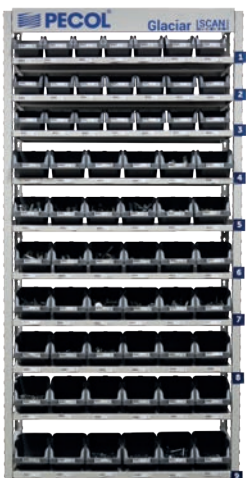

CÓDIGO CODE / CODE / CÓDIGO	DIMENSÕES SIZE / DIMENSIONS / MEDIDA	EMBALAGEM QUANTITY / EMBALLAGE / EMBALAJE
000011000501	125x195x90	60
000011000502	152x245x122	60
000011000503	265x420x177	20
000011000504	310x490x195	12



**Possibilidade de modelar as caixas encaixando-as na vertical por forma a criar um sistema de armazenamento integrado**  
Allow to model the boxes by sliding them vertically in order to create an integrated storage system  
Possibilité de manipuler les boîtes, les positionner verticalement, afin de créer un système de stockage intégré  
Posibilidad de modelar las cajas encajándolas verticalmente con el fin de crear un sistema de almacenamiento integrado



# MANUTENÇÃO E ORGANIZAÇÃO

Maintenance and Organization / Maintenance et Organisation / Mantenimiento y Organización

## Escadas e Escadotes Alumínio

Aluminum Ladder / Échelles et Escabeaux Aluminium / Escaleras Simples y Dobles Alumínio

### Escada Alumínio / Aluminum Ladder / Échelle Aluminium / Escalera Alumínio



CÓDIGO CODE / CODE / CÓDIGO	ALTURA (cm) HEIGHT (cm) / HAUTEUR (cm) / ALTURA (cm)	DEGRAUS STEPS / MARCHES / PELDAÑOS	PESO (Kg) WEIGHT (Kg) / POIDS (Kg) / PESO (Kg)	EMBALAGEM QUANTITY / EMBALLAGE / EMBALAJE
008788011200	200	7	3,6	1
008788011250	250	9	4,6	1
008788011300	300	11	5,5	1



Escada em alumínio com 1,3 mm de espessura e perfil de 61x26mm, disponível nas versões de 7, 9 e 11 degraus para uso industrial

Aluminum ladder with profile 61 x 26mm with 1,3mm thickness. Available in versions with 7, 9 and 11 steps for industrial use

Échelle en aluminium avec une épaisseur de 1,3 mm et profil de 61x26mm, disponible dans les versions de 7, 9 et 11 marches pour usage industriel

Escalera en aluminio con 1,3 mm de espesor y perfil de 61x26mm, disponible en las versiones de 7, 9 y 11 peldaños para uso industrial

### Escadote Alumínio / Aluminum Step Ladder / Escabeau Alumínio / Escalera Doble Alumínio



CÓDIGO CODE / CODE / CÓDIGO	ALTURA (cm) HEIGHT (cm) / HAUTEUR (cm) / ALTURA (cm)	DEGRAUS STEPS / MARCHES / PELDAÑOS	PESO (Kg) WEIGHT (Kg) / POIDS (Kg) / PESO (Kg)	EMBALAGEM QUANTITY / EMBALLAGE / EMBALAJE
008788000800	61	3	2,9	1
008788001000	83	4	4	1
008788001250	105	5	4,6	1
008788001500	126	6	4,6	1



Escadote em alumínio com 1,25 mm de espessura e perfil de 35x20 mm, disponível nas versões de 3, 4, 5 e 6 degraus para uso industrial e doméstico

Aluminum ladder with 35 x 20 mm profile and 1,25 mm thickness. Available in following versions: 3, 4, 5 and 6 steps. For industrial and domestic use

Escabeau en aluminium avec une épaisseur de 1,25 mm et profil de 35x20 mm, disponible dans les versions de 3, 4, 5 et 6 marches pour usage industriel et domestique

Escalera Doble en aluminio con 1,25 mm de espesor y perfil de 35x20 mm, disponible en las versiones de 3, 4, 5 y 6 peldaños para uso industrial y doméstico



### Escada Alumínio Dupla / Aluminum Double Ladder / Échelle Aluminium Double / Escalera Doble Alumínio



CÓDIGO CODE / CODE / CÓDIGO	ALTURA (cm) HEIGHT (cm) / HAUTEUR (cm) / ALTURA (cm)	DEGRAUS STEPS / MARCHES / PELDAÑOS	PESO (Kg) WEIGHT (Kg) / POIDS (Kg) / PESO (Kg)	EMBALAGEM QUANTITY / EMBALLAGE / EMBALAJE
008788021310	313	7	8,6	1
008788021425	425	9	11,6	1
008788021510	509	11	12,8	1



Escada dupla em alumínio com 1,3 mm de espessura e perfil 61x26mm, disponível nas versões de 7, 9 e 11 degraus para uso industrial

Aluminum step ladder with profile 61 x 26 mm and 1,3 mm thickness. Available in versions 7, 9 and 11 steps for industrial use

Échelle double en aluminium avec 1,3 mm d'épaisseur et profil de 61x26mm, disponible dans les versions 7, 9 et 11 marches pour usage industriel

Escalera doble en aluminio con 1,3 mm de espesor y perfil 61x26mm, disponible en las versiones de 7, 9 y 11 peldaños para uso industrial



## Correntes

Chains / Chaînes / Cadenas

Cadena Acero Galvanizado / Chaîne Acier Galvanisé / Galvanized Steel Chain / Corrente Aço Galvanizado

DIN5685A

CÓDIGO CODE / CODE / CÓDIGO	DIMENSÕES SIZE / DIMENSIONS / MEDIDA	KG/METRO KG/METERS   KG/MÈTRE   KG/METRO	METROS POR BOBINE METERS/COIL   MÈTRES PAR BOBINE   METROS POR BOBINA
056851160120	16x12x3	0,165	30
056851190160	19x16x4	0,300	30
056851210200	21x20x5	0,500	25
056851240240	24x24x6	0,730	15
056851320320	32x32x8	1,300	10



### Construção de portões e uso doméstico

Gates and household  
Construction de portails et usage domestique  
Construcción de portones y uso doméstico



Cadena Plástica / Chaîne en plastique / Plastic Chain / Corrente Plástico

CÓDIGO CODE / CODE / CÓDIGO	DIMENSÕES SIZE / DIMENSIONS / MEDIDA	KG/METRO KG/METERS   KG/MÈTRE   KG/METRO	METROS POR BOBINE METERS/COIL   MÈTRES PAR BOBINE   METROS POR BOBINA
001918265500	60x26,5x8	0,095	12



### Indicada para delimitação de espaços

Suitable for area delimitation  
Indiquée pour la délimitation d'espaces  
Indicada para delimitación de espacios





# MANUTENÇÃO E ORGANIZAÇÃO

Maintenance and Organization / Maintenance et Organisation / Mantenimiento y Organización

## Cabos de Aço

Steel Cables / Câbles en Acier / Cables de Acero

DIN3055

Cabo Aço Galvanizado / Galvanized Steel Cable / Câble Acier Galvanisé / Cable Acero Galvanizado



CÓDIGO CODE / CODE / CÓDIGO	DIMENSÕES SIZE / DIMENSIONS / MEDIDA	KG/METRO KG/METERS   KG/MÈTRE   KG/METRO	METROS POR BOBINE / METERS/COIL   MÈTRES PAR BOBINE   METROS POR BOBINA
030551672000	6x7x2	0,0143	100
030551672500	6x7x2,5	0,0224	100
030551673000	6x7x3	0,0322	100
030551674000	6x7x4	0,0572	100
030551675000	6x7x5	0,0894	100

DIN3060

Cabo Aço Galvanizado / Galvanized Steel Cable / Câble Acier Galvanisé / Cable Acero Galvanizado



CÓDIGO CODE / CODE / CÓDIGO	DIMENSÕES SIZE / DIMENSIONS / MEDIDA	KG/METRO KG/METERS   KG/MÈTRE   KG/ METRO	METROS POR BOBINE / METERS/COIL   MÈTRES PAR BOBINE   METROS POR BOBINA
030602619250	6x19x2,5	0,0238	150
030602619300	6x19x3	0,0343	150
030602619400	6x19x4	0,0609	150
030551676000	6x19x6	0,1330	300

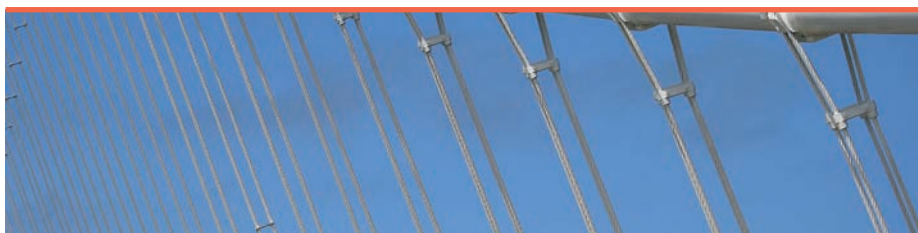

DIN3050

Cabo Aço Inox / Stainless Steel Cable / Câble Acier Inox / Cable Acero Inox



CÓDIGO CODE / CODE / CÓDIGO	DIMENSÕES SIZE / DIMENSIONS / MEDIDA	KG/METRO KG/METERS   KG/MÈTRE   KG/ METRO	METROS POR BOBINE / METERS/COIL   MÈTRES PAR BOBINE   METROS POR BOBINA
030503672000	6x7x2	0,0143	100
030503673000	6x7x3 (250 Mt)	0,0322	100

DIN3050

Cabo Aço Inox / Stainless Steel Cable / Câble Acier Inox / Cable Acero Inox



CÓDIGO CODE / CODE / CÓDIGO	DIMENSÕES SIZE / DIMENSIONS / MEDIDA	KG/METRO KG/METERS   KG/MÈTRE   KG/ METRO	METROS POR BOBINE / METERS/COIL   MÈTRES PAR BOBINE   METROS POR BOBINA
001918367300	6x7x3 (2+1)	0,0198	100
001918367400	6x7x4 (2,5+1,5)	0,0333	100
001918367401	6x7x4 (3+1)	0,0399	100
001918367500	6x7x5	0,0498	100
001918367600	6x7x6	0,0792	100

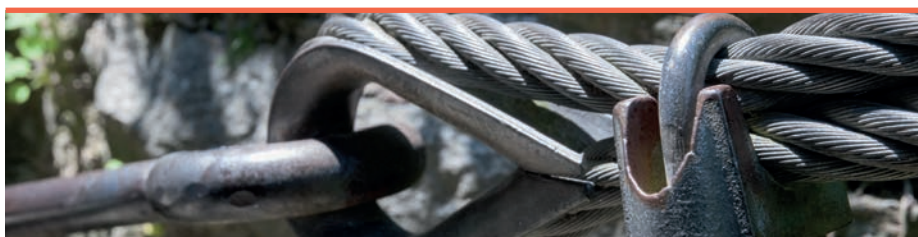



## Terminais

Terminals / Cosses / Terminales

Terminales Aislados / Cosses Pré-isolées / Insulated Terminals / Terminais Isolados

CÓDIGO CODE / CODE / CÓDIGO	TIPO TYPE / TIPO / TIPO	SECÇÃO (mm <sup>2</sup> ) / SECTION (mm) / SECTION (mm) / SECCIÓN (mm)	COR COLOR / COULEUR DE COSSE / COLOR	EMBALAGEM QUANTITY / EMBALLAGE / EMBALAJE
000013210100	RVL 1.25-4	0.5 - 1.5	Vermelho / Red / Rouge / Rojo	50
000013210101	RVL 1.25-5	0.5 - 1.5	Vermelho / Red / Rouge / Rojo	50
000013210102	RVL 1.25-6	0.5 - 1.5	Vermelho / Red / Rouge / Rojo	50
000013210103	RV 2-3	1.5 - 2.5	Azul / Blue / Bleu / Azul	50
000013210104	RVL 2-4	1.5 - 2.5	Azul / Blue / Bleu / Azul	50
000013210105	RVL 2-5	1.5 - 2.5	Azul / Blue / Bleu / Azul	50
000013210106	RV 2-6	1.5 - 2.5	Azul / Blue / Bleu / Azul	50
000013210107	RV 2-8	1.5 - 2.5	Azul / Blue / Bleu / Azul	50
000013210108	RVS 3.5-5	2.5 - 4	Preto / Black / Noir / Negro	50
000013210109	RVL 3.5-5	2.5 - 4	Preto / Black / Noir / Negro	50
000013210110	RV 3.5-6	2.5 - 4	Preto / Black / Noir / Negro	50
000013210111	RV 5.5-6	4 - 6	Amarelo / Yellow / Jaune / Amarilla	50
000013210112	RV 5.5-8	4 - 6	Amarelo / Yellow / Jaune / Amarilla	50
000013210120	SVM 1.25-4	0.5 - 1.5	Vermelho / Red / Rouge / Rojo	50
000013210121	SVS 1.25-5	0.5 - 1.5	Vermelho / Red / Rouge / Rojo	50
000013210122	SV 2-5	1.5 - 2.5	Azul / Blue / Bleu / Azul	50
000013210123	SV 2-6	1.5 - 2.5	Azul / Blue / Bleu / Azul	50
000013210124	SV 3.5-5	2.5 - 4	Preto / Black / Noir / Negro	50
000013210125	SV 5.5-5	4 - 6	Amarelo / Yellow / Jaune / Amarilla	50
000013210130	BV 1.25	0.5 - 1.5	Vermelho / Red / Rouge / Rojo	50
000013210131	BV 2	1.5 - 2.5	Azul / Blue / Bleu / Azul	50
000013210132	BV 5.5	4 - 6	Amarelo / Yellow / Jaune / Amarilla	50
000013210140	E1008	1	Vermelho / Red / Rouge / Rojo	50
000013210141	E1508	1.5	Preto / Black / Noir / Negro	50
000013210142	E2508	2.5	Cinza / Grey / Gris / Gris	50
000013210143	E4009	4	Laranja / Orange / Orange / Naranja	50
000013210144	E6012	6	Verde / Green / Vert / Verde	50
000013210145	E10-12	10	Castanho / Brown / Marron / Marrón	50

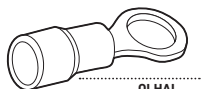

OLHAL

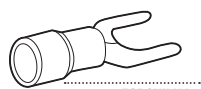

FORQUILHA

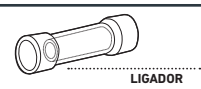

LIGADOR

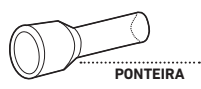

PONTEIRA



OLHAL



FORQUILHA



PONTEIRA



LIGADOR



## Barra Junção

Cable Connector Strips / Barrette de Connexion / Clema

CÓDIGO CODE / CODE / CÓDIGO	DIMENSÕES SIZE / DIMENSIONS / MEDIDA	AMPERES AMPERES / AMPERES / AMPERIOS	EMBALAGEM QUANTITY / EMBALLAGE / EMBALAJE
000013210000	4mm <sup>2</sup>	3 A	10



**Eletricistas | Manutenção em geral**  
Electricians | General maintenance  
Électricien | Maintenance en générale  
Electricistas | Mantenimiento en general

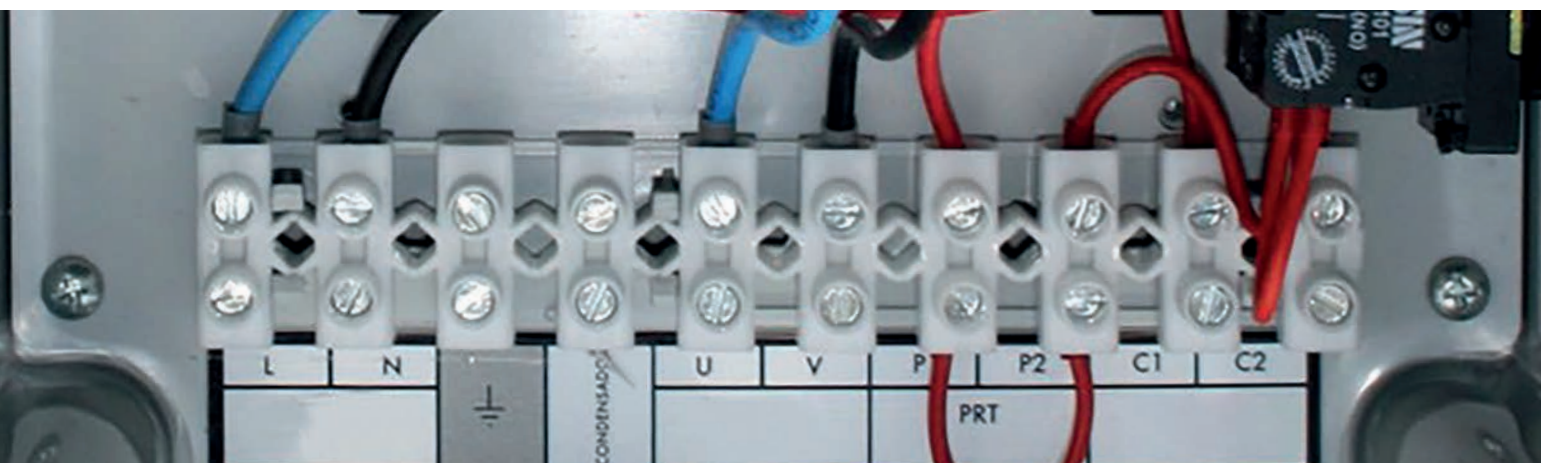
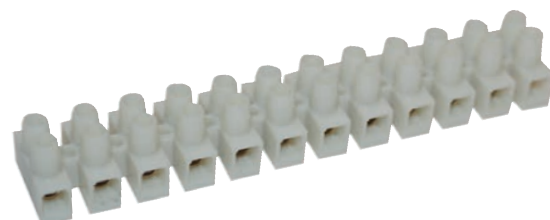



# MANUTENÇÃO E ORGANIZAÇÃO

Maintenance and Organization / Maintenance et Organisation / Mantenimiento y Organización

## Cadeados

Padlocks / Cadenas / Candado

### Cadeado Estanque Arco Longo

Sealed Padlock Long Arch / Cadenas d'extérieure anse longue / Candado estanco con arco largo



### Cadeado Estanque Arco Normal

Sealed Padlock Normal Arch / Cadenas d'extérieure / Candado estanco con arco normal



CÓDIGO CODE / CODE / CÓDIGO	TAMANHO SIZE / DIMENSION / TAMAÑO	EMBALAGEM QUANTITY / EMBALLAGE / EMBALAJE
000085000530	30 mm	12
000085000550	50 mm	12

**Arco longo | Impermeável | Possui 3 chaves em aço**  
 Long arch | waterproof | 3 keys in steel included  
 Arc Long | Imperméable | Il dispose de 3 touches en acier  
 Arco Largo | Impermeable | Cuenta con 3 llaves de acero

CÓDIGO CODE / CODE / CÓDIGO	TAMANHO SIZE / DIMENSION / TAMAÑO	EMBALAGEM QUANTITY / EMBALLAGE / EMBALAJE
000085000430	30 mm	12
000085000440	40 mm	12
000085000450	50 mm	12

**Arco normal | Impermeável | Possui 3 chaves em aço**  
 Normal arch | waterproof | 3 keys in steel included  
 Arc Normal | Imperméable | Il dispose de 3 touches en acier  
 Arco Normal | Impermeable | Cuenta con 3 llaves de acero

### Cadeado Arco Longo

Padlock Long Arch / Cadenas anse longue / Candado Arco Longo



CÓDIGO CODE / CODE / CÓDIGO	TAMANHO SIZE / DIMENSION / TAMAÑO	EMBALAGEM QUANTITY / EMBALLAGE / EMBALAJE
000085000220	20 mm	10
000085000225	25 mm	6
000085000230	30 mm	6
000085000240	40 mm	6
000085000250	50 mm	6
000085000260	60 mm	6

**Arco longo | Corpo em latão e acabamento areado | Possui 3 chaves**  
 Long arch | Brass body and sandblasted finishing | 3 keys included  
 Anse longue | Corps en laiton | Comprend 3 clés  
 Arco largo | Cuerpo en latón y acabado arenado | Cuenta con 3 llaves

### Cadeado Arco Normal

Padlock Normal Arch / Cadenas anse normal / Candado Arco Normal



CÓDIGO CODE / CODE / CÓDIGO	TAMANHO SIZE / DIMENSION / TAMAÑO	EMBALAGEM QUANTITY / EMBALLAGE / EMBALAJE
000085000120	20 mm	12
000085000125	25 mm	6
000085000130	30 mm	6
000085000135	35 mm	6
000085000140	40 mm	6
000085000145	45 mm	6
000085000150	50 mm	6
000085000160	60 mm	6
000085000170	70 mm	6

**Arco normal | Corpo em latão e acabamento areado | Possui 3 chaves**  
 Normal arch | Brass body and sandblasted finishing | 3 keys included  
 Anse normal | Corps en laiton | Comprend 3 clés  
 Arco normal | Cuerpo en latón y acabado arenado | Cuenta con 3 llaves

### Cadeado Retangular

Rectangular Padlock / Cadenas Rectangulaires / Candado rectangular



CÓDIGO CODE / CODE / CÓDIGO	TAMANHO SIZE / DIMENSION / TAMAÑO	EMBALAGEM QUANTITY / EMBALLAGE / EMBALAJE
000085000350	50 mm	5
000085000360	60 mm	5
000085000370	70 mm	5

**Fecho com mola | Corpo em latão e acabamento areado | Possui 3 chaves**  
 Closure with spring | Brass body and sandblasted finishing | 3 keys included  
 Verrouillage à ressort | Corps en laiton | Comprend 3 clés  
 Cierre con muelle | Cuerpo en latón y acabado arenado | Cuenta con 3 llaves

### Cadeado com Código

Padlock With Code / Cadenas à combinaison / Candado con código



CÓDIGO CODE / CODE / CÓDIGO	TAMANHO SIZE / DIMENSION / TAMAÑO	EMBALAGEM QUANTITY / EMBALLAGE / EMBALAJE
000085000020	20 mm	12
000085000030	30 mm	12

**Combinação de 3 dígitos | Corpo em latão e acabamento areado**  
 Code with 3 digits combination | Brass body and sandblasted finishing  
 Combinaison de 3 chiffres | Corps en laiton  
 Combinación de 3 dígitos | Cuerpo en latón y acabado arenado



# FERRAGENS

*FURNITURE HARDWARE  
QUINCAILLERIE DU MEUBLE  
HERRAJES*



# FERRAGENS

Furniture Hardware / Quincaillerie du Meuble / Herrajes

## Dobradiças

Hinge / Charnières / Bisagra



### DCSC

**Dobradiça c/ Duas vias Clip-on c/Soft-Close**  
/ Clip-on Soft-closing Hinge  
/ Charnières Clip-On a/ Soft-Close  
/ Bisagra c/ Dos Vías Clip-On c/ Soft-Close

16

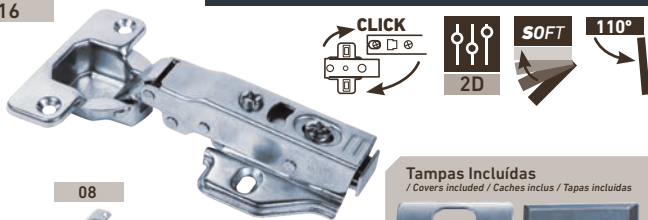

08

00

**Tampas Incluídas**  
/ Covers included / Caches inclus / Tapas incluidas

CÓDIGO CODE / CODE / CÓDIGO	REF	EMBALLAGEM QUANTITY / EMBALLAGE / EMBALAJE
004201161101	16	100
004201081101	08	100
004201001101	00	100

### DCSC 3D

**Dobradiça Clip-on c/Soft-Close e Ajustação 3D**  
/ Clip-on Soft-closing System with 3D Adjustment Hinge  
/ Charnière Clip-On a/ Soft-Close et Réglage 3D  
/ Bisagra Clip-On c/ Soft-Close y Afinación 3D

16

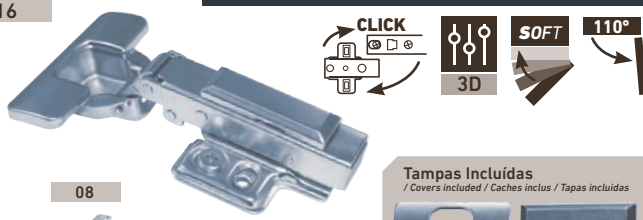

08

00

**Tampas Incluídas**  
/ Covers included / Caches inclus / Tapas incluidas

CÓDIGO CODE / CODE / CÓDIGO	REF	EMBALLAGEM QUANTITY / EMBALLAGE / EMBALAJE
004201161116	16	100
004201161108	08	100
004201101100	00	100

### DC3D2

**Dobradiça c/ Clip-on 110° c/ Calço 3D**  
/ Clip-on Hinge with 3D Adjustment hinge  
/ Charnières Clip-On 110° a/ Embase 3D  
/ Bisagra Clip-On 110° c/ Soporte 3D

16



08

00

**Tampa Incluída**  
/ Cover included / Caches inclus / Tapa incluida

CÓDIGO CODE / CODE / CÓDIGO	REF	EMBALLAGEM QUANTITY / EMBALLAGE / EMBALAJE
004201116110	16	250
004201108110	08	250
004201100110	00	250

### DA

**Dobradiças Aparafusar c/ Calço**  
/ Slide-on Hinge  
/ Charnière à Visser a/ Embase  
/ Bisagra Atornillar c/ Soporte

16

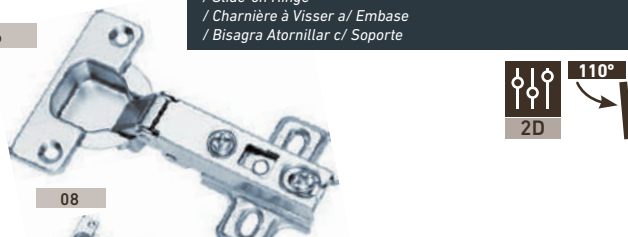

08

00

**Calço**  
/ Soporte/ Embase  
/ Soporte  
H=0

CÓDIGO CODE / CODE / CÓDIGO	REF	EMBALLAGEM QUANTITY / EMBALLAGE / EMBALAJE
004202161100	16	250
004202081100	08	250
004202001100	00	250
004202991100	H=0	250

### DC2

**Dobradiça c/ Clip-on 110° c/ Calço**  
/ Clip-on Hinge  
/ Charnière Clip-On 110° a/ Embase  
/ Bisagra Clip-On 110° c/ Soporte

16



08

00

**Tampa Incluída**  
/ Cover included / Caches inclus / Tapa incluida

CÓDIGO CODE / CODE / CÓDIGO	REF	EMBALLAGEM QUANTITY / EMBALLAGE / EMBALAJE
004204161101	16	250
004204081101	08	250
004204001101	00	250

135



CÓDIGO CODE / CODE / CÓDIGO	EMBALLAGEM QUANTITY / EMBALLAGE / EMBALAJE
004202011350	200

16-175



CÓDIGO CODE / CODE / CÓDIGO	EMBALLAGEM QUANTITY / EMBALLAGE / EMBALAJE
004202161750	1





## Corrediças

Slides / Coulisses / Correderas

### Corrediça Euro-Slide c/Self Closing

Self Closing Euro-Slide / Coulisse Euro-Slide avec Self Closing / Corredera Euro-Slide con Self Closing

### EURO-SLIDE

DIMENSÕES / SIZE / DIMENSIONS / MEDIDA	CÓDIGO / CODE / CODE / CÓDIGO			EMBALAGEM / QUANTITY / EMBALLAGE / EMBALAJE
	○	●	●	
250	012901002500	012902002500	012903002500	25+25
300	012901003000	012902003000	012903003000	25+25
350	012901003500	012902003500	012903003500	25+25
400	012901004000	012902004000	012903004000	25+25
450	012901004500	012902004500	012903004500	25+25
500	012901005000	012902005000	012903005000	25+25
550	012901005500	012902005500	012903005500	25+25
600	012901006000	012902006000	012903006000	25+25



### Corrediça de Esferas

Ball Bearing Slides / Coulisses à Billes / Correderas Esferas

### CE

#### CEP35



CÓDIGO CODE / CODE / CÓDIGO	DIMENSÕES SIZE / DIMENSIONS / MEDIDA	EMBALAGEM QUANTITY / EMBALLAGE / EMBALAJE
013600002500	250	25
013600003500	350	25
013600005000	500	25
013600005500	550	25

#### CET35



CÓDIGO CODE / CODE / CÓDIGO	DIMENSÕES SIZE / DIMENSIONS / MEDIDA	EMBALAGEM QUANTITY / EMBALLAGE / EMBALAJE
013401002500	250	20
013401003000	300	20
013401003500	350	20
013401004000	400	20
013401004500	450	20
013401005000	500	20

#### CET45



CÓDIGO CODE / CODE / CÓDIGO	DIMENSÕES SIZE / DIMENSIONS / MEDIDA	EMBALAGEM QUANTITY / EMBALLAGE / EMBALAJE
013400002500	250	15
013400003000	300	15
013400003500	350	15
013400004000	400	15
013400004500	450	15
013400005000	500	15

#### CET45S



CÓDIGO CODE / CODE / CÓDIGO	DIMENSÕES SIZE / DIMENSIONS / MEDIDA	EMBALAGEM QUANTITY / EMBALLAGE / EMBALAJE
013501003000	300	10
013501003500	350	10
013501004000	400	10

#### CET45S



CÓDIGO CODE / CODE / CÓDIGO	DIMENSÕES SIZE / DIMENSIONS / MEDIDA	EMBALAGEM QUANTITY / EMBALLAGE / EMBALAJE
013502003500	350	10
013502004000	400	10
013502004500	450	10
013502005000	500	10
013502005500	550	10
013502006000	600	10
013502006500	650	10
013502007000	700	10



## Corrediças

Slides / Coulisses / Correderas

CO

### Corrediças Ocultas

Undermount Drawer Slides / Coulisses Occultes / Correderas Ocultas

#### COPPT



CÓDIGO CODE / CODE / CÓDIGO	DIMENSÕES SIZE / DIMENSIONS / MEDIDA	EMBALAGEM QUANTITY / EMBALLAGE / EMBALAJE
014001003000	300	10
014001003500	350	10
014001004000	400	10
014001004500	450	10
014001005000	500	10

#### COPSC



CÓDIGO CODE / CODE / CÓDIGO	DIMENSÕES SIZE / DIMENSIONS / MEDIDA	EMBALAGEM QUANTITY / EMBALLAGE / EMBALAJE
014100003000	300	10
014100003500	350	10
014100004000	400	10
014100004500	450	10
014100005000	500	10

#### COPSCF



CÓDIGO CODE / CODE / CÓDIGO	DIMENSÕES SIZE / DIMENSIONS / MEDIDA	EMBALAGEM QUANTITY / EMBALLAGE / EMBALAJE
013801003000	300	10
013801003500	350	10
013801004000	400	10
013801004500	450	10
013801005000	500	10

#### COTSCF



CÓDIGO CODE / CODE / CÓDIGO	DIMENSÕES SIZE / DIMENSIONS / MEDIDA	EMBALAGEM QUANTITY / EMBALLAGE / EMBALAJE
013901003500	350	10
013901004000	400	10
013901004500	450	10
013901005000	500	10
013901005500	550	10



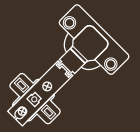

# G-STARK SLIM

**NOVO**  
Innovation / Nouveauté / Novedad

## KIT GAVETA EXTRAÇÃO TOTAL C/ SOFT-CLOSE STARK-SLIM

/ Total Extraction Drawer Kit w/Soft-Close STARK-SLIM / Kit Tirour Extraction Totale avec Soft-Close STARK-SLIM / Kit Gaveta Extracción Total con Soft-Close STARK-SLIM

**PESO SUPORTADO**

/ Load capacity / Capacité de charge / Capacidad de carga

**40 KG**

**DURABILIDADE**

/ Durability / Durabilité / Durabilidad

**80.000 CICLOS**

/ Cycles / Cycles / Ciclos

**ESPESSURA LATERAL RETA**

/ Straight Side Thickness / Épaisseur Latérale Droite / Espesor Lateral Recto

**13 MM**

Trata-se de um Kit que permite fazer uma gaveta ou gavetão de extração total com Soft-Close, com a particularidade da lateral ter somente 13mm de espessura, dando um design inovador e maior aproveitamento do espaço interior. A robustez das corredeiras e a suavidade do seu deslizamento torna esta gaveta única no mercado. Disponível nas cores Branca e Cinza.

/ It is a Kit that allows to make a drawer or a pull-out of total extraction with Soft-Close, with the particularity of the side being only 13 mm thick, providing an innovative design and greater use of the interior space. The robustness of the slides and the smoothness of their sliding makes this drawer unique in the market. Available in White and Gray colours / Il s'agit d'un Kit qui permet de réaliser un tiroir ou un grand tiroir d'extraction totale avec Soft-Close, ayant la particularité que le côté n'a que 13 mm d'épaisseur, avec un design innovant et une plus grande utilisation de l'espace intérieur. La robustesse des glissières et la douceur de glissement rendent ce tiroir unique sur le marché. Disponible en Blanc et Gris / Se trata de un kit que permite hacer un cajón o gavetón de extracción total con Soft-Close, con la particularidad del lateral tener sólo 13 mm de espesor, dando un diseño innovador y mayor aprovechamiento del espacio interior. La robustez de las correderas y la suavidad de su deslizamiento hacen de este cajón único en el mercado. Disponible en los colores Blanco y Gris

CÓDIGO CODE / CODE / CÓDIGO	DESCRIÇÃO DESCRIPTION / DESCRIPCIÓN	DIMENSÕES / SIZE / DIMENSIONS / MEDIDA	COR COLOR / COULEUR / COLOR	EMBALAGEM / QUANTITY / EMBALLAGE / EMBALAJE
004218089500	Kit Gaveta c/ Soft-Close STARK-Slim STARK-Slim Soft-Close Drawer Kit / Ensemble Tiroir avec Soft-Close STARK-Slim / Kit Cajón con Soft-Close STARK-Slim	500 mm	Cinza Grey / Gris / Gris	1
004218164400	1 Gavetão 164 mm c/ Soft-Close STARK-Slim 1 Pull-Out of 164 mm w/Soft-Close STARK-Slim / 1 Grand Tiroir 164 mm avec Soft-Close STARK-Slim / 1 Gavetón 164 mm c/Soft-Close STARK-Slim	400 mm	Cinza Grey / Gris / Gris	1



**Lateral reta com somente 13 mm de espessura | Gaveta robusta e com um deslizamento suave**

/ Straight side with only 13 mm of thickness | Robust drawer and with a smooth sliding  
/ Côté droit avec seulement 13 mm d'épaisseur | Tiroir solide avec un glissement doux  
/ Lateral recto con sólo 13 mm de espesor | Cajón robusto y con un deslizamiento suave

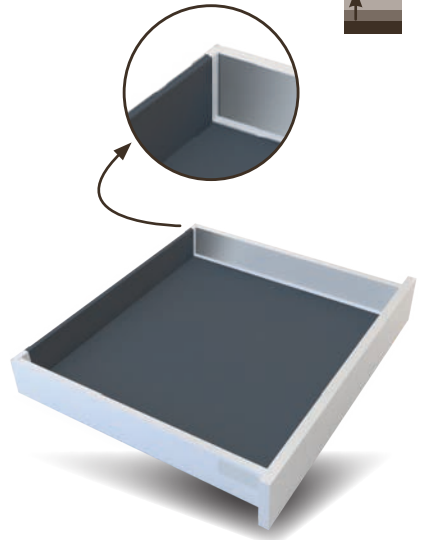

Disponível gavetão com 164 e 204 mm de altura / Pull-out available with 164 and 204 mm of height / Disponible grand tiroir avec 164 et 204 mm d'hauteur / Disponible gavetón con 164 y 204 mm de altura



**PESO SUPORTADO**

/ Load capacity / Capacité de charge / Capacidad de carga

**40 KG**

**DURABILIDADE**

/ Durability / Durabilité / Durabilidad

**80.000 CICLOS**

/ Cycles / Cycles / Ciclos



**Deslizar silencioso | Máxima estabilidade da lateral | Tecnologia sincronizada das corredeiras, sem vibração | Soft-Close robusto e sincronizado | Certificação SGS e TÜV**

/ Sliding silent | Maximum lateral stability | Synchronized slides technology, without vibration | Robust and synchronized soft-closing | SGS and TÜV certification

/ Glissement silencieux | Maximum de stabilité latérale | Technologie synchronisée des coulisses sans vibration | Soft-close robuste et synchronisée | Certification SGS et TÜV

/ Deslice silenciosa | Máxima estabilidad lateral | Tecnología sincronizada de las correderas, sin vibración | Amortiguador robusto y sincronizado | Certificación SGS y TÜV

## GAVETA / Drawer / Tiroir / Cajón G-STARK

**ExtT** **SOFT**

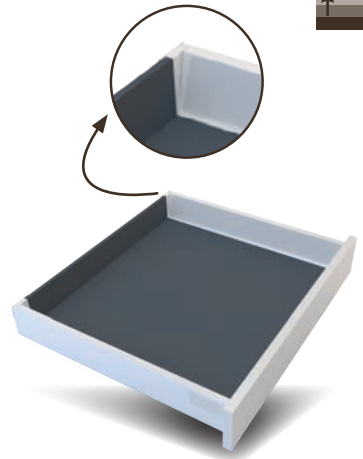

DIMENSÕES / SIZE / DIMENSIONS / MEDIDA	CÓDIGO / CODE / CODE / CÓDIGO		EMBALAGEM / QUANTITY / EMBALLAGE / EMBALAJE
350	004211633502	004211633500	10
400	004211634002	004211634000	10
450	004211634502	004211634500	10
500	004211635003	004211635000	10
550	-	004211635500	10

**GAMA DISPONÍVEL** / Available range / Gamme disponible / Gama disponible

**GAVETÃO G-STARK**

GAVETA G-STARK + KIT GAVETÃO

**GAVETA INTERIOR G-STARK**

GAVETA G-STARK + PAINEL FRONTAL

**GAVETÃO INTERIOR G-STARK**

GAVETA G-STARK + KIT GAVETÃO + PAINEL FRONTAL

**NOVIDADE**  
**GAVETÃO BARRA RETANGULAR G-STARK**

GAVETA G-STARK + KIT GAVETÃO BARRA RETANGULAR

**NOVIDADE**  
**GAVETÃO INTERIOR BARRA RETANGULAR G-STARK**

GAVETA G-STARK + KIT GAVETÃO BARRA RETANGULAR + PAINEL FRONTAL

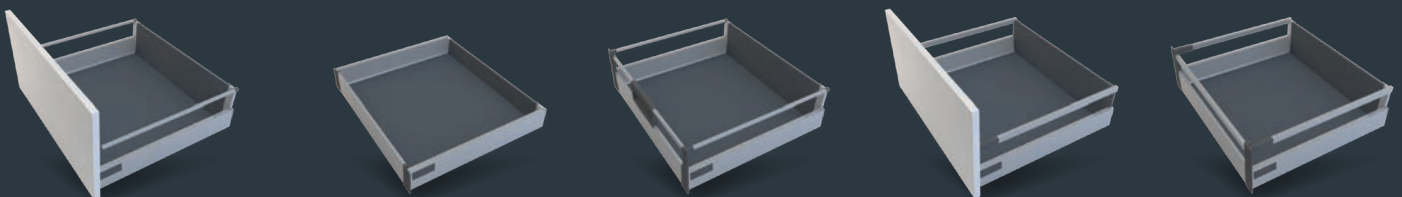



# FERRAGENS

Furniture Hardware / Quincaillerie du Meuble / Herrajes

## Niveladores

Hanging Brackets / Suspension Réglable / Niveladores

NC804.16

### Niveladores

Hanging Brackets / Suspension Réglable / Niveladores

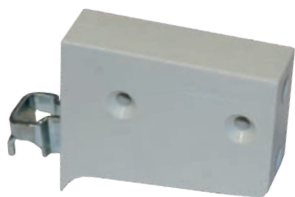

CÓDIGO / CODE / CODE / CÓDIGO		EMBALAGEM / QUANTITY / EMBALLAGE / EMBALAJE
○	●	
004396000035	004396000036	25

NC806

### Niveladores

Hanging Brackets / Suspension Réglable / Niveladores

NC806.14

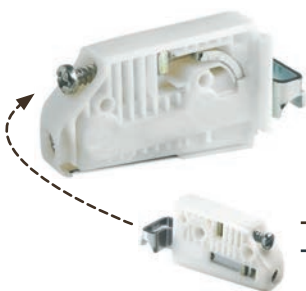

CÓDIGO / CODE / CODE / CÓDIGO		EMBALAGEM / QUANTITY / EMBALLAGE / EMBALAJE
DIREITO / RIGHT / DROIT / DERECHA	ESQUERDO / LEFT / GAUCHE / IZQUIERDA	
004396000002	004396000003	25

NC806.22



CÓDIGO / CODE / CODE / CÓDIGO		EMBALAGEM / QUANTITY / EMBALLAGE / EMBALAJE
DIREITO / RIGHT / DROIT / DERECHA	ESQUERDO / LEFT / GAUCHE / IZQUIERDA	
004396000004	004396000005	25

NC806T - TAMPA P/ NC806

Lid for NC806 / Cache p/NC806 / Tapa p/NC806



CÓDIGO / CODE / CODE / CÓDIGO		EMBALAGEM / QUANTITY / EMBALLAGE / EMBALAJE
DIREITO / RIGHT / DROIT / DERECHA	ESQUERDO / LEFT / GAUCHE / IZQUIERDA	
●	○	
004396000007	004396000008	25
○	●	
004396000009	004396000010	25
●	○	
004396000011	004396000012	25
○	●	
004396000030	004396000031	25

NC807

### Niveladores

Hanging Brackets / Suspension Réglable / Niveladores

NC807 / NC807.02

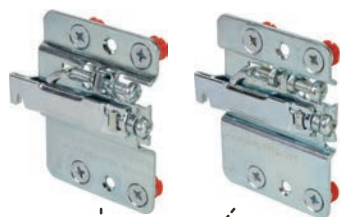

CÓDIGO / CODE / CODE / CÓDIGO		EMBALAGEM / QUANTITY / EMBALLAGE / EMBALAJE
DIREITO / RIGHT / DROIT / DERECHA	ESQUERDO / LEFT / GAUCHE / IZQUIERDA	
807	807.02	
004396000015	004396000016	10
004396000044	004396000045	10

NC897 - SUPORTE P/ NC807

Support for NC807 / Support p/NC807 / Soporte p/NC807



CÓDIGO / CODE / CODE / CÓDIGO		EMBALAGEM / QUANTITY / EMBALLAGE / EMBALAJE
004396000022		10

NC807T - TAMPA P/ NC807

Lid for NC807 / Cache p/NC807 / Tapa p/NC807



CÓDIGO / CODE / CODE / CÓDIGO		EMBALAGEM / QUANTITY / EMBALLAGE / EMBALAJE
DIREITO / RIGHT / DROIT / DERECHA	ESQUERDO / LEFT / GAUCHE / IZQUIERDA	
○	●	
004396000017	004396000018	10
●	○	
004396000026	004396000027	10
○	●	
004396000028	004396000029	10



NC874

### Barra Suporte - 40 x 5 (2000 mm)

Support bar / Rail de Support / Barra Soporte



CÓDIGO / CODE / CODE / CÓDIGO		DIMENSÕES / SIZE / DIMENSIONS / MEDIDA	EMBALAGEM / QUANTITY / EMBALLAGE / EMBALAJE
004396000021		2000	1

NC806 | NC807 | NC818





## Niveladores

Hanging Brackets / Suspension Réglable / Niveladores

### KIT Niveladores 3D OCULTO

Hidden 3D Hanging Bracket KIT / Kit Suspension 3D Occulte / Kit Nivelador 3D Oculto



### NC821



CÓDIGO / CODE / CODE / CÓDIGO	EMBALAGEM / QUANTITY / EMBALLAGE / EMBALAJE
00439600024	1

### Niveladores p/ Móveis

Cabinet Hanging Brackets for furniture / Suspensions pour meubles / Nivelador para Muebles

### NM300

#### NM300.A2



CÓDIGO / CODE / CODE / CÓDIGO	EMBALAGEM / QUANTITY / EMBALLAGE / EMBALAJE
004397001008	20

#### NM300.Z2

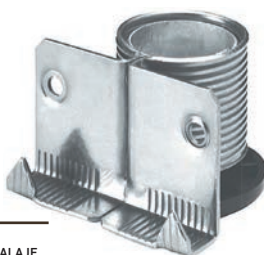

CÓDIGO / CODE / CODE / CÓDIGO	EMBALAGEM / QUANTITY / EMBALLAGE / EMBALAJE
004397001009	20

### Niveladores p/ Móveis

Cabinet Hanging Brackets for furniture / Suspensions pour meubles / Nivelador para Muebles

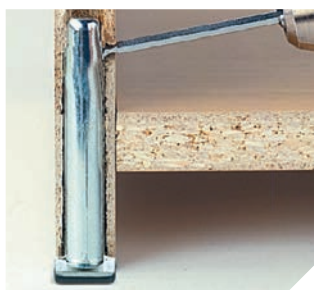

CÓDIGO / CODE / CODE / CÓDIGO	EMBALAGEM / QUANTITY / EMBALLAGE / EMBALAJE
004397001010	20

### NM306.05



### Niveladores

Hanging Bracket / Suspension Réglable / Niveladores



CÓDIGO / CODE / CODE / CÓDIGO	EMBALAGEM / QUANTITY / EMBALLAGE / EMBALAJE	
8 mm DIREITO / RIGHT / DROIT / DERECHA	004396000032	25
10 mm ESQUERDO / LEFT / GAUCHE / IZQUIERDA	004396000033	25
	004396000013	25
	004396000014	25

### NC818.32

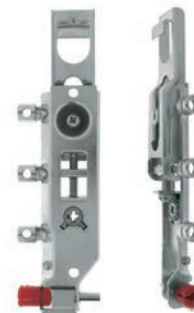

### Niveladores p/ Móveis

Cabinet Hanging Brackets for furniture / Suspensions pour meubles / Nivelador para Muebles

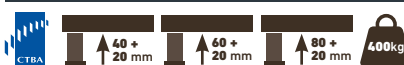

CÓDIGO / CODE / CODE / CÓDIGO	EMBALAGEM / QUANTITY / EMBALLAGE / EMBALAJE	
NM308.04.90	004397001006	20
NM308.06.90	004397001003	20
NM308.08.90	004397001005	20



NM 308 P - Parafuso / Screw / Vis / Tornillo Ø12 x 35 mm

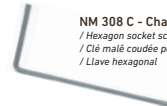

NM 308 C - Chave Sextavada / Hexagon socket screw key / Clé mâle coudée pour vis a six pans creux / Llave hexagonal

NM 308 P	004397001004	20
NM 308 C	004397001007	1

### NM308.04/06/08.90



### Pé Nivelador de Cozinha

Kitchen Hanging Bracket Foot / Pied Réglable de Cuisine / Pata Niveladora Cocina



CÓDIGO / CODE / CODE / CÓDIGO	EMBALAGEM / QUANTITY / EMBALLAGE / EMBALAJE	
100	004397001000	100
120	004397001013	100
150	004397001014	100

### PC7-PRO



Clip p/ PVC / Clip for PVC / Clip p/ PVC / Clip p/ PVC



Encaixe p/ clip Liso / Fitting for flat clip / Emboilage p/ clip Lisse / Encaje p/ clip Liso



Clip Liso / Flat clip / Clip Lisse / Clip Liso



Base c/ e s/ bucha / Base w/ or w/o bushing / Base a/ et s/ cheville / Base c/ y s/ tico

CÓDIGO / CODE / CODE / CÓDIGO	CÓDIGO / CODE / CODE / CÓDIGO	CÓDIGO / CODE / CODE / CÓDIGO	CÓDIGO / CODE / CODE / CÓDIGO
004397001002	004397001012	004397001011	004397001001
EMBALAGEM / QUANTITY / EMBALLAGE / EMBALAJE	EMBALAGEM / QUANTITY / EMBALLAGE / EMBALAJE	EMBALAGEM / QUANTITY / EMBALLAGE / EMBALAJE	EMBALAGEM / QUANTITY / EMBALLAGE / EMBALAJE
100	100	100	100



## Amortecedores + Fechos Tic-Tac

Buffers + Push to Open / Amortisseur + Fermetures Tic-Tac / Amortiguador + Cierres Tic Tac

### BFTT-PRO

**Amortecedor + Tic-Tac (2 em 1)**  
/ Buffer + Push to Open (2 in 1) / Amortisseur + Tic-Tac (2 en 1)  
/ Amortiguador + Tic Tac (2 en 1)



### BFTT-A1

### BFTT-A2

REF	CÓDIGO CODE / CODE / CÓDIGO	EMBALAGEM QUANTITY / EMBALLAGE / EMBALAJE
BFTT-PRO	004205600000	1
BFTT-A1	004205600001	1
BFTT-A2	004205600002	1



**1º Sistema do Mercado (não elétrico) que une Soft-Close (amortecedor) e Tic-Tac num único produto | Compatível com todo o tipo de correijas do Mercado**  
/ First market system (non-electric) uniting bumper and push-plus in a single product | Compatible with all types of market slides

1º Système du marché (non electric) qui unit soft-close et TIC-TAC sur un même produit | Compatible avec tous les types de coulisses du marché

Primer sistema de mercado (no eléctrico) que une amortiguador y TIC-TAC en un solo producto | Compatible con todos los tipos de correderas de mercado

### BF18

**Amortecedor**  
/ Sliding Door Buffer / Amortisseur / Amortiguador



### BF18-A1

REF	CÓDIGO CODE / CODE / CÓDIGO	EMBALAGEM QUANTITY / EMBALLAGE / EMBALAJE
BF18 - 25kg	004205401000	40
BF18 - 40kg	004205302000	20
BF18 - 60kg	004205302060	20
BF18 - A1	004205500000	40

### BF20

**Amortecedor**  
/ Sliding Door Buffer / Amortisseur / Amortiguador



### BF20-A3

REF	CÓDIGO CODE / CODE / CÓDIGO	EMBALAGEM QUANTITY / EMBALLAGE / EMBALAJE
BF20 - 60kg	004205301000	1
BF20 - 80kg	004205303000	1
BF20 - 100kg	004205305000	1
BF20-A3	004205520000	1

### BF-01 PRO



### BF-01A

**Amortecedor**  
/ Buffer / Amortisseur / Amortiguador



### BF-01 PRO

### BF-01 PRO + BF-01A

REF	CÓDIGO CODE / CODE / CÓDIGO	EMBALAGEM QUANTITY / EMBALLAGE / EMBALAJE
BF-01 PRO	004205000000	100
BF-01A	004205000001	100

### BF11 - PRO

**Fechos Tic-Tac**  
/ Push to Open / Fermetures Tic-Tac / Cierres Tic Tac



### F11-PRO 20 / 40 mm



### F11-PRO 20 / 40 mm Mag.



REF	CÓDIGO CODE / CODE / CÓDIGO	EMBALAGEM QUANTITY / EMBALLAGE / EMBALAJE
	004222110001	100
F11-20	004222110006	100
	004222110007	100
F11-20	004222110008	100
	004222110002	25
F11-40	004222110009	100
	004222110004	25
F11-40	004222110010	100

### BF12 - PRO

**Fechos Tic-Tac**  
/ Push to Open / Fermetures Tic-Tac / Cierres Tic Tac



### F12-PRO 20 / 40 mm



### F12-PRO 40 mm Mag.

REF	CÓDIGO CODE / CODE / CÓDIGO	EMBALAGEM QUANTITY / EMBALLAGE / EMBALAJE
F12-20	004222110012	100
F12-40	004222110003	100
F12-40	004222110005	100

### F30

**Fechos**  
/ Lock / Fermetures / Cierres

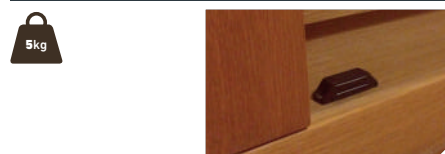

REF	CÓDIGO CODE / CODE / CÓDIGO	EMBALAGEM QUANTITY / EMBALLAGE / EMBALAJE
F30	004222300000	12
	004222310000	12

### F40 - PRO

**Fechos**  
/ Lock / Fermetures / Cierres



CÓDIGO CODE / CODE / CÓDIGO	EMBALAGEM QUANTITY / EMBALLAGE / EMBALAJE
004222320000	12

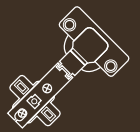

Lamello

Lamello

Lamello / Lamello / Lamello

**Fresadora Zeta - KIT p/ Sistema P**

Zeta Milling Machine - KIT for P System / Zeta P2-Set Machine / Engalietadora Zeta - KIT p/ Sistema P

**ZETA P2**



**800 W | 9.000 rpm**



**VIDEO DEMONSTRAÇÃO**  
Demonstration video  
vídeo de demonstración  
vídeo de demostración



**CÓDIGO**  
/CODE / CODE / CÓDIGO  
00424000207

**EMBALAGEM**  
/ QUANTITY / EMBALLAGE / EMBALAJE  
1



0:30



1:05



1:35



1:45

**SISTEMAS DE UNIÃO / Joint System / Système d'Assemblage / Sistema de Unión**

**Clamex P14**



**VIDEO DEMONSTRAÇÃO**  
Demonstration video  
vídeo de demonstración  
vídeo de demostración



CÓDIGO /CODE / CODE / CÓDIGO	EMBALAGEM / QUANTITY / EMBALLAGE / EMBALAJE
004240000140	100
004240000141	300
004240000142	1000

**Clamex P14 CNC**



CÓDIGO /CODE / CODE / CÓDIGO	EMBALAGEM / QUANTITY / EMBALLAGE / EMBALAJE
<b>A+B</b> 004240000242	100 (100A+100B)
<b>A</b> 004240000231	2000
<b>B</b> 004240000232	2000

**Clamex PMedius 14/10**



**VIDEO DEMONSTRAÇÃO**  
Demonstration video  
vídeo de demonstración  
vídeo de demostración



CÓDIGO /CODE / CODE / CÓDIGO	EMBALAGEM / QUANTITY / EMBALLAGE / EMBALAJE
004240000283	100

**Clamex P10**



**VIDEO DEMONSTRAÇÃO**  
Demonstration video  
vídeo de demonstración  
vídeo de demostración



CÓDIGO /CODE / CODE / CÓDIGO	EMBALAGEM / QUANTITY / EMBALLAGE / EMBALAJE
004240000227	100
004240000228	1000

**Divario P18**



**VIDEO DEMONSTRAÇÃO**  
Demonstration video  
vídeo de demonstración  
vídeo de demostración



CÓDIGO /CODE / CODE / CÓDIGO	EMBALAGEM / QUANTITY / EMBALLAGE / EMBALAJE
004240000244	100
004240000245	300
004240000246	1000

**Bisco P10/P15**



**VIDEO DEMONSTRAÇÃO**  
Demonstration video  
vídeo de demonstración  
vídeo de demostración



CÓDIGO /CODE / CODE / CÓDIGO	EMBALAGEM / QUANTITY / EMBALLAGE / EMBALAJE
004600000005	80

**Tenso P14**



**VIDEO DEMONSTRAÇÃO**  
Demonstration video  
vídeo de demonstración  
vídeo de demostración



CÓDIGO /CODE / CODE / CÓDIGO	EMBALAGEM / QUANTITY / EMBALLAGE / EMBALAJE
004240000237	100
004240000238	1000

**Clamex S**



**VIDEO DEMONSTRAÇÃO**  
Demonstration video  
vídeo de demonstración  
vídeo de demostración



CÓDIGO /CODE / CODE / CÓDIGO	EMBALAGEM / QUANTITY / EMBALLAGE / EMBALAJE
004240000200	100
004240000203	300



# FERRAGENS

Furniture Hardware / Quincaillerie du Meuble / Herrajes

## Lamello

Lamello / Lamello / Lamello



### CLASSIC X

### Fresadora Classic X

Milling Machine Classic X / Classic X Fraiseuse / Engalletadora Classic X



VIDEO DEMONSTRAÇÃO  
Demonstration video  
vídeo de demonstración  
video de demostración

780 W | 10.000 rpm



CÓDIGO /CODE / CODE / CÓDIGO	EMBALAGEM / QUANTITY / EMBALLAGE / EMBALAJE
004240000207	1



## SISTEMAS DE UNIÃO / Joint System / Système d'Assemblage / Sistema de Unión

### E20 H



VIDEO DEMONSTRAÇÃO  
Demonstration video  
vídeo de demonstración  
video de demostración



### E20 L



VIDEO DEMONSTRAÇÃO  
Demonstration video  
vídeo de demonstración  
video de demostración



### K20



### Lamello



VIDEO DEMONSTRAÇÃO  
Demonstration video  
vídeo de demonstración  
video de demostración



CÓDIGO /CODE / CODE / CÓDIGO	EMBALAGEM / QUANTITY / EMBALLAGE / EMBALAJE
004240000217	100

CÓDIGO /CODE / CODE / CÓDIGO	EMBALAGEM / QUANTITY / EMBALLAGE / EMBALAJE
004240000218	100

CÓDIGO /CODE / CODE / CÓDIGO	EMBALAGEM / QUANTITY / EMBALLAGE / EMBALAJE
004240000219	100

CÓDIGO /CODE / CODE / CÓDIGO	EMBALAGEM / QUANTITY / EMBALLAGE / EMBALAJE
T10 004600000001	1000
T20 004600000000	1000

## CABINEO

### Sistema de União Invisível para CNC's

Invisible Joint System for CNC machines / Système de Union Invisible pour CNC's / Sistema de Unión Invisible para CNCs

#### CABINEO 8mm



#### CABINEO 12mm

	CÓDIGO /CODE / CODE / CÓDIGO	EMBALAGEM / QUANTITY / EMBALLAGE / EMBALAJE
CABINEO 8mm	004240000218	100
	004240000218	300
	004240000218	1000
	004240000218	2000
CABINEO 12mm	004240000218	100
	004240000218	300
	004240000218	1000
	004240000218	2000



## MINIMAG

### Starterkit MINIMAG para INVIS

MINIMAG Starterkit for INVIS / INVIS Starterkit / INVIS Kit



VIDEO DEMONSTRAÇÃO  
Demonstration video  
vídeo de demonstración  
video de demostración

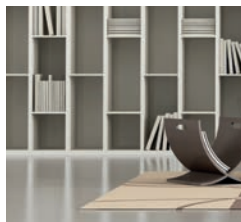

CÓDIGO /CODE / CODE / CÓDIGO	EMBALAGEM / QUANTITY / EMBALLAGE / EMBALAJE
004240000223	1

## MINIMAG



### INVIS Mx2 com porca

Mx2 connector set with stud / Mx2 avec  
boulon / Mx2 con tuerca

#### 14mm



250kg

### PORCA 14 mm

Stud 14 mm / Boulon 14 mm  
/ Tuerca 14 mm

#### 14mm



### INVIS Parede Central

Centre-wall stud / Boulon pour cloison  
/ Bulón

#### 10-30mm



CÓDIGO /CODE / CODE / CÓDIGO	EMBALAGEM / QUANTITY / EMBALLAGE / EMBALAJE
004240000210	20

CÓDIGO /CODE / CODE / CÓDIGO	EMBALAGEM / QUANTITY / EMBALLAGE / EMBALAJE
004240000222	30

CÓDIGO /CODE / CODE / CÓDIGO	EMBALAGEM / QUANTITY / EMBALLAGE / EMBALAJE
004240000220	10

CÓDIGO /CODE / CODE / CÓDIGO	EMBALAGEM / QUANTITY / EMBALLAGE / EMBALAJE
004240000211	1





## Roupeiros

Wardrobes / Penderies / Roperos

### 1 - Perfil puxador / Handle Profile / Profil de la poignée / Perfil de tirador



### 2 - Calha superior / Upper Rail / Rail supérieur / Canaleta superior



### 3 - Calha inferior / Lower Rail / Rail inférieur / Canaleta inferior

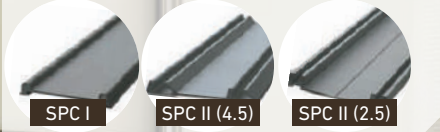

### 4 - Perfil U e H / U and H Profile / Profil U et H / Perfil U y H



### 5 - KIT rodízios / Rollers / KIT chariots / KIT rieles



### 6 - Puxador portas e gavetas / Handle for doors and drawers / Poignée pour portes et tiroirs / Tirador para puertas y cajones

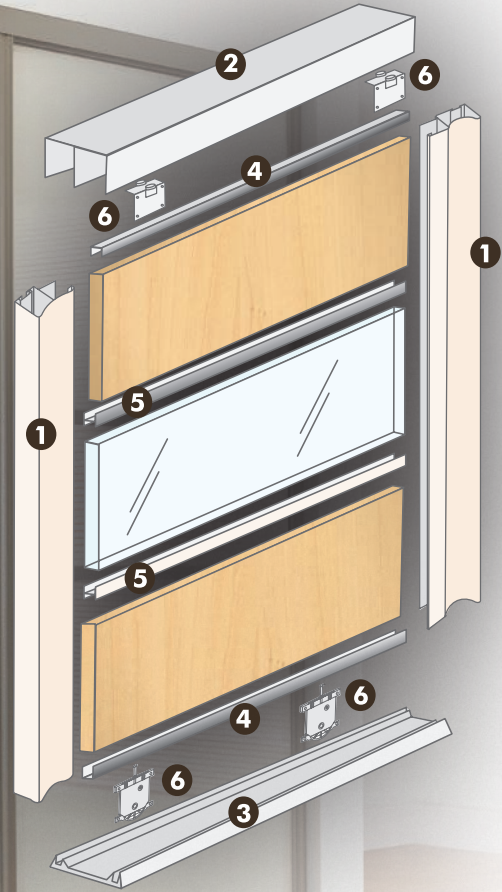

### FI09



460x335x85 mm

CÓDIGO / CODE / CODE / CÓDIGO	EMBALAGEM / QUANTITY / EMBALLAGE / EMBALAJE
004216100090	1

### FI20/21

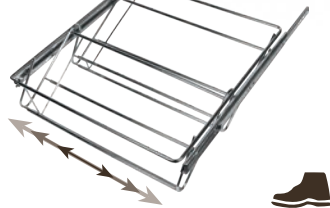

FI20 450x560-1000x110 | FI21 450x460-800x110 mm

CÓDIGO / CODE / CODE / CÓDIGO	EMBALAGEM / QUANTITY / EMBALLAGE / EMBALAJE
FI20 004217100200	1
FI21 004217100210	1

### Varão Roupeiro / Wardrobe Rod / Tringle de Penderie / Barra de Ropero



CÓDIGO / CODE / CODE / CÓDIGO	EMBALAGEM / QUANTITY / EMBALLAGE / EMBALAJE
VR02 004208000000	1
VR01 004207000000	1
VR03 004207500000	1
SV01 004209010000	30
SV02M 004209020000	20
SV02N 004209020001	20
SV03 004209030000	25
SV04 004209040000	20
SV05 004209010100	20

### SEPC10



CÓDIGO / CODE / CODE / CÓDIGO	EMBALAGEM / QUANTITY / EMBALLAGE / EMBALAJE
004290000001	1



# FERRAGENS

Furniture Hardware / Quincaillerie du Meuble / Herrajes

## Acessórios

Accessories / Accessoires / Accesorios

### COMPASSOS / Flap fitting / Compas / Compases

#### CP-04 Compasso a gás

/ Gas Compass / Compas à Gaz / Compás a Gas



CÓDIGO / CODE / CODE / CÓDIGO	EMBALAGEM / QUANTITY / EMBALLAGE / EMBALAJE
50N 004206040050	10
80N 004206040000	10
100N 004206040100	10
120N 004206040120	10
150N 004206040150	10

#### CP-05 p/porta rebatida

/ for Rebated Door / p/ Porte Rabattable / p/ Puerta Abatible



CÓDIGO / CODE / CODE / CÓDIGO	EMBALAGEM / QUANTITY / EMBALLAGE / EMBALAJE
E 004206050000	1

### BLE600

#### Balde Lixo Ecológico c/ soft-close

/ Ecologic Trash Bucket w/ soft-close / Poubelle Écologique avec amortisseur / Cubo de Basura Ecológico c/ amortiguador



CÓDIGO / CODE / CODE / CÓDIGO	EMBALAGEM / QUANTITY / EMBALLAGE / EMBALAJE
004300050200	1

### PUXADORES / Handles / Poignées / Tiradores

#### PX 48



CÓDIGO / CODE / CODE / CÓDIGO	EMBALAGEM / QUANTITY / EMBALLAGE / EMBALAJE
004248190250	25

#### PX 01 / 03 / 11 / 13

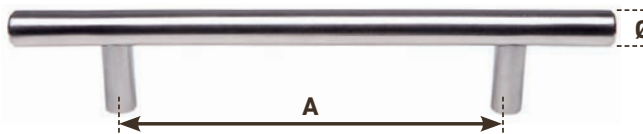

A	PX01	PX03	PX11	PX13	EMBALAGEM / QUANTITY / EMBALLAGE / EMBALAJE
	Ø12	Ø12	Ø10	Ø10	
96	004201120960	-	004201100960	004203100960	25
128	004201121280	004203121280	004201101280	004203101280	25
160	004201121600	004203121600	004201101600	004203101600	25
192	004201121920	004203121920	004201101920	004203101920	25
224	004201122240	004203122240	004201102240	004203102240	25
256	-	-	-	004203102560	25
320	004201123200	004203123200	004201103200	004203103200	25

#### PX 18

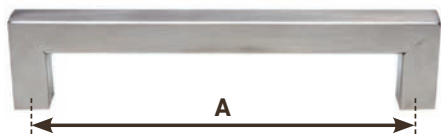

A	CÓDIGO / CODE / CODE / CÓDIGO	EMBALAGEM / QUANTITY / EMBALLAGE / EMBALAJE
96	004201800960	25
128	004201801280	25
160	004201801600	25
192	004201801920	25
242	004201802420	25
292	004201802920	25
342	004201803420	25
392	004201803920	25

#### PX 40

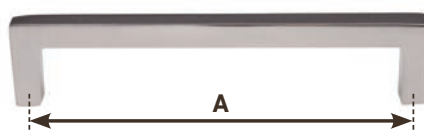

A	CÓDIGO / CODE / CODE / CÓDIGO	EMBALAGEM / QUANTITY / EMBALLAGE / EMBALAJE
96	004207000960	20
128	004207001280	25
160	004207001600	25
192	004207001920	25
224	004207002240	25
256	004207002560	25

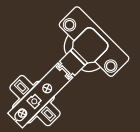

**Acessórios**

Accessories / Accessoires / Accesorios

**SISTEMAS DE UNIÃO / Joint System / Système d'Assemblage / Sistema de Unión**

**Cavilha**

/ Wooden Dowels / Tourillons / Tubillones

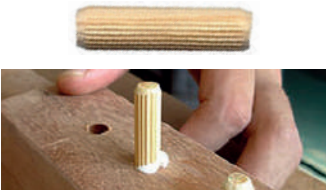

CÓDIGO	
/CODE / CODE / CÓDIGO	/ QUANTITY / EMBALLAGE / EMBALAJE
FAIA / BEECH / HÊTRE / HAYA	0047001...
PINHO / PINE / PIN / PINO	004701...

**SU-02L**



CÓDIGO		EMBALAGEM	
/CODE / CODE / CÓDIGO	/ QUANTITY / EMBALLAGE / EMBALAJE	/ QUANTITY / EMBALLAGE / EMBALAJE	/ QUANTITY / EMBALLAGE / EMBALAJE
PA	004240360100	50	
Zn	004240360101	50	

**SU-03 / 04**

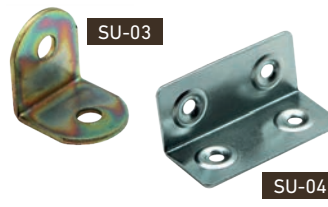

CÓDIGO		EMBALAGEM	
/CODE / CODE / CÓDIGO	/ QUANTITY / EMBALLAGE / EMBALAJE	/ QUANTITY / EMBALLAGE / EMBALAJE	/ QUANTITY / EMBALLAGE / EMBALAJE
SU-03	004240370000	200	
SU-04	004240380000	200	

**SU-06 ZN 45°**



CÓDIGO		EMBALAGEM	
/CODE / CODE / CÓDIGO	/ QUANTITY / EMBALLAGE / EMBALAJE	/ QUANTITY / EMBALLAGE / EMBALAJE	/ QUANTITY / EMBALLAGE / EMBALAJE
	004240600000	50	

**SUPORTES DE PRATELEIRAS**

/ Support Shelf / Supports d'Étagères / Soportes Estanterías

**SP 01**

CÓDIGO		EMBALAGEM	
/CODE / CODE / CÓDIGO	/ QUANTITY / EMBALLAGE / EMBALAJE	/ QUANTITY / EMBALLAGE / EMBALAJE	/ QUANTITY / EMBALLAGE / EMBALAJE
	066512050160	1000	



**A**

**SP 05 / 06 / 07**

CÓDIGO		EMBALAGEM	
/CODE / CODE / CÓDIGO	/ QUANTITY / EMBALLAGE / EMBALAJE	/ QUANTITY / EMBALLAGE / EMBALAJE	/ QUANTITY / EMBALLAGE / EMBALAJE
SP05	004204050000	500	
SP06	004204060000	500	
SP07	004204070000	500	



**PP**  
POLYPROPYLENE

**A**

**SP 04**

CÓDIGO		EMBALAGEM	
/CODE / CODE / CÓDIGO	/ QUANTITY / EMBALLAGE / EMBALAJE	/ QUANTITY / EMBALLAGE / EMBALAJE	/ QUANTITY / EMBALLAGE / EMBALAJE
SP04	004204040000	500	
SP04A	004204040001	1000	



**A**

**SP 03**

CÓDIGO		EMBALAGEM	
/CODE / CODE / CÓDIGO	/ QUANTITY / EMBALLAGE / EMBALAJE	/ QUANTITY / EMBALLAGE / EMBALAJE	/ QUANTITY / EMBALLAGE / EMBALAJE
	004204030000	500	



**A**

**SP 08**

CÓDIGO		EMBALAGEM	
/CODE / CODE / CÓDIGO	/ QUANTITY / EMBALLAGE / EMBALAJE	/ QUANTITY / EMBALLAGE / EMBALAJE	/ QUANTITY / EMBALLAGE / EMBALAJE
	004204080000	500	



**PP**  
POLYPROPYLENE

**Zk**  
ZAMAK

**SP 11**

CÓDIGO		EMBALAGEM	
/CODE / CODE / CÓDIGO	/ QUANTITY / EMBALLAGE / EMBALAJE	/ QUANTITY / EMBALLAGE / EMBALAJE	/ QUANTITY / EMBALLAGE / EMBALAJE
	004209050000	250	



**PP**  
POLYPROPYLENE

**Zk**  
ZAMAK

**PERFIL RODAPÉ COZINHA**

/ Baseboard Profile / Profil Plinthe Cuisine / Perfil Rodapié Cocina

**PRC1**

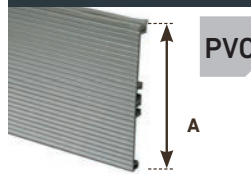

**PVC**

CÓDIGO		EMBALAGEM	
/CODE / CODE / CÓDIGO	A	/ QUANTITY / EMBALLAGE / EMBALAJE	/ QUANTITY / EMBALLAGE / EMBALAJE
	95	10	
	115	10	
	145	10	

**PRC3**

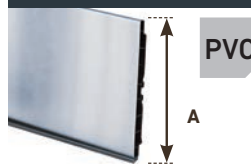

**PVC**

CÓDIGO		EMBALAGEM	
/CODE / CODE / CÓDIGO	A	/ QUANTITY / EMBALLAGE / EMBALAJE	/ QUANTITY / EMBALLAGE / EMBALAJE
	100	15	
	120	15	
	150	15	

**PRC4**

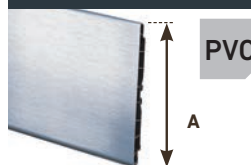

**PVC**

CÓDIGO		EMBALAGEM	
/CODE / CODE / CÓDIGO	A	/ QUANTITY / EMBALLAGE / EMBALAJE	/ QUANTITY / EMBALLAGE / EMBALAJE
	100	5	
	120	5	
	150	5	

**PRC6**

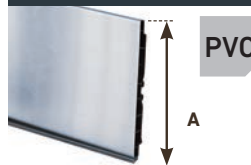

**PVC**

CÓDIGO		EMBALAGEM	
/CODE / CODE / CÓDIGO	A	/ QUANTITY / EMBALLAGE / EMBALAJE	/ QUANTITY / EMBALLAGE / EMBALAJE
	100	15	
	120	15	
	150	15	





# FERRAGENS

Furniture Hardware / Quincaillerie du Meuble / Herrajes

## Acessórios

Accessories / Accessoires / Accesorios

### Tampas Autocolantes (plástico ABC)

Cover Caps / Caches Autocollants (Plastique ABS) / Tapas Autopegables (Plástico ABS)



Ø20 mm

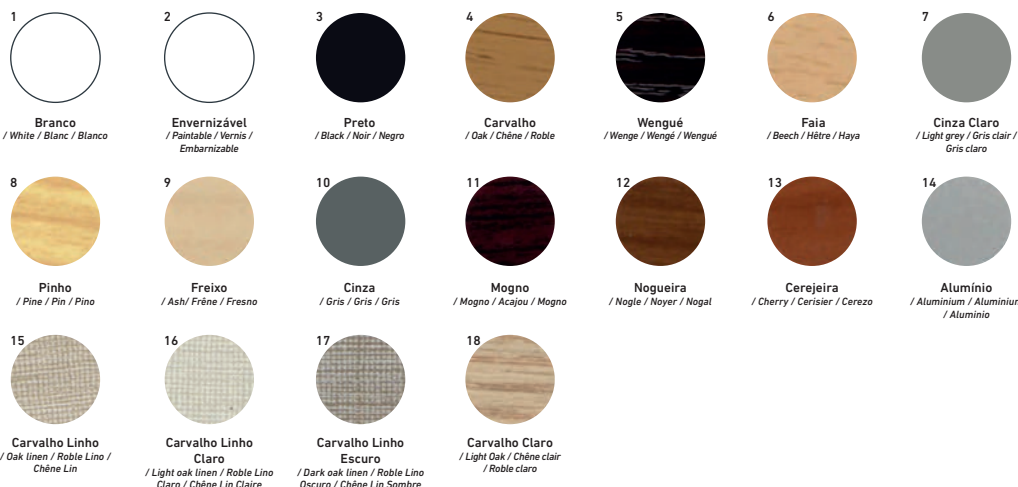

Ø13 mm



COR	Ø13	EMBALAGEM / QUANTITY / EMBALLAGE / EMBALAJE	Ø20	EMBALAGEM / QUANTITY / EMBALLAGE / EMBALAJE
1	050301000000	2000	050401000000	900
2	050301400000	2000	050401400000	900
3	050304000000	2000	050404000000	900
4	050305000000	2000	050405000000	900
5	050301300000	2000	050401300000	900
6	050309000000	2000	050409000000	900
7	050301200000	2000	050406000000	900
8	050307000000	2000	-	-
9	050301100000	2000	-	-
10	050303000000	2000	-	-
11	050308000000	2000	-	-
12	050306000000	2000	-	-
13	050302000000	2000	-	-
14	050301800000	2000	-	-
15	050301500000	2000	-	-
16	050301600000	2000	-	-
17	050301700000	2000	-	-
18	050301900000	2000	-	-

### PB10 | PB20

### Perfil de Borracha p/ Porta de Madeira

Rubber profile / Profil en Caoutchouc p/ Porte en Bois / Perfil de Goma p/ Puerta de Madera

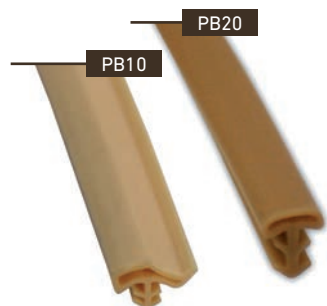

COR	PB10	EMBALAGEM / QUANTITY / EMBALLAGE / EMBALAJE	PB20	EMBALAGEM / QUANTITY / EMBALLAGE / EMBALAJE
4	004230101000	100 m	004230201000	100 m
5	004230104000	100 m	-	-
6	004230103000	100 m	004230203000	100 m
11	004230102000	100 m	004230202000	100 m

### BT10

### Batente Autocolante

Buffer Pads / Butée Autocollante / Batiente Autopegable



CÓDIGO / CODE / CODE / CÓDIGO	A	B	EMBALAGEM / QUANTITY / EMBALLAGE / EMBALAJE
004221007150	7	1.5	250
004221008160	8	1.6	250
004221010150	10	1.5	250
004221010300	10	3.0	250



# GESO CARTONADO

DRYWALL  
PLAQUES DE PLÂTRE  
YESO LAMINADO



# GESSO CARTONADO

Drywall / Plaques de Plâtre / Yeso Laminado

## PCL 750

### Bucha Metálica PCL 750

Steel Anchor For Thin Hollow Walls PCL 750 / Cheville Métallique PCL 750 / Taco Metálico PCL 750

PCL 750

Zincado / Zinc plated / Zingué / Zincado



CÓDIGO CODE / CODE / CÓDIGO	DIMENSÕES SIZE / DIMENSIONS / MEDIDA	ESPESSURA DO SUBSTRATO SUBSTRATE THICKNESS / ÉPAISSEUR DU SUPPORT / ESPESOR MATERIAL BASE	EMBALAGEM QUANTITY / EMBALLAGE / EMBALAJE
075023040380	M4 x 38 Ø8	3 - 11	250
075023040450	M4 x 45 Ø8	10 - 16	100
075023050450	M5 x 45 Ø11	8 - 13	100
075023050580	M5 x 58 Ø11	3 - 16	100
075023050710	M5 x 71 Ø11	19 - 32	100
075023060450	M6 x 45 Ø13	8 - 13	100
075023060580	M6 x 58 Ø13	3 - 16	100
075023060710	M6 x 71 Ø13	19 - 32	50



Quadros | Candeeiros | Rodapés | Aparelhos elétricos | Cortinas

Pictures | Lamps | Footer | Curtain rails | Electric Switchers

Cadres | Lampes | Plinthes | Appareils électriques | Rideaux

Cuadros | Lámparas | Rodapiés | Aparatos eléctricos | Cortinas

Alicate de rebitar buchas 750 / Installation plier / Pince à riveter cheville 750 / Alicata de remachar tacos 750



CÓDIGO CODE / CODE / CÓDIGO	EMBALAGEM QUANTITY / EMBALLAGE / EMBALAJE
049908040050	1

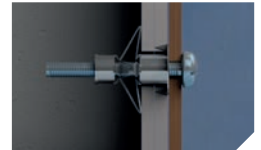
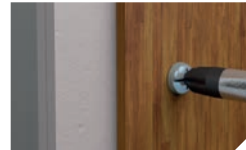
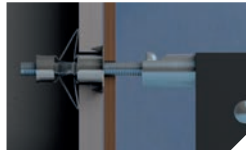

PCL 750

PCL 518

PCL 501

PCL 504

PCL 504

PCL 508



## TABELA COMPARATIVA DE CARGAS PARA FIXAÇÃO EM PLACA DE GESSO CARTONADO

Comparative table of loads for fixings in plate of laminated plaster / Tableau comparatif de charges pour fixations en plaque de plâtre laminé / Tabla comparativa de cargas para fijaciones en placa de yeso laminado



## Bucha para Gesso PCL 504

Self Drilling Dry Wall Plug PCL 504 / Cheville pour Plâtre PCL 504 / Taco para Yeso PCL 504

# PCL 504

Zamak / Zamak / Zamak / Zamak

PCL 504



CÓDIGO CODE / CODE / CÓDIGO	DIMENSÕES SIZE / DIMENSIONS / MEDIDA	ESPESSURA MIN. DO SUBSTRATO MIN. SUBSTRATE THICKNESS / MIN. ÉPAISSEUR DU SUPPORT / MIN. ESPESOR MATERIAL BASE	MEDIDA PARAFUSO SCREW SIZE / DIMENSION VIS / MEDIDA TORNILLO	EMBALAGEM QUANTITY / EMBALLAGE / EMBALAJE
050481060370	6 x 37	10	3.5 x 35	250



**Quadros | Fixação de interruptores | Candeeiros | Calhas técnicas | Rodapés**  
Pictures | Fixings switchers | Lamps | Cable ducts | Skirting boards  
Cadres | Fixation d'interrupteurs | Lampes | Goulottes techniques | Plinthes  
Cuadros | Fijación de interruptores | Lámparas | Canaletas técnicas | Rodapiés

Poliamida / Polyamide / Polyamide / Poliamida

PCL 504



CÓDIGO CODE / CODE / CÓDIGO	DIMENSÕES SIZE / DIMENSIONS / MEDIDA	ESPESSURA MIN. DO SUBSTRATO MIN. SUBSTRATE THICKNESS / MIN. ÉPAISSEUR DU SUPPORT / MIN. ESPESOR MATERIAL BASE	MEDIDA PARAFUSO SCREW SIZE / DIMENSION VIS / MEDIDA TORNILLO	EMBALAGEM QUANTITY / EMBALLAGE / EMBALAJE
050400060370	6 x 37	10	3.5 x 35	250



**Quadros | Fixação de interruptores | Candeeiros | Calhas técnicas | Rodapés**  
Pictures | Fixings switchers | Lamps | Cable ducts | Skirting boards  
Cadres | Fixation d'interrupteurs | Lampes | Goulottes techniques | Plinthes  
Cuadros | Fijación de interruptores | Lámparas | Canaletas técnicas | Rodapiés

## Bucha Poliamida PCL 508

Polyamide Toggle Anchor PCL 508 / Cheville en Polyamide PCL 508 / Bucha de Poliamida PCL 508

# PCL 508



CÓDIGO CODE / CODE / CÓDIGO	DIMENSÕES SIZE / DIMENSIONS / MEDIDA	ESPESSURA DO SUBSTRATO SUBSTRATE THICKNESS / ÉPAISSEUR DU SUPPORT / ESPESOR MATERIAL BASE	EMBALAGEM QUANTITY / EMBALLAGE / EMBALAJE
050400100380	10 X 38 Ø10	4-12	200
050400100470	10 X 47 Ø10	15-19	100

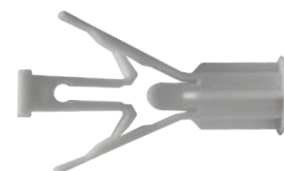

**Quadros Aparelhos elétricos | Calhas de cortinas | Candeeiros | Condutas de cabos | Rodapés**  
Pictures | Fixings switchers | Curtain rails | Lamps | Cable ducts | Skirting boards  
Cadres | Appareils électriques | Tringles à rideau | Lampes | Goulottes de câbles | Plinthes  
Cuadros | Aparatos eléctricos | Canaletas de cortinas | Lámparas | Conductos de cabos | Rodapiés

## Bucha Poliamida p/ Gesso PCL 623

Concrete Polyamide Nail-it Anchor PCL 623 / Cheville Polyamide p/ Plâtre PCL 623 / Taco Poliamida p/ Yeso PCL 623

# PCL 623



CÓDIGO CODE / CODE / CÓDIGO	DIMENSÕES SIZE / DIMENSIONS / MEDIDA	ESPESSURA A FIXAR FIXTURE THICKNESS / ÉPAISSEUR À FIXER / ESPESOR A FIJAR	EMBALAGEM QUANTITY / EMBALLAGE / EMBALAJE
062300060250	6 x 25	5	200
062300060380	6 x 38	9	250



CÓDIGO CODE / CODE / CÓDIGO	DIMENSÕES SIZE / DIMENSIONS / MEDIDA	ESPESSURA A FIXAR FIXTURE THICKNESS / ÉPAISSEUR À FIXER / ESPESOR A FIJAR	SACO BAG / SAC / BOLSA
062300060250	6 x 25	5	1000



**Rodapés**  
Base boards  
Plinthes  
Rodapiés



# GESSO CARTONADO

Drywall / Plaques de Plâtre / Yeso Laminado

## PCL 622

### Bucha TAP-TIP

Hammer in Polyamide Plug / Cheville à Frapper / Taco Clavable TAP-TIP

PCL 622.1

**Cabeça embeber e rosca arpão** / Countersunk head and harpoon thread / Tête fraisée et fil harpon / Cabeza avellanada y rosca arpão  
Zincado / Zinc plated / Zingué / Zincado

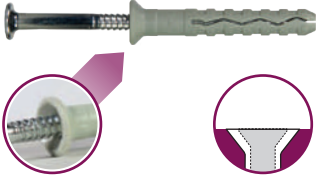
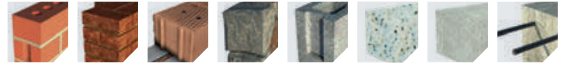

CÓDIGO CODE / CODE / CÓDIGO	DIMENSÕES SIZE / DIMENSIONS / MEDIDA	ESPESSURA A FIXAR FIXTURE THICKNESS / ÉPAISSEUR À FIXER / ESPESOR A FIJAR	EMBALAGEM QUANTITY / EMBALLAGE / EMBALAJE
062201060400	6 x 40 Ø6	10	200
062201060500	6 x 50 Ø6	20	200
062201060600	6 x 60 Ø6	30	200



Ligadores de parede | Rodapés | Componentes elétricos | Subestruturas | Prateleiras | Sinais | Louças sanitárias  
Wall connectors | Base boards | Electric components | Substructures | Shelves | Signs | Sanitary ware  
Prises de mur | Plinthes | Composants électrique | Substructure | Étagères | Signes | Articles sanitaires  
Conectores de pared | Rodapiés | Componentes eléctricos | Subestructuras | Estanterías | Rétulos | Sanitarios

## PCL 518

### Bucha Poliamida eXtreme One PCL 518

eXtreme One Polyamide Plug PCL 518 / Cheville en Polyamide eXtreme One PCL 518 / Taco de Poliamida eXtreme One PCL 518



CÓDIGO CODE / CODE / CÓDIGO	DIMENSÕES SIZE / DIMENSIONS / MEDIDA	DIÂMETRO ACONSELHADO RECOMMENDED DIAMETER / DIAMÈTRE RECOMMANDÉE / DIÁMETRO RECOMENDADO			EMBALAGEM QUANTITY / EMBALLAGE / EMBALAJE
		AGLOMERADO CHIPBOARD SCREW / VIS AGGLO / TORNILLOS AGLOMERADO	AUTO-ROSCANTES SELF TAPPING SCREWS / VIS À TÔLE / TORNILLOS AUTORROSCANTES	ROSCA MÉTRICA METRIC COARSE THREAD / FILETAGE MÉTRIQUE / ROSCA MÉTRICA	
051821060000	6 x 30	Ø4 - 5	Ø4 - 5	M4	500
051821060001	6 x 30	Ø4 - 5	Ø4 - 5	M4	200
051821080000	8 x 40	Ø4.5 - 6	Ø4.5 - 6	M5	200
051821080001	8 x 40	Ø4.5 - 6	Ø4.5 - 6	M5	100



Quadros | Candeeiros | Cortinados | Interruptores elétricos | Caixa Correio | Pequenas prateleiras de parede | Rodapés |  
Caixilharias de alumínio | Sanitários  
Frames | Lamps | Curtain rails | Electric switchers | Mailboxes | Small wall shelves | Base boards | Aluminum frames | Sanitary ware  
Cadres | Lampes | Rideaux | Interrupteurs électriques | Boîtes aux lettres | Petites étagères de mur | Plinthes | Cadres en aluminium | Articles sanitaires  
Cuadros | Lámparas | Cortinajes | Interruptores eléctricos | Buzones | Estanterías de pared | Zócalos | Marcos de aluminio | Sanitarios







## Bucha Latão

Brass Anchor / Cheville en Laiton / Taco de Latón

# PCL 700



CÓDIGO CODE / CODE / CÓDIGO	DIMENSÕES SIZE / DIMENSIONS / MEDIDA	COMPRIENTO LENGTH / LONGUEUR / LONGITUD	EMBALAGEM QUANTITY / EMBALLAGE / EMBALAJE
050051060000	M6 Ø8	23	200
050051080000	M8 Ø10	28	200

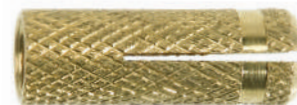

## Bucha com Olhal PCL 755

Ceiling wire hanger PCL 755 / Cheville à œillet PCL 755 / Taco con ojal

# PCL 755

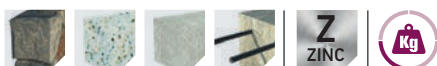

CÓDIGO CODE / CODE / CÓDIGO	DIMENSÕES SIZE / DIMENSIONS / MEDIDA	EMBALAGEM QUANTITY / EMBALLAGE / EMBALAJE
075523060600	6 x 60	100



Tetos falsos | Gradeamentos | Perfis | Escadas | Pilares de madeira  
Suspending drywall ceiling | Railing | Profiles | Stairs | Wood columns  
Faux-plafonds | Grillage | Profilés | Escaliers | Piliers en bois  
Falsos techos | Enrejados | Perfiles | Escaleras | Pilares de madera

## Mola Basculante PCL 762

Spring Toggles PCL 762 / Cheville à Ressort PCL 762 / Anclaje Palomilla PCL 762

# PCL 762

Cabeza de palomilla / Spring Toggle head / Tête segment à ressort / Mola basculante

PCL 762



CÓDIGO CODE / CODE / CÓDIGO	DIMENSÕES SIZE / DIMENSIONS / MEDIDA	EMBALAGEM QUANTITY / EMBALLAGE / EMBALAJE
076223040000	M4	100
076223050000	M5	100
076223060000	M6	100
076223080000	M8	100



Cortinas | Toalheiros | Candeeiros | Ventoinhas  
Curtain rails | Towel rails | Overhead lights | Ceiling fans  
Rideaux | Portes serviettes | Lampes | Ventilateurs  
Cortinas | Toalleros | Lámparas | Ventiladores

Tornillo / Screw / Vis / Parafuso

PCL 762



CÓDIGO CODE / CODE / CÓDIGO	DIMENSÕES SIZE / DIMENSIONS / MEDIDA	EMBALAGEM QUANTITY / EMBALLAGE / EMBALAJE
076223040701	M4 x 70	50



Cortinas | Toalheiros | Candeeiros | Ventoinhas  
Curtain rails | Towel rails | Overhead lights | Ceiling fans  
Rideaux | Portes serviettes | Lampes | Ventilateurs  
Cortinas | Toalleros | Lámparas | Ventiladores

Gancho / Hook / Crochet / Camarão

PCL 762



CÓDIGO CODE / CODE / CÓDIGO	DIMENSÕES SIZE / DIMENSIONS / MEDIDA	EMBALAGEM QUANTITY / EMBALLAGE / EMBALAJE
076223040700	M4 x 70	50



Cortinas | Toalheiros | Candeeiros | Ventoinhas  
Curtain rails | Towel rails | Overhead lights | Ceiling fans  
Rideaux | Portes serviettes | Lampes | Ventilateurs  
Cortinas | Toalleros | Lámparas | Ventiladores



# GESSO CARTONADO

Drywall / Plaques de Plâtre / Yeso Laminado

PCL 762

Pitão / Eye bolt / Piton / Argolla



CÓDIGO CODE / CODE / CÓDIGO	DIMENSÕES SIZE / DIMENSIONS / MEDIDA	EMBALAGEM QUANTITY / EMBALLAGE / EMBALAGEM
076223040702	M4 x 70	50



**Cortinas | Toalheiros | Candeiros | Ventoinhas**  
 Curtain rails | Towel rails | Overhead lights | Ceiling fans  
 Rideaux | Portes serviettes | Lampes | Ventilateurs  
 Cortinas | Toalleros | Lámparas | Ventiladores

# PCL 203

## Parafuso cabeça de embeber phillips fosfatado

Drywall screw for plasterboard, with bugle head, twinfast thread / Vis pour plaques de plâtre, tête trompette, double filet / Tornillo para placas de yeso laminado con cabeza trompeta, rosca doble hilo

PCL 203

Fosfatado / Black-phosphated / Phosphaté / Fosfatado



CÓDIGO CODE / CODE / CÓDIGO	DIMENSÕES SIZE / DIMENSIONS / MEDIDA		CAPACIDADE DE PERFURAÇÃO DRILL CAPACITY / CAPACITÉ DE PERÇADE / CAPACIDAD DE TALADRADO	EMBALAGEM QUANTITY / EMBALLAGE / EMBALAGEM
020321350190	3,5 x 19	PH2	0,8	1000
020321350250	3,5 x 25	PH2	0,8	1000
020321350320	3,5 x 32	PH2	0,8	1000
020321350350	3,5 x 35	PH2	0,8	1000
020321350450	3,5 x 45	PH2	0,8	500
020321350550	3,5 x 55	PH2	0,8	500
020321390250	3,9 x 25	PH2	0,8	1000
020321390350	3,9 x 35	PH2	0,8	500
020321390450	3,9 x 45	PH2	0,8	500
020321390550	3,9 x 55	PH2	0,8	500



CÓDIGO CODE / CODE / CÓDIGO	DIMENSÕES SIZE / DIMENSIONS / MEDIDA		CAPACIDADE DE PERFURAÇÃO DRILL CAPACITY / CAPACITÉ DE PERÇADE / CAPACIDAD DE TALADRADO	EMBALAGEM QUANTITY / EMBALLAGE / EMBALAGEM
020321350251	3,5 x 25	PH2	0,8 - 3	1000
020321350351	3,5 x 35	PH2	0,8 - 3	1000
020321350451	3,5 x 45	PH2	0,8 - 3	500

# DIN 7504-N

## Parafuso Autoperfurante Cabeça de Queijo, Philips

Self-drilling screw with panhead, Phillips recess / Vis autoperceuse, pointe foreuse, tête cylindrique bombée, Phillips / Tornillo autotaladrante de cabeza alomada y huella Phillips

DIN 7504-N

Zincado / Zinc plated / Zingué / Zincado



CÓDIGO CODE / CODE / CÓDIGO	DIMENSÕES SIZE / DIMENSIONS / MEDIDA		ESP. MÁX A FIXAR MAX FIXTURE THICKNESS / ÉPAISSEUR MAX À FIXER / ESP. MÁX A FIJAR	CAPACIDADE DE PERFURAÇÃO DRILL CAPACITY / CAPACITÉ DE PERÇADE / CAPACIDAD DE TALADRADO	EMBALAGEM QUANTITY / EMBALLAGE / EMBALAGEM
981022060100	3,5 x 9,5	PH2	3,85	2,25	1000

# DIN 6334

## Porca de Ligação

Coupling nut / Écrou hexagonal haut / Tuerca hexagonal de prolongación

DIN 6334

Zincado / Zinc plated / Zingué / Zincado



CÓDIGO CODE / CODE / CÓDIGO	DIMENSÕES SIZE / DIMENSIONS / MEDIDA	EMBALAGEM QUANTITY / EMBALLAGE / EMBALAGEM
633412060180	M6 x 18	250
633412080240	M8 x 24	250



## Porca sextavada de rosca métrica

Hexagon nuts metric thread / Écrou hexagonal à filetage métrique / Tuerca hexagonal rosca métrica

# DIN 934

Zincado / Zingué / Zinc Plated / Zincado

DIN 934

**Z**  
ZINC

CÓDIGO CODE / CODE / CÓDIGO	DIMENSÕES SIZE / DIMENSIONS / MEDIDA	EMBALAGEM QUANTITY / EMBALLAGE / EMBALAGEM
093422060000	M6	1000
093422080000	M8	500



## Haste rosçada

Threaded rod / Tige filetée / Varilla rosçada

# DIN 975

Zincado / Zingué / Zinc Plated / Zincado

DIN 975

**Z**  
ZINC

CÓDIGO CODE / CODE / CÓDIGO	DIMENSÕES SIZE / DIMENSIONS / MEDIDA	EMBALAGEM QUANTITY / EMBALLAGE / EMBALAGEM
097512061000	Ø6 x 1 mt	1
097512062000	Ø6 x 2 mt	1
097512081000	Ø8 x 1 mt	1
097512082000	Ø8 x 2 mt	1



## Abraçadeira curva em L com porca M6

Fixing Clamp with M6 Nut - L / Collier - L Écrou hexagonal M6 / Abrazadera Curva - L con Tuerca M6

**Z**  
ZINC

CÓDIGO CODE / CODE / CÓDIGO	EMBALAGEM QUANTITY / EMBALLAGE / EMBALAGEM
000012605601	100



## Abraçadeira curva em U com porca M6

Fixing Clamp with M6 Nut - U / Collier - U Écrou hexagonal M6 / Abrazadera Curva - U con Tuerca M6

**Z**  
ZINC

CÓDIGO CODE / CODE / CÓDIGO	EMBALAGEM QUANTITY / EMBALLAGE / EMBALAGEM
000012605602	100





# GESSO CARTONADO

Drywall / Plaques de Plâtre / Yeso Laminado

## Corrediza M6 com furo

Slide M6 with hole / Slide M6 avec trou / Slide M6 con agujero

Zincado / Zinc plated / Zingué / Zincado



**CÓDIGO**  
CODE / CODE / CÓDIGO  
000012207002

**EMBALAGEM**  
QUANTITY / EMBALLAGE / EMBALAGEM  
1000

## Emenda para perfil

Amendment to profile / Amendement ou profil / Enmienda para perfil

Zincado / Zinc plated / Zingué / Zincado

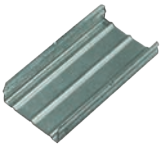

**CÓDIGO**  
CODE / CODE / CÓDIGO  
000912200201

**EMBALAGEM**  
QUANTITY / EMBALLAGE / EMBALAGEM  
100

## Pivot para perfil

Pivot for profile / Pivot pour le profil / Pivote para perfil

Zincado / Zinc plated / Zingué / Zincado



**CÓDIGO**  
CODE / CODE / CÓDIGO  
000912200101

**EMBALAGEM**  
QUANTITY / EMBALLAGE / EMBALAGEM  
50

## Espátulas de Construção

Construction Spatulas / Spatules de Construction / Espátulas de Construcción

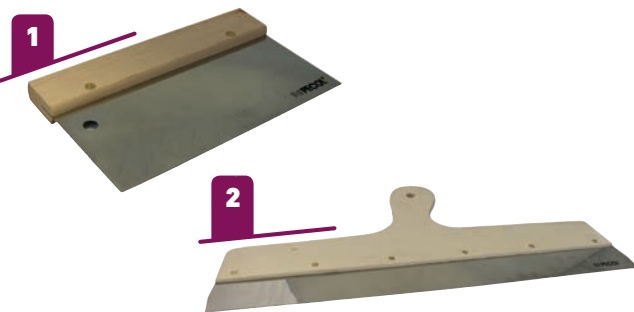

**CÓDIGO**  
CODE / CODE / CÓDIGO

**DIMENSÕES**  
SIZE / DIMENSIONS / MEDIDA

**EMBALAGEM**  
QUANTITY / EMBALLAGE / EMBALAJE

<b>1</b>	<b>Espátula reta</b> / Smooth Spatula / Spatule droite / Espátula recta	000886704020	200	12
<b>2</b>	<b>Espátula para gesso</b> / Spatula for Plaster / Spatule pour plâtre / Espátula para yeso	000886704022	500	12



Aplicação de colas, adesivos, gesso e gesso cartonado | Construção em geral  
Application of glues, adhesive, plaster and plasterboard joints | Construction in General  
Application de colles, adhésifs, plâtre et plâtre cartonné | Construction en générale  
Aplicación de pegamentos, adhesivos, yeso y yeso acartonado | Construcción en general

## Espátula de Borracha / Rubber Spatula / Spatule en Caoutchouc / Espátula de Goma



<b>CÓDIGO</b> CODE / CODE / CÓDIGO	<b>TAMANHO</b> SIZE / TAILLE / TAMAÑO	<b>EMBALAGEM</b> QUANTITY / EMBALLAGE / EMBALAJE
000886704035	300	12



Utilizável para preenchimento de juntas  
Used for filling joints  
Utilisable pour remplissage de joints  
Utilizable para relleno de juntas

## Espátula Flexível / Flexible Spatula / Spatule Flexible / Espátula Flexible



<b>CÓDIGO</b> CODE / CODE / CÓDIGO	<b>TAMANHO</b> SIZE / TAILLE / TAMAÑO	<b>EMBALAGEM</b> QUANTITY / EMBALLAGE / EMBALAJE
000886704027	25	12
000886704028	38	12
000886704029	50	12
000886704030	60	12
000886704031	75	12
000886704032	100	12
000886704033	120	12
000886704034	150	12



Ideal para aplicação de gesso, cola e massa  
Ideal for applying plaster, glues and putties  
Idéale pour application de plâtre, colle et pâtes  
Ideal para aplicación de yeso, pegamento y masilla

## Rolo de fita perfurada **PCL 3018**

Steel fixing band / Rouleau de Bande Perforée / Rollo Cinta Perforada

Galvanizado / Galvanisé / Galvanized / Galvanizado



CÓDIGO CODE / CODE / CÓDIGO	DIMENSÕES SIZE / DIMENSIONS / MEDIDA	COMPRIENTO LENGTH / LONGUEUR / LONGITUD	EMBALAGEM QUANTITY / EMBALLAGE / EMBALLAGEM
301812120080	12 x 0,8	10mt	10
301812170080	17 x 0,8	10mt	10

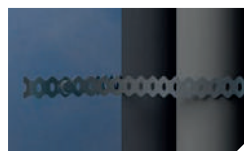
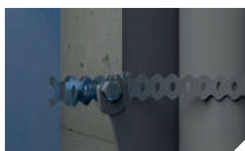
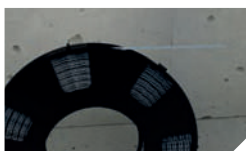

## Discos Corte Fino Premium - AÇO INOX

Flat Cutting Thin Wheels Premium - STAINLESS STEEL / Meules à Tronçonner fines Premium - ACIER INOX / Discos Corte Fino Premium - ACERO INOX

CÓDIGO CODE / CODE / CÓDIGO	DIMENSÕES SIZE / DIMENSIONS / MEDIDA	EMBALAGEM QUANTITY / EMBALLAGE / EMBALAGEM	QTD. PALETE PALET / QT. PALETTE / CANT. PALÉ
007200021150	115 x 1.0 x 22.23	50	8000
007200021250	125 x 1.0 x 22.23	50	8000
007200021800	180 x 1.6 x 22.23	25	3000
007200022300	230 x 2.0 x 22.23	25	3000



## Selante Acrílico

Acrylic Sealant / Mastic Acrylique / Sellante Acrílico



CÓDIGO CODE / CODE / CÓDIGO	COR** COLOR / COULEUR / COLOR	CAPACIDADE CAPACITY / CAPACITÉ / CAPACIDAD	EMBALAGEM QUANTITY / EMBALLAGE / EMBALLAGEM	QTD. PALETE PALET / QT. PALETTE / CANT. PALÉ	
002701000000	Branco / white / Blanc / Blanco	9003	310 ml	25	900
002702000000	Cinza / Grey / Gris / Gris	7004	310 ml	25	900

\*\* Cor do produto aproximada à cor RAL / The color of the product is close to color RAL / Couleur du produit similaire à couleur RAL / Color del producto aproximada al color RAL



## Arame

Wire / Fil / Alambre



CÓDIGO CODE / CODE / CÓDIGO	DIMENSÕES SIZE / DIMENSIONS / MEDIDA	EMBALAGEM QUANTITY / EMBALLAGE / EMBALAGEM
001918406211	2,11 (N.º 14)	25Kg
001918406241	2,41 (N.º 13)	25Kg
001918406277	2,77 (N.º 12)	25Kg
001918406304	3,04 (N.º 10)	25Kg
001918406305	3,05 (N.º 11)	25Kg





# GESSO CARTONADO

Drywall / Plaques de Plâtre / Yeso Laminado

## Fitas

Tapes / Ruban / Cintas

### Fita para fissuras / Fiber glass mesh / Bande à fissures / Cinta para fissuras



**CÓDIGO**  
CODE / CODE / CÓDIGO

**DIMENSÕES**  
SIZE / DIMENSIONS / MEDIDA

**DENSIDADE**  
DENSITY / DENSITÉ / DENSIDAD

**EMBALAGEM**  
QUANTITY / EMBALLAGE /  
EMBALLAGE

001909489065

48 x 90mt

65gr/m<sup>2</sup>

12

### Banda para gesso cartonado / Drywall joint paper tape / Ruban de papier / Cinta de papel

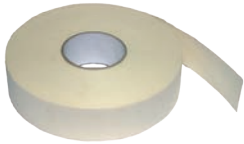

**CÓDIGO**  
CODE / CODE / CÓDIGO

**DIMENSÕES**  
SIZE / DIMENSIONS / MEDIDA

**DENSIDADE**  
DENSITY / DENSITÉ / DENSIDAD

**EMBALAGEM**  
QUANTITY / EMBALLAGE /  
EMBALLAGE

001903050150

50 x 150mt

140gr/m<sup>2</sup>

10

### Fita reforçada para cantos / Metal corner drywall tape / Bandes de coins / Cinta de esquinas y rincones



**CÓDIGO**  
CODE / CODE / CÓDIGO

**DIMENSÕES**  
SIZE / DIMENSIONS / MEDIDA

**DENSIDADE**  
DENSITY / DENSITÉ / DENSIDAD

**EMBALAGEM**  
QUANTITY / EMBALLAGE /  
EMBALLAGE

001907050000

50 x 30mt

140gr/m<sup>2</sup>

10





**CONDIÇÕES DE  
VENDA**

# CONDIÇÕES GERAIS DE VENDA E PRESTAÇÃO DE SERVIÇOS PARA PORTUGAL CONTINENTAL

## 1. Objeto e Vigência

- 1.1. As Condições Gerais de Venda e Prestação de Serviços (as "Condições Gerais") regulam as transações comerciais entre a PECOL – Sistemas de Fixação, S.A. ("PECOL") e o Cliente, em que a primeira vende e o segundo compra materiais fabricados ou comercializados pela PECOL.
- 1.2. As presentes Condições Gerais entram vigor na data de assinatura da Ficha de Abertura de Cliente/Crédito, e prevalecem sobre quaisquer condições gerais do Cliente, salvo acordo escrito em contrário e que revogam as anteriormente em vigor.

## 2. Preço

- 2.1. Os preços das mercadorias a adquirir pelo Cliente são os que se encontram em vigor à data da encomenda, constantes do sistema informático ou tabelas de preços da PECOL, denominados em Euros, sendo-lhes acrescidos IVA à taxa legal em vigor e custos de transporte aplicáveis à data de encomenda.
- 2.2. Os preços constantes da tabela de preços da PECOL estão sujeitos a alterações sem aviso prévio.
- 2.3. Os eventuais descontos a conceder sobre os preços definidos na tabela de preços, baseiam-se exclusivamente em critérios comerciais e são da inteira responsabilidade da PECOL.

## 3. Abertura de Conta a Crédito

- 3.1. O Cliente poderá abrir uma linha de crédito junto da PECOL tendo em vista a aquisição de mercadorias nos termos das presentes Condições Gerais.
- 3.2. A abertura de conta a crédito está sujeita a aprovação prévia dos serviços financeiros da PECOL sendo para isso necessário o preenchimento do impresso Ficha de Abertura de Cliente/Crédito.
- 3.3. Quaisquer condições de pagamento que venham a ser concedidas poderão ser modificadas ou anuladas, caso a PECOL assim o entender.
- 3.4. Os fornecimentos a crédito só se aplicam para valores de faturas superiores a 50€.
- 3.5. Sem prejuízo do disposto nos números anteriores, a PECOL reserva-se no direito de não efetuar a abertura de conta a crédito, sem que para isso tenha de apresentar qualquer justificação.

## 4. Pagamento

- 4.1. O Cliente que não beneficie de Abertura de Conta a Crédito nos termos da Cláusula 3 deve, salvo acordo escrito em contrário, terá de efetuar o pagamento no ato de entrega dos materiais adquiridos.
- 4.2. Os pagamentos poderão ser realizados pelo Cliente em dinheiro, cartão de débito eletrónico (se disponível nas instalações da PECOL), por cheque até EUR 150,00, cheque visado acima deste valor ou ainda por transferência bancária.
- 4.3. O prazo do pagamento para o Cliente que beneficie da Abertura de Conta de Crédito nos termos da Cláusula 3 é de 30 (trinta) dias a partir da data da fatura, salvo acordo escrito em contrário e assinado por quem vincule ambas as partes e sempre após validação pelos serviços financeiros da PECOL.
- 4.4. O pagamento de faturas antes de decorridos 8 (oito) dias após a sua emissão será beneficiado com um desconto financeiro de 2%.
- 4.5. O não cumprimento dos prazos acordados implica a suspensão dos fornecimentos a crédito até à integral regularização dos débitos existentes, reservando-se a PECOL no direito de debitar juros de mora à taxa legal.
- 4.6. A PECOL pode suspender o fornecimento a crédito se o plafond de crédito atribuído ao cliente vier a ser ultrapassado ou por outra razão que vier a ser considerada como pertinente pelo serviços financeiros da PECOL.

## 5. Transporte e entregas

- 5.1. As mercadorias são despachadas por conta do Cliente, que suportará o risco pelo perecimento das mesmas ocorrido durante o transporte.
- 5.2. O transporte é escolhido pela PECOL que não será responsável por quaisquer danos sofridos pelas mercadorias a partir do momento em que as mesmas saem das suas instalações, incluindo, sem limitar, por danos sofridos durante o transporte.
- 5.3. A PECOL não é responsável por eventuais atrasos na entrega das mercadorias.

## 6. Receção das mercadorias

- 6.1. O Cliente deve conferir a quantidade de volumes de mercadoria recebidos e assinar a respetiva guia de transporte, confirmando a sua receção, sendo responsável pela verificação da conformidade das mercadorias em momento prévio à sua aceitação.
- 6.2. O Cliente deverá assegurar que a assinatura da guia de transporte é realizada por um responsável com poderes para o ato, não podendo apresentar qualquer reclamação nos termos da Cláusula 7 caso a guia de transporte não seja assinada por pessoa com poderes bastantes para receber a mercadoria.
- 6.3. A assinatura da guia de transporte pelo Cliente ou por pessoa designada pelo Cliente pressupõe que as mesmas estão em boas condições e em conformidade com a encomenda, não podendo o Cliente apresentar qualquer reclamação e solicitar a devolução do preço pago, nos termos da Cláusula 7.



## **7. Reclamações e devoluções**

7.1. O Cliente tem direito à devolução caso as mercadorias adquiridas no âmbito das presentes Condições Gerais sejam defeituosas, não sendo contudo aceites devoluções relativamente a produtos entregues em perfeitas condições e cujo fornecimento tenha sido realizado em conformidade com a encomenda do Cliente. Para os efeitos das presentes Condições Gerais, entende-se por mercadoria defeituosa aquela que não oferece ao Cliente a segurança com que legitimamente se pode contar, tendo em atenção todas as circunstâncias, designadamente a sua apresentação, a utilização que dele razoavelmente possa ser feita e o momento da sua entrada em circulação.

7.2. A devolução pelo Cliente depende da prévia apresentação de uma reclamação, por escrito, devidamente fundamentada e acompanhada de cópia da fatura referente às mercadorias defeituosas ou menção do respetivo número, enviada por correio registado com aviso de receção para a morada da PECOL, constante da Cláusula 14.3 no prazo de 8 (oito) dias úteis a contar da data de receção das mercadorias, sendo que a PECOL se reserva o direito de analisar a causa que originou o defeito do produto e desenvolver as medidas reputadas necessárias.

## **8. Certificados de qualidade e relatórios de conformidade**

8.1. A PECOL pode, caso o Cliente o solicite no momento da confirmação da encomenda, emitir certificados de qualidade e/ou relatórios de conformidade.

8.2. A PECOL poderá debitar ao Cliente os custos decorrentes da elaboração e emissão dos certificados de qualidade ou relatórios de conformidade, informando-o antecipadamente do valor em questão, se o valor faturado da mercadoria encomendada não for suficiente para absorver o custo do certificado.

## **9. Reserva de Propriedade**

9.1. Os materiais fornecidos ao Cliente manter-se-ão como sendo propriedade da PECOL até ao pagamento integral do mesmo, ficando o cliente investido da responsabilidade de fiel depositário do material, até ao total cumprimento da obrigação que assumiu.

## **10. Responsabilidade**

10.1. Os produtos fabricados pela PECOL são produzidos com o melhor material do tipo exigido, sendo desenvolvidos e fabricados atendendo à mais recente tecnologia aplicável ao setor.

10.2. A PECOL não é responsável por quaisquer danos sofridos pelo Cliente ou por terceiros, decorrentes da utilização das mercadorias adquiridas pelo Cliente nos termos das presentes Condições Gerais, salvo em caso de dolo ou culpa grave.

10.3. Todas as instruções, informações e recomendações associadas aos produtos fornecidos constantes nas embalagens, catálogos e fichas técnicas, correspondem ao melhor do conhecimento e experiência da PECOL e devem ser rigorosamente atendidas pelo Cliente no momento da utilização das mercadorias adquiridas.

10.4. Ao utilizar as mercadorias fornecidas, o Cliente deve assegurar-se antecipadamente que as mesmas são apropriadas para a utilização em causa.

10.5. Todos os dados e especificações, assim como as recomendações apresentadas pela PECOL estão sustentadas por numerosos estudos laboratoriais e validadas pela longa experiência da PECOL.

10.6. Tendo em consideração a grande variedade de materiais existentes no mercado, assim como as técnicas de aplicação do produto, que não poderão ser controladas pela PECOL, é recomendável que o Cliente proceda à execução de testes prévios com os materiais a usar recorrendo à respetiva técnica.

10.7. Para efeitos do número anterior, qualquer aplicação do produto é efetuada sob a exclusiva responsabilidade do Cliente, não podendo a PECOL ser responsabilizada por quaisquer perdas ou prejuízos, diretos ou indiretos resultantes da aplicação.

10.8. Em qualquer caso, a responsabilidade da PECOL por quaisquer danos sofridos pelo Cliente, decorrentes da utilização das mercadorias adquiridas, encontra-se limitada ao montante correspondente ao valor da encomenda do Cliente relativa a essas mercadorias.

10.9. O Cliente será sempre plenamente responsável por quaisquer consequências que possam advir do uso e da aplicação do produto.

## **11. Dados Pessoais**

11.1. A PECOL é a entidade responsável pelo tratamento dos dados pessoais. Ao assinar as presentes Condições Gerais está a autorizar a PECOL, nos termos da Lei 67/98, de 26 de Outubro, a efetuar o tratamento automatizado e informatizado dos dados de natureza pessoal por si facultados, inserindo-os nos seus ficheiros automáticos no âmbito da gestão de clientes.

11.2. O Cliente tem acesso aos respetivos dados pessoais, podendo solicitar a sua atualização, retificação e eliminação, mediante o respetivo pedido, por escrito, para a sede da PECOL, garantindo a veracidade e exatidão da informação de carácter pessoal facultada a esta entidade.

## **12. Foro**

12.1. Toda e qualquer questão emergente das presentes Condições Gerais, nomeadamente quanto à sua interpretação, validade, eficácia ou execução, é regida e regulada pelo Direito Português.

12.2. Para a resolução de qualquer litígio resultante das presentes Condições Gerais a PECOL e o Cliente elegem, com expressa renúncia a qualquer outro, o Tribunal da Comarca do Baixo Vouga.

## **13. Norma Geral**

13.1. A emissão e correspondente receção deste documento são prova suficiente de que o Cliente aceitou as condições de venda e prestação de serviços.

13.2. A PECOL reserva-se o direito de alterar as presentes Condições Gerais.

## 14. Domicílio e Comunicações

14.1. Para os efeitos do disposto no artigo 236.º do Código de Processo Civil, o domicílio ou sede do cliente será o que consta na Ficha de Abertura de Cliente, impresso nº Dq.121.1 Ficha de Abertura de Cliente/ Crédito e que será colocado em todas as faturas referentes às transações comerciais que venham a ser realizadas entre a PECOL e o Cliente.

14.2. Qualquer alteração de domicílio só será judicialmente oponível à PECOL caso seja comunicado, por carta registada com aviso de receção, no prazo de 30 (trinta) dias a contar do momento de alteração da morada.

14.3. Qualquer comunicação escrita dirigida à PECOL deve ser enviada por correio registado com aviso de recebimento, para a seguinte morada:

**PECOL – Sistemas de Fixação, S.A.**  
Apartado 3156 - Raso de Paredes  
3754 – 901, Águeda - **Portugal**  
**Tel.: +351 234 612 900**  
**www.pecol.pt**

**ESPAÑA / Spain / Espagne / España**  
**PECOL – Fijaciones S.L.**  
Polígono Cova Solera – Avda. Cova Solera s/n  
08191 Rubí, Barcelona  
Espanha  
Teléfono: +34 935884268  
www.pecolfijaciones.es

**MARROCOS / Morocco / Maroc / Marruecos**  
20, Rue Ibnou El Koutia  
Quartier Ind. Oukacha  
20500 – Casablanca  
MAROC  
Tel.: +212 0522246635  
Fax: +212 0522246637  
www.pecol.ma

**ITÁLIA / Italy / Italie / Italia**  
Via Europa 34/36  
20083 Vigano di Gaggiano MI  
ITALIA  
Tel.: +39 029086776 | Fax: +39 0290843181  
www.pecolitalia.com

### Tudo o que precisar de saber sobre informações técnicas As suas dúvidas serão respondidas com rapidez e competência

What you need to know about technical information  
Individual questions are answered quickly and competently

Tout ce que vous devez savoir sur informations techniques  
Nous répondrons rapidement et avec compétence à vos questions

Todo lo que necesita saber acerca de informaciones técnicas  
Sus preguntas serán contestadas de forma rápida y competente



#### Sede / headquarters / Siège social / Sede

 PORTUGAL  
+351 234 612 900



 geral@pecol.pt

#### FILIAL / Own stores / Succursale / Filiales



##### ESPAÑA / Spain / Espagne / España

 +34 935884268  
 pecol@pecolfijaciones.es

##### MARROCOS / Morocco / Maroc / Marruecos



 +212 0522246635  
 general@pecol.ma

##### ITÁLIA / Italy / Italie / Italia

 +39 029086776  
 info@pecolitalia.com

#### DEPARTAMENTO DE EXPORTAÇÃO

/ Export Department / Département export / Departamento de exportación

 +351 234 612 904  
 export@pecol.pt





**PORTUGAL** / Portugal / Portugal / Portugal

**PECOL** – Sistemas de Fixação, S.A.  
Apartado 3156 - Raso de Paredes  
3754 – 901, Águeda - PORTUGAL

Tel.: +351 234 612 900

Fax: +351 234 612 901

[www.pecol.pt](http://www.pecol.pt)

**ITÁLIA**

/ Italy / Italie / Italia

Via Europa 34/36

20083 Vigano di Gaggiano MI

ITALIA

Tel.: +39 029086776 | Fax: +39 0290843181

[www.pecolitalia.com](http://www.pecolitalia.com)

**MARROCOS**

/ Morocco / Maroc / Marruecos

PECOL – Fixations Maroc

20, Rue Ibnou El Koutia

Quartier Ind. Oukacha

20500 – Casablanca

Tel.: +212 0673120131 | Fax: +212 0522246637

[www.pecol.ma](http://www.pecol.ma)

**ESPAÑA**

/ Spain / Espagne / España

PECOL – Fijaciones S.L.

Polígono Cova Solera – Avda. Cova Solera s/n

08191 Rubí, Barcelona - España

Teléfono: +34 935884268

[www.pecolfijaciones.es](http://www.pecolfijaciones.es)

**DISTRIBUIDOR**

Retailer

Distributeur

Revendedor

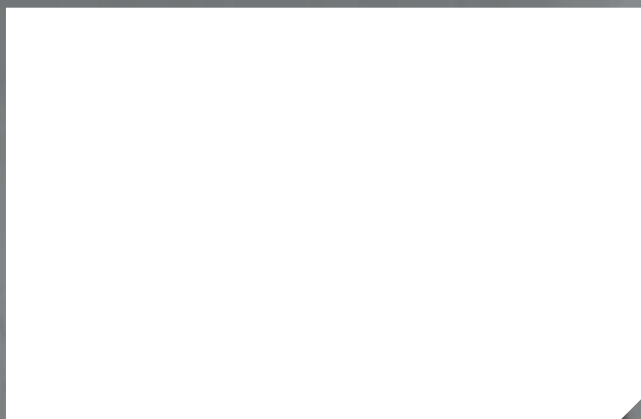

**O SEU FORNECEDOR DE SEMPRE,  
ONDE ESTIVER!**

/ Your ever-ready supplier, wherever you are! / Votre fournisseur de  
toujours, où que vous soyez! / Su proveedor de siempre, donde esté!

[HTTP://STORE.PECOL.PT/](http://HTTP://STORE.PECOL.PT/)

